



MANUAL FOR 8141

Installation/Operation/Warranty Guide

Effective September 2024

EQ026



(800) 846-9659
EQSystems.us

Manual For 8141
Installation/Operation/Warranty Guide
Effective September 2024

Contents

<u>Required Tools & Parts</u>	Page 3
<u>Foot Installation For SL Jack Leg Assemblies</u>	Page 4
<u>Pump/Fittings/Hoses</u>	Page 5
<u>Hose Connections</u>	Page 6
<u>Wire Harness</u>	Page 7
<u>Wiring</u>	Pages 8 - 9
<u>Purging & Manual Override</u>	Page 10
<u>Torque Specifications</u>	Pages 11 - 12
<u>Warranty</u>	Page 13

REQUIRED TOOLS AND PARTS

Tools Required for Installation

- Ratchet, sockets and wrench set
- Wire cutters/crimpers
- Electric drill/screw gun and bits
- Welding equipment (if welding leg or bracket in place)

Additional Items Required for Installation

- Fasteners for mounting jacks to frame, minimum 1/2" diameter grade 5
- # 4 AWG power wire ******(to connect battery +12V positive to the pump) *****
- # 4 AWG ground wire ******(to connect battery -12V ground to pump) *****
- # 4 AWG ring terminals ******
- Circuit breaker 100 amp manual reset type. For additional information please see page 9.
- Loom clips (to secure harness and hydraulic hoses to the coach)
- Self-drilling screws or pop rivets or other to secure harness and hoses.
- Wire ties
- 3.5 quarts Automatic Transmission Fluid (Dexron or multi-purpose ATF)

***Note:** These items must be # 2 AWG or larger if cable run is greater than 12 ft

**Note: Modification of any factory supplied item may result in the denial of all warranty claims.
Call EQ Systems Technical Support prior to any modifications.**

With any hydraulic application, holding position on a cylinder must be done with safety in mind. Failure in the system may cause the jacks to retract or extend suddenly. When working under or near the coach, always use jack stands of appropriate rating to support the weight of the coach.

JACKS

- The jacks will have to be bolted to the brackets using 1/2" diameter fasteners, min. grade 5.
- The jacks must have a minimum of 6 inches from the ground with the foot pads no lower than anything on the coach. Retract the jack fully, and determine the ground clearance by measuring to the bottom of the jack foot.

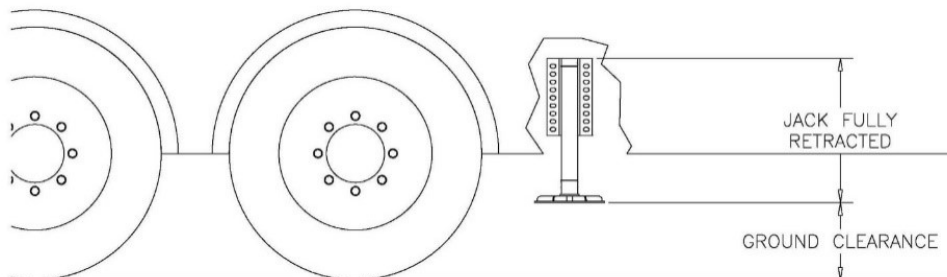

SL 11 Leg Assembly

This assembly uses the 3/4"-16 nylock jam nut.

Required for installation:

- 1/2" drive Impact wrench/gun
- 1/2" drive X 1 1/16" socket (6 point preferred)

Process

1. Check/verify that the threads on the end of the cylinder rod are clean and not damaged. Use the nylock nut to check that it will thread (start) on the end of the rod. Do not fully install or tighten at this time. Remove the nut.
2. Position the hole in the middle of the foot pad over the threaded end of the rod. Start the nylock nut onto the threads by hand.
3. Using the impact wrench/gun and the 1 1/16" socket, tighten the nut onto the rod. Note that the rod may rotate as you are doing this. Tighten the nut until between 1 and 3 threads are visible past the end of the nylock nut.

Notes

When properly installed, if the cylinder is extended slightly, the foot should pivot slightly and will be free to rotate.

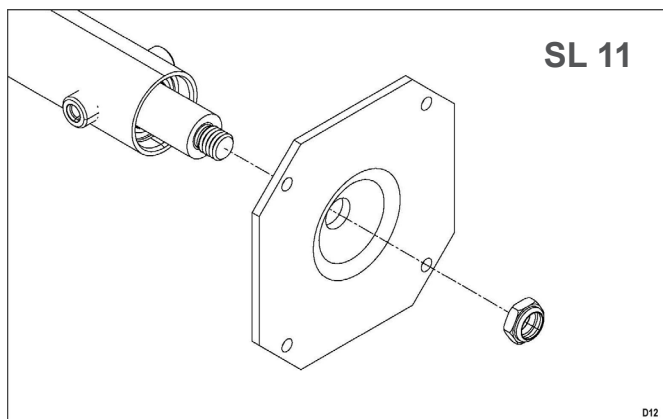

PUMP

Use the 3/8-16 threaded holes in the base of the pump assembly for mounting.

When installing the pump on the coach the location should provide access to:

- Route the hydraulic hoses to the manifold.
 - Fill the reservoir and monitor the fill level.
 - The cartridge valves and the end of the motor in case manual override of the system is required.
-

FITTINGS

Install the hydraulic adaptor fittings in the top and bottom of each jack and install the fittings into the manifold.

- The straight thread O-ring side always goes to the cylinder or manifold.
 - The tapered side will get the hose attached to it.
 - When installing straight fittings into the leg or manifold, tighten to 15 lbs-ft. When using 90-degree fittings, turn until finger tight, position correctly, then tighten the jam nut to 15 lbs-ft.
-

HOSE

Install the hydraulic hoses according to the chart.

- Route the hoses clear of all hot exhaust components and pinch points in the suspension/chassis system. (moving objects, sharp edges and high heat sources)
- Attach the hoses to the manifold and jack fittings.
- Tighten to 15 lbs-ft. Secure the hydraulic hoses with wire ties or loom clamps to the chassis.
- Care should be taken to not kink or twist hoses.
- The min. bend radius is 6 inches.

Installation of Hoses to the Manifold

Jack Leg

Left - Top
Left - Bottom

Right - Top
Right - Bottom

Manifold Connection

Brown Solid (T-1)
Brown Stripe (B-1)

White Solid (T-2)
White Stripe (B-2)

HOSE CONNECTIONS

RETRACT HOSE CONNECTIONS:
BOTTOM OF CYLINDERS
(BROWN STRIPE & WHITE STRIPE)

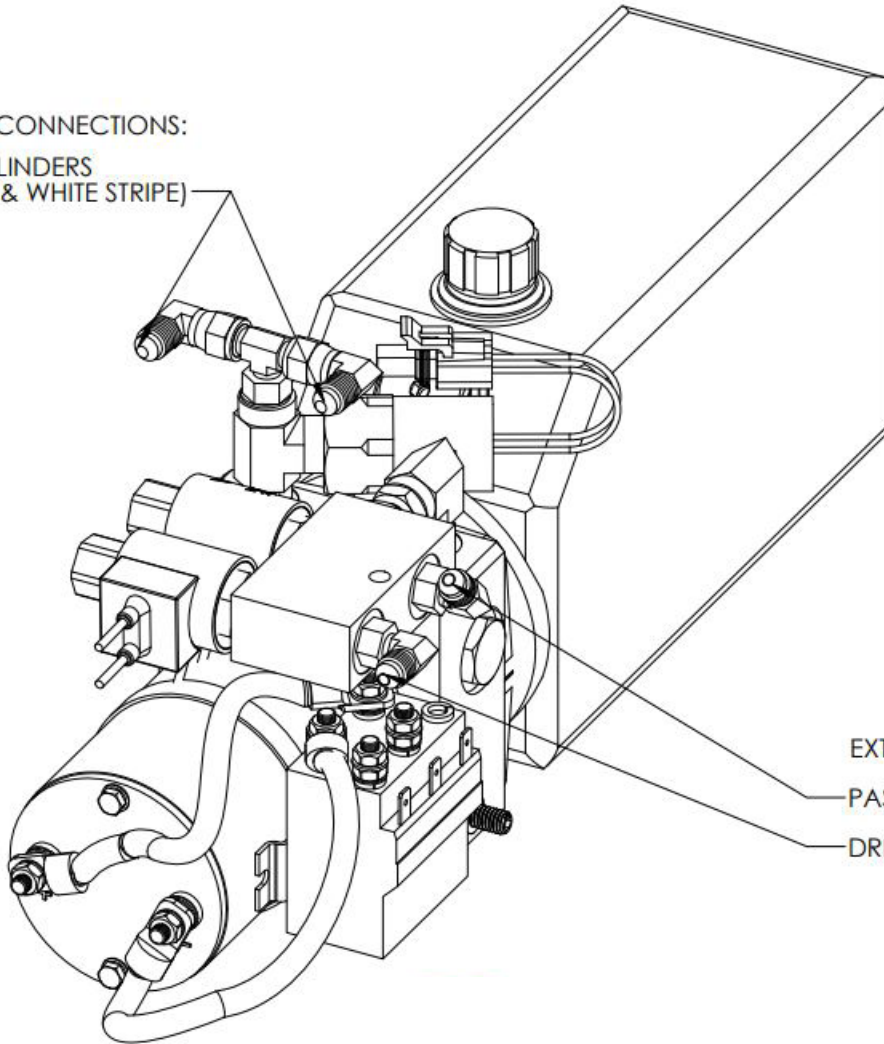

EXTEND HOSE CONNECTIONS:
PASSENGER SIDE TOP (WHITE)
DRIVER'S SIDE TOP (BROWN)

WIRE HARNESS

The wire harness will be left terminated at the pump. The connection and controls will be installed by Pebble Life.

There is one 6 position MAT-N-LOK housing that will be used to control all pump function. The pin out is as follows:

Pin 1 - Red/blue = Power

Pin 2 - Green = Signal to run pump in “reverse”, Retracts Jacks back up

Pin 3 - Blue = Signal to run pump “forward”, Runs jacks to the ground

Pin 4 - Brown = Signal to coil for left jack

Pin 5 - White = Signal to coil for right jack

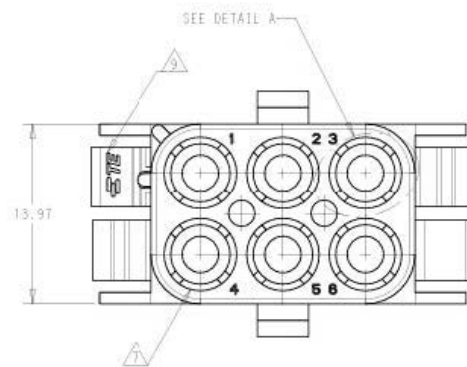

There is also a 2 way Weather-Pack terminating the pressure switch for the pump. Pebble Life will connect to this to read when pressure is built up or lost on the retract side of the jacks. The pin out is not crucial as this is read as an open or closed switch.

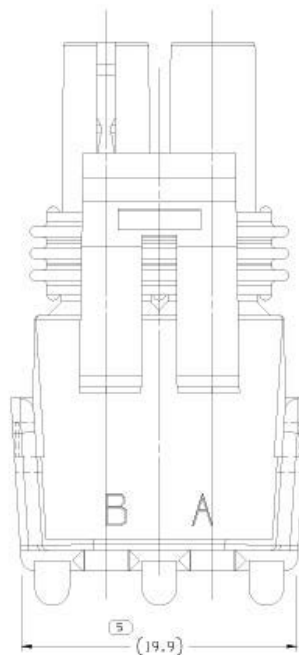

WIRING

Power Connection for Bi-Rotational Motor Pump #3432KS

Attach a # 4 gauge wire (# 2 gauge if the run is over 12ft.) between the **positive** +12v terminal on the battery and the stud "A" on the motor contactor as shown below in the wiring schematic.

- This battery connection may be fused at the source with a 100 amp circuit breaker.
- This +12v supply must be a dedicated and isolated circuit (not shared with other devices).

Attach a # 4 gauge wire (# 2 gauge if the run is over 12ft.) between the **negative** -12v terminal on the battery and the ground stud on the pump.

- This is the preferred method of grounding. If grounding the pump to the chassis, the connection must be sound, free of paint and not susceptible to corrosion.
- The battery connection to the frame must also be # 4 gauge or larger cable.

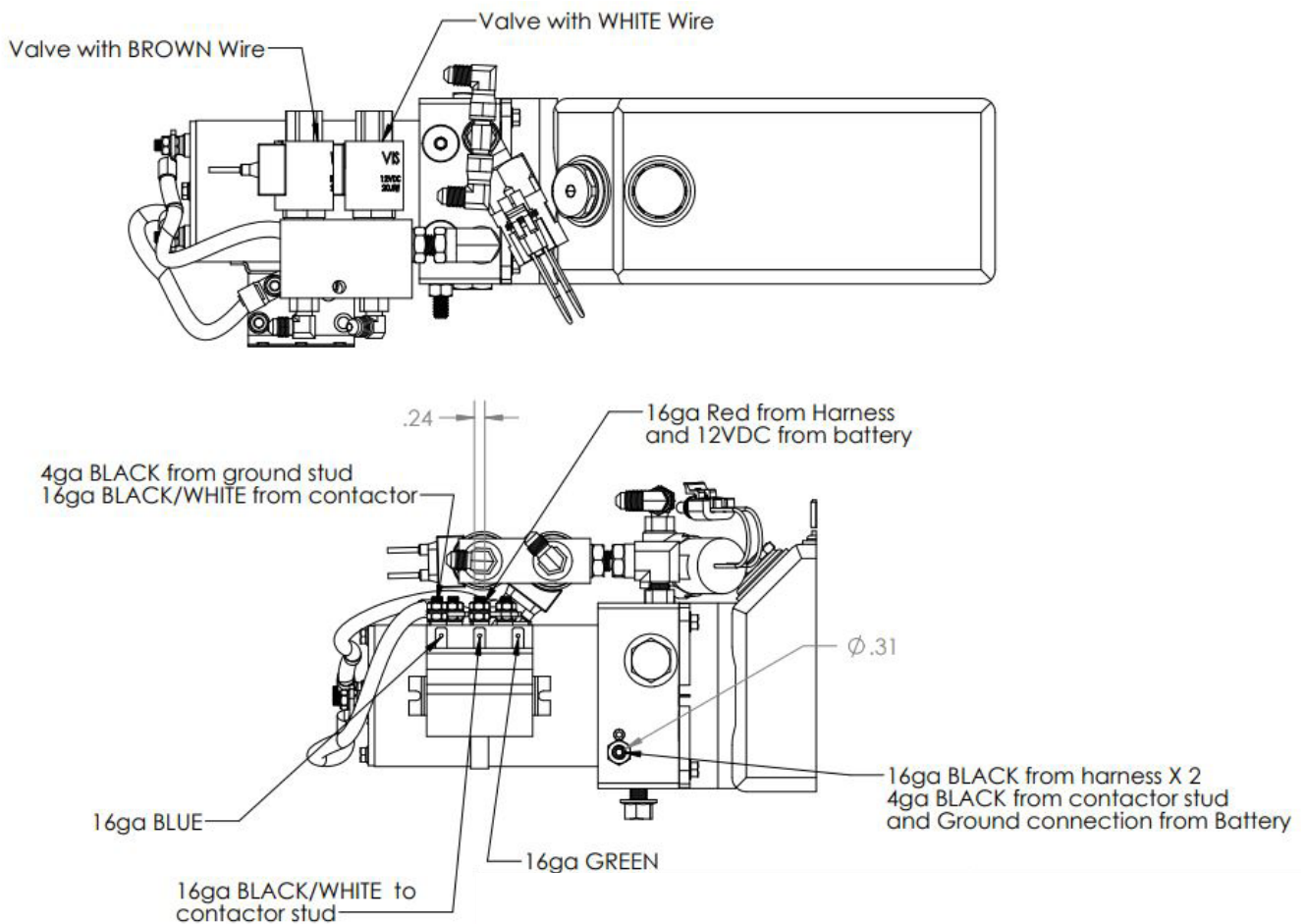

Note: All wire gauge sizes and breaker ratings noted are the recommended size. Larger gauge wiring and higher breaker rating may be used. There may be variances on specific systems supplied to OEM customers due to the exact makeup of the system.

Additional information on Power Supply connections

The below is just general information to be used as a guide.

Battery Size Considerations

Generally, the greater the size of the battery or bank the better. A group 24 RV deep cycle marine battery should be considered the minimum.

Multiple batteries connected in parallel is common. The battery or bank should have some sort of charging system in place to keep the battery or bank at peak charge for proper operation.

Circuit Breakers

The breaker should be of the manual reset type that is typical of the RV/Marine industries usage. This should be of the “slow blow or trip type” to avoid nuisance tripping due to current surges common to the hydraulic pump motor start up. These surges may be many times the normal pump amperage generally lasting only milliseconds.

Note: if a fuse is used in lieu of a breaker, a “slow blow” type of higher amperage rating is recommended to prevent nuisance “blowing” of the fuse.

The purpose of the breaker is to provide protection against shorting to ground of the positive feed to the pump assembly. It is not needed for system overload protection which is provided by the hydraulic systems relief circuit.

Battery Type and Size

A minimum group 24 RV/marine type battery is recommended. Battery rating should be a minimum 100 RC (Reserve capacity) with a 500 CCA (Cold Cranking Amperage). The higher these numbers the better. Common types are flooded lead acid, Gel and AGM (Absorbed Glass Mat).

Note: Some lithium batteries are not suited for this application. As they cannot provide the high running amperage and surges. Check with the battery supplier/manufacture for info on this.

Additional Notes on Wiring

There may be additional wiring at the pump or near the control panel for specific OEM requirements. Check with EQ Systems on the usage of these if present.

Purging Bi-Rotational Pump # 3432KS

You must follow this procedure strictly. Any deviation from the process will cause the purging process to become difficult and time consuming.

1. Fill pump reservoir to full approx. 1 to 1 ½ inch from top with automatic transmission fluid, the multipurpose or any of the Dexron/Mercon fluids will work.
2. Using the manual switch for the jacks extend the jacks until they make ground contact. Do not lift the vehicle. If the vehicle is on a lift the jacks may be fully extended.
3. Press all retract switch. After the jacks have fully retracted and the pump shuts off check the reservoir fluid. Refill to full approx. 1 to 1 ½ inch from top.
4. If the fluid in the reservoir is aerated or foamed up, allow time for foam/air to dissipate before continuing. Allow 10 minutes for foam and air to dissipate.
5. Fully extend the jacks. At this point they would be allowed to lift the vehicle. Allow 10 minutes for foam and air to dissipate.
6. Fully retract the jacks. Allow 10 minutes for foam and air to dissipate. Refill fluid to full, approximately 1 to 1 ½ inch from top.
7. Repeat steps 5 and 6.

Manual Override for Bi-Rotational Pump # 3432KS

Your hydraulic pump is equipped with a bi-rotational motor.

- You will use a 2000 r.p.m. drill and a 1/4" Allen Driver.
- Care must be taken to ensure neither the drill nor the socket contact any wires or hydraulic hoses while in use.

To Operate Your Jack(s) Using the Manual Override (with Bi-Rotational Motor)

- The individual cartridge valves are clustered together on the side of the pump manifold. Locate the screws on the appropriate cartridge valve(s). Using a 1/8" Allen wrench, turn the screw(s) clockwise until seated in.
- The motor has a foil sticker on the end, remove this sticker.
- Place the drill with the 1/4" Allen bit on the manual override shaft located at the end of the motor.
- To retract your jack(s) run the drill in the counter-clockwise direction. To extend your jack(s), run the drill in the clockwise direction.



(800) 846-9659

EQ SYSTEMS TORQUE SPECIFICATIONS

July 2024

The following list are items that the installer would encounter during the normal installation. The values listed are for EQ supplied fasteners and components. For other fasteners not listed follow EQ Systems specific installation manual instructions and or fastener industry/supplier specifications for fastener size, thread and grade. Generally, EQ systems use GR 5 specifications.

Adaptor Fittings At Manifold And Jack Cylinders

See installation instructions for proper installation/tightening of 90-degree fittings.

15-18 LB. FT.

Hose Fittings To Adaptor Fittings At Manifold And Cylinders

12 – 15 LB. FT.

Jack Cylinder To Bracket

75 LB. FT.

Pump Mount Stud/Bolt 3/8-16 Stud With Hex Nut (9/16-inch wrench)

20 LB. FT.

Electrical Connections

Motor Solenoid (contactor, reversing polarity type) Wire Terminals/Battery Positive Connection 6 MM Brass Stud (10 MM wrench)

32 to 34 LB. IN.

Pump Ground Stud 5/16-18 Stud With Hex Nut (1/2-inch wrench)

15-18 LB. FT.

Pump/Manifold Replacement Parts

Manifold To Lower Assembly Studs/Nuts 5/16-18 (1/2-inch wrench/socket)

12 to 20 LB. FT.

Manifold Adaptor Fittings And Plugs, Including Purge Coupler Nipples

15-18 lb. FT.

Pressure Switch

12 - 15 LB. Ft.

Manifold Valve

12 - 15 LB. FT.

Manifold Valve Coil Nut

4-6 LB. FT.

Reservoir Screws 5 mm (8 mm wrench)

4.5 LB. FT.

ELECTRICAL

Motor Solenoid/Contactors #2994

Motor Solenoid (contactor, reversing polarity type) Wire Terminals/Battery Positive And Ground Connection And Contactor To Motor Lead Studs

6 MM Brass Stud (10 MM wrench)

32 to 34 LB. IN.

Motor Attachment Screws 5 mm (8 mm wrench)

4.5 LB. FT.

Motor Terminal Stud/Nut (10 MM wrench)

32 -34 LB. IN.



MOTORHOME & FIFTH WHEEL WARRANTY

EQ Systems (Equalizer Systems) Limited Warranty Policy

May 2022

1. EQ Systems (Equalizer Systems) warrants slide out and leveling system components for a period of **one year** from the date of original sale of the vehicle. This warranty covers defects in material and workmanship only. EQ Systems (Equalizer Systems) is not liable for any damage due to abuse, neglect, misuse, negligence, misapplication, error of operation, accidental or purposeful damage or damage due to an "act of God" such as, wind or rain damage, flood, lightning, or other natural occurrence of the like. EQ Systems (Equalizer Systems) limited warranty is applicable to the EQ Systems (Equalizer Systems) components only and does not apply to the vehicle, apparatus, or property to which it is attached. Warranty parts will be shipped at no charge if the repair is authorized by an EQ Systems (Equalizer Systems) representative. Purchased components used in authorized warranty repairs will be reimbursed at the original purchase price.
2. Labor and freight expenses due to warrantable parts defects or workmanship will be reimbursed for a period of **one year** from the date of original sale of the vehicle. Freight expenses will either be prepaid by EQ Systems (Equalizer Systems) or reimbursed at the UPS Ground rate only. Any additional shipping charges or requirements are the obligation of the vehicle owner or service center performing the warranty repair. The owner or service center's obligation may include overseas shipping charges, border fees, brokerage fees and any other additional fee of the like.
3. Warranty labor will be reimbursed only for claims that have prior written or verbal authorization from an EQ Systems (Equalizer Systems) representative. Warranty labor compensation is required to correspond with the "OEM Warranty & Procedure Manual" published by EQ Systems (Equalizer Systems). Any warranty repair not listed on this guideline will require prior authorization from an EQ Systems (Equalizer Systems) representative. A reasonable time allowance will be determined by the EQ Systems (Equalizer Systems) representative. Any warranty repair that is not listed on this guideline that is performed without prior authorization will be denied without exception. Time associated with learning about the repair or excessive diagnostic and installation time will not be reimbursed. Warranty labor will be reimbursed at the authorized service center's published shop rate if the rate is reasonable for that region. Overtime labor will not be reimbursed without exception.
4. Labor, parts, and freight credit (if applicable) will be sent when the parts are tested, and the warranty claim is validated. Returned parts that are found to be in normal operating condition are not warrantable and will be charged to the owner or service center. EQ Systems (Equalizer Systems) reserves the right to charge back the service center for labor claim payments previously submitted if the installation of the warranted part is found to be inadequate at a later date.
5. Claims will be denied if the date submitted is greater than 120 days from the repair date.
6. Prior authorization is required before parts may be sent back to EQ Systems (Equalizer Systems). A Return Authorization Number is required for items to be accepted.
7. Complete systems are not warranted unless authorized by an EQ Systems (Equalizer Systems) representative. There are absolutely no exceptions to this clause.
8. Warranty coverage for parts or systems sold by non-authorized resellers (such as live or internet auctions) will be at the discretion of EQ Systems (Equalizer Systems).
9. EQ Systems (Equalizer Systems) is not liable for loss of time, manufacturing costs, labor, material, loss of profits, direct or indirect damages incurred by the vehicle manufacturer.
10. Excessive warranty labor resulting from inadequate access to the EQ Systems (Equalizer Systems) product will not be reimbursed.
11. EQ Systems (Equalizer Systems) will not pay a markup on warranty parts unless required by law.
12. Travel expenses, hotel, telephone, fuel, or any other expenses of the like are not covered under warranty.

Replacement Parts:

1. Replacement parts are warranted under the same guidelines listed above for the remainder of the original warranty or 90 days, whichever is longer. Proof of warranty repair date and original vehicle purchase date are required. No additional warranties, expressed or implied, are authorized by EQ Systems (Equalizer Systems)

This warranty voids all previous issues.

Questions concerning this warranty should be directed to:

EQ Systems (Equalizer Systems) | 19300 Grange Street, Cassopolis, MI, 49031

574-264-3437 | (800) 846-9659

To activate your warranty, please visit our website at www.eqsystems.us/activate-warranty/