



# **SOONER DUAL LEG HYDRAULIC TRAILER JACKS**

## **Installation/Operation/Warranty Guide**

Effective January 2014

EQ007R6



(800) 846-9659  
EQSystems.us

# SOONER HYDRAULIC TRAILER JACK

**Dual Leg Trailer Jack: 24,000 lb. - Stroke 20-24 in.**

## INSTALLATION

### **Tools Required for Installation:**

- Ratchet, sockets and wrench set
- Wire cutters/crimpers
- Electric drill an & bits
- Screw gun & bits
- Welding equipment (if welding in place)

### **Additional Parts Needed:**

- #4 gauge wire (to connect battery to pump positive and negative)
- #4 gauge ring terminals and heat shrink
- Bolts, nuts and washers (1/2 inch dia.) for jack mounting
- Loom clips (to secure switch and harness to the trailer)
- Self-tapping screws or pop rivets (to secure loom clips)
- Wire ties
- Automatic transmission fluid (Dexron) up to 12 quarts depending on the jack size



## JACKS

Jacks may have been provided with an upper and lower mounting channel that the inside will fit over a 4 inch wide channel. There are holes in the mounting channel to allow the use of bolts to pass thru the channel. When bolting the jacks to the trailer we recommend using grade 8 bolts of the proper size (1/2 inch) to “fill” the holes. Flat washers and locking style nuts are recommended. Basically the jack should be mounted adequately to lift the trailer and the tow vehicle as the coupler could “stick”. The jacks should be mounted so that when the trailer is level (while mounted to the tow vehicle) there is a minimum of 10 inches of ground clearance. This is usually achieved by mounting the jack so that the foot is slightly below the bottom edge of the trailer. The bottom of the footpad should not be lower than any other item on the trailer.

## PUMP MOUNTING

The base of the pump is drilled and tapped 3/8-16 to be used for mounting. Most are shipped with mounting fasteners for this purpose. Pumps may be mounted vertical or horizontal. They must be mounted so that the fill or breather cap is “UP” and in a position where it can be filled. There are 2 locations where the filler (breather cap) may be located depending on the mounting selected. When mounting vertically the motor must be “UP” or above the reservoir. If mounting horizontal the mounting holes/surface must face down. The pump assembly should be mounted in a manner that allows access for maintenance and to be able to perform “manual override” in the event that it is needed. See the section(s) on manual override for info on this. Also on units that have the selector valves, the valves will need to be accessible for the customer to operate. The pump assembly should be mounted in a box or compartment or a cover should be used to protect the unit from direct road spray and debris. One favored mounting location is on the front of a jack, many of the leg assemblies have a bracket for this purpose.

## SWITCH AND HARNESS

The switch box is made with a mounting plate with 4 holes (one in each corner) for mounting purposes. It may be mounted using screws or rivets. The type of screw or rivet is dependent on the type of surface that the switch box is too be mounted to. The screw head should be of a type that properly mates with the plastic surface. When selecting a mounting area be aware of the length and the routing of the harness and a location that is convenient for the user. The harness should be routed in a manner that protects it from chaffing and high heat sources. The switch and harness are considered to be “weather resistant”. A mounting locating that keeps it out of direct road or tire spray should be considered to help prevent issues.

## FLUID (NOT SUPPLIED)

Automatic transmission fluid (ATF) that meets a Dexron specification (such as a multipurpose) is the recommended fluid for use in all EQ Systems hydraulic pumps. Using ATF Dexron provides good operation for most climates that the systems will be used in. The use of a Synthetic ATF Fluid may be used if the system needs to be used in extreme cold conditions (-20 F or below). Fluids heavier than ATF such as ISO 32 or 46 hydraulic oils are not recommended as poor or no operation could occur in cold climate.

## UNI-ROTATIONAL PUMP POWER CONNECTIONS (SEE DRAWING # P 7073)

Battery (power supply) requirement (not supplied): The jack system is a high current draw unit requiring “direct” connection to a battery capable of providing at least 120 amperes @ 12 VDC. The battery should be a deep cycle RV-Marine type, recommended minimum group 24. A provision to keep the battery in a good state of charge must be employed for proper operation of the jack system.

**Pump Positive (+12 volts DC):** A wire (minimum #4 gauge) must be connected from the battery terminal on the motor solenoid to the positive (+12v) of the battery. This terminal will also have a 14 gauge red wire feeding a red fuse holder. If circuit protection is required, a circuit breaker with a minimum rating of 120 amps is required at the battery. If a main power disconnect switch is used to “kill” the power to the pump, it must have a rating of at least 120 amps. Heat shrink may be used to protect terminals and wire from corrosion and shorting.

**Pump Ground (-12 volts DC):** A 5/16” stud is provided at the port plate, next to the directional valve, to attach a wire (minimum #4 gauge) to the negative (-12v) of the battery. It is not acceptable to use the frame of the vehicle or trailer as the sole grounding connection. Heat shrink may be used to protect terminals and wire from corrosion and shorting.

Note: For power and ground, if the run length is longer than 12 feet the use of larger gauge wire (cable) such as 2 gauge may be needed.

**Switch & Harness Connection:** The 6 way (white in color) connector on the pump assembly mates with the connector on the end of the switch and harness assembly.

The use of corrosion preventative spray or grease may be used on electrical terminals to help prevent corrosion.



# UNI-ROTATIONAL PUMP HYDRAULIC HOSE CONNECTIONS

(SEE DRAWING # P 7073)

## Selector Valve Control

These units have a single rocker switch on the switch box. The selector valve has two manual twist style valves with knobs. One is for the left jack and the other is for the right jack.

**Hose Connections Top Port:** On the selector valve there are two fittings. These are connected to the top of the jack legs. One to the left jack and one to the right jack.

**Hose Connections Bottom Port:** A tee fitting exits the pump center plate between the motor and the reservoir. This is the retract port and must be connected to the bottom fitting of each jack. It does not matter which one is the left or right jack

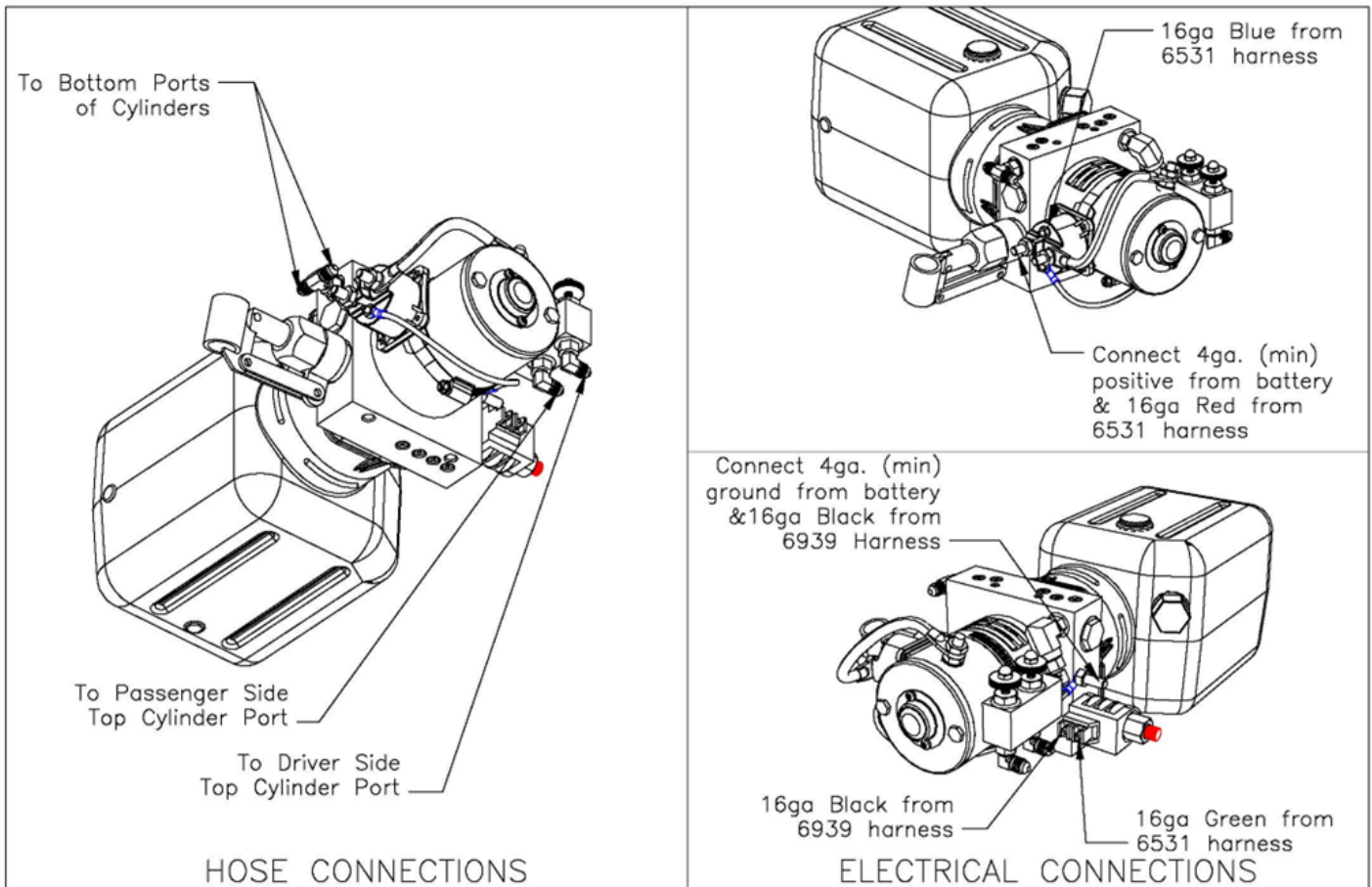

<b>Equalizer</b> 55169 COUNTY ROAD 3 ELKHART, IN 46515	#	REVISIONS	BY:	DATE:	UNLESS OTHERWISE SPECIFIED: TOLERANCES: .XXX ± 0.010 .XX ± 0.010 .X ± 0.030 ANG. ± 1/2° REMOVE ALL BURRS AND SHARP EDGES .015 MAX	TITLE	USED ON:
	A	CHANGED PUMP TO 3170	SJ	1/24/14		PUMP ASSEMBLY	DUAL LEG SYSTEM
NOTICE - This drawing, including principles of design, is the property of Daye Corporation, Elkhart, Indiana, with the agreement that it is not to be reproduced, copied, or loaned in any manner that may constitute a detriment directly or indirectly to Daye Corporation. Acceptance of this will be construed as an agreement of the above.						SIZE SCALE MATERIAL A 1:1	
						DRW BY: DATE: SJ 10/2/12	PART NAME: PUMP & MANU DUAL FUNC MANU CONTROL
						APP'D BY: DATE: - -	PAGE: DWG NO.: REV: 3 OF 3 P7073 A

# UNI-ROTATIONAL PUMP HYDRAULIC FLUID PURGING

(Only applies to AM-2 systems that are equipped with hand pump for override)

This procedure should be performed with the initial installation and running of hydraulic system following installation of the pump assembly and jacks. All electrical and hose connections must be completed before the purging process.

Fill the reservoir with ATF (Dexron). Run the pump to extend the jacks (see operation). Maintain the fluid level in the reservoir approximately  $\frac{1}{2}$  full. Do not allow reservoir to run empty. If jack(s) will not fully extend, crack loose the upper hose(s) at the jack(s) and run pump extend until air is expelled. Retighten the hoses and complete the extension of the jack(s).

Run the pump to retract the jacks. Maintain the fluid level as above. Do not fill too full until after the legs are fully retracted. If fluid in reservoir appears to be aerated (foaming), allow unit to sit until foam dissipates. Approximately 5-10 minutes. Fully extend and retract jacks a minimum of three times. Allow foamed oil to dissipate as needed. Maintain the fluid level in the reservoir as needed.

## **Additional Notes for Purging of Uni-Rotational Pump**

The reservoir fluid level will be greatest when the jacks are fully retracted and lowest when jacks are fully extended. Never allow the reservoir to go empty. Maintain the fluid level at least  $\frac{1}{4}$  full all the time. This  $\frac{1}{4}$  line should be clear fluid, not foamed up fluid. The fuller the reservoir is, the better- just remember that the level will rise as the jacks are retracted. If it is too full when the jacks are extended, the reservoir will overflow out of the breather cap when the jacks are retracted.

Be patient. It does no good to run the pump and try to move the jacks when the reservoir is full of foam. Pumping foam will only reintroduce air into the system. You want the air out. Allowing the air to dissipate through the reservoir and maintaining the reservoir fluid level will get things working faster.

# OPERATION OF DUAL LEG JACKS

## **Selector Valve**

These systems have one rocker switch on the switch box and a turn style valve manifold at the pump. There are 2 selector valves (one for each jack) on the manifold. To operate, turn the battery power disconnect switch to the on position. Then use the rocker switch to extend or retract the jacks. The selector valve(s) must be in the open (counter-clockwise) for the jacks to operate. The selector valves may be partly opened or closed to meter (control) the jacks' speed and extension independently. The selector valves need to be turned to the closed (clockwise) position to ensure that the trailer stays in the fixed position and that fluid pressure/volume does not transfer from one jack to the other- causing the trailer to lean to one side based on weight distribution. For safety and security, the battery power disconnect switch must be turned to the off position for travel or storage.

## Manual Override

EQ Systems' dual leg systems are designed with an **Override Feature** to operate the jacks in the event of an electrical or power failure. For this feature to be effective the hydraulic system must be sound (free of excessive leaks) and there must be oil in the reservoir. The directional control valve must be accessible and properly functioning for this to work.

### Uni-Directional Pumps with Selector Valve Using Hand Pump (See Drawing)

1. Locate the two selector valves. Open the valves completely by turning them out (counterclockwise) until they stop.
2. To extend the jacks, locate the hand pump and insert the handle. Operate the handle back and forth. The jack(s) should extend slightly with each stroke. It may take a few strokes for it to get started.
3. To retract the jacks, locate the red knob on the end of the directional control valve. Pull out on the red knob and turn it  $\frac{1}{4}$  turn so that it stays in the out position. Do not use pliers on this knob- use only your fingers. Insert the handle into the hand pump and operate the hand pump back and forth. The jack(s) should retract slightly with each stroke (it may take a few strokes for it to get started).
4. After override is complete return the red knob at the directional valve to the in position by turning it so that it finds its "spring-in" position.

**NOTE:** The directional control valve knob can be damaged if piers or other tools are used on the knob. **Only shift (operate) this valve using your fingers.** If the knob or valve stem is bent or shows any signs of damage, (impact or tool marks) it should be replaced.

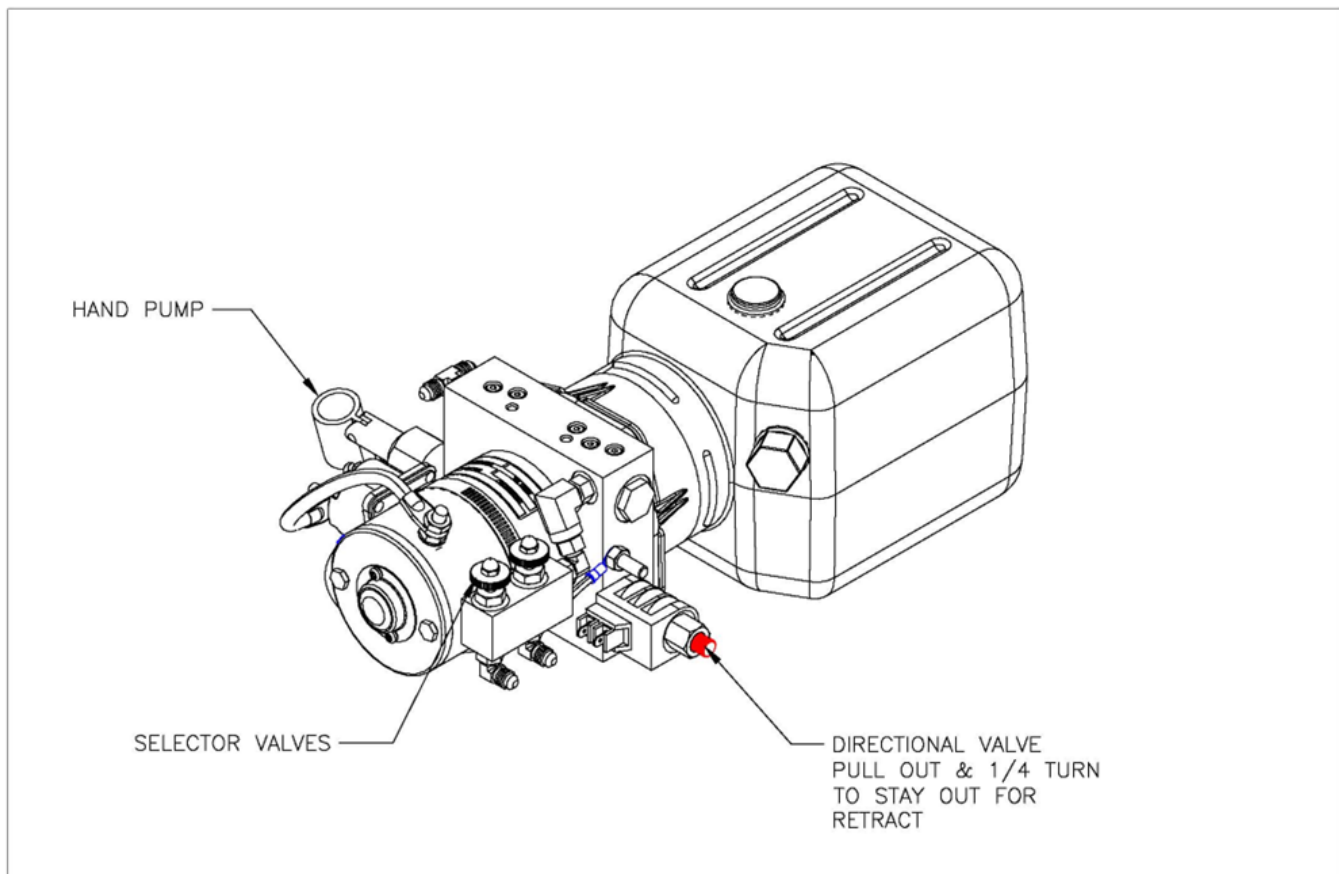

# HINTS / FAQ AND PROBLEM SOLVING

## FOR SINGLE AND DUAL LEG TRAILER JACKS

### **The jack(s) run for a few seconds then stop(s)**

Generally this is caused by a weak or defective battery. Charge the battery and retry. It may be necessary to have the battery tested and/or replaced.

### **The jack(s) only extend regardless of which way I push the switch**

Generally this is caused by a weak battery or poor connections. On units that have the uni-rotational pump, the directional valve must receive at least 10.5 VDC for it to properly shift. Charge the battery, check the connections for connectivity or corrosion and retry.

### **I push the switch and nothing happens**

Check the wiring connections at the battery and the pump assembly for looseness or corrosion. Check the disconnect switch or the key switch to assure (if equipped) that it is in the "ON" position. Check for a tripped circuit breaker. Some units have a fuse holder at the wiring near the pump. If so, check the fuse. Verify that the battery is not dead.

### **Most of the time its works fine, sometimes not at all and then later it works again or sometimes it just clicks**

Most no-run, intermittent operation, or operation in only one direction is due to a dead or weak battery. Or possibly a battery that is not being properly charged by the charging system and/or loose or corroded electrical connections. Check out the vehicle electrical system to include the battery and the charging system for possible issues.

### **Why do I need a ground? Isn't my jack bolted to the trailer?**

Do not ignore the ground. EQ recommends that a 4 gauge wire cable be run from the battery negative terminal to the body of the jack to assure a good connection. Failure to do so invites a poor ground connection due to painted surfaces or corrosion build up between the jack and the trailer. This is especially important if the mounting is relied upon for grounding on aluminum trailers, as corrosion will build up between the jack and the trailer. Also most battery-to-trailer grounds are of smaller than needed wire gauge size as they were designed to operate lighting or other low current draw devices. The jack is a high current draw item requiring a "heavy" gauge ground.

### **My trailer lowered overnight. Why did the jack(s) do this?**

There are three basic reasons for this. First look for any signs of external fluid loss (leakage). Generally if there is a leak it will be due to a loose fitting or adaptor. If no external fluid leaks are present, the issue is with the hydraulic cylinder seal or with the hold-check (valve) in the pump. You will need to record the numbers from the pump assembly and call EQ Systems to get these items addressed.



### **When retracting my jack(s) it bounces or jerks – Why?**

The first possibility is that there is air in the system. Check the fluid level in the reservoir. Add fluid if needed. Then cycle the jack to full extension and then full retraction 3 times to purge the air out. If the fluid is foamy between cycles allow it to sit until the foam dissipates. On systems that are at or over the maximum lifting capacity, a very slight “pulse” may be normal during retraction. For excessive “pulsing” (bouncing) call EQ Systems as there may be an issue with the flow control or pump check valve.

### **My dual legs jacks operate at different speeds –Why?**

The fluid from the pump will flow faster to the leg where there is the least resistance. If equipped with the selector valves, adjust them so that the jack speed is the same. Generally when running the jacks to take up ground clearance there may be some difference and then when the fast one hits the ground, the slower one will speed up and catch up to the other jack.

### **What happens if I lose my keys?**

You may be able to buy new keys from EQ Systems if you know the key code. If you do not know the key code you will need to replace the key switch assembly. In an emergency you will need to perform the manual override procedure outlined in your owner’s manual.

### **My Jack won’t work, how do I manually override?**

The manual override procedure is different depending on the type of pump assembly and control that is on your specific system. You will need to know which type you have. See the manual override section of the owner’s manual for this.

### **I need parts, how do I find and where do I go?**

You will need the number from the pump assembly and perhaps some measurements of the jack leg(s). You can go to the replacement parts section of our online store [www.eqsystems.us](http://www.eqsystems.us) to order or you can call us at **800-846-9659**. You can also contact your dealer for assistance.