



TJ SERIES

Installation/Operation/Warranty Guide

Effective January 2012

EQ006R7



(800) 846-9659
EQSystems.us

TJ SERIES

Hydraulic Trailer Tongue Jack System - 8065M

INSTALLATION

Tools Required for Installation

- Ratchet, sockets and wrench set
- ½ inch Allen wrench (hex key)
- Wire cutters/crimpers
- Electric drill and bits
- Screw gun bit

Additional Parts Needed for Installation

- #6 gauge power wire (to connect battery +12V to the pump motor contactor)
- #6 gauge ground wire (to connect battery ground to pump motor contactor)
- #6 gauge ring terminals
- Wire ties
- Loctite® #242 or equivalent
- Dexron® Automatic Transmission Fluid



SYSTEM MOUNTING

Jack Leg

Remove the existing manual jack from the trailer frame. Be sure to support the trailer weight with appropriate size jack stands.

The TJ style jack is shipped without the foot attached. Slide the jackleg cylinder through the A-frame mounting flange. Secure using the supplied 3/8 inch bolts, flats washers, and locking nuts. If alternate bolts are used, the bolts must be grade 5 minimum.

Jack Foot

Locate the jack foot (part #1389) and the $\frac{3}{4}$ -10 X 1 $\frac{1}{4}$ screw (part #1383).

Attach the foot to the jack legs using the $\frac{3}{4}$ -10 X 1 $\frac{1}{4}$ screw. Use Loctite® #242 or equivalent and tighten securely.

SWITCH HARNESS AND HYDRAULIC LINES

The TJ series jack has been shipped with all necessary switchgear, harnesses and hydraulic lines. These items are specifically engineered to operate your system and should not be altered in any manner. Modification of any factory-supplied item may result in the denial of all warranty claims.

BATTERY CONNECTIONS

(Also see photo and schematic)

Battery Lead (+12volts): Attach a # 6-gauge (minimum) wire between the positive +12 volt terminal on the battery and the plus (+) terminal on the motor contactor; shown in Fig 2. There is a small red wire on this terminal. If circuit protection is required, install an 80 amp (minimum) circuit breaker.

Pump Ground (-12volts): Attach a #6 gauge (minimum) wire between the negative -12 volt terminal on the battery and the negative terminal on the contactor. There is a small black wire on this terminal.

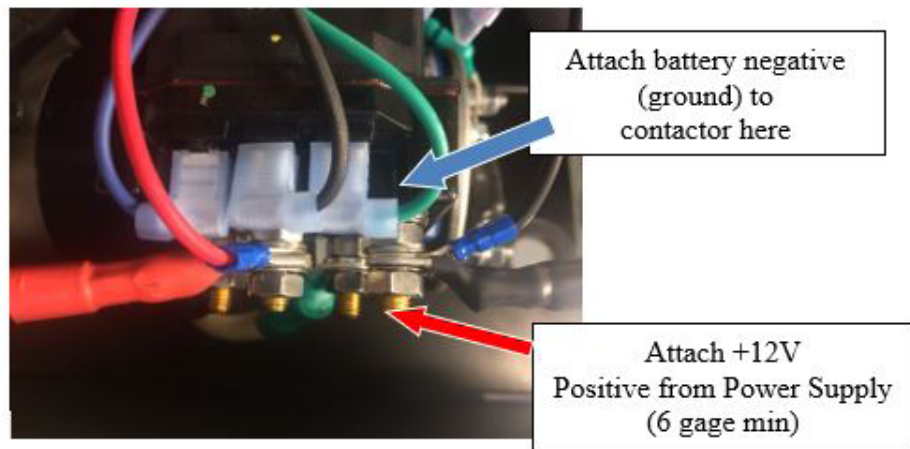

Reversing Contactor Wiring

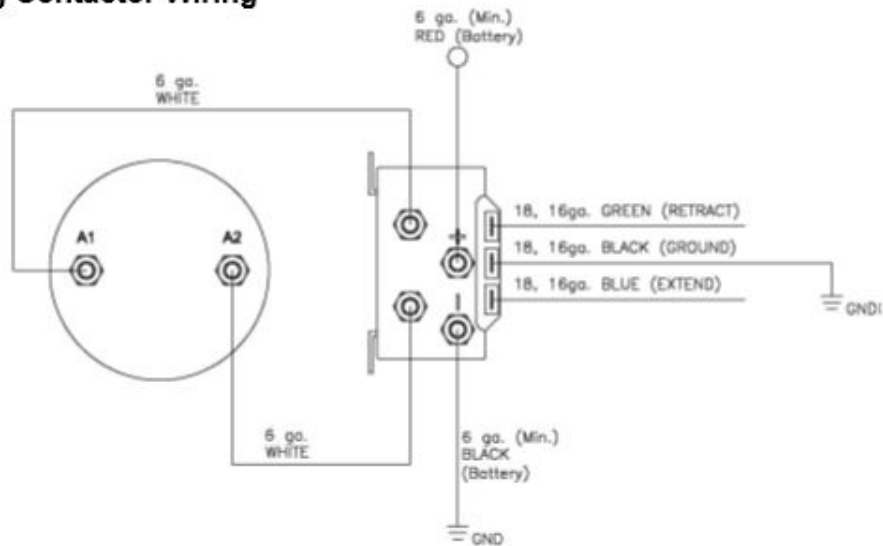

RESERVOIR BREATHER CAP

Remove the shipping plug from the reservoir fill port and discard. Install the supplied breather cap. Failure to install the breather cap will result in erratic jack operation.

RESERVOIR FLUID LEVEL

When the jack is fully retracted, the fluid level in the reservoir should be approximately one inch below the fill cap. If fluid needs to be added, use Dexron automatic transmission fluid (the same as used for a GM automobile).

OPERATION

To raise and lower the jack, simply push and hold the rocker switch in the up or down position. The jack will hold a position by releasing the switch at any time. There is no need to take the weight off the jack when storing the trailer, as the positive check valves in the system will not allow the jack to bleed down.

Warning: With any hydraulic application, holding any position on a cylinder must be done with safety in mind. Failure in the system may cause the leg to retract or extend on its own. When working under or near the trailer, always use jack stands of appropriate rating to support the weight of the trailer.

The keyed switch must be in the off position and the key must be removed when the jack is not in use and/or when the trailer is in transit. If unit is not supplied with a keyed switch, the +12v battery lead must be fed through a power disconnect switch to fully isolate the system during inactivity or travel. The minimum switch rating must be 80 ampere DC.

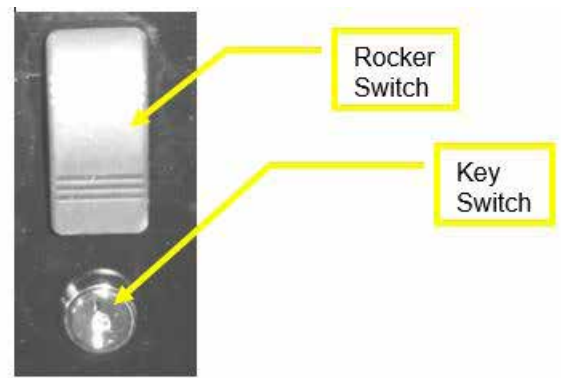

MANUAL OVERRIDE

The TJ series pump has provisions for manual override.

Before you begin this procedure, please read and understand these instructions.

Required Items:

- Reversible Drill- capable of producing a minimum of 2000 r.p.m.
- 6mm(1/4") Hex Key (Allen Wrench) bit or driver.

To override the jack:

Remove the foil seal from the top of the motor. Use a small flat head screwdriver if necessary.

Insert the 6mm (1/4") hex key (Allen) bit on the manual override shaft located at the top of the motor.

To Retract:

Run drill in the **clockwise** direction at 2000 r.p.m. (minimum). The jack will retract.

To Extend:

Run drill in the **counterclockwise** direction at 2000 r.p.m. (minimum). The jack will extend.

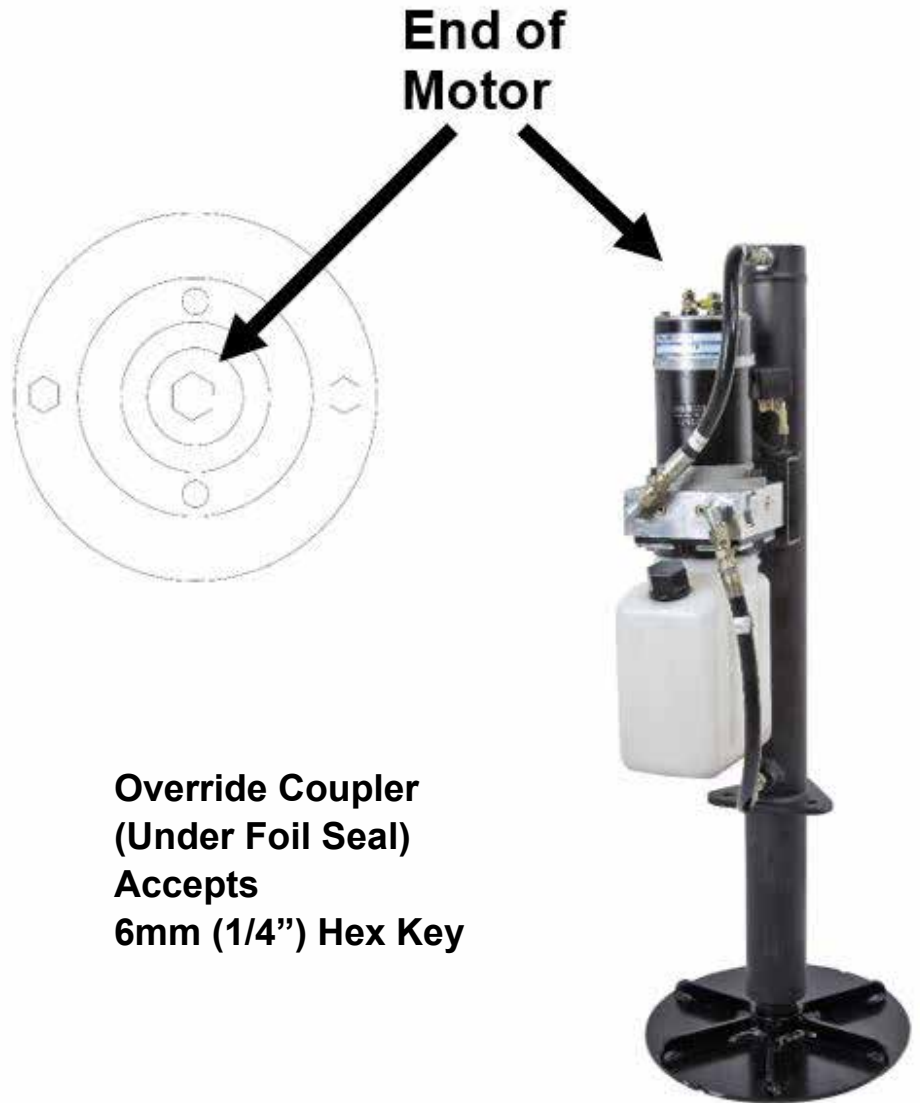

PROBLEM SOLVING

“The jack runs for a few seconds, then stops” The battery is weak or battery capacity is diminished. Charge the battery fully. It may be necessary to “load test” the battery.

“The jack only runs in one direction” Verify appropriate battery voltage. Verify that all wires are attached appropriately. Verify proper function of the switchgear.

“I push the switch and nothing happens” Ensure both positive and negative -12V have adequate connection. Ensure full charge on your battery. The vast majority of calls to the EQ Systems Help Desk are related to low battery voltage. Ensure that the unit is properly grounded to the battery with a minimum # 6-gauge wire. Check all associated wiring.

“The jack is jerky when retracting” This may be caused by air in the system, low fluid level, or incorrect hose installation. To purge leg, add fluid as necessary and run the leg to full extension and retraction at least twice. If problem persists, call EQ Systems for assistance.

Fluid Level: When the jack is fully retracted, the fluid level in the reservoir should be approximately one inch below the fill cap. If fluid needs to be added, use Dexron III automatic transmission fluid (the same as used for a GM automobile).