

2007 FOUR WINDS SLIDE REFERENCE

FUN MOVER

39C

SOFA 7164 SLIDE ASSBLY 36" FOUR WINDS

39D

SOFA/DIN 7164 SLIDE ASSBLY 36" FOUR WINDS

SUPER C

32B

SOFA/DIN 7164B SLIDE ASSBLY 36" FOUR WINDS

33K ALL SLIDES ARE ELECTRIC

34G ALL SLIDES ARE ELECTRIC

35B

SOFA/DIN 7164B SLIDE ASSBLY 36" FOUR WINDS
BED ELECTRIC (LIPPERT)

HURRICANE

30F

SOFA/DIN 7164 SLIDE ASSBLY 36" FOUR WINDS

31D ALL SLIDES ARE ELECTRIC

31H ALL SLIDES ARE ELECTRIC

32R

SOFA/DIN. 7164 SLIDE ASSBLY 36" FOUR WINDS
BED 7303-CYLINDER-BED SLIDE-FOUR WINDS
(SLIDE BUILT BY POWER GEAR)

33H

SOFA/DIN 7164 SLIDE ASSBLY 36" FOUR WINDS

34B

SOFA/DIN. 7164 SLIDE ASSBLY 36" FOUR WINDS
BED LIPPERT SLIDE AND CYLINDER
BUNK BED 7135 SLIDE ASSBLY 18" FOUR WINDS

34N

SOFA/DIN. 7164 SLIDE ASSBLY 36" FOUR WINDS
BED 7303-CYLINDER-BED SLIDE-FOUR WINDS
(SLIDE BUILT BY POWER GEAR)
KITCHEN 7135 SLIDE ASSBLY 18" FOUR WINDS

34S

SOFA/DIN. 7164 SLIDE ASSBLY 36" FOUR WINDS
BED LIPPERT SLIDE AND CYLINDER
BUNK BED 7135 SLIDE ASSBLY 18" FOUR WINDS

WINDSPORT

32R

SOFA/DIN 7164 SLIDE ASSBLY 36" FOUR WINDS
BED 7303-CYLINDER-BED SLIDE-FOUR WINDS
(SLIDE BUILT BY POWER GEAR)

35B

SOFA/DIN 7164 SLIDE ASSBLY 36" FOUR WINDS
BED LIPPERT SLIDE AND CYLINDER
KITCHEN 7135 SLIDE ASSBLY 18" FOUR WINDS

36E

SOFA/DIN 7164 SLIDE ASSBLY 36" FOUR WINDS
BED 7303-CYLINDER-BED SLIDE-FOUR WINDS
(SLIDE BUILT BY POWER GEAR)
WARDROBE 7135 SLIDE ASSBLY 18" FOUR WINDS

36Z

SOFA/DIN 7164 SLIDE ASSBLY 36" FOUR WINDS
BED 7303-CYLINDER-BED SLIDE-FOUR WINDS
(SLIDE BUILT BY POWER GEAR)

MAGELLAN

35B

SOFA/DIN 7164D SLIDE ASSBLY 36" FOUR WINDS (2 REQ'D WITH
7351 SYNC CYL)
BED LIPPERT SLIDE AND CYLINDER
KITCHEN 7135 SLIDE ASSBLY 18" FOUR WINDS

36E

SOFA/DIN 7164D SLIDE ASSBLY 36" FOUR WINDS (2 REQ'D WITH
7351 SYNC CYL)
BED 7303-CYLINDER-BED SLIDE-FOUR WINDS
(SLIDE BUILT BY POWER GEAR)
WARDROBE 7135 SLIDE ASSBLY 18" FOUR WINDS

36K

SOFA/DIN 7164D SLIDE ASSBLY 36" FOUR WINDS (2 REQ'D WITH
7351 SYNC CYL)
BED 7303-CYLINDER-BED SLIDE-FOUR WINDS
(SLIDE BUILT BY POWER GEAR)
WARDROBE 7135 SLIDE ASSBLY 18" FOUR WINDS

36Z

SOFA/DIN 7164D SLIDE ASSBLY 36" FOUR WINDS (2 REQ'D WITH
7351 SYNC CYL)
BED 7303-CYLINDER-BED SLIDE-FOUR WINDS
(SLIDE BUILT BY POWER GEAR)

38E

SOFA/DIN 7164D SLIDE ASSBLY 36" FOUR WINDS (2 REQ'D WITH
7351 SYNC CYL)
VANITY 7135 SLIDE ASSBLY 18" FOUR WINDS
BED 7303-CYLINDER-BED SLIDE-FOUR WINDS
(SLIDE BUILT BY POWER GEAR)
KITCHEN 7135 SLIDE ASSBLY 18" FOUR WINDS

VALENCIA

36A

SOFA/DIN 7164D SLIDE ASSBLY 36" FOUR WINDS (2 REQ'D WITH
7351 SYNC CYL)
BED 7303-CYLINDER-BED SLIDE-FOUR WINDS
(SLIDE BUILT BY POWER GEAR)

36B

SOFA/DIN 7164D SLIDE ASSBLY 36" FOUR WINDS (2 REQ'D WITH
7351 SYNC CYL)
BED LIPPERT SLIDE AND CYLINDER
KITCHEN 7135 SLIDE ASSBLY 18" FOUR WINDS

37A

SOFA/DIN 7164D SLIDE ASSBLY 36" FOUR WINDS (2 REQ'D WITH
7351 SYNC CYL)
BED 7303-CYLINDER-BED SLIDE-FOUR WINDS
(SLIDE BUILT BY POWER GEAR)
VANITY 7135 SLIDE ASSBLY 18" FOUR WINDS

38C

SOFA/DIN 7164D SLIDE ASSBLY 36" FOUR WINDS (2 REQ'D WITH
7351 SYNC CYL)
BED 7303-CYLINDER-BED SLIDE-FOUR WINDS
(SLIDE BUILT BY POWER GEAR)
VANITY 7135 SLIDE ASSBLY 18" FOUR WINDS
KITCHEN 7135 SLIDE ASSBLY 18" FOUR WINDS

PRESIDIO

39A

SOFA/DIN 7164D SLIDE ASSBLY 36" FOUR WINDS (2 REQ'D WITH
7351 SYNC CYL)
BED 7303-CYLINDER-BED SLIDE-FOUR WINDS
(SLIDE BUILT BY POWER GEAR)
VANITY 7135 SLIDE ASSBLY 18" FOUR WINDS
KITCHEN 7135 SLIDE ASSBLY 18" FOUR WINDS

39B

SOFA/DIN 7164D SLIDE ASSBLY 36" FOUR WINDS (2 REQ'D WITH
7351 SYNC CYL)
BED 7303-CYLINDER-BED SLIDE-FOUR WINDS
(SLIDE BUILT BY POWER GEAR)
VANITY 7135 SLIDE ASSBLY 18" FOUR WINDS
KITCHEN 7135 SLIDE ASSBLY 18" FOUR WINDS

39C

SOFA/DIN 7164D SLIDE ASSBLY 36" FOUR WINDS (2 REQ'D WITH
7351 SYNC CYL)
VANITY 7135 SLIDE ASSBLY 18" FOUR WINDS
BED 7303-CYLINDER-BED SLIDE-FOUR WINDS
(SLIDE BUILT BY POWER GEAR)
KITCHEN 7135 SLIDE ASSBLY 18" FOUR WINDS

39D

KITCHEN	7135 SLIDE ASSBLY 18" FOUR WINDS
BED	7303-CYLINDER-BED SLIDE-FOUR WINDS (SLIDE BUILT BY POWER GEAR)
VANITY	7135 SLIDE ASSBLY 18" FOUR WINDS
SOFA/DIN	7164D SLIDE ASSBLY 36" FOUR WINDS (2 REQ'D WITH 7351 SYNC CYL)

39E

KITCHEN	7369 SLIDE ASSBLY 24" FOUR WINDS (2 REQ'D WITH 7351 SYNC CYL)
BED	LIPPERT SLIDE AND CYLINDER
VANITY	7135 SLIDE ASSBLY 18" FOUR WINDS
SOFA/DIN	7164D SLIDE ASSBLY 36" FOUR WINDS (2 REQ'D WITH 7351 SYNC CYL)

2007 FOUR WINDS SLIDE REFERENCE

HURRICANE

30F

SOFA/DIN 7164 SLIDE ASSBLY 36" FOUR WINDS

31D ALL SLIDES ARE ELECTRIC

31H ALL SLIDES ARE ELECTRIC

32R

SOFA/DIN. 7164 SLIDE ASSBLY 36" FOUR WINDS
BED 7303-CYLINDER-BED SLIDE-FOUR WINDS
(SLIDE BUILT BY POWER GEAR)

33H

SOFA/DIN 7164 SLIDE ASSBLY 36" FOUR WINDS

34B

SOFA/DIN. 7164 SLIDE ASSBLY 36" FOUR WINDS
BED LIPPERT SLIDE AND CYLINDER
BUNK BED 7135 SLIDE ASSBLY 18" FOUR WINDS

34N

SOFA/DIN. 7164 SLIDE ASSBLY 36" FOUR WINDS
BED 7303-CYLINDER-BED SLIDE-FOUR WINDS
(SLIDE BUILT BY POWER GEAR)
KITCHEN 7135 SLIDE ASSBLY 18" FOUR WINDS

WINDSPORT

31D ALL SLIDES ARE ELECTRIC

31H ALL SLIDES ARE ELECTRIC

32R

SOFA/DIN 7164 SLIDE ASSBLY 36" FOUR WINDS
BED 7303-CYLINDER-BED SLIDE-FOUR WINDS
(SLIDE BUILT BY POWER GEAR)

35B

SOFA/DIN 7164 SLIDE ASSBLY 36" FOUR WINDS
BED LIPPERT SLIDE AND CYLINDER
KITCHEN 7135 SLIDE ASSBLY 18" FOUR WINDS

36E

SOFA/DIN 7164 SLIDE ASSBLY 36" FOUR WINDS
BED 7303-CYLINDER-BED SLIDE-FOUR WINDS
(SLIDE BUILT BY POWER GEAR)
WARDROBE 7135 SLIDE ASSBLY 18" FOUR WINDS

36Z

SOFA/DIN 7164 SLIDE ASSBLY 36" FOUR WINDS
BED 7303-CYLINDER-BED SLIDE-FOUR WINDS
(SLIDE BUILT BY POWER GEAR)

MAGELLAN

35B

SOFA/DIN 7164D SLIDE ASSBLY 36" FOUR WINDS (2 REQ'D WITH
7351 SYNC CYL)
BED LIPPERT SLIDE AND CYLINDER
KITCHEN 7135 SLIDE ASSBLY 18" FOUR WINDS

36E

SOFA/DIN 7164D SLIDE ASSBLY 36" FOUR WINDS (2 REQ'D WITH
7351 SYNC CYL)
BED 7303-CYLINDER-BED SLIDE-FOUR WINDS
(SLIDE BUILT BY POWER GEAR)
WARDROBE 7135 SLIDE ASSBLY 18" FOUR WINDS

36K

SOFA/DIN 7164D SLIDE ASSBLY 36" FOUR WINDS (2 REQ'D WITH
7351 SYNC CYL)
BED 7303-CYLINDER-BED SLIDE-FOUR WINDS
(SLIDE BUILT BY POWER GEAR)
WARDROBE 7135 SLIDE ASSBLY 18" FOUR WINDS

36Z

SOFA/DIN 7164D SLIDE ASSBLY 36" FOUR WINDS (2 REQ'D WITH
7351 SYNC CYL)
BED 7303-CYLINDER-BED SLIDE-FOUR WINDS
(SLIDE BUILT BY POWER GEAR)

38E

SOFA/DIN 7164D SLIDE ASSBLY 36" FOUR WINDS (2 REQ'D WITH
7351 SYNC CYL)
VANITY 7135 SLIDE ASSBLY 18" FOUR WINDS
BED 7303-CYLINDER-BED SLIDE-FOUR WINDS
(SLIDE BUILT BY POWER GEAR)
KITCHEN 7135 SLIDE ASSBLY 18" FOUR WINDS

VALENCIA

36A

SOFA/DIN	7164D SLIDE ASSBLY 36" FOUR WINDS (2 REQ'D WITH 7351 SYNC CYL)
BED	7303-CYLINDER-BED SLIDE-FOUR WINDS (SLIDE BUILT BY POWER GEAR)

36B

SOFA/DIN	7164D SLIDE ASSBLY 36" FOUR WINDS (2 REQ'D WITH 7351 SYNC CYL)
BED	LIPPERT SLIDE AND CYLINDER
KITCHEN	7135 SLIDE ASSBLY 18" FOUR WINDS

37A

SOFA/DIN	7164D SLIDE ASSBLY 36" FOUR WINDS (2 REQ'D WITH 7351 SYNC CYL)
BED	7303-CYLINDER-BED SLIDE-FOUR WINDS (SLIDE BUILT BY POWER GEAR)
VANITY	7135 SLIDE ASSBLY 18" FOUR WINDS

38C

SOFA/DIN	7164D SLIDE ASSBLY 36" FOUR WINDS (2 REQ'D WITH 7351 SYNC CYL)
BED	7303-CYLINDER-BED SLIDE-FOUR WINDS (SLIDE BUILT BY POWER GEAR)
VANITY	7135 SLIDE ASSBLY 18" FOUR WINDS
KITCHEN	7135 SLIDE ASSBLY 18" FOUR WINDS

PRESIDIO

39A

SOFA/DIN	7164D SLIDE ASSBLY 36" FOUR WINDS (2 REQ'D WITH 7351 SYNC CYL)
BED	7303-CYLINDER-BED SLIDE-FOUR WINDS (SLIDE BUILT BY POWER GEAR)
VANITY	7135 SLIDE ASSBLY 18" FOUR WINDS
KITCHEN	7135 SLIDE ASSBLY 18" FOUR WINDS

39B

SOFA/DIN	7164D SLIDE ASSBLY 36" FOUR WINDS (2 REQ'D WITH 7351 SYNC CYL)
BED	7303-CYLINDER-BED SLIDE-FOUR WINDS (SLIDE BUILT BY POWER GEAR)
VANITY	7135 SLIDE ASSBLY 18" FOUR WINDS
KITCHEN	7135 SLIDE ASSBLY 18" FOUR WINDS

39C

SOFA/DIN 7164D SLIDE ASSBLY 36" FOUR WINDS (2 REQ'D WITH
7351 SYNC CYL)
VANITY 7135 SLIDE ASSBLY 18" FOUR WINDS
BED 7303-CYLINDER-BED SLIDE-FOUR WINDS
(SLIDE BUILT BY POWER GEAR)
KITCHEN 7135 SLIDE ASSBLY 18" FOUR WINDS

39D

KITCHEN 7135 SLIDE ASSBLY 18" FOUR WINDS
BED 7303-CYLINDER-BED SLIDE-FOUR WINDS
(SLIDE BUILT BY POWER GEAR)
VANITY 7135 SLIDE ASSBLY 18" FOUR WINDS
SOFA/DIN 7164D SLIDE ASSBLY 36" FOUR WINDS (2 REQ'D WITH
7351 SYNC CYL)

39E

KITCHEN 7369 SLIDE ASSBLY 24" FOUR WINDS (2 REQ'D WITH
7351 SYNC CYL)
BED LIPPERT SLIDE AND CYLINDER
VANITY 7135 SLIDE ASSBLY 18" FOUR WINDS
SOFA/DIN 7164D SLIDE ASSBLY 36" FOUR WINDS (2 REQ'D WITH
7351 SYNC CYL)

**30F HURRICANE (19.5) TIRES
EQUALIZER JACKS (FULLY AUTOMATIC)
STANDARD ON THIS UNIT**

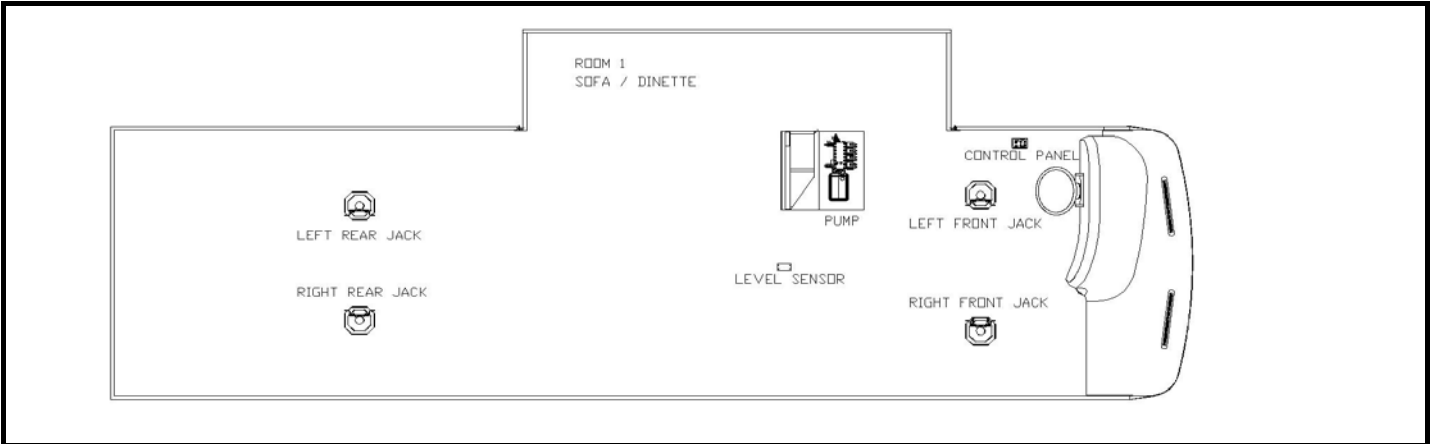

Notes:

1) Jacks mount in two different locations on bracket depending on tire size of chassis.

a) 19.5 Tires: Top hole in jack to top hole in bracket. Use 4 bolts in welded area of bracket.

b) 22.5 Tires: Top hole in jack to second hole in bracket. Use 6 bolts, 4 in welded area of bracket & 2 below welded area.

Item, Length	Description / Location	Qty	Color	Vendor PN		
Kit	(Items listed below)	1		8267	Measuring from inside of firewall, this is the end location of the hydraulic hoses where they attach to the slide mechanism.	
Pump	5-Function, 1 Room, Jacks	1		7242		
Jack	12,000 lbs, 16" Stroke	4		7214		
Control Panel	Located to the left of the drivers seat	1		2057		
Level Sensor	Attached to bottom of structure	1		7196		
Flow Divider	Mounted inside pump compartment	N/A		N/A		
Hose, 140	Pump to Jack, Left Front	2	Brown	7294		
Hose, 240	Pump to Jack, Left Rear	2	Orange	7295		
Hose, 180	Pump to Jack, Right Front	2	White	7296		
Hose, 280	Pump to Jack, Right Rear	2	Yellow	7297		
Hose, N/A	Pump to Flow Divider	N/A	Green	N/A		N/A
Hose, N/A	Flow divider to front slide, Room 1	N/A	Green	N/A		N/A
Hose, N/A	Flow divider to rear slide, Room 1	N/A	Green	N/A		N/A
Hose, 48	Pump to Room 1	2	Green	7306		127 / Drivers Side
Hose, N/A	Pump to Room 2	N/A	Purple	N/A	N/A	
Hose, N/A	Pump to Room 3	N/A	Gray	N/A	N/A	
Hose, N/A	Pump to Room 4	N/A	Red	N/A	N/A	
Hose, N/A	Pump to Generator Slide	N/A		N/A	N/A	
Travel Clamp	Two per Slide	N/A		HWH	N/A	

Options

Revisions

1	Change hose length fro room 1 from 32 to 48 (10/19/05 MJK)

**34B/34S HURRICANE (19.5) TIRES
EQUALIZER JACKS (FULLY AUTOMATIC)
STANDARD ON THIS UNIT**

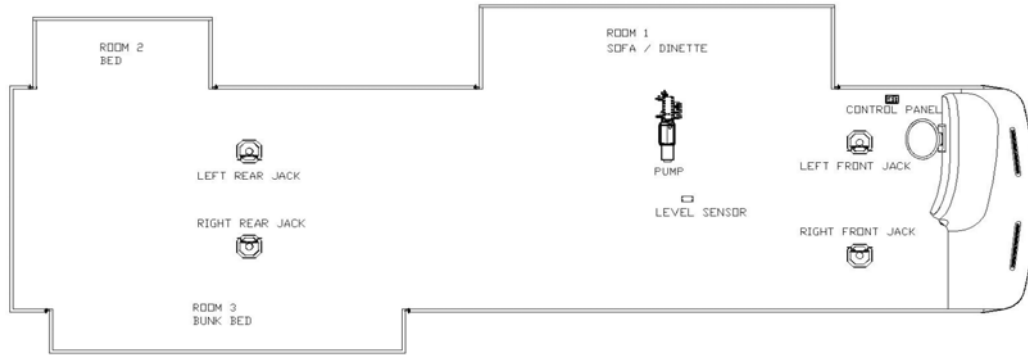

Notes:

1) Jacks mount in two different locations on bracket depending on tire size of chassis.

a) 19.5 Tires: Top hole in jack to top hole in bracket. Use 4 bolts in welded area of bracket.

b) 22.5 Tires: Top hole in jack to second hole in bracket. Use 6 bolts, 4 in welded area of bracket & 2 below welded area.

Item, Length	Description / Location	Qty	Color	Vendor PN	
Kit	(Items listed below)	1		8323	
Pump	7-Function, 3 Rooms, Jacks	1		7301	
Jack	12,000 lbs, 16" Stroke	4		7214	
Touch Pad	Located to the left of the drivers seat	1		2318	
Control Box	Attached to bottom of structure	1		2319	
Flow Divider	Mounted inside pump compartment	N/A		N/A	
Hose, 144	Pump to Jack, Left Front	2	Brown	2467	
Hose, 264	Pump to Jack, Left Rear	2	Orange	2476	
Hose, 180	Pump to Jack, Right Front	2	White	2470	
Hose, 300	Pump to Jack, Right Rear	2	Yellow	2479	
Hose, N/A	Pump to Flow Divider	N/A	Green	N/A	N/A
Hose, N/A	Flow divider to front slide, Room 1	N/A	Green	N/A	N/A
Hose, N/A	Flow divider to rear slide, Room 1	N/A	Green	N/A	N/A
Hose, 36	Pump to Room 1	2	Green	2458	127 / Drivers Side
Hose, 372	Pump to Room 2	2	Purple	2481	341 / Drivers Side
Hose w90, 372	Pump to Room 3	2	Gray	2481	300 / Passenger Side
Hose, N/A	Pump to Room 4	N/A	Red	N/A	N/A
Hose, N/A	Pump to Generator Slide	N/A	N/A	N/A	N/A
Travel Clamp	Two per Slide	N/A		HWH	N/A

Measuring from inside of firewall, this is the end location of the hydraulic hoses where they attach to the slide mechanism.

Options

Revisions

**34B/34S HURRICANE (19.5) TIRES
EQUALIZER JACKS (FULLY AUTOMATIC)
STANDARD ON THIS UNIT**

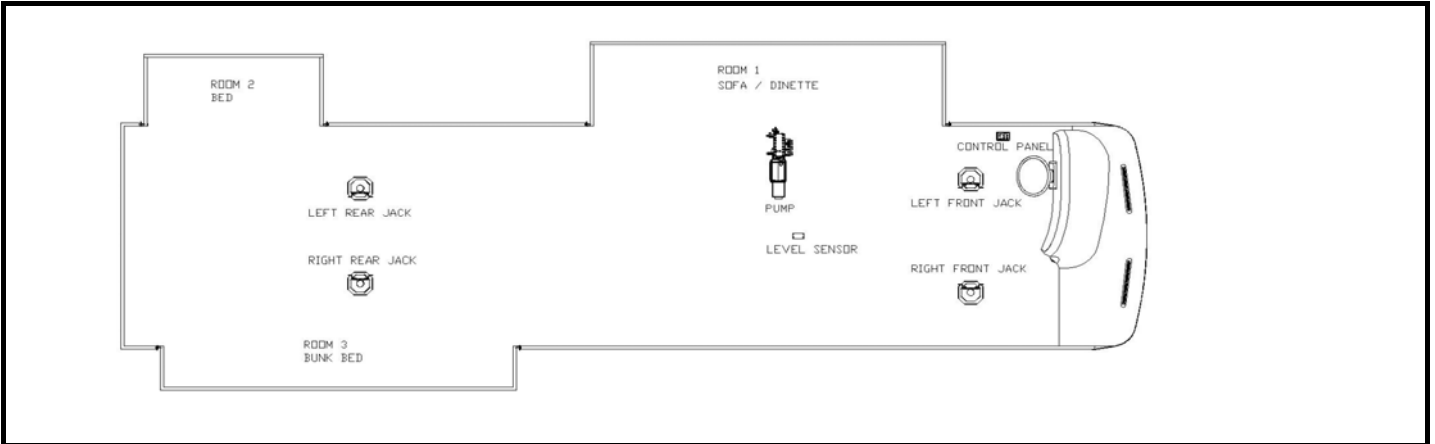

Notes:

- 1) Jacks mount in two different locations on bracket depending on tire size of chassis.
 - a) 19.5 Tires: Top hole in jack to top hole in bracket. Use 4 bolts in welded area of bracket.
 - b) 22.5 Tires: Top hole in jack to second hole in bracket. Use 6 bolts, 4 in welded area of bracket & 2 below welded area.

Item, Length	Description / Location	Qty	Color	Vendor PN		
Kit	(Items listed below)	1		8323	Measuring from inside of firewall, this is the end location of the hydraulic hoses where they attach to the slide mechanism.	
Pump	7-Function, 3 Rooms, Jacks	1		7301		
Jack	12,000 lbs, 16" Stroke	4		7214		
Touch Pad	Located to the left of the drivers seat	1		2318		
Control Box	Attached to bottom of structure	1		2319		
Flow Divider	Mounted inside pump compartment	N/A		N/A		
Hose, 144	Pump to Jack, Left Front	2	Brown	2467		
Hose, 264	Pump to Jack, Left Rear	2	Orange	2476		
Hose, 180	Pump to Jack, Right Front	2	White	2470		
Hose, 300	Pump to Jack, Right Rear	2	Yellow	2479		
Hose, N/A	Pump to Flow Divider	N/A	Green	N/A		N/A
Hose, N/A	Flow divider to front slide, Room 1	N/A	Green	N/A		N/A
Hose, N/A	Flow divider to rear slide, Room 1	N/A	Green	N/A		N/A
Hose, 36	Pump to Room 1	2	Green	2458		127 / Drivers Side
Hose, 372	Pump to Room 2	2	Purple	2481	341 / Drivers Side	
Hose w90, 372	Pump to Room 3	2	Gray	2481	300 / Passenger Side	
Hose, N/A	Pump to Room 4	N/A	Red	N/A	N/A	
Hose, N/A	Pump to Generator Slide	N/A	N/A	N/A	N/A	
Travel Clamp	Two per Slide	N/A		HWH	N/A	

Options

Revisions

**35 D FUNMOVER
EQUALIZER JACKS (FULLY AUTOMATIC)
OPTIONAL ON THIS UNIT**

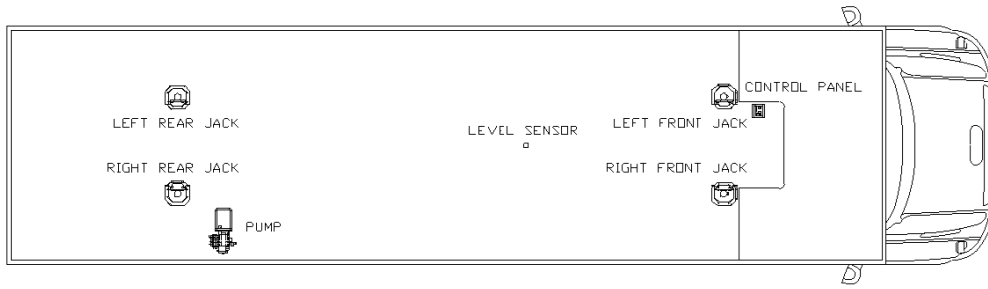

Notes:

1) Jacks mount 2nd hole from top to top mounting plate hole.

Item, Length	Description / Location	Qty	Color	Vendor PN		
Kit	(Items listed below)	1		8251	Measuring from back of cab floor, this is the end location of the hydraulic hoses where they attach to the slide mechanism.	
Pump	4-Function, Jacks Only	1		7239		
Jack	12,000 lbs, 16" Stroke	4		7214		
Touch Pad	Located to the right of the drivers seat	1		2318		
Control Box	Attached to bottom of structure	1		2319		
Flow Divider	Mounted inside pump compartment	N/A		N/A		
Hose, 300	Pump to Jack, Left Front	2	Brown	2479		
Hose, 108	Pump to Jack, Left Rear	2	Orange	2464		
Hose, 276	Pump to Jack, Right Front	2	White	2477		
Hose, 60	Pump to Jack, Right Rear	2	Yellow	2460		
Hose, N/A	Pump to Flow Divider	N/A	TBD	N/A		N/A
Hose, N/A	Flow divider to front slide, Room 1	N/A	TBD	N/A		N/A
Hose, N/A	Flow divider to rear slide, Room 1	N/A	TBD	N/A		N/A
Hose, N/A	Pump to Room 1	N/A	Green	N/A		N/A
Hose, N/A	Pump to Room 2	N/A	Purple	N/A		N/A
Hose, N/A	Pump to Room 3	N/A	Gray	N/A		N/A
Hose, N/A	Pump to Room 4	N/A	Red	N/A		N/A
Hose, N/A	Pump to Generator Slide	N/A	TBD	N/A		N/A
Travel Clamp	Two per Slide	N/A		HWH		N/A
Options						
Revisions	Description		By	Date		

36B Valencia
EQUALIZER JACKS (FULLY AUTOMATIC)
STANDARD ON THIS UNIT

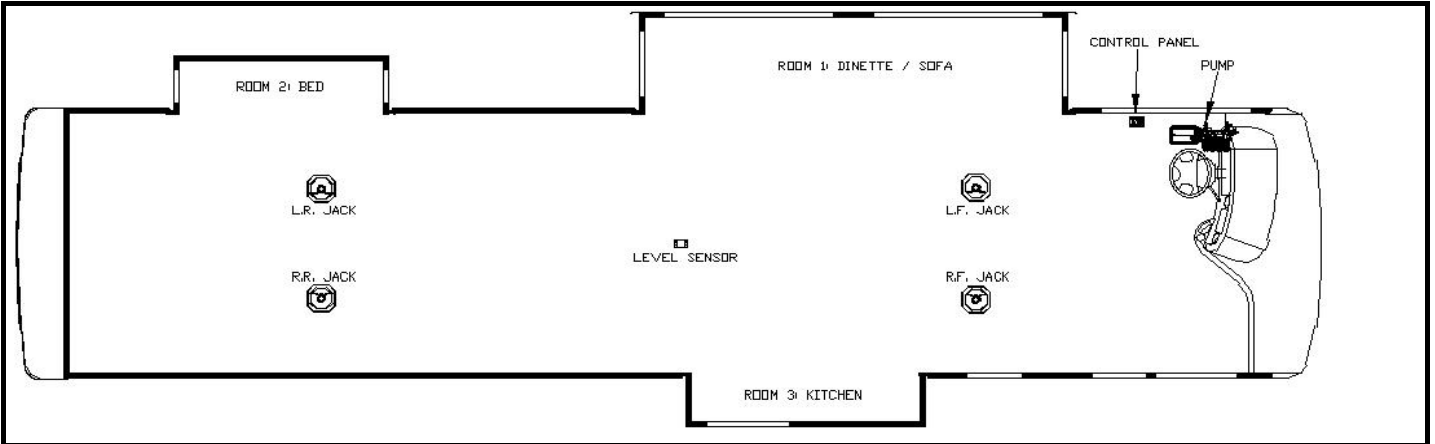

Notes:

- 1) Jacks mount to chassis brackets with the lowest holes of the jacks aligned with the lowest holes of the mounting brackets.
- 2) Level sensor attaches to bottom of structure; on lower hat section flanges or square tube.
- 3) Hydraulic hose terminations for room #1 & #3 require 90 degree swivel elbows.
- 4) Reference FM-3991 for a better visual of Room 1 hydraulic connections.

Item, Length	Description / Location	Qty	Color	Vendor PN	
Kit	(Items listed below)	1		8310	
Pump	7-Function, 3 Rooms & Jacks	1		7319	Measuring from inside of firewall, this is the end location of the hydraulic hoses where they attach to the slide mechanism.
Jack	17,000 lbs, 18" Stroke	4		7134	
Control Panel	Located to the left of the drivers seat	1		2057	
Level Sensor	Attached to bottom of structure	1		7196	
Sync Cylinder	Mounted	1		7351	
Hose, 126	Pump to Jack, Left Front	2	Brown	7246	
Hose, 364	Pump to Jack, Left Rear	2	Orange	7307	
Hose, 140	Pump to Jack, Right Front	2	White	7308	
Hose, 364	Pump to Jack, Right Rear	2	Yellow	7309	
Hose, 140	Pump to synchronizing manifold	2	Green	7311	
Hose w90, 170	Sync cylinder to front slide, Room 1	2	Green	2415	103 / Drivers side
Hose w90, 170	Sync cylinder to rear slide, Room 1	2	Green	2415	196 / Drivers side
	Pump to Room 1	N/A	Green		
Hose, 420	Pump to Room 2	2	Purple	7313	325 / Drivers Side
Hose w90, 200	Pump to Room 3	2	Red	7315	146 / Passenger Side
	Pump to Room 4	N/A			
	Pump to Generator Slide	N/A			N/A
Travel Clamp	(two per slide, except the bed slide)	4		HWH	N/A

Options

Revisions

36A Valencia
EQUALIZER JACKS (FULLY AUTOMATIC)
STANDARD ON THIS UNIT

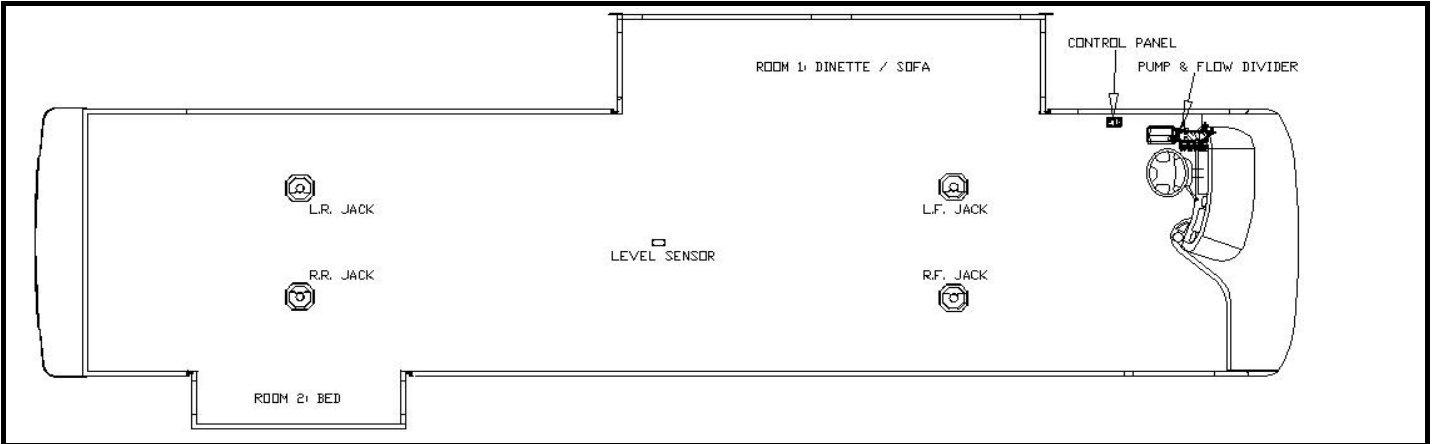

Notes:

- 1) Jacks mount to chassis brackets with the lowest holes of the jacks aligned with the lowest holes of the mounting brackets.
- 2) Level sensor attaches to bottom of structure; on lower hat section flanges or square tube.
- 3) Hydraulic hose terminations for room #1 require 90 degree swivel elbows.
- 4) Reference FM-3991 for a better visual of Room 1 hydraulic connections.

Item, Length	Description / Location	Qty	Color	Vendor PN	
Kit	(Items listed below)	1		8279	
Pump	6-Function, 2 Rooms & Jacks	1		7318	
Jack	17,000 lbs, 18" Stroke	4		7134	
Touch Pad	Located to the left of the drivers seat	1		2318	
Control Box	Attached to bottom of structure	1		2319	
Sync Cylinder	Mounted	1		7351	
Hose, 132	Pump to Jack, Left Front	2	Brown	2466	
Hose, 372	Pump to Jack, Left Rear	2	Orange	2481	
Hose, 144	Pump to Jack, Right Front	2	White	2467	
Hose, 372	Pump to Jack, Right Rear	2	Yellow	2481	
Hose, 144	Pump to synchronizing manifold	2	Green	2467	Mounts to bracket on structure
Hose w90, 168	Sync cylinder to front slide, Room 1	2	Green	2469	103 / Drivers side
Hose w90, 168	Sync cylinder to rear slide, Room 1	2	Green	2469	196 / Drivers side
	Pump to Room 1	N/A	Green		
Hose, 456	Pump to Room 2	2	Purple	2488	325 / Passenger Side
	Pump to Room 3		Gray		
	Pump to Room 4		Red		
	Pump to Generator Slide	N/A			N/A
Travel Clamp	(two per slide, except the bed slide)	2		HWH	N/A

Measuring from inside of firewall, this is the end location of the hydraulic hoses where they attach to the slide mechanism.

Options

Item, Length	Description / Location	Qty	Color	Vendor PN	

Revisions

1	ECN #3714, added the note on hose fittings for the 3" in floor slide (now 90 degree fittings)
2	ECN #3772, changed dinette slide hoses to mech 2, now 16" longer for routing
3	ECN #3845, flow divider is replaced by the synchronizing cylinder (all field units as well)

**32B KODIAK (19.5) TIRES
EQUALIZER JACKS (FULLY AUTOMATIC)
OPTIONAL ON THIS UNIT**

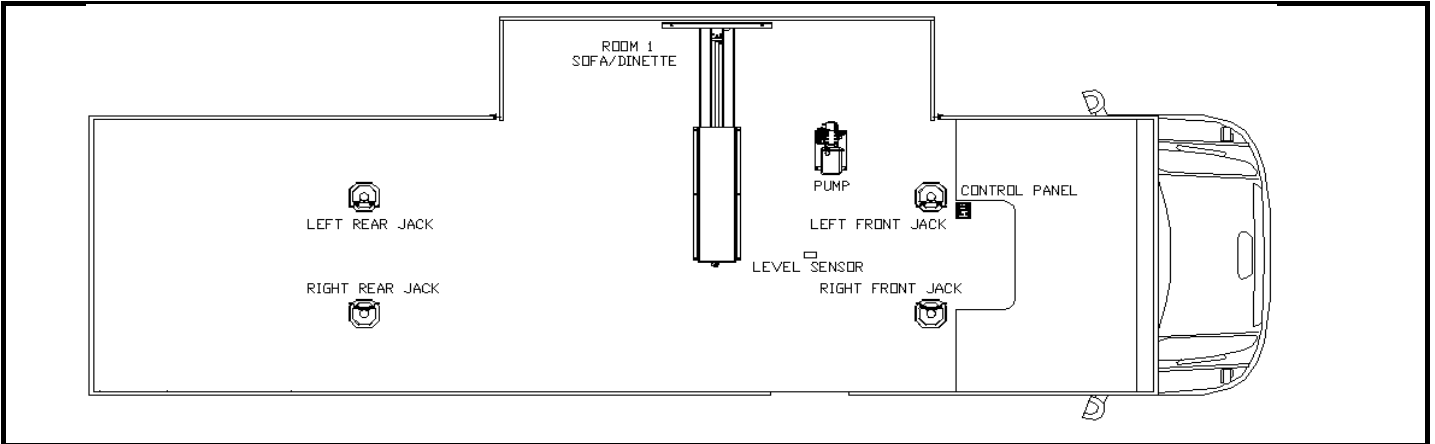

Notes:

1) Jacks mount 2nd hole from top to top mounting plate hole.

Item, Length	Description / Location	Qty	Color	Vendor PN	
Kit	(Items listed below)	1		8264	Measuring from back of cab floor, this is the end location of the hydraulic hoses where they attach to the slide mechanism.
Pump	5-Function, 1 Room, Jacks	1		7242	
Jack	12,000 lbs, 16" Stroke	4		7214	
Touch Pad	Located to the right of the drivers seat	1		2318	
Control Box	Attached to bottom of structure	1		2319	
Flow Divider	Mounted inside pump compartment	N/A		N/A	
Hose, 84	Pump to Jack, Left Front	2	Brown	2462	
Hose, 264	Pump to Jack, Left Rear	2	Orange	2476	
Hose, 108	Pump to Jack, Right Front	2	White	2464	
Hose, 276	Pump to Jack, Right Rear	2	Yellow	2477	
Hose, N/A	Pump to Flow Divider	N/A	TBD	N/A	N/A
Hose, N/A	Flow divider to front slide, Room 1	N/A	TBD	N/A	N/A
Hose, N/A	Flow divider to rear slide, Room 1	N/A	TBD	N/A	N/A
Hose, 84	Pump to Room 1	2	Green	2462	80 / Drivers Side
Hose, N/A	Pump to Room 2	N/A	Purple	N/A	N/A
Hose, N/A	Pump to Room 3	N/A	Gray	N/A	N/A
Hose, N/A	Pump to Room 4	N/A	Red	N/A	N/A
Hose, N/A	Pump to Generator Slide	N/A	TBD	N/A	N/A
Travel Clamp	Two per Slide	N/A		HWH	N/A
Options					
Revisions	Description		By	Date	
1	Made Jack, Control Panel, Level Sensor & hoses standard		JB	11/17/2005	

**32B KODIAK (19.5) TIRES
EQUALIZER JACKS (FULLY AUTOMATIC)
OPTIONAL ON THIS UNIT**

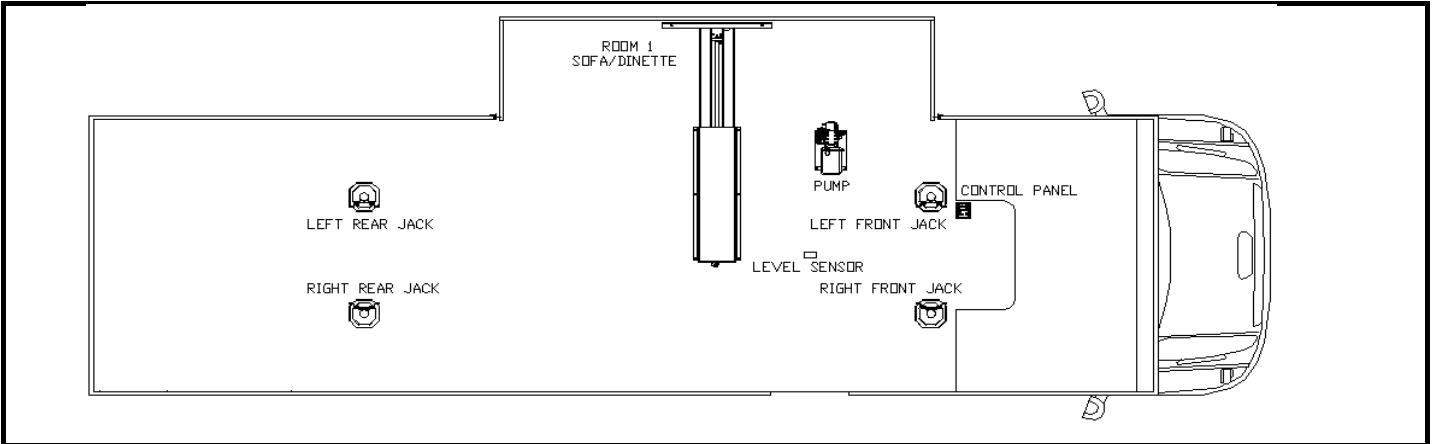

Notes:

1) Jacks mount 2nd hole from top to top mounting plate hole.

Item, Length	Description / Location	Qty	Color	Vendor PN	
Kit	(Items listed below)	1		8264	Measuring from back of cab floor, this is the end location of the hydraulic hoses where they attach to the slide mechanism.
Pump	5-Function, 1 Room, Jacks	1		7242	
Jack	12,000 lbs, 16" Stroke	4		7214	
Touch Pad	Located to the right of the drivers seat	1		2318	
Control Box	Attached to bottom of structure	1		2319	
Flow Divider	Mounted inside pump compartment	N/A		N/A	
Hose, 84	Pump to Jack, Left Front	2	Brown	2462	
Hose, 264	Pump to Jack, Left Rear	2	Orange	2476	
Hose, 108	Pump to Jack, Right Front	2	White	2464	
Hose, 276	Pump to Jack, Right Rear	2	Yellow	2477	
Hose, N/A	Pump to Flow Divider	N/A	TBD	N/A	N/A
Hose, N/A	Flow divider to front slide, Room 1	N/A	TBD	N/A	N/A
Hose, N/A	Flow divider to rear slide, Room 1	N/A	TBD	N/A	N/A
Hose, 84	Pump to Room 1	2	Green	2462	80 / Drivers Side
Hose, N/A	Pump to Room 2	N/A	Purple	N/A	N/A
Hose, N/A	Pump to Room 3	N/A	Gray	N/A	N/A
Hose, N/A	Pump to Room 4	N/A	Red	N/A	N/A
Hose, N/A	Pump to Generator Slide	N/A	TBD	N/A	N/A
Travel Clamp	Two per Slide	N/A		HWH	N/A
Options					
Revisions					
	Description		By	Date	
1	Made Jack, Control Panel, Level Sensor & hoses standard		JB	11/17/2005	

**35B MAGELLAN (22.5) TIRES
EQUALIZER JACKS (FULLY AUTOMATIC)
STANDARD ON THIS UNIT**

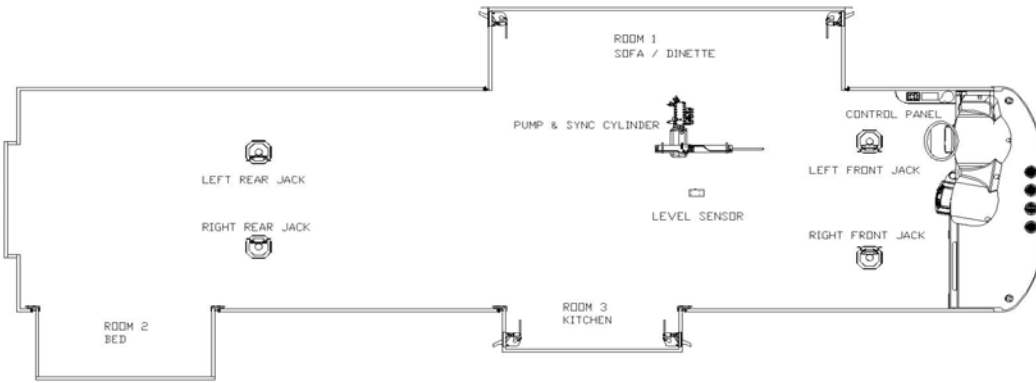

Notes:

1) Jacks mount in two different locations on bracket depending on tire size of chassis.

a) 19.5 Tires: Top hole in jack to top hole in bracket. Use 4 bolts in welded area of bracket.

b) 22.5 Tires: Top hole in jack to second hole in bracket. Use 6 bolts, 4 in welded area of bracket & 2 below welded area.

Item, Length	Description / Location	Qty	Color	Vendor PN		
Kit	(Items listed below)	1		8313	Measuring from inside of firewall, this is the end location of the hydraulic hoses where they attach to the slide mechanism.	
Pump	7-Function, 2 Rooms & Jacks	1		7301		
Jack	12,000 lbs, 16" Stroke	4		7214		
Control Panel	Located to the left of the drivers seat	1		2057		
Level Sensor	Attached to bottom of structure	1		7196		
Sync Cylinder	Mounted behind pump compartment	1		7351		
Hose, 140	Pump to Jack, Left Front	2	Brown	7294		
Hose, 264	Pump to Jack, Left Rear	2	Orange	7322		
Hose, 180	Pump to Jack, Right Front	2	White	7296		
Hose, 300	Pump to Jack, Right Rear	2	Yellow	7323		
Hose, 32	Pump to sync cylinder	2	Green	7298		Inside pump compartment
Hose, 110	Sync cylinder to front slide, Room 1	2	Green	2392		95 / Drivers Side
Hose, 110	Sync cylinder to rear slide, Room 1	2	Green	2392		166 / Drivers Side
Hose, N/A	Pump to Room 1	N/A	Green	N/A	N/A	
Hose, 420	Pump to Room 2	2	Purple	7313	350 / Passenger Side	
Hose w90, 110	Pump to Room 3	2	Gray	7299	160 / Passenger Side	
Hose, N/A	Pump to Room 4	N/A	Red	N/A	N/A	
Hose, N/A	Pump to Generator Slide	N/A		N/A	N/A	
Travel Clamp	Two per Slide	4		HWH	N/A	

Options

Item, Length	Description / Location	Qty	Color	Vendor PN	

1	Add this floorplan for MY2007 starting with the schedule released 04/24/06.
2	Change name from 36B to 35B still starting with the release of 04/24/06

**35B MAGELLAN (22.5) TIRES
EQUALIZER JACKS (FULLY AUTOMATIC)
STANDARD ON THIS UNIT**

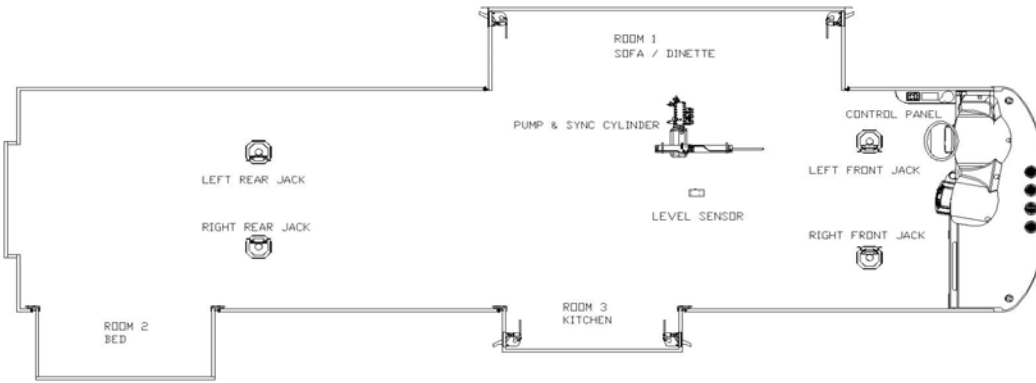

Notes:

1) Jacks mount in two different locations on bracket depending on tire size of chassis.

a) 19.5 Tires: Top hole in jack to top hole in bracket. Use 4 bolts in welded area of bracket.

b) 22.5 Tires: Top hole in jack to second hole in bracket. Use 6 bolts, 4 in welded area of bracket & 2 below welded area.

Item, Length	Description / Location	Qty	Color	Vendor PN	
Kit	(Items listed below)	1		8313	
Pump	7-Function, 2 Rooms & Jacks	1		7301	
Jack	12,000 lbs, 16" Stroke	4		7214	
Touch Pad	Located to the left of the drivers seat	1		2318	
Control Box	Attached to bottom of structure	1		2319	
Sync Cylinder	Mounted behind pump compartment	1		7387	
Hose, 144	Pump to Jack, Left Front	2	Brown	2467	
Hose, 264	Pump to Jack, Left Rear	2	Orange	2476	
Hose, 180	Pump to Jack, Right Front	2	White	2470	
Hose, 300	Pump to Jack, Right Rear	2	Yellow	2479	
Hose, 36	Pump to sync cylinder	2	Green	2458	Inside pump compartment
Hose, 108	Sync cylinder to front slide, Room 1	2	Green	2464	95 / Drivers Side
Hose, 108	Sync cylinder to rear slide, Room 1	2	Green	2464	166 / Drivers Side
Hose, N/A	Pump to Room 1	N/A	Green	N/A	N/A
Hose, 420	Pump to Room 2	2	Purple	2485	350 / Passenger Side
Hose w90, 108	Pump to Room 3	2	Gray	2464	160 / Passenger Side
Hose, N/A	Pump to Room 4	N/A	Red	N/A	N/A
Hose, N/A	Pump to Generator Slide	N/A	N/A	N/A	N/A
Travel Clamp	Two per Slide	4		HWH	N/A

Measuring from inside of firewall, this is the end location of the hydraulic hoses where they attach to the slide mechanism.

Options

Item, Length	Description / Location	Qty	Color	Vendor PN	

1 Add this floorplan for MY2007 starting with the schedule released 04/24/06.

2 Change name from 36B to 35B still starting with the release of 04/24/06

**39F Presidio
EQUALIZER JACKS (FULLY AUTOMATIC)
STANDARD ON THIS UNIT**

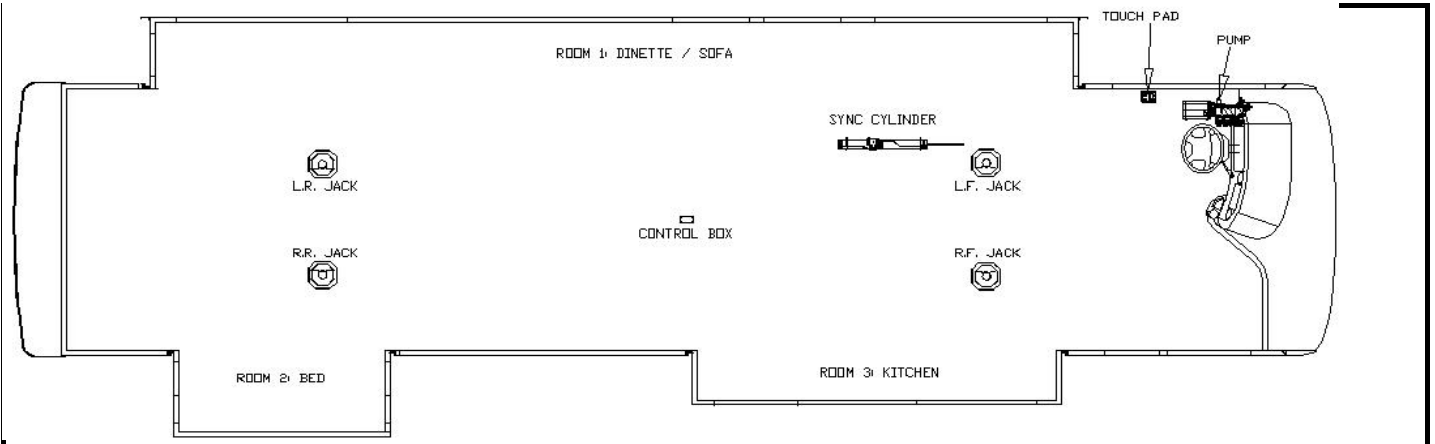

Notes:

- 1) Jacks mount to chassis brackets with the lowest holes of the jacks aligned with the lowest holes of the mounting brackets.
- 2) Level sensor attaches to bottom of structure; on the square tube the runs full length from axle to axle.
- 3) Hydraulic hose terminations for room #1 & #2 require 90 degree swivel elbows.
- 4) Room #1 will have a non-powered slide mechanism in center of room
- 5) Hoses marked w90 will have the 90 deg fitting shipped loose.

Item, Length	Description / Location	Qty	Color	Vendor PN	
Kit	(Items listed below)	1		8340	
Pump	8-Function, 4 Rooms & Jacks	1		7302	
Jack	17,000 lbs, 18" Stroke	4		7134	
Touch Pad	Located to the left of the drivers seat	1		2318	
Control Box	Attached to bottom of structure	1		2319	
Sync Cylinder	Mounted behind LP tank	1		7351	
Hose, 144	Pump to Jack, Left Front	2	Brown	2467	
Hose, 396	Pump to Jack, Left Rear	2	Orange	2483	
Hose, 144	Pump to Jack, Right Front	2	White	2467	
Hose, 396	Pump to Jack, Right Rear	2	Yellow	2483	
Hose, 144	Pump to synchronizing cylinder	2	Green	2467	Mounts to bracket on structure
Hose w90, 432	Sync cylinder to front slide, Room 1	2	Green	2486	103 / Drivers side
Hose w90, 432	Sync cylinder to rear slide, Room 1	2	Green	2486	350 / Drivers side
	Pump to Room 1	N/A	Green		
Hose w90, 228	Pump to Room 3	2	Purple	2474	146 / Passenger Side
Hose, 480	Pump to Room 2	2	Gray	2490	345 / Drivers Side
	Pump to Generator Slide	N/A			N/A
Travel Clamp	(two per slide, except the bed slide)	4		HWH	N/A

Measuring from inside of firewall, this is the end location of the hydraulic hoses where they attach to the slide mechanism.

Options

Revisions

1	UPDATE JPG
2	Updated per ECN #4237

39A Presidio
EQUALIZER JACKS (FULLY AUTOMATIC)
STANDARD ON THIS UNIT

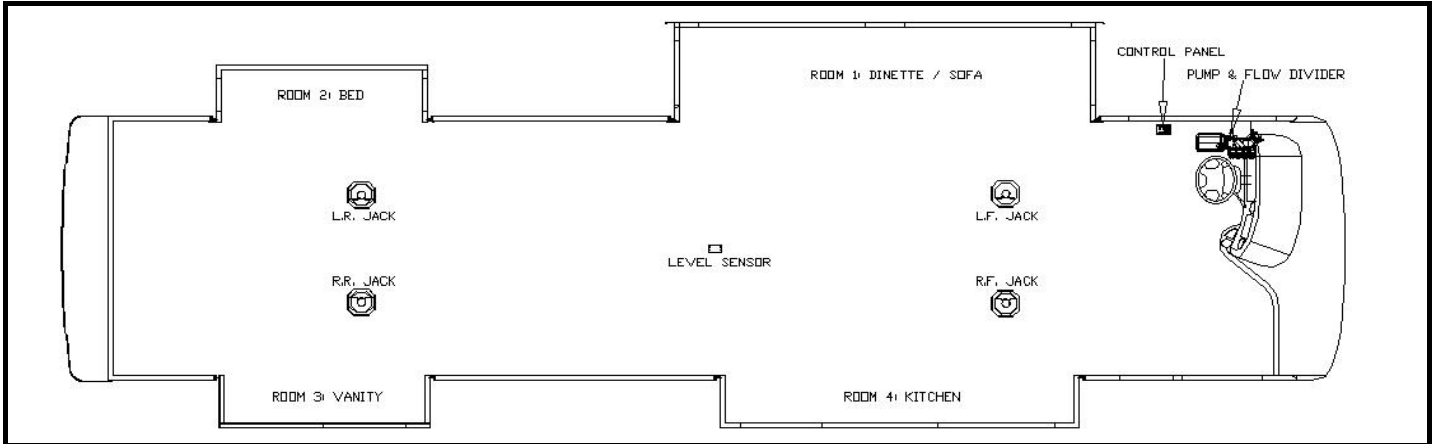

- Notes:**
- 1) Jacks mount to chassis brackets with the lowest holes of the jacks aligned with the lowest holes of the mounting brackets.
 - 2) Level sensor attaches to bottom of structure; on the square tube the runs full length from axle to axle.
 - 3) Hydraulic hose terminations for room #1, #3, & #4 require 90 degree swivel elbows.
 - 4) Reference FM-3991 for a better visual of Room 1 hydraulic connections.

Item, Length	Description / Location	Qty	Color	Vendor PN	
Kit	(Items listed below)	1		8294	
Pump	8-Function, 4 Rooms & Jacks	1		7302	
Jack	17,000 lbs, 18" Stroke	4		7134	
Touch Pad	Located to the left of the drivers seat	1		2318	
Control Box	Attached to bottom of structure	1		2319	
Sync Cylinder	Mounted behind LP tank	1		7351	
Hose, 144	Pump to Jack, Left Front	2	Brown	2467	
Hose, 396	Pump to Jack, Left Rear	2	Orange	2483	
Hose, 144	Pump to Jack, Right Front	2	White	2467	
Hose, 396	Pump to Jack, Right Rear	2	Yellow	2483	
Hose, 144	Pump to synchronizing cylinder	2	Green	2467	Mounts to bracket on structure
Hose w90, 168	Sync cylinder to front slide, Room 1	2	Green	2469	103 / Drivers side
Hose w90, 168	Sync cylinder to rear slide, Room 1	2	Green	2469	196 / Drivers side
	Pump to Room 1	N/A	Green		
Hose, 480	Pump to Room 2	2	Purple	2490	340 / Drivers Side
Hose w90, 432	Pump to Room 3	2	Gray	2486	365 / Passenger Side
Hose w90, 228	Pump to Room 4	2	Red	2474	146 / Passenger Side
	Pump to Generator Slide	N/A			N/A
Travel Clamp	(two per slide, except the bed slide)	6		HWH	N/A

Measuring from inside of firewall, this is the end location of the hydraulic hoses where they attach to the slide mechanism.

Options

Revisions

	Beginning with release of 1/23/06 and documented on ECN #3845

**39F Presidio
EQUALIZER JACKS (FULLY AUTOMATIC)
STANDARD ON THIS UNIT**

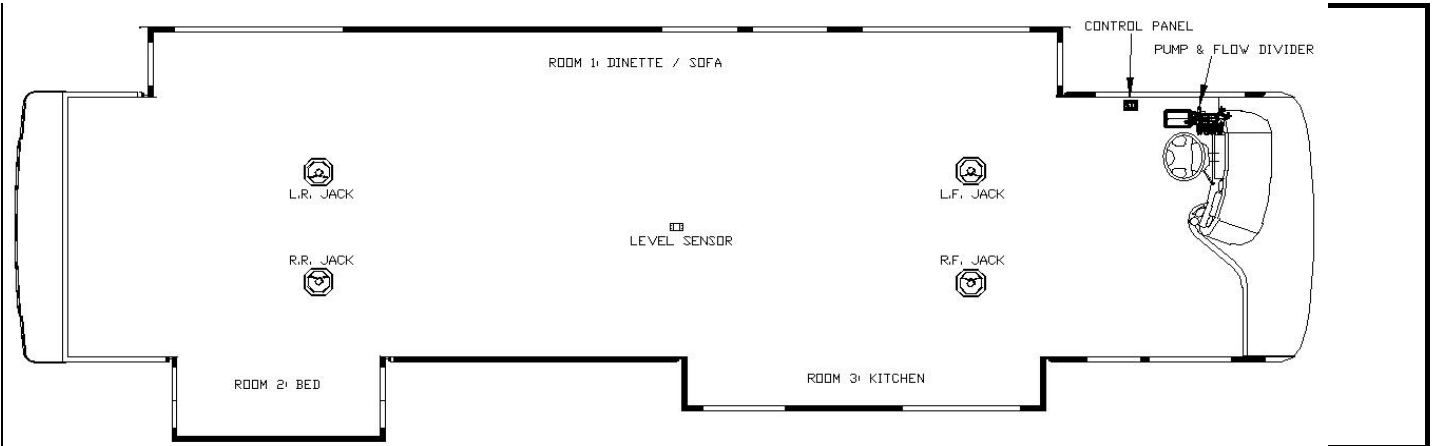

Notes:

- 1) Jacks mount to chassis brackets with the lowest holes of the jacks aligned with the lowest holes of the mounting brackets.
- 2) Level sensor attaches to bottom of structure; on the square tube the runs full length from axle to axle.
- 3) Hydraulic hose terminations for room #1 & #2 require 90 degree swivel elbows.
- 4) Room #1 will have a non-powered slide mechanism in center of room
- 5) Hoses marked w90 will have the 90 deg fitting shipped loose.

Item, Length	Description / Location	Qty	Color	Vendor PN	
Kit	(Items listed below)	1		8340	
Pump	8-Function, 4 Rooms & Jacks	1		7302	Measuring from inside of firewall, this is the end location of the hydraulic hoses where they attach to the slide mechanism.
Jack	17,000 lbs, 18" Stroke	4		7134	
Touch Pad	Located to the left of the drivers seat	1		2318	
Control Box	Attached to bottom of structure	1		2319	
Sync Cylinder	Mounted behind LP tank	1		7351	
Hose, 144	Pump to Jack, Left Front	2	Brown	2467	
Hose, 396	Pump to Jack, Left Rear	2	Orange	2483	
Hose, 144	Pump to Jack, Right Front	2	White	2467	
Hose, 396	Pump to Jack, Right Rear	2	Yellow	2483	
Hose, 144	Pump to synchronizing cylinder	2	Green	2467	
Hose w90, 168	Sync cylinder to front slide, Room 1	2	Green	2469	103 / Drivers side
Hose w90, 432	Sync cylinder to rear slide, Room 1	2	Green	2486	350 / Drivers side
	Pump to Room 1	N/A	Green		
Hose w90, 228	Pump to Room 3	2	Purple	2474	146 / Passenger Side
Hose, 480	Pump to Room 2	2	Gray	2490	345 / Drivers Side
	Pump to Generator Slide	N/A			N/A
Travel Clamp	(two per slide, except the bed slide)	4		HWH	N/A

Options

Revisions

40B Mandalay
EQUALIZER JACKS (FULLY AUTOMATIC)
STANDARD ON THIS UNIT

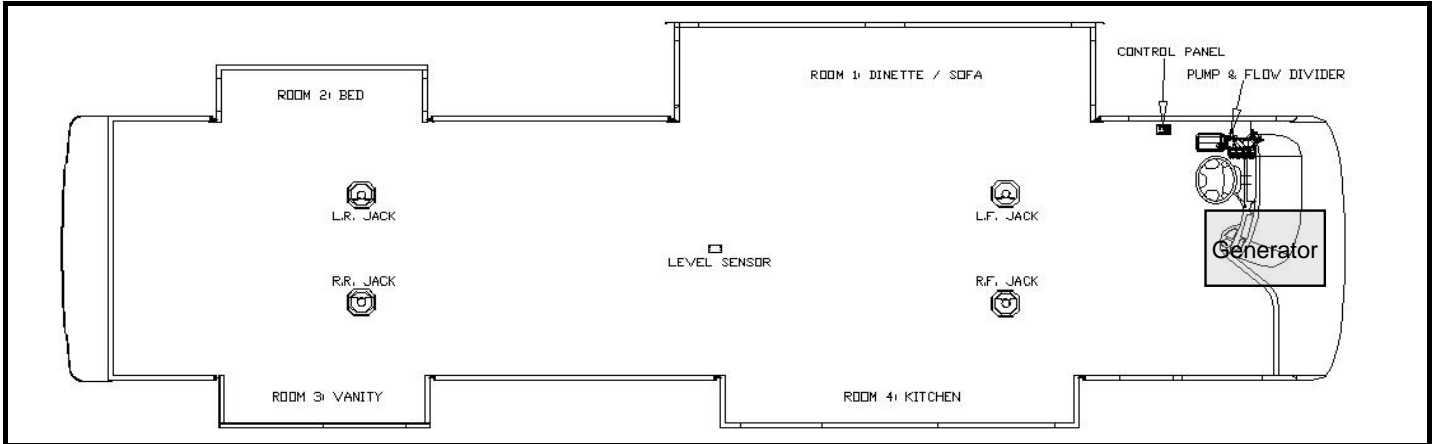

Notes:

- 1) Jacks mount to chassis brackets providing 8-9 inches of ground clearance with the air bags dumped.
- 2) Level sensor attaches to bottom of structure; on lower hat section flanges or square tube.
- 3) Hydraulic hose terminations for room #1, #3, & #4 require 90 degree swivel elbows.

Item, Length	Description / Location	Qty	Color	Vendor PN		
Kit	(Items listed below)	1		?	Measuring from inside of firewall, this is the end location of the hydraulic hoses where they attach to the slide mechanism.	
Pump	9-Function, 4 Rooms, & Jacks	1		?		
Jack	17,000 lbs, 18" Stroke	4		7134		
Touch Pad	Located to the left of the drivers seat	1		2318		
Control Box	Attached to bottom of structure	1		2319		
Sync Cylinder	Mounted behind LP tank	1		7351		
Hose, 132	Pump to Jack, Left Front	2	Brown	2466		
Hose, 396	Pump to Jack, Left Rear	2	Orange	2483		
Hose, 144	Pump to Jack, Right Front	2	White	2467		
Hose, 396	Pump to Jack, Right Rear	2	Yellow	2483		
Hose, 144	Pump to synchronizing cylinder	2	Green	2467		
Hose w90, 168	Sync cylinder to front slide, Room 1	1	Green	2469		99 / Drivers side
Hose w90, 168	Sync cylinder to rear slide, Room 1	1	Green	2469		187 / Drivers side
	Pump to Room 1	N/A	Green			
Hose, 504	Pump to Room 2	2	Purple	?	357 / Drivers Side	
Hose w90, 456	Pump to Room 3	2	Gray	2488	389 / Passenger Side	
Hose w90, 204	Pump to Room 4	2	Red	2472	146 / Passenger Side	
Hose, 60	Pump to Generator Slide	2		2460	Inside generator tray	
Travel Clamp	(two per slide, except the bed slide)	6		HWH	N/A	

Options

Revisions

**32R WINDSPORT (22.5) TIRES
EQUALIZER JACKS (FULLY AUTOMATIC)
STANDARD ON THIS UNIT**

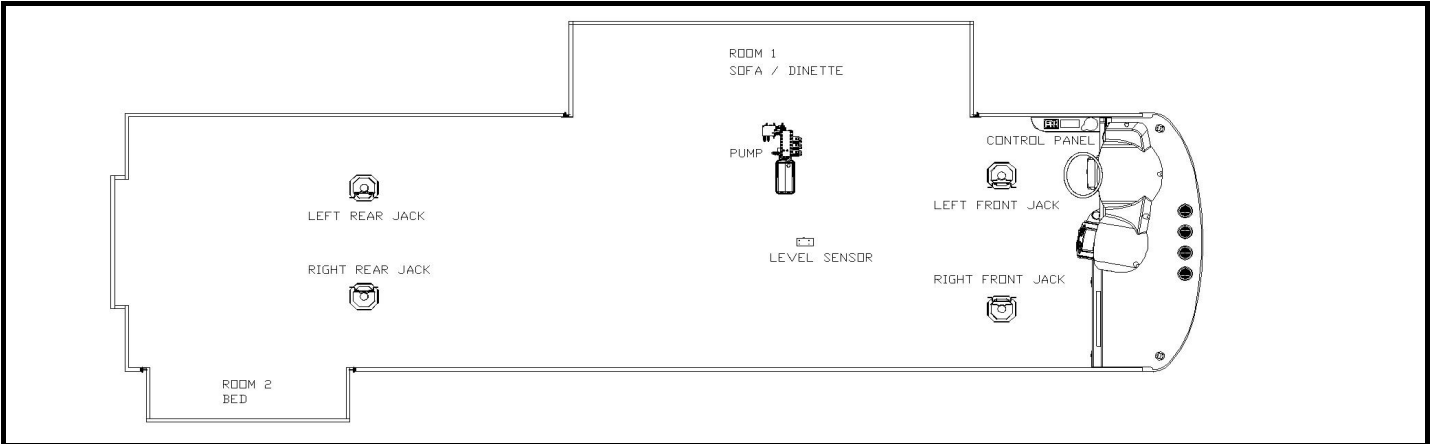

Notes:

- 1) Jacks mount in two different locations on bracket depending on tire size of chassis.
 - a) 19.5 Tires: Top hole in jack to top hole in bracket. Use 4 bolts in welded area of bracket.
 - b) 22.5 Tires: Top hole in jack to second hole in bracket. Use 6 bolts, 4 in welded area of bracket & 2 below welded area.

Item, Length	Description / Location	Qty	Color	Vendor PN	
Kit	(Items listed below)	1		8308	Measuring from inside of firewall, this is the end location of the hydraulic hoses where they attach to the slide mechanism.
Pump	6-Function, 2 Rooms & Jacks	1		7243	
Jack	12,000 lbs, 16" Stroke	4		7214	
Control Panel	Located to the left of the drivers seat	1		2057	
Level Sensor	Attached to bottom of structure	1		7196	
Sync Cylinder	Mounted behind pump compartment	N/A		N/A	
Hose, 140	Pump to Jack, Left Front	2	Brown	7294	
Hose, 240	Pump to Jack, Left Rear	2	Orange	7295	
Hose, 180	Pump to Jack, Right Front	2	White	7296	
Hose, 280	Pump to Jack, Right Rear	2	Yellow	7297	
Hose, N/A	Pump to sync cylinder	N/A	Green	N/A	Inside pump compartment
Hose, N/A	Sync cylinder to front slide, Room 1	N/A	Green	N/A	N/A
Hose, N/A	Sync cylinder to rear slide, Room 1	N/A	Green	N/A	N/A
Hose, 32	Pump to Room 1	2	Green	7298	127 / Drivers Side
Hose, 364	Pump to Room 2	2	Purple	7300	310 / Passenger Side
Hose, N/A	Pump to Room 3	N/A	Gray	N/A	N/A
Hose, N/A	Pump to Room 4	N/A	Red	N/A	N/A
Hose, N/A	Pump to Generator Slide	N/A	N/A	N/A	N/A
Travel Clamp	Two per Slide	N/A		HWH	N/A

Options

Revisions

1	New chart for Windsport for MY2007 due to Faux Flat on Rm 1, starting with the schedule released 04/24/06.

**32R WINDSPORT (22.5) TIRES
EQUALIZER JACKS (FULLY AUTOMATIC)
STANDARD ON THIS UNIT**

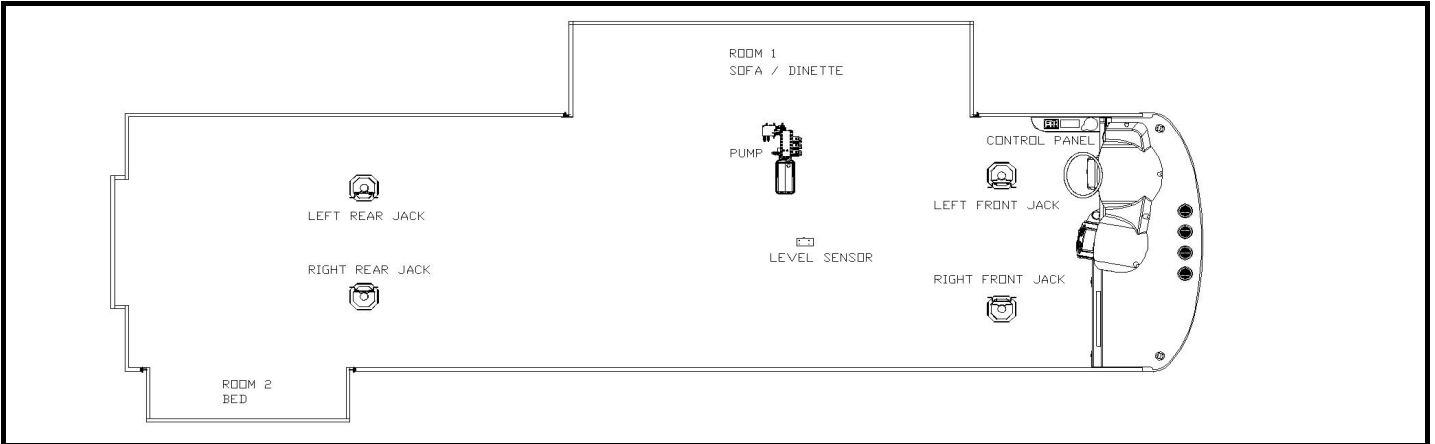

Notes:

- 1) Jacks mount in two different locations on bracket depending on tire size of chassis.
 - a) 19.5 Tires: Top hole in jack to top hole in bracket. Use 4 bolts in welded area of bracket.
 - b) 22.5 Tires: Top hole in jack to second hole in bracket. Use 6 bolts, 4 in welded area of bracket & 2 below welded area.

Item, Length	Description / Location	Qty	Color	Vendor PN		
Kit	(Items listed below)	1		8308	Measuring from inside of firewall, this is the end location of the hydraulic hoses where they attach to the slide mechanism.	
Pump	6-Function, 2 Rooms & Jacks	1		7243		
Jack	12,000 lbs, 16" Stroke	4		7214		
Touch Pad	Located to the left of the drivers seat	1		2318		
Control Box	Attached to bottom of structure	1		2319		
Sync Cylinder	Mounted behind pump compartment	N/A		N/A		
Hose, 144	Pump to Jack, Left Front	2	Brown	2467		
Hose, 240	Pump to Jack, Left Rear	2	Orange	2475		
Hose, 180	Pump to Jack, Right Front	2	White	2470		
Hose, 288	Pump to Jack, Right Rear	2	Yellow	2478		
Hose, N/A	Pump to sync cylinder	N/A	Green	N/A		Inside pump compartment
Hose, N/A	Sync cylinder to front slide, Room 1	N/A	Green	N/A		N/A
Hose, N/A	Sync cylinder to rear slide, Room 1	N/A	Green	N/A		N/A
Hose, 36	Pump to Room 1	2	Green	2458		127 / Drivers Side
Hose, 372	Pump to Room 2	2	Purple	2481	310 / Passenger Side	
Hose, N/A	Pump to Room 3	N/A	Gray	N/A	N/A	
Hose, N/A	Pump to Room 4	N/A	Red	N/A	N/A	
Hose, N/A	Pump to Generator Slide	N/A	N/A	N/A	N/A	
Travel Clamp	Two per Slide	N/A		HWH	N/A	

Options

Revisions

1	New chart for Windsport for MY2007 due to Faux Flat on Rm 1, starting with the schedule released 04/24/06.

39D FUN MOVER
EQUALIZER JACKS (FULLY AUTOMATIC)
OPTIONAL ON THIS UNIT

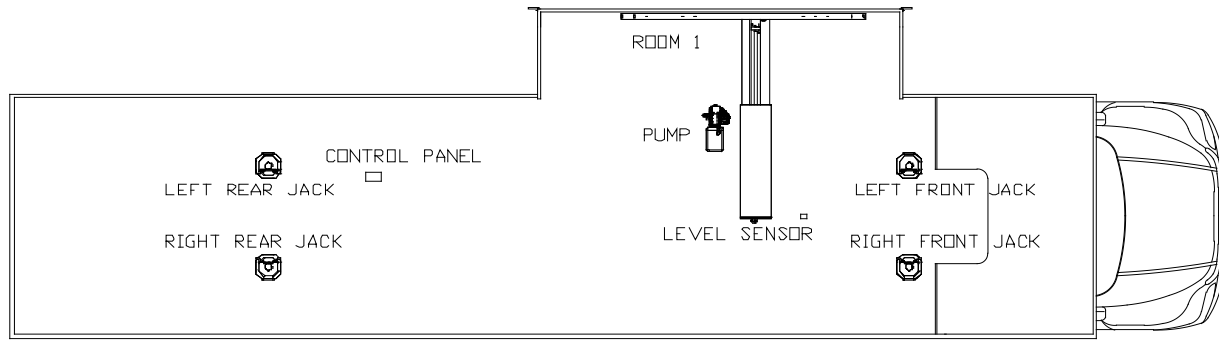

Notes:

1) Jacks mount 2nd hole from top to top mounting plate hole.

Item, Length	Description / Location	Qty	Color	Vendor PN	Measuring from back of cab floor, this is the end location of the hydraulic hoses where they attach to the slide mechanism.
Kit	(Items listed below)	1		8250	
Pump	5-Function, 1 Room, Jacks	1		7242	
Flow Divider	Mounted inside pump compartment	N/A		N/A	
Hose, N/A	Pump to Flow Divider	N/A	TBD	N/A	N/A
Hose, N/A	Flow divider to front slide, Room 1	N/A	TBD	N/A	N/A
Hose, N/A	Flow divider to rear slide, Room 1	N/A	TBD	N/A	N/A
Hose, 84	Pump to Room 1	2	Green	2462	73 / Drivers Side
Hose, N/A	Pump to Room 2	N/A	Purple	N/A	N/A
Hose, N/A	Pump to Room 3	N/A	Gray	N/A	N/A
Hose, N/A	Pump to Room 4	N/A	Red	N/A	N/A
Hose, N/A	Pump to Generator Slide	N/A	TBD	N/A	N/A
Travel Clamp	Two per Slide	N/A		HWH	N/A
Options					
Kit	(Items listed below)	1		8253	
Jack	12,000 lbs, 16" Stroke	4		7214	
Touch Pad	Located to the right of the drivers seat	1		2318	
Control Box	Attached to bottom of structure	1		2319	
Hose, 132	Pump to Jack, Left Front	2	Brown	2466	
Hose, 264	Pump to Jack, Left Rear	2	Orange	2476	
Hose, 168	Pump to Jack, Right Front	2	White	2469	
Hose, 276	Pump to Jack, Right Rear	2	Yellow	2477	
Revisions					

42D FUN MOVER
EQUALIZER JACKS (FULLY AUTOMATIC)
OPTIONAL ON THIS UNIT

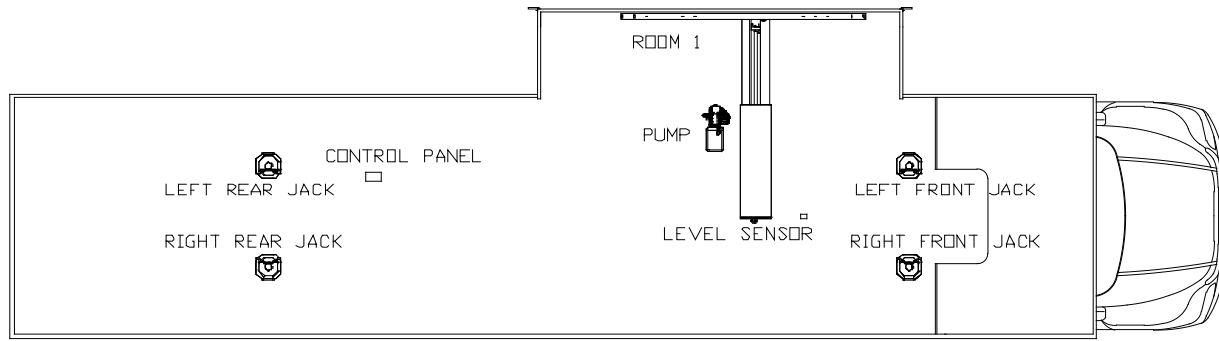

Notes:

1) Jacks mount 2nd hole from top to top mounting plate hole.

Item, Length	Description / Location	Qty	Color	Vendor PN	Measuring from back of cab floor, this is the end location of the hydraulic hoses where they attach to the slide mechanism.
Kit	(Items listed below)	1		8250	
Pump	5-Function, 1 Room, Jacks	1		7242	
Flow Divider	Mounted inside pump compartment	N/A		N/A	
Hose, N/A	Pump to Flow Divider	N/A	TBD	N/A	N/A
Hose, N/A	Flow divider to front slide, Room 1	N/A	TBD	N/A	N/A
Hose, N/A	Flow divider to rear slide, Room 1	N/A	TBD	N/A	N/A
Hose, 84	Pump to Room 1	2	Green	2462	73 / Drivers Side
Hose, N/A	Pump to Room 2	N/A	Purple	N/A	N/A
Hose, N/A	Pump to Room 3	N/A	Gray	N/A	N/A
Hose, N/A	Pump to Room 4	N/A	Red	N/A	N/A
Hose, N/A	Pump to Generator Slide	N/A	TBD	N/A	N/A
Travel Clamp	Two per Slide	N/A		HWH	N/A
Options					
Kit	(Items listed below)	1		8253	
Jack	12,000 lbs, 16" Stroke	4		7214	
Touch Pad	Located to the right of the drivers seat	1		2318	
Control Box	Attached to bottom of structure	1		2319	
Hose, 132	Pump to Jack, Left Front	2	Brown	2466	
Hose, 264	Pump to Jack, Left Rear	2	Orange	2476	
Hose, 168	Pump to Jack, Right Front	2	White	2469	
Hose, 276	Pump to Jack, Right Rear	2	Yellow	2477	
Revisions					

**31D HURRICANE/WINDSPORT (19.5) TIRES
EQUALIZER JACKS (FULLY AUTOMATIC)
OPTIONAL ON THIS UNIT**

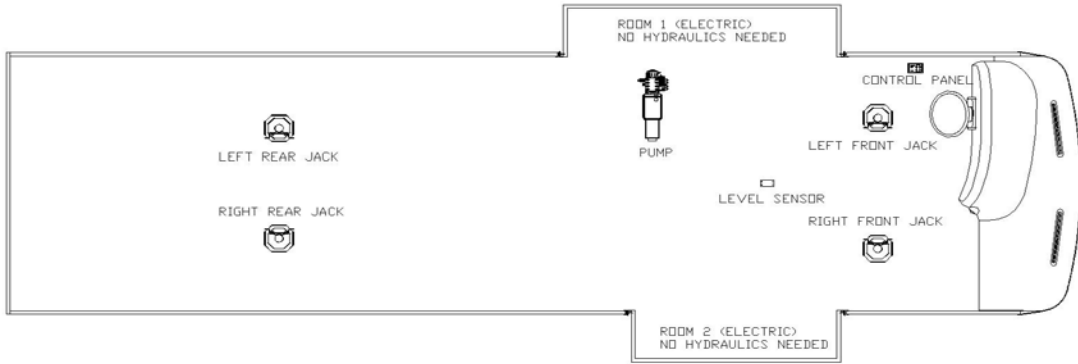

Notes:

1) Jacks mount in two different locations on bracket depending on tire size of chassis.

a) 19.5 Tires: Top hole in jack to top hole in bracket. Use 4 bolts in welded area of bracket.

b) 22.5 Tires: Top hole in jack to second hole in bracket. Use 6 bolts, 4 in welded area of bracket & 2 below welded area.

Item, Length	Description / Location	Qty	Color	Vendor PN		
Kit	(Items listed below)	1		8252	Measuring from inside of firewall, this is the end location of the hydraulic hoses where they attach to the slide mechanism.	
Pump	4-Function, Jacks	1		7239BR		
Jack	12,000 lbs, 16" Stroke	4		7214		
Touch Pad	Located to the left of the drivers seat	1		2318		
Control Box	Attached to bottom of structure	1		2730		
Flow Divider	Mounted inside pump compartment	N/A		N/A		
Hose, 132	Pump to Jack, Left Front	2	Brown	2466		
Hose, 216	Pump to Jack, Left Rear	2	Orange	2473		
Hose, 180	Pump to Jack, Right Front	2	White	2470		
Hose, 264	Pump to Jack, Right Rear	2	Yellow	2476		
Hose, N/A	Pump to Flow Divider	N/A	Green	N/A		N/A
Hose, N/A	Flow divider to front slide, Room 1	N/A	Green	N/A		N/A
Hose, N/A	Flow divider to rear slide, Room 1	N/A	Green	N/A		N/A
Hose, N/A	Pump to Room 1	N/A	Green	N/A		N/A
Hose, N/A	Pump to Room 2	N/A	Purple	N/A		N/A
Hose, N/A	Pump to Room 3	N/A	Gray	N/A		N/A
Hose, N/A	Pump to Room 4	N/A	Red	N/A	N/A	
Hose, N/A	Pump to Generator Slide	N/A		N/A	N/A	
Travel Clamp	Two per Slide	N/A		HWH	N/A	

Options

Revisions

1	Add Windport to Title of this chart for MY2007.

**32E HURRICANE/WINDSPORT (19.5) TIRES
EQUALIZER JACKS (FULLY AUTOMATIC)
OPTIONAL ON THIS UNIT**

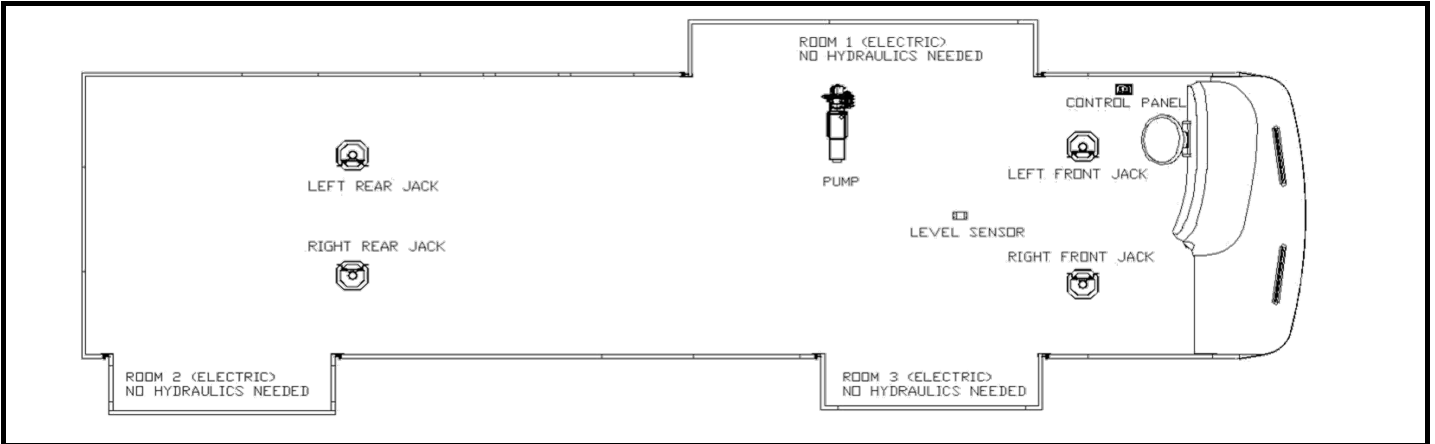

Notes:

1) Jacks mount in two different locations on bracket depending on tire size of chassis.

a) 19.5 Tires: Top hole in jack to top hole in bracket. Use 4 bolts in welded area of bracket.

b) 22.5 Tires: Top hole in jack to second hole in bracket. Use 6 bolts, 4 in welded area of bracket & 2 below welded area.

Item, Length	Description / Location	Qty	Color	Vendor PN		
Kit	(Items listed below)	1		8252		
Pump	4-Function, Jacks	1		7239BR		
Jack	12,000 lbs, 16" Stroke	4		7214		
Touch Pad	Located to the left of the drivers seat	1		2318		
Control Box	Attached to bottom of structure	1		2730		
Flow Divider	Mounted inside pump compartment	N/A		N/A		
Hose, 132	Pump to Jack, Left Front	2	Brown	2466	Measuring from inside of firewall, this is the end location of the hydraulic hoses where they attach to the slide mechanism.	
Hose, 216	Pump to Jack, Left Rear	2	Orange	2473		
Hose, 180	Pump to Jack, Right Front	2	White	2470		
Hose, 264	Pump to Jack, Right Rear	2	Yellow	2476		
Hose, N/A	Pump to Flow Divider	N/A	Green	N/A		N/A
Hose, N/A	Flow divider to front slide, Room 1	N/A	Green	N/A		N/A
Hose, N/A	Flow divider to rear slide, Room 1	N/A	Green	N/A		N/A
Hose, N/A	Pump to Room 1	N/A	Green	N/A		N/A
Hose, N/A	Pump to Room 2	N/A	Purple	N/A		N/A
Hose, N/A	Pump to Room 3	N/A	Gray	N/A		N/A
Hose, N/A	Pump to Room 4	N/A	Red	N/A	N/A	
Hose, N/A	Pump to Generator Slide	N/A		N/A	N/A	
Travel Clamp	Two per Slide	N/A		HWH	N/A	

Options

Revisions

**32R HURRICANE (19.5) TIRES
EQUALIZER JACKS (FULLY AUTOMATIC)
STANDARD ON THIS UNIT**

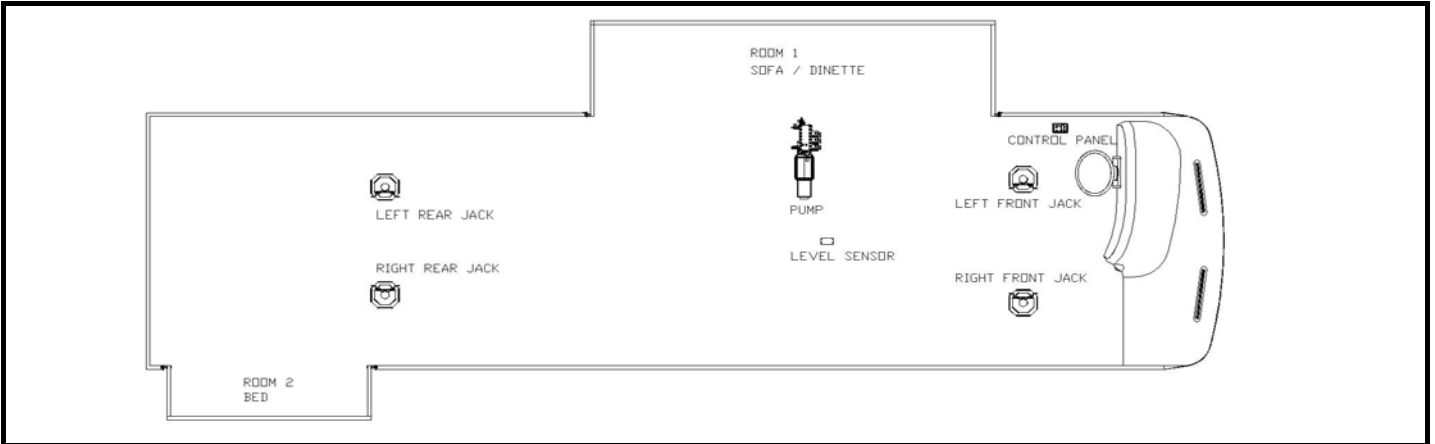

Notes:

1) Jacks mount in two different locations on bracket depending on tire size of chassis.

a) 19.5 Tires: Top hole in jack to top hole in bracket. Use 4 bolts in welded area of bracket.

b) 22.5 Tires: Top hole in jack to second hole in bracket. Use 6 bolts, 4 in welded area of bracket & 2 below welded area.

Item, Length	Description / Location	Qty	Color	Vendor PN		
Kit	(Items listed below)	1		8254	Measuring from inside of firewall, this is the end location of the hydraulic hoses where they attach to the slide mechanism.	
Pump	6-Function, 2 Rooms, Jacks	1		7243BR		
Jack	12,000 lbs, 16" Stroke	4		7214		
Touch Pad	Located to the left of the drivers seat	1		2318		
Control Box	Attached to bottom of structure	1		2730		
Flow Divider	Mounted inside pump compartment	N/A		N/A		
Hose, 132	Pump to Jack, Left Front	2	Brown	2466		
Hose, 216	Pump to Jack, Left Rear	2	Orange	2473		
Hose, 180	Pump to Jack, Right Front	2	White	2470		
Hose, 228	Pump to Jack, Right Rear	2	Yellow	2474		
Hose, N/A	Pump to Flow Divider	N/A	Green	N/A		N/A
Hose, N/A	Flow divider to front slide, Room 1	N/A	Green	N/A		N/A
Hose, N/A	Flow divider to rear slide, Room 1	N/A	Green	N/A		N/A
Hose, 36	Pump to Room 1	2	Green	2458		127 / Drivers Side
Hose, 372	Pump to Room 2	2	Purple	2481		305 / Passenger Side
Hose, N/A	Pump to Room 3	N/A	Gray	N/A	N/A	
Hose, N/A	Pump to Room 4	N/A	Red	N/A	N/A	
Hose, N/A	Pump to Generator Slide	N/A		N/A	N/A	
Travel Clamp	Two per Slide	N/A		HWH	N/A	

Options

Revisions

**33H HURRICANE (19.5) TIRES
EQUALIZER JACKS (FULLY AUTOMATIC)
STANDARD ON THIS UNIT**

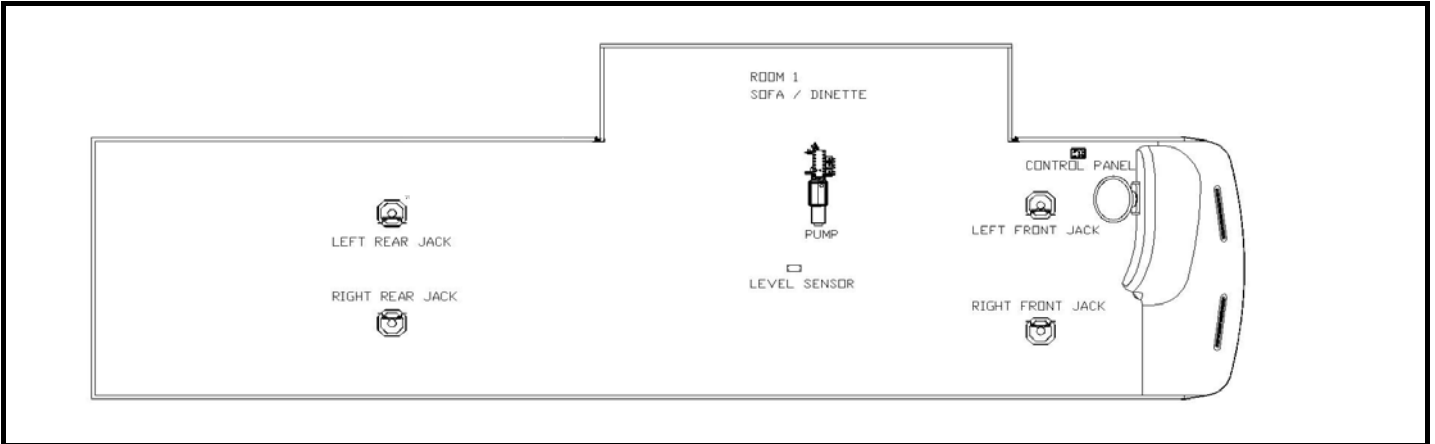

Notes:

- 1) Jacks mount in two different locations on bracket depending on tire size of chassis.
 - a) 19.5 Tires: Top hole in jack to top hole in bracket. Use 4 bolts in welded area of bracket.
 - b) 22.5 Tires: Top hole in jack to second hole in bracket. Use 6 bolts, 4 in welded area of bracket & 2 below welded area.

Item, Length	Description / Location	Qty	Color	Vendor PN		
Kit	(Items listed below)	1		8270	Measuring from inside of firewall, this is the end location of the hydraulic hoses where they attach to the slide mechanism.	
Pump	5-Function, 1 Room, Jacks	1		7242BR		
Jack	12,000 lbs, 16" Stroke	4		7214		
Touch Pad	Located to the left of the drivers seat	1		2318		
Control Box	Attached to bottom of structure	1		2730		
Flow Divider	Mounted inside pump compartment	N/A		N/A		
Hose, 132	Pump to Jack, Left Front	2	Brown	2466		
Hose, 216	Pump to Jack, Left Rear	2	Orange	2473		
Hose, 180	Pump to Jack, Right Front	2	White	2470		
Hose, 264	Pump to Jack, Right Rear	2	Yellow	2476		
Hose, N/A	Pump to Flow Divider	N/A	Green	N/A		N/A
Hose, N/A	Flow divider to front slide, Room 1	N/A	Green	N/A		N/A
Hose, N/A	Flow divider to rear slide, Room 1	N/A	Green	N/A		N/A
Hose, 36	Pump to Room 1	2	Green	2458		127 / Drivers Side
Hose, N/A	Pump to Room 2	N/A	Purple	N/A		N/A
Hose, N/A	Pump to Room 3	N/A	Gray	N/A	N/A	
Hose, N/A	Pump to Room 4	N/A	Red	N/A	N/A	
Hose, N/A	Pump to Generator Slide	N/A		N/A	N/A	
Travel Clamp	Two per Slide	N/A		HWH	N/A	

Options					

Revisions					

**34B/34S HURRICANE (19.5) TIRES
EQUALIZER JACKS (FULLY AUTOMATIC)
STANDARD ON THIS UNIT**

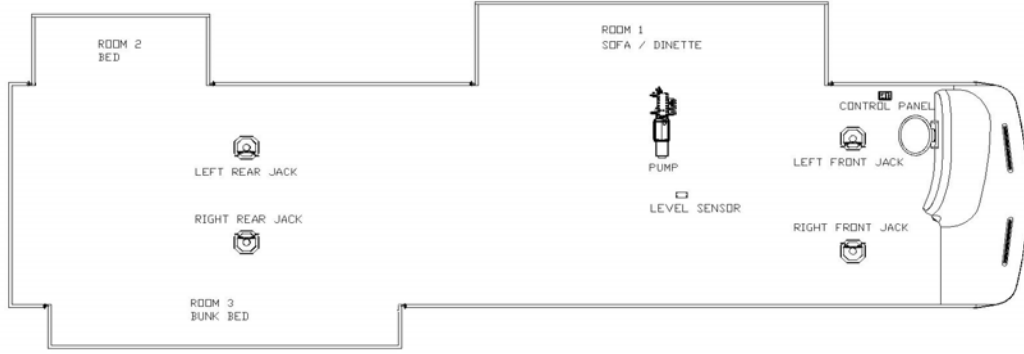

Notes:

1) Jacks mount in two different locations on bracket depending on tire size of chassis.

a) 19.5 Tires: Top hole in jack to top hole in bracket. Use 4 bolts in welded area of bracket.

b) 22.5 Tires: Top hole in jack to second hole in bracket. Use 6 bolts, 4 in welded area of bracket & 2 below welded area.

Item, Length	Description / Location	Qty	Color	Vendor PN		
Kit	(Items listed below)	1		8323	Measuring from inside of firewall, this is the end location of the hydraulic hoses where they attach to the slide mechanism.	
Pump	7-Function, 3 Rooms, Jacks	1		7301BR		
Jack	12,000 lbs, 16" Stroke	4		7214		
Touch Pad	Located to the left of the drivers seat	1		2318		
Control Box	Attached to bottom of structure	1		2730		
Flow Divider	Mounted inside pump compartment	N/A		N/A		
Hose, 132	Pump to Jack, Left Front	2	Brown	2466		
Hose, 240	Pump to Jack, Left Rear	2	Orange	2475		
Hose, 168	Pump to Jack, Right Front	2	White	2469		
Hose, 264	Pump to Jack, Right Rear	2	Yellow	2476		
Hose, N/A	Pump to Flow Divider	N/A	Green	N/A		N/A
Hose, N/A	Flow divider to front slide, Room 1	N/A	Green	N/A		N/A
Hose, N/A	Flow divider to rear slide, Room 1	N/A	Green	N/A		N/A
Hose, 36	Pump to Room 1	2	Green	2458		127 / Drivers Side
Hose, 372	Pump to Room 2	2	Purple	2481	341 / Drivers Side	
Hose w90, 372	Pump to Room 3	2	Gray	2481	300 / Passenger Side	
Hose, N/A	Pump to Room 4	N/A	Red	N/A	N/A	
Hose, N/A	Pump to Generator Slide	N/A	N/A	N/A	N/A	
Travel Clamp	Two per Slide	N/A		HWH	N/A	

Options

Revisions

9/1/2006	Add 34S to 34B chart				

**34N HURRICANE (19.5) TIRES
EQUALIZER JACKS (FULLY AUTOMATIC)
STANDARD ON THIS UNIT**

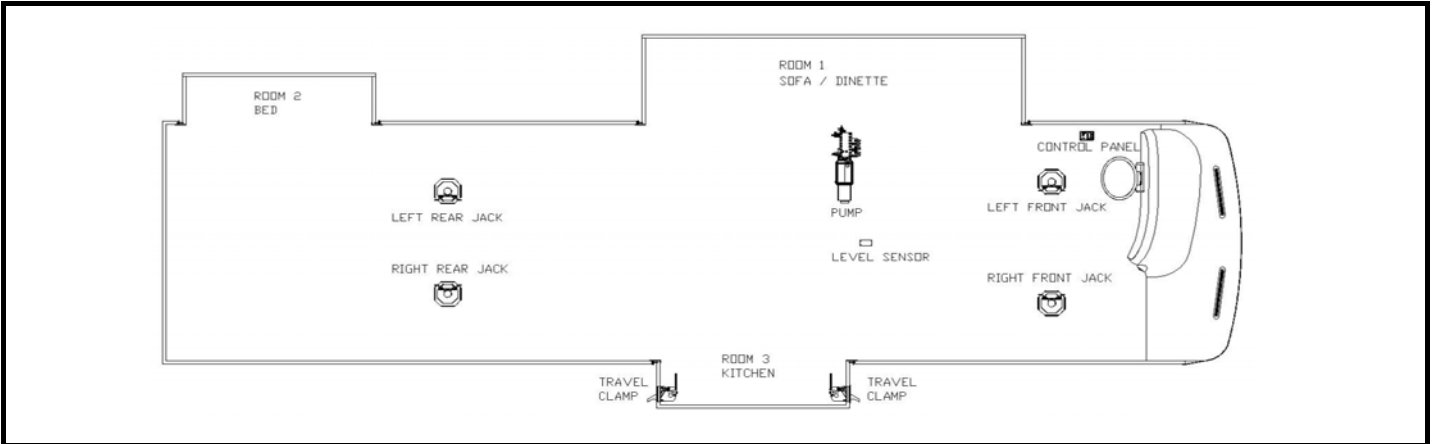

Notes:

- 1) Jacks mount in two different locations on bracket depending on tire size of chassis.
 - a) 19.5 Tires: Top hole in jack to top hole in bracket. Use 4 bolts in welded area of bracket.
 - b) 22.5 Tires: Top hole in jack to second hole in bracket. Use 6 bolts, 4 in welded area of bracket & 2 below welded area.

Item, Length	Description / Location	Qty	Color	Vendor PN		
Kit	(Items listed below)	1		8269	Measuring from inside of firewall, this is the end location of the hydraulic hoses where they attach to the slide mechanism.	
Pump	7-Function, 3 Rooms, Jacks	1		7301BR		
Jack	12,000 lbs, 16" Stroke	4		7214		
Touch Pad	Located to the left of the drivers seat	1		2318		
Control Box	Attached to bottom of structure	1		2730		
Flow Divider	Mounted inside pump compartment	N/A		N/A		
Hose, 132	Pump to Jack, Left Front	2	Brown	2466		
Hose, 216	Pump to Jack, Left Rear	2	Orange	2473		
Hose, 180	Pump to Jack, Right Front	2	White	2470		
Hose, 264	Pump to Jack, Right Rear	2	Yellow	2476		
Hose, N/A	Pump to Flow Divider	N/A	Green	N/A		N/A
Hose, N/A	Flow divider to front slide, Room 1	N/A	Green	N/A		N/A
Hose, N/A	Flow divider to rear slide, Room 1	N/A	Green	N/A		N/A
Hose, 36	Pump to Room 1	2	Green	2458		127 / Drivers Side
Hose, 372	Pump to Room 2	2	Purple	2481		305 / Passenger Side
Hose w90, 108	Pump to Room 3	2	Gray	2464		160 / Passenger Side
Hose, N/A	Pump to Room 4	N/A	Red	N/A		N/A
Hose, N/A	Pump to Generator Slide	N/A	N/A	N/A		N/A
Travel Clamp	Two per Slide	N/A		HWH	N/A	

Options

Revisions

**34Y HURRICANE (19.5) TIRES
EQUALIZER JACKS (FULLY AUTOMATIC)
STANDARD ON THIS UNIT**

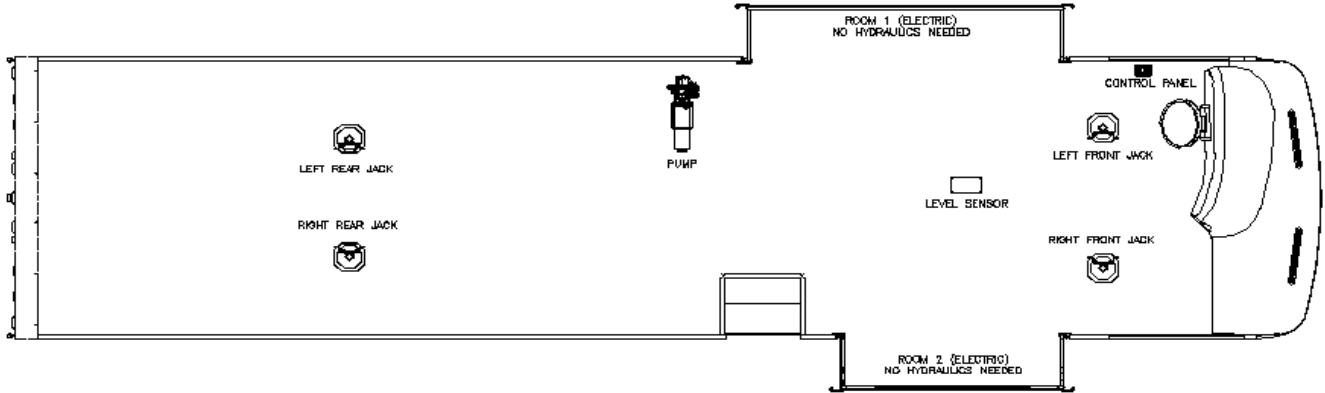

Notes:

1) Jacks mount 2nd hole from top to top mounting plate hole.

Item, Length	Description / Location	Qty	Color	Vendor PN		
Kit	(Items listed below)	1		8365	Measuring from back of cab floor, this is the end location of the hydraulic hoses where they attach to the slide mechanism.	
Pump	4-Function, Jacks Only	1		7239BR		
Jack	12,000 lbs, 16" Stroke	4		7214		
Touch Pad	Located to the left of the drivers seat	1		2318		
Control Box	Attached to bottom of structure	1		2730		
Flow Divider	Mounted inside pump compartment	N/A		N/A		
Hose, 180	Pump to Jack, Left Front	2	Brown	2470		
Hose, 180	Pump to Jack, Left Rear	2	Orange	2470		
Hose, 216	Pump to Jack, Right Front	2	White	2473		
Hose, 180	Pump to Jack, Right Rear	2	Yellow	2470		
Hose, N/A	Pump to Flow Divider	N/A	N/A	N/A		N/A
Hose, N/A	Flow divider to front slide, Room 1	N/A	N/A	N/A		N/A
Hose, N/A	Flow divider to rear slide, Room 1	N/A	N/A	N/A		N/A
Hose, N/A	Pump to Room 1	N/A	Green	N/A		N/A
Hose, N/A	Pump to Room 2	N/A	Purple	N/A		N/A
Hose, N/A	Pump to Room 3	N/A	Gray	N/A		N/A
Hose, N/A	Pump to Room 4	N/A	Red	N/A		N/A
Hose, N/A	Pump to Generator Slide	N/A	TBD	N/A		N/A
Travel Clamp	Two per Slide	N/A		HWH		N/A
Options						
Revisions						
	Description		By	Date		

**30Q HURRICANE/WINDSPORT (19.5) TIRES
EQUALIZER JACKS (FULLY AUTOMATIC)
OPTIONAL ON THIS UNIT**



Notes:

- 1) Jacks mount in two different locations on bracket depending on tire size of chassis.
 - a) 19.5 Tires: Top hole in jack to top hole in bracket. Use 4 bolts in welded area of bracket.
 - b) 22.5 Tires: Top hole in jack to second hole in bracket. Use 6 bolts, 4 in welded area of bracket & 2 below welded area.

Item, Length	Description / Location	Qty	Color	Vendor PN		
Kit	(Items listed below)	1		8252	Measuring from inside of firewall, this is the end location of the hydraulic hoses where they attach to the slide mechanism.	
Pump	4-Function, Jacks	1		7239BR		
Jack	12,000 lbs, 16" Stroke	4		7214		
Touch Pad	Located to the left of the drivers seat	1		2318		
Control Box	Attached to bottom of structure	1		2730		
Flow Divider	Mounted inside pump compartment	N/A		N/A		
Hose, 132	Pump to Jack, Left Front	2	Brown	2466		
Hose, 216	Pump to Jack, Left Rear	2	Orange	2473		
Hose, 180	Pump to Jack, Right Front	2	White	2470		
Hose, 264	Pump to Jack, Right Rear	2	Yellow	2476		
Hose, N/A	Pump to Flow Divider	N/A	Green	N/A		N/A
Hose, N/A	Flow divider to front slide, Room 1	N/A	Green	N/A		N/A
Hose, N/A	Flow divider to rear slide, Room 1	N/A	Green	N/A		N/A
Hose, N/A	Pump to Room 1	N/A	Green	N/A		N/A
Hose, N/A	Pump to Room 2	N/A	Purple	N/A		N/A
Hose, N/A	Pump to Room 3	N/A	Gray	N/A		N/A
Hose, N/A	Pump to Room 4	N/A	Red	N/A	N/A	
Hose, N/A	Pump to Generator Slide	N/A		N/A	N/A	
Travel Clamp	Two per Slide	N/A		HWH	N/A	

Options

Revisions

1	Add Windsport to Title of this chart for MY2007.
2	Update per Equalizer Specs

**31D HURRICANE/WINDSPORT (19.5) TIRES
EQUALIZER JACKS (FULLY AUTOMATIC)
OPTIONAL ON THIS UNIT**

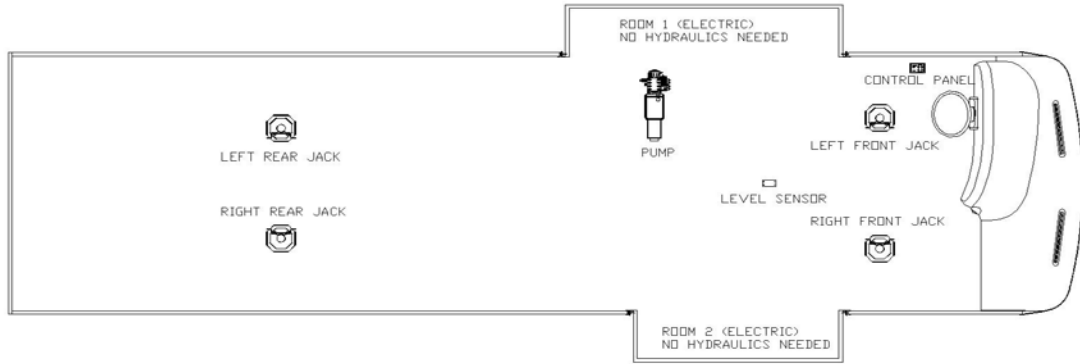

Notes:

- 1) Jacks mount in two different locations on bracket depending on tire size of chassis.
 - a) 19.5 Tires: Top hole in jack to top hole in bracket. Use 4 bolts in welded area of bracket.
 - b) 22.5 Tires: Top hole in jack to second hole in bracket. Use 6 bolts, 4 in welded area of bracket & 2 below welded area.

Item, Length	Description / Location	Qty	Color	Vendor PN	
Kit	(Items listed below)	1		8252	Measuring from inside of firewall, this is the end location of the hydraulic hoses where they attach to the slide mechanism.
Pump	4-Function, Jacks	1		7239BR	
Jack	12,000 lbs, 16" Stroke	4		7214	
Touch Pad	Located to the left of the drivers seat	1		2318	
Control Box	Attached to bottom of structure	1		2730	
Flow Divider	Mounted inside pump compartment	N/A		N/A	
Hose, 132	Pump to Jack, Left Front	2	Brown	2466	
Hose, 216	Pump to Jack, Left Rear	2	Orange	2473	
Hose, 180	Pump to Jack, Right Front	2	White	2470	
Hose, 264	Pump to Jack, Right Rear	2	Yellow	2476	
Hose, N/A	Pump to Flow Divider	N/A	Green	N/A	N/A
Hose, N/A	Flow divider to front slide, Room 1	N/A	Green	N/A	N/A
Hose, N/A	Flow divider to rear slide, Room 1	N/A	Green	N/A	N/A
Hose, N/A	Pump to Room 1	N/A	Green	N/A	N/A
Hose, N/A	Pump to Room 2	N/A	Purple	N/A	N/A
Hose, N/A	Pump to Room 3	N/A	Gray	N/A	N/A
Hose, N/A	Pump to Room 4	N/A	Red	N/A	N/A
Hose, N/A	Pump to Generator Slide	N/A		N/A	N/A
Travel Clamp	Two per Slide	N/A		HWH	N/A

Options

Revisions

1	Add Windsport to Title of this chart for MY2007.
2	Update per Equalizer Specs

**31H HURRICANE/WINDSPORT (19.5) TIRES
EQUALIZER JACKS (FULLY AUTOMATIC)
OPTIONAL ON THIS UNIT**

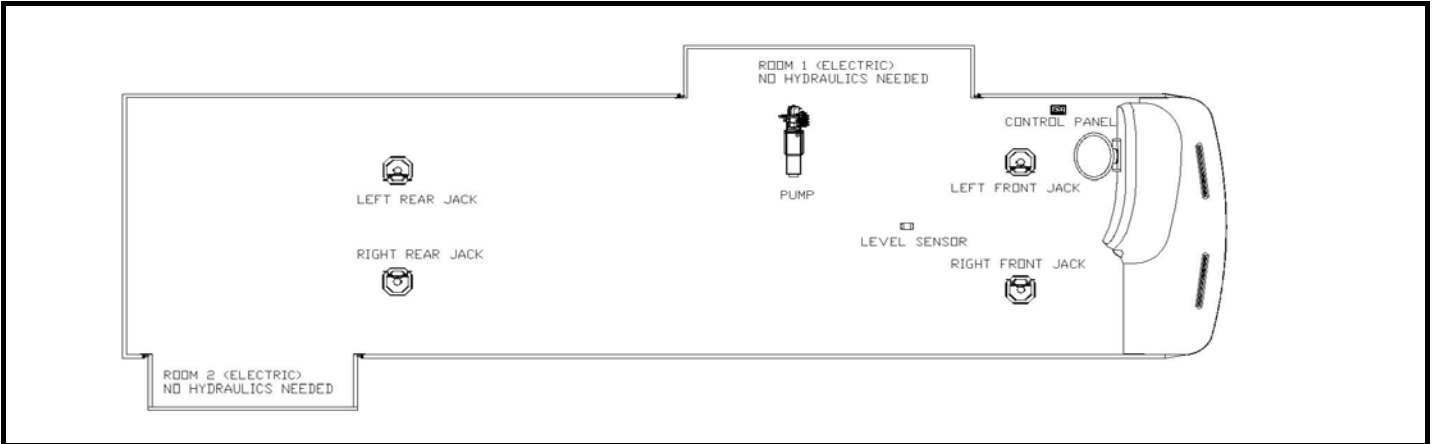

Notes:

- 1) Jacks mount in two different locations on bracket depending on tire size of chassis.
 - a) 19.5 Tires: Top hole in jack to top hole in bracket. Use 4 bolts in welded area of bracket.
 - b) 22.5 Tires: Top hole in jack to second hole in bracket. Use 6 bolts, 4 in welded area of bracket & 2 below welded area.

Item, Length	Description / Location	Qty	Color	Vendor PN		
Kit	(Items listed below)	1		8252	Measuring from inside of firewall, this is the end location of the hydraulic hoses where they attach to the slide mechanism.	
Pump	4-Function, Jacks	1		7239BR		
Jack	12,000 lbs, 16" Stroke	4		7214		
Touch Pad	Located to the left of the drivers seat	1		2318		
Control Box	Attached to bottom of structure	1		2730		
Flow Divider	Mounted inside pump compartment	N/A		N/A		
Hose, 132	Pump to Jack, Left Front	2	Brown	2466		
Hose, 216	Pump to Jack, Left Rear	2	Orange	2473		
Hose, 180	Pump to Jack, Right Front	2	White	2470		
Hose, 264	Pump to Jack, Right Rear	2	Yellow	2476		
Hose, N/A	Pump to Flow Divider	N/A	Green	N/A		N/A
Hose, N/A	Flow divider to front slide, Room 1	N/A	Green	N/A		N/A
Hose, N/A	Flow divider to rear slide, Room 1	N/A	Green	N/A		N/A
Hose, N/A	Pump to Room 1	N/A	Green	N/A		N/A
Hose, N/A	Pump to Room 2	N/A	Purple	N/A		N/A
Hose, N/A	Pump to Room 3	N/A	Gray	N/A		N/A
Hose, N/A	Pump to Room 4	N/A	Red	N/A		N/A
Hose, N/A	Pump to Generator Slide	N/A	N/A	N/A	N/A	
Travel Clamp	Two per Slide	N/A		HWH	N/A	

Options					

Revisions	
1	Add Windsport to Title of this chart for MY2007.
2	Update per Equalizer Specs

**33H HURRICANE (19.5) TIRES
EQUALIZER JACKS (FULLY AUTOMATIC)
STANDARD ON THIS UNIT**

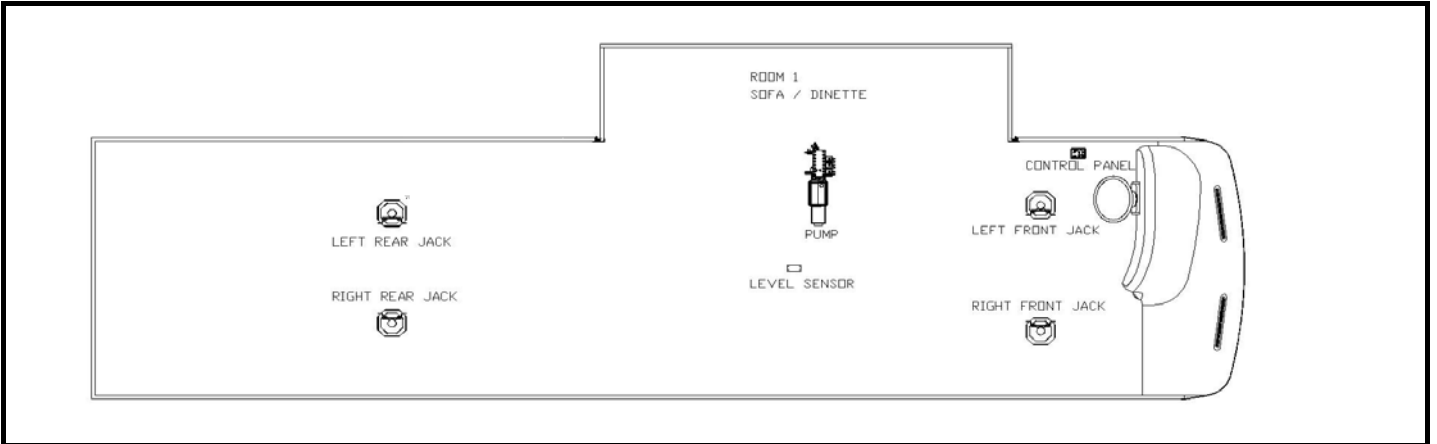

Notes:

- 1) Jacks mount in two different locations on bracket depending on tire size of chassis.
 - a) 19.5 Tires: Top hole in jack to top hole in bracket. Use 4 bolts in welded area of bracket.
 - b) 22.5 Tires: Top hole in jack to second hole in bracket. Use 6 bolts, 4 in welded area of bracket & 2 below welded area.

Item, Length	Description / Location	Qty	Color	Vendor PN	
Kit	(Items listed below)	1		8270	
Pump	5-Function, 1 Room, Jacks	1		7242BR	
Jack	12,000 lbs, 16" Stroke	4		7214	
Touch Pad	Located to the left of the drivers seat	1		2318	
Control Box	Attached to bottom of structure	1		2730	
Flow Divider	Mounted inside pump compartment	N/A		N/A	
Hose, 132	Pump to Jack, Left Front	2	Brown	2466	Measuring from inside of firewall, this is the end location of the hydraulic hoses where they attach to the slide mechanism.
Hose, 216	Pump to Jack, Left Rear	2	Orange	2473	
Hose, 180	Pump to Jack, Right Front	2	White	2470	
Hose, 264	Pump to Jack, Right Rear	2	Yellow	2476	
Hose, N/A	Pump to Flow Divider	N/A	Green	N/A	
Hose, N/A	Flow divider to front slide, Room 1	N/A	Green	N/A	
Hose, N/A	Flow divider to rear slide, Room 1	N/A	Green	N/A	
Hose, 36	Pump to Room 1	2	Green	2458	
Hose, N/A	Pump to Room 2	N/A	Purple	N/A	
Hose, N/A	Pump to Room 3	N/A	Gray	N/A	
Hose, N/A	Pump to Room 4	N/A	Red	N/A	
Hose, N/A	Pump to Generator Slide	N/A		N/A	
Travel Clamp	Two per Slide	N/A		HWH	

Options					

Revisions					
1	Update per Equalizer Specs				

**34B/34S HURRICANE (19.5) TIRES
EQUALIZER JACKS (FULLY AUTOMATIC)
STANDARD ON THIS UNIT**

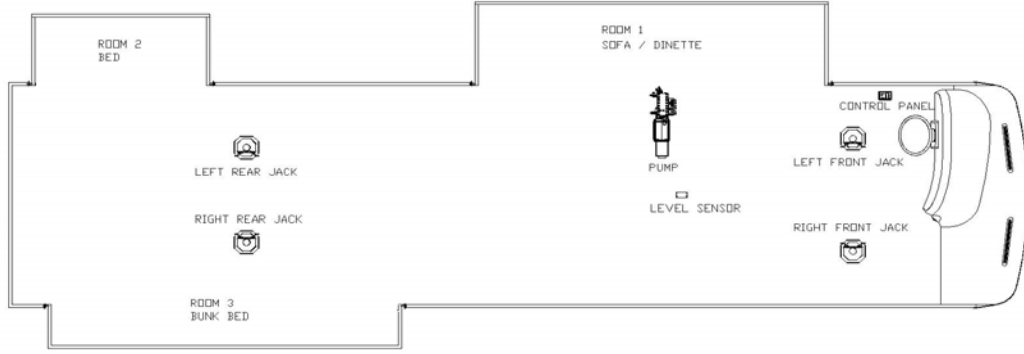

Notes:

1) Jacks mount in two different locations on bracket depending on tire size of chassis.

a) 19.5 Tires: Top hole in jack to top hole in bracket. Use 4 bolts in welded area of bracket.

b) 22.5 Tires: Top hole in jack to second hole in bracket. Use 6 bolts, 4 in welded area of bracket & 2 below welded area.

Item, Length	Description / Location	Qty	Color	Vendor PN		
Kit	(Items listed below)	1		8323	Measuring from inside of firewall, this is the end location of the hydraulic hoses where they attach to the slide mechanism.	
Pump	7-Function, 3 Rooms, Jacks	1		7301BR		
Jack	12,000 lbs, 16" Stroke	4		7214		
Touch Pad	Located to the left of the drivers seat	1		2318		
Control Box	Attached to bottom of structure	1		2730		
Flow Divider	Mounted inside pump compartment	N/A		N/A		
Hose, 132	Pump to Jack, Left Front	2	Brown	2466		
Hose, 240	Pump to Jack, Left Rear	2	Orange	2475		
Hose, 168	Pump to Jack, Right Front	2	White	2469		
Hose, 264	Pump to Jack, Right Rear	2	Yellow	2476		
Hose, N/A	Pump to Flow Divider	N/A	Green	N/A		N/A
Hose, N/A	Flow divider to front slide, Room 1	N/A	Green	N/A		N/A
Hose, N/A	Flow divider to rear slide, Room 1	N/A	Green	N/A		N/A
Hose, 36	Pump to Room 1	2	Green	2458		127 / Drivers Side
Hose, 372	Pump to Room 2	2	Purple	2481	341 / Drivers Side	
Hose w90, 372	Pump to Room 3	2	Gray	2481	300 / Passenger Side	
Hose, N/A	Pump to Room 4	N/A	Red	N/A	N/A	
Hose, N/A	Pump to Generator Slide	N/A	N/A	N/A	N/A	
Travel Clamp	Two per Slide	N/A		HWH	N/A	

Options

Revisions

9/1/2006	Add 34S to 34B chart
2	Update per Equalizer Specs

**34N HURRICANE (19.5) TIRES
EQUALIZER JACKS (FULLY AUTOMATIC)
STANDARD ON THIS UNIT**

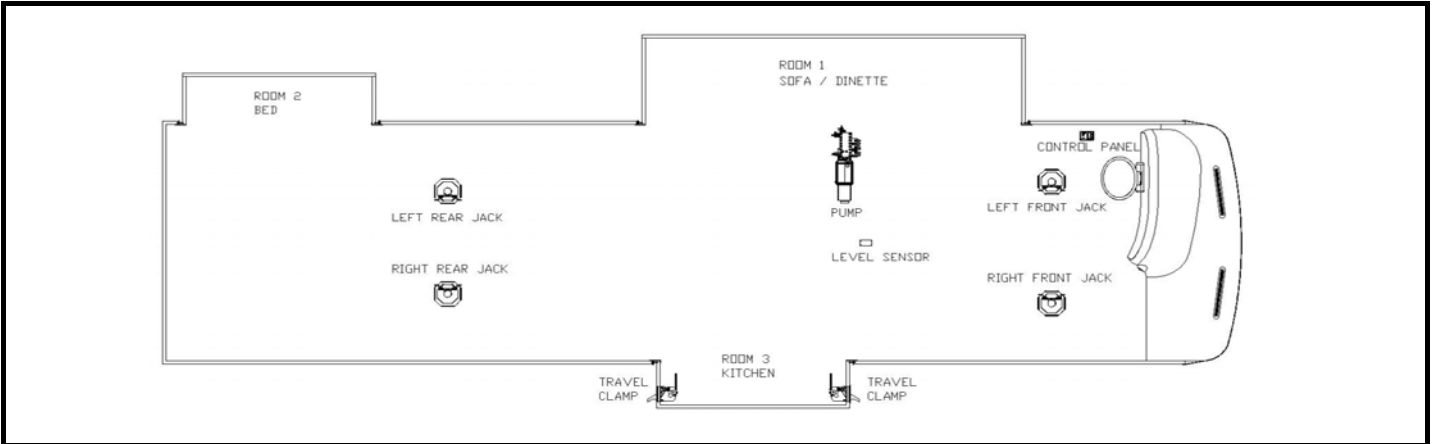

Notes:

- 1) Jacks mount in two different locations on bracket depending on tire size of chassis.
 - a) 19.5 Tires: Top hole in jack to top hole in bracket. Use 4 bolts in welded area of bracket.
 - b) 22.5 Tires: Top hole in jack to second hole in bracket. Use 6 bolts, 4 in welded area of bracket & 2 below welded area.

Item, Length	Description / Location	Qty	Color	Vendor PN		
Kit	(Items listed below)	1		8269	Measuring from inside of firewall, this is the end location of the hydraulic hoses where they attach to the slide mechanism.	
Pump	7-Function, 3 Rooms, Jacks	1		7301BR		
Jack	12,000 lbs, 16" Stroke	4		7214		
Touch Pad	Located to the left of the drivers seat	1		2318		
Control Box	Attached to bottom of structure	1		2730		
Flow Divider	Mounted inside pump compartment	N/A		N/A		
Hose, 132	Pump to Jack, Left Front	2	Brown	2466		
Hose, 216	Pump to Jack, Left Rear	2	Orange	2473		
Hose, 180	Pump to Jack, Right Front	2	White	2470		
Hose, 264	Pump to Jack, Right Rear	2	Yellow	2476		
Hose, N/A	Pump to Flow Divider	N/A	Green	N/A		N/A
Hose, N/A	Flow divider to front slide, Room 1	N/A	Green	N/A		N/A
Hose, N/A	Flow divider to rear slide, Room 1	N/A	Green	N/A		N/A
Hose, 36	Pump to Room 1	2	Green	2458		127 / Drivers Side
Hose, 372	Pump to Room 2	2	Purple	2481		305 / Passenger Side
Hose w90, 108	Pump to Room 3	2	Gray	2464	160 / Passenger Side	
Hose, N/A	Pump to Room 4	N/A	Red	N/A	N/A	
Hose, N/A	Pump to Generator Slide	N/A	N/A	N/A	N/A	
Travel Clamp	Two per Slide	N/A		HWH	N/A	

Options

Revisions

1	Update per Equalizer Specs

**34Y HURRICANE (19.5) TIRES
EQUALIZER JACKS (FULLY AUTOMATIC)
STANDARD ON THIS UNIT**

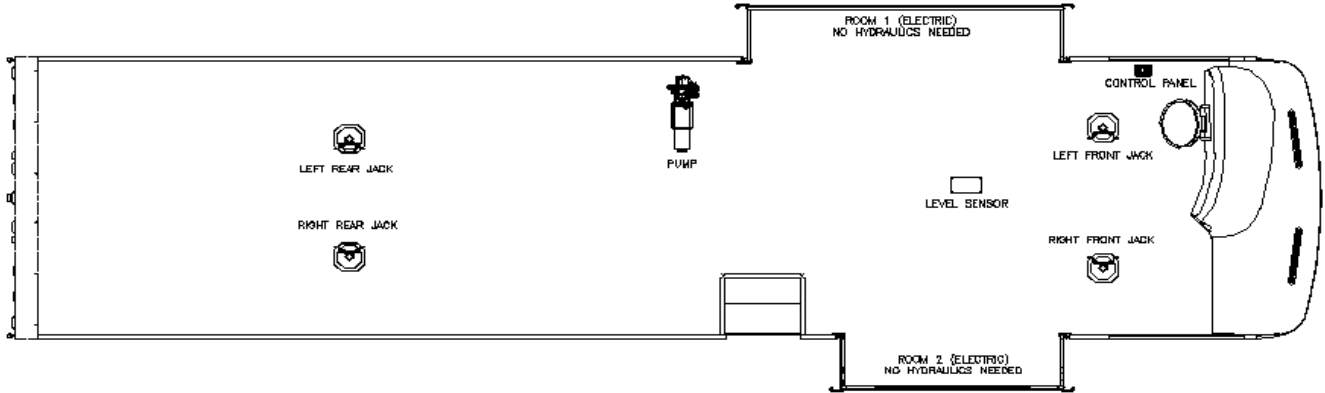

Notes:

1) Jacks mount 2nd hole from top to top mounting plate hole.

Item, Length	Description / Location	Qty	Color	Vendor PN		
Kit	(Items listed below)	1		8365	Measuring from back of cab floor, this is the end location of the hydraulic hoses where they attach to the slide mechanism.	
Pump	4-Function, Jacks Only	1		7239BR		
Jack	12,000 lbs, 16" Stroke	4		7214		
Touch Pad	Located to the left of the drivers seat	1		2318		
Control Box	Attached to bottom of structure	1		2730		
Flow Divider	Mounted inside pump compartment	N/A		N/A		
Hose, 180	Pump to Jack, Left Front	2	Brown	2470		
Hose, 180	Pump to Jack, Left Rear	2	Orange	2470		
Hose, 216	Pump to Jack, Right Front	2	White	2473		
Hose, 180	Pump to Jack, Right Rear	2	Yellow	2470		
Hose, N/A	Pump to Flow Divider	N/A	N/A	N/A		N/A
Hose, N/A	Flow divider to front slide, Room 1	N/A	N/A	N/A		N/A
Hose, N/A	Flow divider to rear slide, Room 1	N/A	N/A	N/A		N/A
Hose, N/A	Pump to Room 1	N/A	Green	N/A		N/A
Hose, N/A	Pump to Room 2	N/A	Purple	N/A		N/A
Hose, N/A	Pump to Room 3	N/A	Gray	N/A		N/A
Hose, N/A	Pump to Room 4	N/A	Red	N/A		N/A
Hose, N/A	Pump to Generator Slide	N/A	TBD	N/A		N/A
Travel Clamp	Two per Slide	N/A		HWH		N/A
Options						
Revisions						
1	Update per Equalizer Specs					

**33C FUNMOVER
EQUALIZER JACKS (FULLY AUTOMATIC)
OPTIONAL ON THIS UNIT**

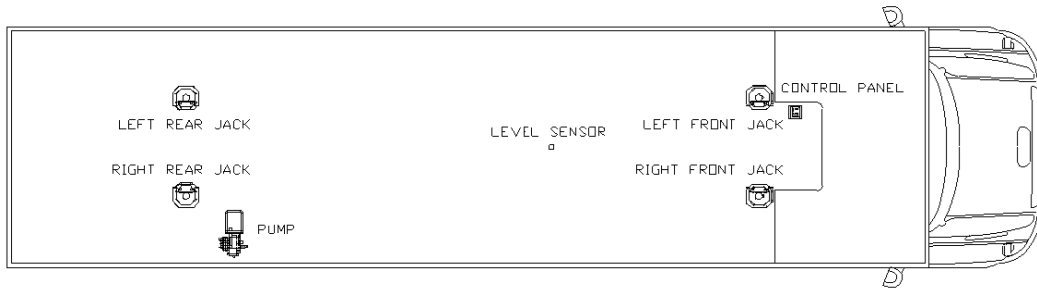

Notes:

1) Jacks mount 2nd hole from top to top mounting plate hole.

Item, Length	Description / Location	Qty	Color	Vendor PN	
Kit	(Items listed below)	1		8251	Measuring from back of cab floor, this is the end location of the hydraulic hoses where they attach to the slide mechanism.
Pump	4-Function, Jacks Only	1		7239	
Jack	12,000 lbs, 16" Stroke	4		7214	
Touch Pad	Located to the right of the drivers seat	1		2318	
Control Box	Attached to bottom of structure	1		2319	
Flow Divider	Mounted inside pump compartment	N/A		N/A	
Hose, 288	Pump to Jack, Left Front	2	Brown	2478	
Hose, 108	Pump to Jack, Left Rear	2	Orange	2464	
Hose, 276	Pump to Jack, Right Front	2	White	2477	
Hose, 60	Pump to Jack, Right Rear	2	Yellow	2460	
Hose, N/A	Pump to Flow Divider	N/A	TBD	N/A	N/A
Hose, N/A	Flow divider to front slide, Room 1	N/A	TBD	N/A	N/A
Hose, N/A	Flow divider to rear slide, Room 1	N/A	TBD	N/A	N/A
Hose, N/A	Pump to Room 1	N/A	Green	N/A	N/A
Hose, N/A	Pump to Room 2	N/A	Purple	N/A	N/A
Hose, N/A	Pump to Room 3	N/A	Gray	N/A	N/A
Hose, N/A	Pump to Room 4	N/A	Red	N/A	N/A
Hose, N/A	Pump to Generator Slide	N/A	TBD	N/A	N/A
Travel Clamp	Two per Slide	N/A		HWH	N/A
Options					
Revisions	Description		By	Date	

**34D FUNMOVER
EQUALIZER JACKS (FULLY AUTOMATIC)
OPTIONAL ON THIS UNIT**



Notes:

1) Jacks mount 2nd hole from top to top mounting plate hole.

Item, Length	Description / Location	Qty	Color	Vendor PN		
Kit	(Items listed below)	1		8251	Measuring from back of cab floor, this is the end location of the hydraulic hoses where they attach to the slide mechanism.	
Pump	4-Function, Jacks Only	1		7239		
Jack	12,000 lbs, 16" Stroke	4		7214		
Touch Pad	Located to the right of the drivers seat	1		2318		
Control Box	Attached to bottom of structure	1		2319		
Flow Divider	Mounted inside pump compartment	N/A		N/A		
Hose, 288	Pump to Jack, Left Front	2	Brown	2478		
Hose, 108	Pump to Jack, Left Rear	2	Orange	2464		
Hose, 276	Pump to Jack, Right Front	2	White	2477		
Hose, 60	Pump to Jack, Right Rear	2	Yellow	2460		
Hose, N/A	Pump to Flow Divider	N/A	TBD	N/A		N/A
Hose, N/A	Flow divider to front slide, Room 1	N/A	TBD	N/A		N/A
Hose, N/A	Flow divider to rear slide, Room 1	N/A	TBD	N/A		N/A
Hose, N/A	Pump to Room 1	N/A	Green	N/A		N/A
Hose, N/A	Pump to Room 2	N/A	Purple	N/A		N/A
Hose, N/A	Pump to Room 3	N/A	Gray	N/A		N/A
Hose, N/A	Pump to Room 4	N/A	Red	N/A		N/A
Hose, N/A	Pump to Generator Slide	N/A	TBD	N/A		N/A
Travel Clamp	Two per Slide	N/A		HWH		N/A
Options						
Revisions	Description		By	Date		

**34C FUNMOVER
EQUALIZER JACKS (FULLY AUTOMATIC)
OPTIONAL ON THIS UNIT**



Notes:

1) Jacks mount 2nd hole from top to top mounting plate hole.

Item, Length	Description / Location	Qty	Color	Vendor PN		
Kit	(Items listed below)	1		8251	Measuring from back of cab floor, this is the end location of the hydraulic hoses where they attach to the slide mechanism.	
Pump	4-Function, Jacks Only	1		7239		
Jack	12,000 lbs, 16" Stroke	4		7214		
Touch Pad	Located to the right of the drivers seat	1		2318		
Control Box	Attached to bottom of structure	1		2319		
Flow Divider	Mounted inside pump compartment	N/A		N/A		
Hose, 288	Pump to Jack, Left Front	2	Brown	2478		
Hose, 108	Pump to Jack, Left Rear	2	Orange	2464		
Hose, 276	Pump to Jack, Right Front	2	White	2477		
Hose, 60	Pump to Jack, Right Rear	2	Yellow	2460		
Hose, N/A	Pump to Flow Divider	N/A	TBD	N/A		N/A
Hose, N/A	Flow divider to front slide, Room 1	N/A	TBD	N/A		N/A
Hose, N/A	Flow divider to rear slide, Room 1	N/A	TBD	N/A		N/A
Hose, N/A	Pump to Room 1	N/A	Green	N/A		N/A
Hose, N/A	Pump to Room 2	N/A	Purple	N/A		N/A
Hose, N/A	Pump to Room 3	N/A	Gray	N/A		N/A
Hose, N/A	Pump to Room 4	N/A	Red	N/A		N/A
Hose, N/A	Pump to Generator Slide	N/A	TBD	N/A		N/A
Travel Clamp	Two per Slide	N/A		HWH		N/A
Options						
Revisions	Description		By	Date		

**35 D FUNMOVER
EQUALIZER JACKS (FULLY AUTOMATIC)
OPTIONAL ON THIS UNIT**

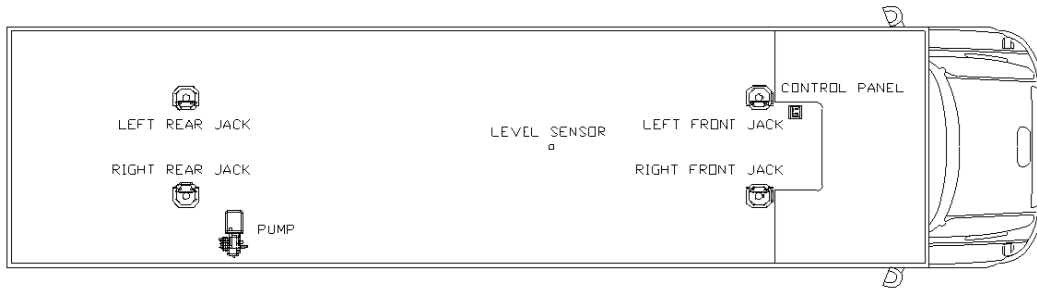

Notes:

1) Jacks mount 2nd hole from top to top mounting plate hole.

Item, Length	Description / Location	Qty	Color	Vendor PN		
Kit	(Items listed below)	1		8251	Measuring from back of cab floor, this is the end location of the hydraulic hoses where they attach to the slide mechanism.	
Pump	4-Function, Jacks Only	1		7239		
Jack	12,000 lbs, 16" Stroke	4		7214		
Touch Pad	Located to the right of the drivers seat	1		2318		
Control Box	Attached to bottom of structure	1		2319		
Flow Divider	Mounted inside pump compartment	N/A		N/A		
Hose, 288	Pump to Jack, Left Front	2	Brown	2478		
Hose, 108	Pump to Jack, Left Rear	2	Orange	2464		
Hose, 276	Pump to Jack, Right Front	2	White	2477		
Hose, 60	Pump to Jack, Right Rear	2	Yellow	2460		
Hose, N/A	Pump to Flow Divider	N/A	TBD	N/A		N/A
Hose, N/A	Flow divider to front slide, Room 1	N/A	TBD	N/A		N/A
Hose, N/A	Flow divider to rear slide, Room 1	N/A	TBD	N/A		N/A
Hose, N/A	Pump to Room 1	N/A	Green	N/A		N/A
Hose, N/A	Pump to Room 2	N/A	Purple	N/A		N/A
Hose, N/A	Pump to Room 3	N/A	Gray	N/A		N/A
Hose, N/A	Pump to Room 4	N/A	Red	N/A		N/A
Hose, N/A	Pump to Generator Slide	N/A	TBD	N/A		N/A
Travel Clamp	Two per Slide	N/A		HWH		N/A
Options						
Revisions	Description		By	Date		

39C FUN MOVER
EQUALIZER JACKS (FULLY AUTOMATIC)
OPTIONAL ON THIS UNIT

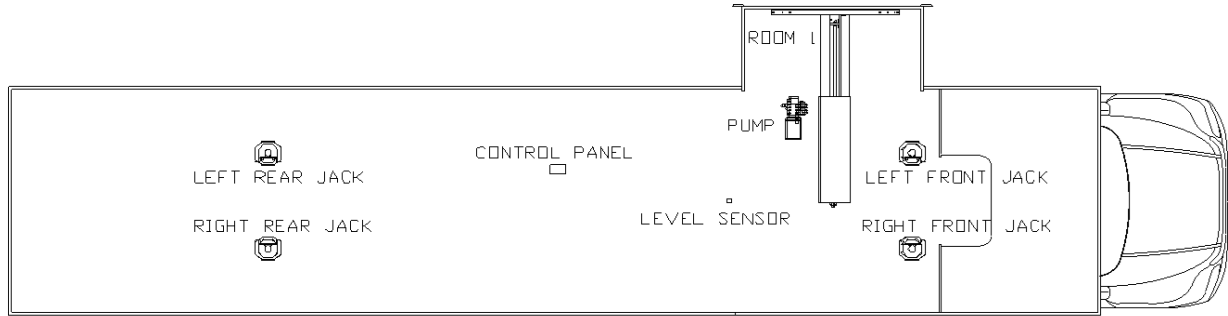

Notes:

1) Jacks mount top hole to 2nd from top mounting plate hole.

Item, Length	Description / Location	Qty	Color	Vendor PN	Measuring from back of cab floor, this is the end location of the hydraulic hoses where they attach to the slide mechanism.
Kit	(Items listed below)	1		8250	
Pump	5-Function, 1 Room, Jacks	1		7242	
Flow Divider	Mounted inside pump compartment	N/A		N/A	
Hose, N/A	Pump to Flow Divider	N/A	TBD	N/A	N/A
Hose, N/A	Flow divider to front slide, Room 1	N/A	TBD	N/A	N/A
Hose, N/A	Flow divider to rear slide, Room 1	N/A	TBD	N/A	N/A
Hose, 84	Pump to Room 1	2	Green	2462	42 / Drivers Side
Hose, N/A	Pump to Room 2	N/A	Purple	N/A	N/A
Hose, N/A	Pump to Room 3	N/A	Gray	N/A	N/A
Hose, N/A	Pump to Room 4	N/A	Red	N/A	N/A
Hose, N/A	Pump to Generator Slide	N/A	TBD	N/A	N/A
Travel Clamp	Two per Slide	N/A		HWH	N/A
Options					
Kit	(Items listed below)	1		8253	
Jack	12,000 lbs, 16" Stroke	4		7214	
Touch Pad	Located to the right of the drivers seat	1		2318	
Control Box	Attached to bottom of structure	1		2319	
Hose, 96	Pump to Jack, Left Front	2	Brown	2463	
Hose, 252	Pump to Jack, Left Rear	2	Orange	2587	
Hose, 120	Pump to Jack, Right Front	2	White	2465	
Hose, 276	Pump to Jack, Right Rear	2	Yellow	2477	
Revisions					

39D FUN MOVER
EQUALIZER JACKS (FULLY AUTOMATIC)
OPTIONAL ON THIS UNIT

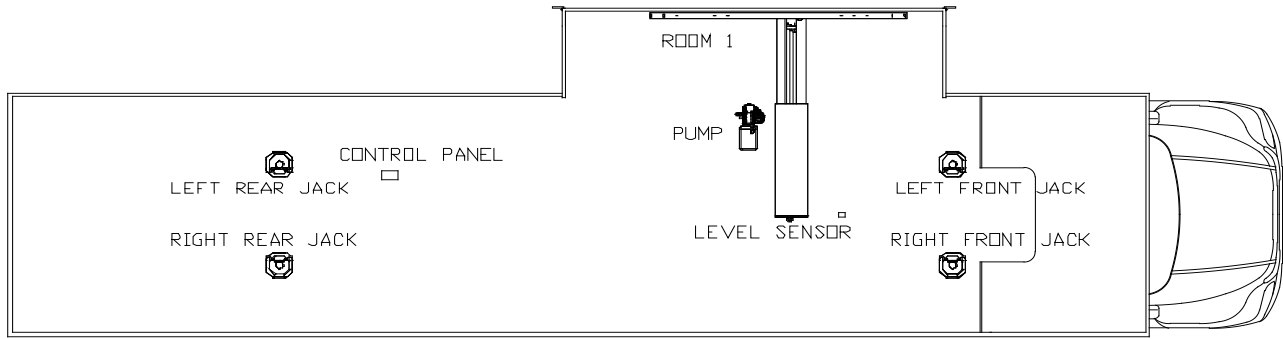

Notes:

1) Jacks mount 2nd hole from top to top mounting plate hole.

Item, Length	Description / Location	Qty	Color	Vendor PN	Measuring from back of cab floor, this is the end location of the hydraulic hoses where they attach to the slide mechanism.
Kit	(Items listed below)	1		8250	
Pump	5-Function, 1 Room, Jacks	1		7242	
Flow Divider	Mounted inside pump compartment	N/A		N/A	
Hose, N/A	Pump to Flow Divider	N/A	TBD	N/A	N/A
Hose, N/A	Flow divider to front slide, Room 1	N/A	TBD	N/A	N/A
Hose, N/A	Flow divider to rear slide, Room 1	N/A	TBD	N/A	N/A
Hose, 84	Pump to Room 1	2	Green	2462	73 / Drivers Side
Hose, N/A	Pump to Room 2	N/A	Purple	N/A	N/A
Hose, N/A	Pump to Room 3	N/A	Gray	N/A	N/A
Hose, N/A	Pump to Room 4	N/A	Red	N/A	N/A
Hose, N/A	Pump to Generator Slide	N/A	TBD	N/A	N/A
Travel Clamp	Two per Slide	N/A		HWH	N/A
Options					
Kit	(Items listed below)	1		8253	
Jack	12,000 lbs, 16" Stroke	4		7214	
Touch Pad	Located to the right of the drivers seat	1		2318	
Control Box	Attached to bottom of structure	1		2319	
Hose, 96	Pump to Jack, Left Front	2	Brown	2463	
Hose, 252	Pump to Jack, Left Rear	2	Orange	2587	
Hose, 120	Pump to Jack, Right Front	2	White	2465	
Hose, 276	Pump to Jack, Right Rear	2	Yellow	2477	
Revisions					

42D FUN MOVER
EQUALIZER JACKS (FULLY AUTOMATIC)
OPTIONAL ON THIS UNIT

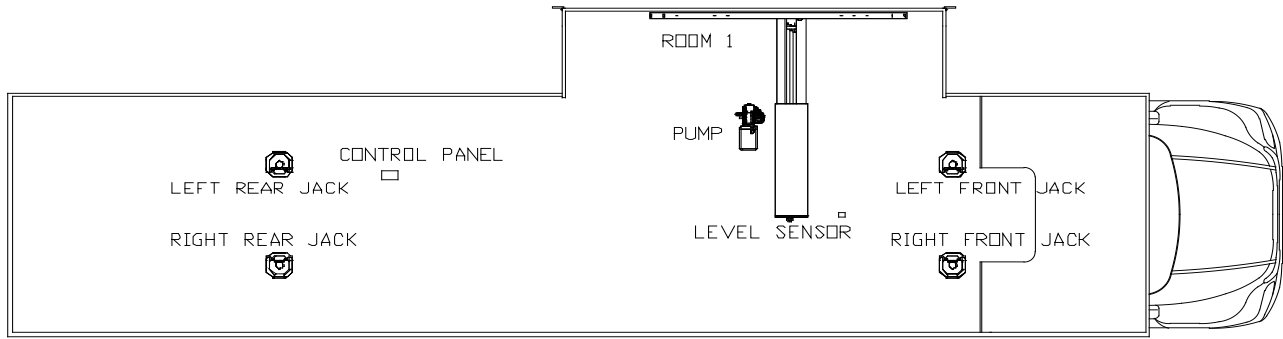

Notes:

1) Jacks mount 2nd hole from top to top mounting plate hole.

Item, Length	Description / Location	Qty	Color	Vendor PN	Measuring from back of cab floor, this is the end location of the hydraulic hoses where they attach to the slide mechanism.
Kit	(Items listed below)	1		8250	
Pump	5-Function, 1 Room, Jacks	1		7242	
Flow Divider	Mounted inside pump compartment	N/A		N/A	
Hose, N/A	Pump to Flow Divider	N/A	TBD	N/A	N/A
Hose, N/A	Flow divider to front slide, Room 1	N/A	TBD	N/A	N/A
Hose, N/A	Flow divider to rear slide, Room 1	N/A	TBD	N/A	N/A
Hose, 84	Pump to Room 1	2	Green	2462	73 / Drivers Side
Hose, N/A	Pump to Room 2	N/A	Purple	N/A	N/A
Hose, N/A	Pump to Room 3	N/A	Gray	N/A	N/A
Hose, N/A	Pump to Room 4	N/A	Red	N/A	N/A
Hose, N/A	Pump to Generator Slide	N/A	TBD	N/A	N/A
Travel Clamp	Two per Slide	N/A		HWH	N/A
Options					
Kit	(Items listed below)	1		8253	
Jack	12,000 lbs, 16" Stroke	4		7214	
Touch Pad	Located to the right of the drivers seat	1		2318	
Control Box	Attached to bottom of structure	1		2319	
Hose, 96	Pump to Jack, Left Front	2	Brown	2463	
Hose, 252	Pump to Jack, Left Rear	2	Orange	2587	
Hose, 120	Pump to Jack, Right Front	2	White	2465	
Hose, 276	Pump to Jack, Right Rear	2	Yellow	2477	
Revisions					

**32B KODIAK (19.5) TIRES
EQUALIZER JACKS (FULLY AUTOMATIC)
OPTIONAL ON THIS UNIT**

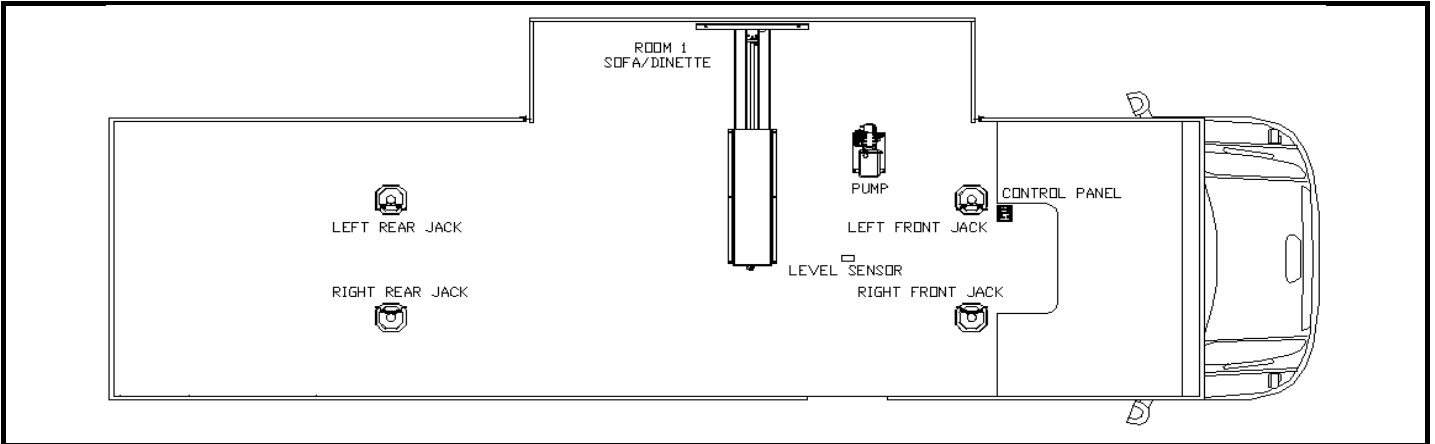

Notes:

1) Jacks mount 2nd hole from top to top mounting plate hole.

Item, Length	Description / Location	Qty	Color	Vendor PN	
Kit	(Items listed below)	1		8264	Measuring from back of cab floor, this is the end location of the hydraulic hoses where they attach to the slide mechanism.
Pump	5-Function, 1 Room, Jacks	1		7242BR	
Jack	12,000 lbs, 16" Stroke	4		7214	
Touch Pad	Located to the right of the drivers seat	1		2318	
Control Box	Attached to bottom of structure	1		2730	
Flow Divider	Mounted inside pump compartment	N/A		N/A	
Hose, 84	Pump to Jack, Left Front	2	Brown	2462	
Hose, 264	Pump to Jack, Left Rear	2	Orange	2476	
Hose, 108	Pump to Jack, Right Front	2	White	2464	
Hose, 276	Pump to Jack, Right Rear	2	Yellow	2477	
Hose, N/A	Pump to Flow Divider	N/A	TBD	N/A	N/A
Hose, N/A	Flow divider to front slide, Room 1	N/A	TBD	N/A	N/A
Hose, N/A	Flow divider to rear slide, Room 1	N/A	TBD	N/A	N/A
Hose, 84	Pump to Room 1	2	Green	2462	80 / Drivers Side
Hose, N/A	Pump to Room 2	N/A	Purple	N/A	N/A
Hose, N/A	Pump to Room 3	N/A	Gray	N/A	N/A
Hose, N/A	Pump to Room 4	N/A	Red	N/A	N/A
Hose, N/A	Pump to Generator Slide	N/A	TBD	N/A	N/A
Travel Clamp	Two per Slide	N/A		HWH	N/A
Options					
Revisions		Description		By	Date
1	Made Jack, Control Panel, Level Sensor & hoses standard			JB	11/17/2005

**33K KODIAK (19.5) TIRES
EQUALIZER JACKS (FULLY AUTOMATIC)
OPTIONAL ON THIS UNIT**

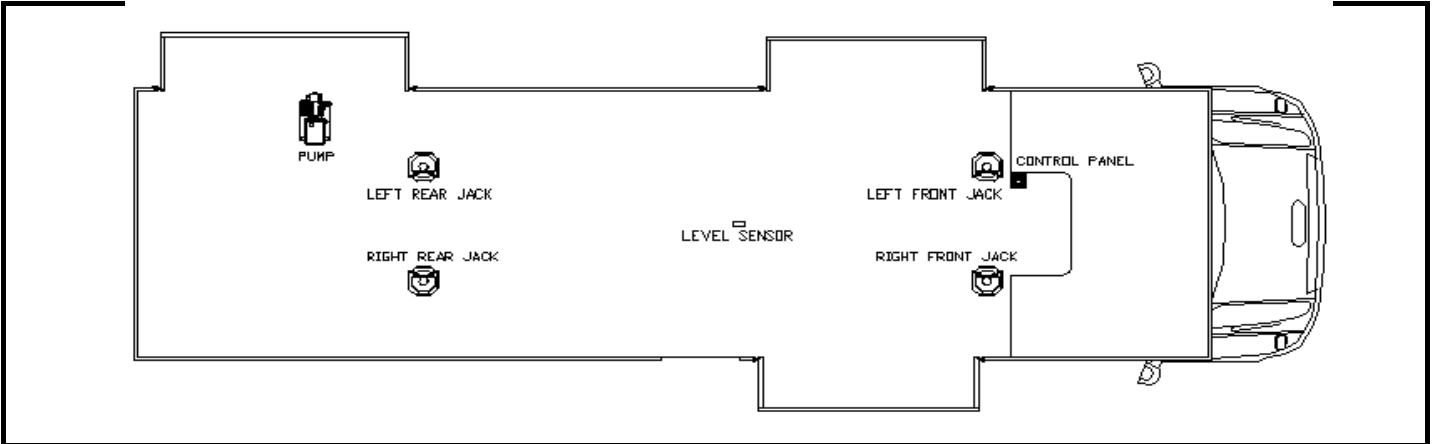

Notes:

1) Jacks mount 2nd hole from top to top mounting plate hole.

Item, Length	Description / Location	Qty	Color	Vendor PN	Measuring from back of cab floor, this is the end location of the hydraulic hoses where they attach to the slide mechanism.
Flow Divider	Mounted inside pump compartment	N/A		N/A	
Hose, N/A	Pump to Flow Divider	N/A	TBD	N/A	N/A
Hose, N/A	Flow divider to front slide, Room 1	N/A	TBD	N/A	N/A
Hose, N/A	Flow divider to rear slide, Room 1	N/A	TBD	N/A	N/A
Hose, N/A	Pump to Room 1	N/A	Green	N/A	N/A
Hose, N/A	Pump to Room 2	N/A	Purple	N/A	N/A
Hose, N/A	Pump to Room 3	N/A	Gray	N/A	N/A
Hose, N/A	Pump to Room 4	N/A	Red	N/A	N/A
Hose, N/A	Pump to Generator Slide	N/A	TBD	N/A	N/A
Travel Clamp	Two per Slide	N/A	N/A	HWH	N/A
Options					
Kit	(Items listed below)	1		8274	
Pump	4-Function, Jacks	1		7239BR	
Jack	12,000 lbs, 16" Stroke	4		7214	
Touch Pad	Located to the right of the drivers seat	1		2318	
Control Box	Attached to bottom of structure	1		2730	
Hose, 300	Pump to Jack, Left Front	2	Brown	2479	
Hose, 108	Pump to Jack, Left Rear	2	Orange	2464	
Hose, 300	Pump to Jack, Right Front	2	White	2479	
Hose, 132	Pump to Jack, Right Rear	2	Yellow	2466	
Revisions					

**34G KODIAK (19.5) TIRES
EQUALIZER JACKS (FULLY AUTOMATIC)
OPTIONAL ON THIS UNIT**

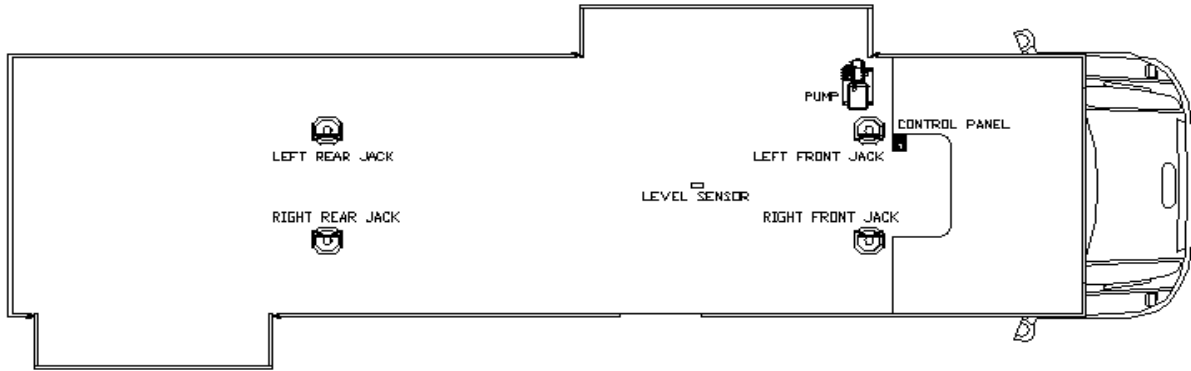

Notes:

1) Jacks mount 2nd hole from top to top mounting plate hole.

Item, Length	Description / Location	Qty	Color	Vendor PN	Measuring from back of cab floor, this is the end location of the hydraulic hoses where they attach to the slide mechanism.
Flow Divider	Mounted inside pump compartment	N/A		N/A	
Hose, N/A	Pump to Flow Divider	N/A	TBD	N/A	N/A
Hose, N/A	Flow divider to front slide, Room 1	N/A	TBD	N/A	N/A
Hose, N/A	Flow divider to rear slide, Room 1	N/A	TBD	N/A	N/A
Hose, N/A	Pump to Room 1	N/A	Green	N/A	N/A
Hose, N/A	Pump to Room 2	N/A	Purple	N/A	N/A
Hose, N/A	Pump to Room 3	N/A	Gray	N/A	N/A
Hose, N/A	Pump to Room 4	N/A	Red	N/A	N/A
Hose, N/A	Pump to Generator Slide	N/A	TBD	N/A	N/A
Travel Clamp	Two per Slide	N/A		HWH	N/A
Options					
Kit	(Items listed below)	1		8275	
Pump	4-Function, Jacks	1		7239BR	
Jack	12,000 lbs, 16" Stroke	4		7214	
Touch Pad	Located to the right of the drivers seat	1		2318	
Control Box	Attached to bottom of structure	1		2730	
Hose, 84	Pump to Jack, Left Front	2	Brown	2462	
Hose, 264	Pump to Jack, Left Rear	2	Orange	2476	
Hose, 108	Pump to Jack, Right Front	2	White	2464	
Hose, 276	Pump to Jack, Right Rear	2	Yellow	2477	
Revisions					

**34H KODIAK (19.5) TIRES
EQUALIZER JACKS (FULLY AUTOMATIC)
STANDARD ON THIS UNIT**

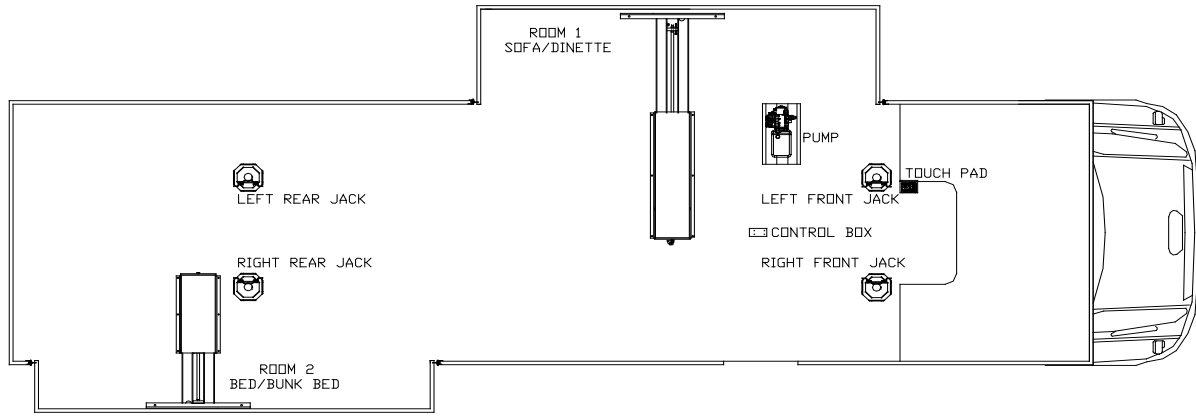

Notes:

1) Jacks mount 2nd hole from top to top mounting plate hole.

Item, Length	Description / Location	Qty	Color	Vendor PN	
Kit	(Items listed below)	1		8341	Measuring from back of cab floor, this is the end location of the hydraulic hoses where they attach to the slide mechanism.
Pump	6-Function, 2 Rooms, Jacks	1		7243BR	
Jack	12,000 lbs, 16" Stroke	4		7214	
Touch Pad	Located to the right of the drivers seat	1		2318	
Control Box	Attached to bottom of structure	1		2730	
Flow Divider	Mounted inside pump compartment	N/A		N/A	
Hose, 84	Pump to Jack, Left Front	2	Brown	2462	
Hose, 264	Pump to Jack, Left Rear	2	Orange	2476	
Hose, 108	Pump to Jack, Right Front	2	White	2464	
Hose, 276	Pump to Jack, Right Rear	2	Yellow	2477	
Hose, N/A	Pump to Flow Divider	N/A	TBD	N/A	N/A
Hose, N/A	Flow divider to front slide, Room 1	N/A	TBD	N/A	N/A
Hose, N/A	Flow divider to rear slide, Room 1	N/A	TBD	N/A	N/A
Hose, 84	Pump to Room 1	2	Green	2462	80 / Drivers Side
Hose, 300	Pump to Room 2	2	Purple	2479	245 / Passenger Side
Hose, N/A	Pump to Room 3	N/A	Gray	N/A	N/A
Hose, N/A	Pump to Room 4	N/A	Red	N/A	N/A
Hose, N/A	Pump to Generator Slide	N/A	TBD	N/A	N/A
Travel Clamp	Two per Slide	N/A		HWH	N/A
Options					
Revisions	Description		By		Date

**35B KODIAK (19.5) TIRES
EQUALIZER JACKS (FULLY AUTOMATIC)
OPTIONAL ON THIS UNIT**

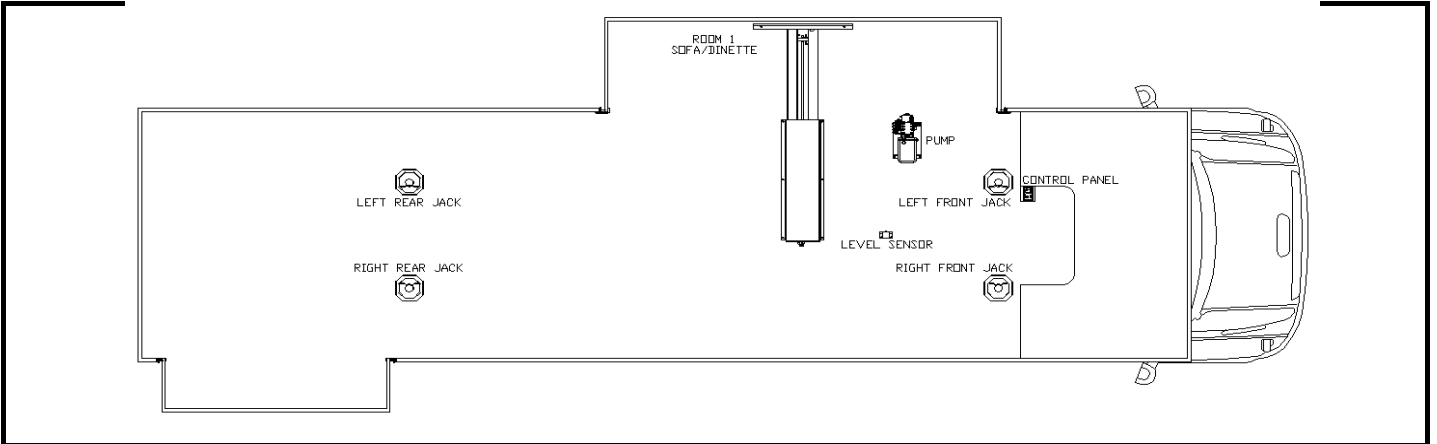

Notes:

1) Jacks mount 2nd hole from top to top mounting plate hole.

Item, Length	Description / Location	Qty	Color	Vendor PN	
Kit	(Items listed below)	1		8264	Measuring from back of cab floor, this is the end location of the hydraulic hoses where they attach to the slide mechanism.
Pump	5-Function, 1 Room, Jacks	1		7242BR	
Jack	12,000 lbs, 16" Stroke	4		7214	
Touch Pad	Located to the right of the drivers seat	1		2318	
Control Box	Attached to bottom of structure	1		2730	
Flow Divider	Mounted inside pump compartment	N/A		N/A	
Hose, 84	Pump to Jack, Left Front	2	Brown	2462	
Hose, 264	Pump to Jack, Left Rear	2	Orange	2476	
Hose, 108	Pump to Jack, Right Front	2	White	2464	
Hose, 276	Pump to Jack, Right Rear	2	Yellow	2477	
Hose, N/A	Pump to Flow Divider	N/A	TBD	N/A	N/A
Hose, N/A	Flow divider to front slide, Room 1	N/A	TBD	N/A	N/A
Hose, N/A	Flow divider to rear slide, Room 1	N/A	TBD	N/A	N/A
Hose, 84	Pump to Room 1	2	Green	2462	80 / Drivers Side
Hose, N/A	Pump to Room 2	N/A	Purple	N/A	N/A
Hose, N/A	Pump to Room 3	N/A	Gray	N/A	N/A
Hose, N/A	Pump to Room 4	N/A	Red	N/A	N/A
Hose, N/A	Pump to Generator Slide	N/A	TBD	N/A	N/A
Travel Clamp	Two per Slide	N/A		HWH	N/A
Options					
Revisions	Description		By	Date	

**35B MAGELLAN (22.5) TIRES
EQUALIZER JACKS (FULLY AUTOMATIC)
STANDARD ON THIS UNIT**

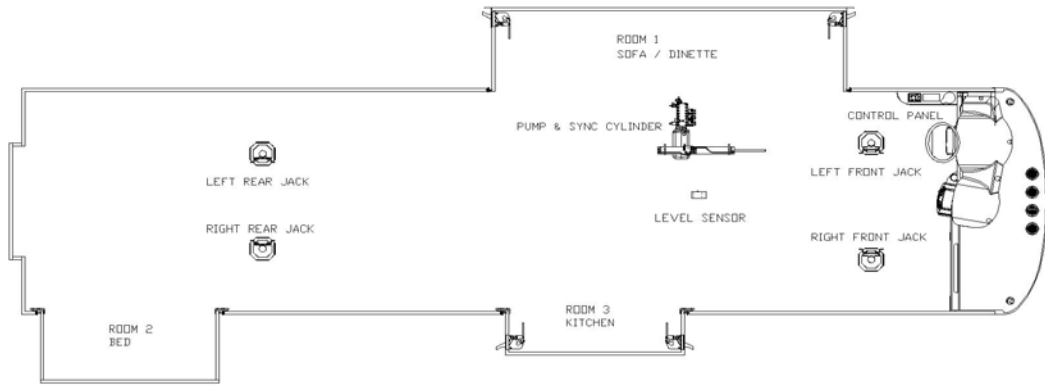

Notes:

1) Jacks mount in two different locations on bracket depending on tire size of chassis.

a) 19.5 Tires: Top hole in jack to top hole in bracket. Use 4 bolts in welded area of bracket.

b) 22.5 Tires: Top hole in jack to second hole in bracket. Use 6 bolts, 4 in welded area of bracket & 2 below welded area.

Item, Length	Description / Location	Qty	Color	Vendor PN	
Kit	(Items listed below)	1		8313	
Pump	7-Function, 2 Rooms & Jacks	1		7301	
Jack	12,000 lbs, 16" Stroke	4		7214	
Control Panel	Located to the left of the drivers seat	1		2057	
Level Sensor	Attached to bottom of structure	1		7196	
Sync Cylinder	Mounted behind pump compartment	1		7387	
Hose, 140	Pump to Jack, Left Front	2	Brown	7294	
Hose, 264	Pump to Jack, Left Rear	2	Orange	7322	
Hose, 180	Pump to Jack, Right Front	2	White	7296	
Hose, 300	Pump to Jack, Right Rear	2	Yellow	7323	
Hose, 32	Pump to sync cylinder	2	Green	7298	Inside pump compartment
Hose, 110	Sync cylinder to front slide, Room 1	2	Green	2392	95 / Drivers Side
Hose, 110	Sync cylinder to rear slide, Room 1	2	Green	2392	166 / Drivers Side
Hose, N/A	Pump to Room 1	N/A	Green	N/A	N/A
Hose, 420	Pump to Room 2	2	Purple	7313	350 / Passenger Side
Hose w90, 110	Pump to Room 3	2	Gray	7299	160 / Passenger Side
Hose, N/A	Pump to Room 4	N/A	Red	N/A	N/A
Hose, N/A	Pump to Generator Slide	N/A	N/A	N/A	N/A
Travel Clamp	Two per Slide	4		HWH	N/A

Measuring from inside of firewall, this is the end location of the hydraulic hoses where they attach to the slide mechanism.

Options

Item, Length	Description / Location	Qty	Color	Vendor PN	

1	Add this floorplan for MY2007 starting with the schedule released 04/24/06.
2	Change name from 36B to 35B still starting with the release of 04/24/06
3	Chg'd sync cylinder p/n to 7387, was 7351, see ECN-4237 12-8-06

**36E MAGELLAN (22.5) TIRES
EQUALIZER JACKS (FULLY AUTOMATIC)
STANDARD ON THIS UNIT**

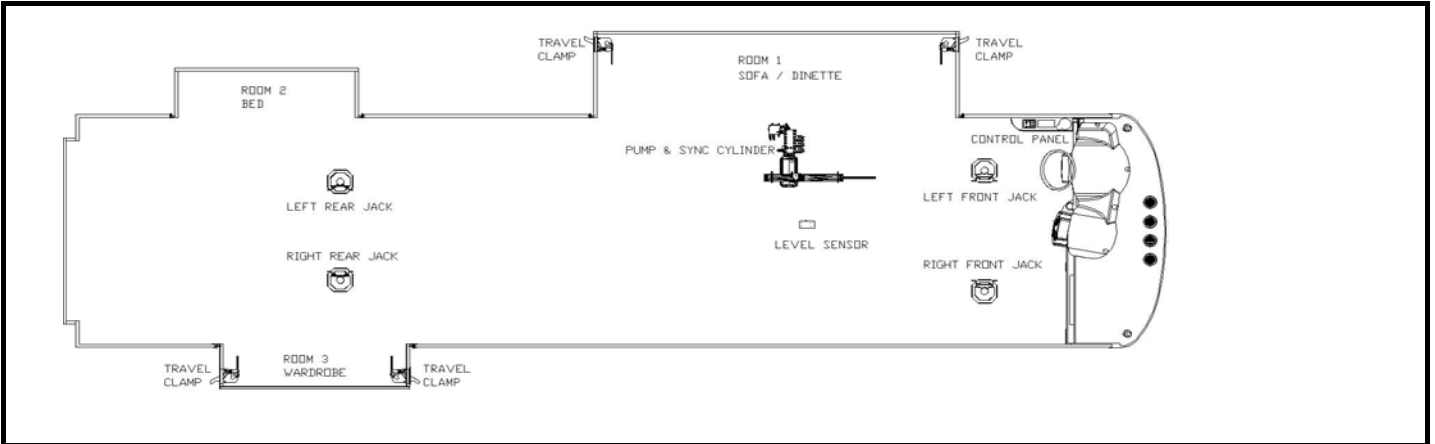

Notes:

- 1) Jacks mount in two different locations on bracket depending on tire size of chassis.
 - a) 19.5 Tires: Top hole in jack to top hole in bracket. Use 4 bolts in welded area of bracket.
 - b) 22.5 Tires: Top hole in jack to second hole in bracket. Use 6 bolts, 4 in welded area of bracket & 2 below welded area.

Item, Length	Description / Location	Qty	Color	Vendor PN		
Kit	(Items listed below)	1		8288	Measuring from inside of firewall, this is the end location of the hydraulic hoses where they attach to the slide mechanism.	
Pump	7-Function, 3 Rooms & Jacks	1		7301		
Jack	12,000 lbs, 16" Stroke	4		7214		
Control Panel	Located to the left of the drivers seat	1		2057		
Level Sensor	Attached to bottom of structure	1		7196		
Sync Cylinder	Mounted behind pump compartment	1		7387		
Hose, 140	Pump to Jack, Left Front	2	Brown	7294		
Hose, 264	Pump to Jack, Left Rear	2	Orange	7322		
Hose, 180	Pump to Jack, Right Front	2	White	7296		
Hose, 300	Pump to Jack, Right Rear	2	Yellow	7323		
Hose, 32	Pump to sync cylinder	2	Green	7298		Inside pump compartment
Hose, 110	Sync cylinder to front slide, Room 1	2	Green	2392		95 / Drivers Side
Hose, 110	Sync cylinder to rear slide, Room 1	2	Green	2392		166 / Drivers Side
Hose, N/A	Pump to Room 1	N/A	Green	N/A		N/A
Hose, 364	Pump to Room 2	2	Purple	7300		319 / Drivers Side
Hose w/90, 364	Pump to Room 3	2	Gray	7324	319 / Passenger Side	
Hose, N/A	Pump to Room 4	N/A	Red	N/A	N/A	
Hose, N/A	Pump to Generator Slide	N/A		N/A	N/A	
Travel Clamp	Two per Slide	4		HWH	N/A	

Options

Item, Length	Description / Location	Qty	Color	Vendor PN	

Revisions

1	Flow divider replaces sync cylinder, add 90 fitting to "Pump to Room 3" (addendum to original ECN 3706)
2	Windsport now has it's own chart starting with the schedule released 04/24/06, CH-0149 (MY2007)
3	Chg'd sync cylinder p/n to 7387, was 7351, see ECN-4237 12-8-06

**36K MAGELLAN (22.5) TIRES
EQUALIZER JACKS (FULLY AUTOMATIC)
STANDARD ON THIS UNIT**

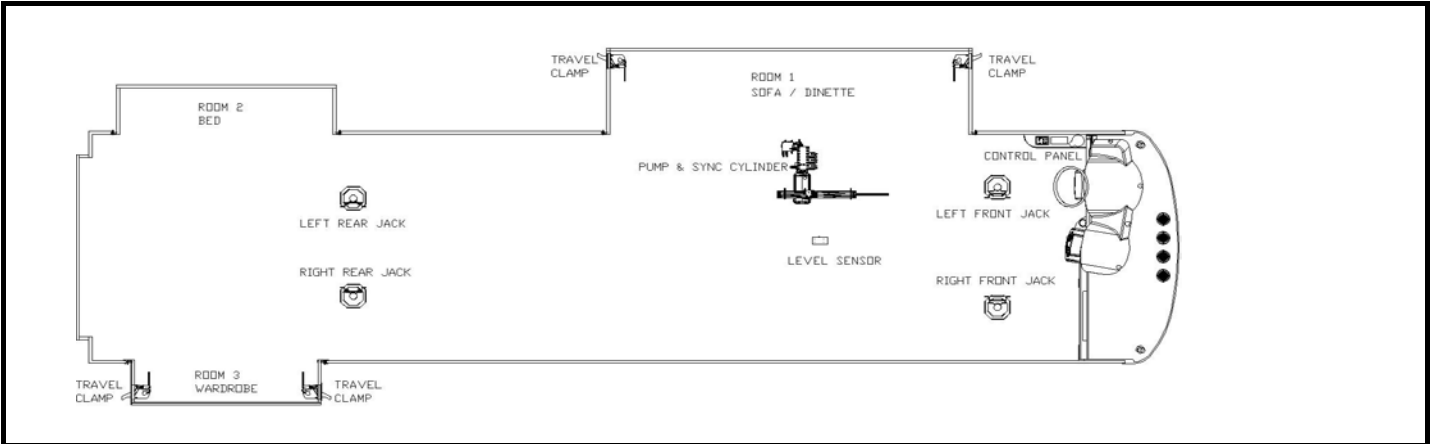

Notes:

- 1) Jacks mount in two different locations on bracket depending on tire size of chassis.
 - a) 19.5 Tires: Top hole in jack to top hole in bracket. Use 4 bolts in welded area of bracket.
 - b) 22.5 Tires: Top hole in jack to second hole in bracket. Use 6 bolts, 4 in welded area of bracket & 2 below welded area.

Item, Length	Description / Location	Qty	Color	Vendor PN		
Kit	(Items listed below)	1		8289	Measuring from inside of firewall, this is the end location of the hydraulic hoses where they attach to the slide mechanism.	
Pump	7-Function, 3 Rooms & Jacks	1		7301		
Jack	12,000 lbs, 16" Stroke	4		7214		
Control Panel	Located to the left of the drivers seat	1		2057		
Level Sensor	Attached to bottom of structure	1		7196		
Sync Cylinder	Mounted behind pump compartment	1		7387		
Hose, 140	Pump to Jack, Left Front	2	Brown	7294		
Hose, 264	Pump to Jack, Left Rear	2	Orange	7322		
Hose, 180	Pump to Jack, Right Front	2	White	7296		
Hose, 300	Pump to Jack, Right Rear	2	Yellow	7323		
Hose, 32	Pump to sync cylinder	2	Green	7298		Inside pump compartment
Hose, 110	Sync cylinder to front slide, Room 1	2	Green	2392		95 / Drivers Side
Hose, 110	Sync cylinder to rear slide, Room 1	2	Green	2392		166 / Drivers Side
Hose, N/A	Pump to Room 1	N/A	Green	N/A		N/A
Hose, 364	Pump to Room 2	2	Purple	7300		340 / Drivers Side
Hose w/90, 364	Pump to Room 3	2	Gray	7324		323 / Passenger Side
Hose, N/A	Pump to Room 4	N/A	Red	N/A	N/A	
Hose, N/A	Pump to Generator Slide	N/A		N/A	N/A	
Travel Clamp	Two per Slide	4		HWH	N/A	

Options

Item, Length	Description / Location	Qty	Color	Vendor PN	

Revisions

1	Flow divider replaces sync cylinder, add 90 fitting to "Pump to Room 3" (addendum to original ECN 3706)
2	Windsport now has it's own chart starting with the schedule released 04/24/06, CH-0149 (MY2007)
3	Chg'd sync cylinder p/n to 7387, was 7351, see ECN-4237 12-8-06

**36R MAGELLAN (22.5) TIRES
EQUALIZER JACKS (FULLY AUTOMATIC)
STANDARD ON THIS UNIT**

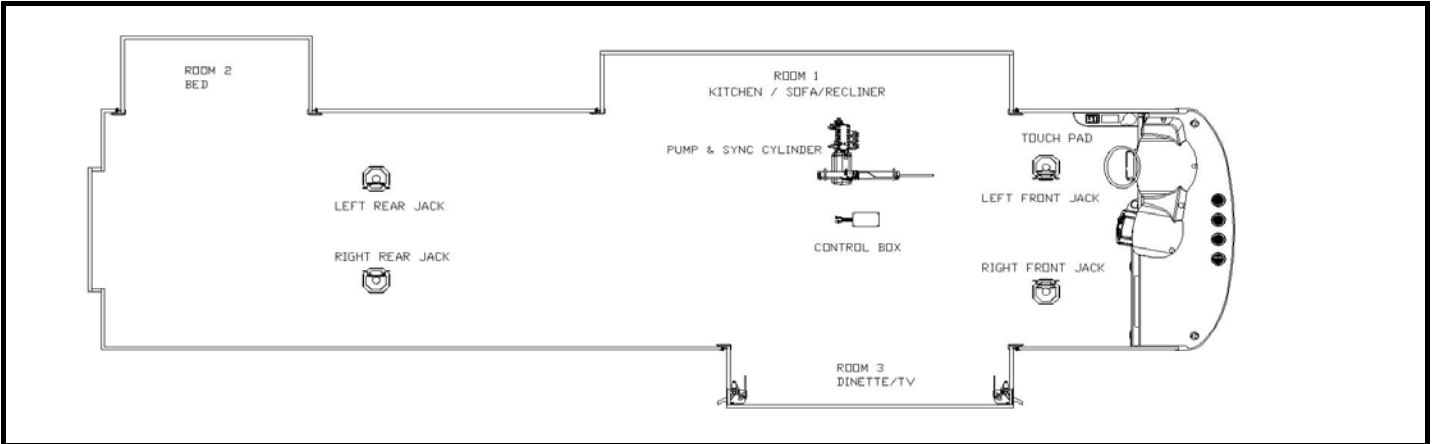

Notes:

- 1) Jacks mount in two different locations on bracket depending on tire size of chassis.
 - a) 19.5 Tires: Top hole in jack to top hole in bracket. Use 4 bolts in welded area of bracket.
 - b) 22.5 Tires: Top hole in jack to second hole in bracket. Use 6 bolts, 4 in welded area of bracket & 2 below welded area.
 - c) Hydraulic hose terminations for room #3 require 90 degree swivel elbows.

Item, Length	Description / Location	Qty	Color	Vendor PN	Measuring from inside of
Kit	(Items listed below)	1		8342	
Pump	7-Function, 3 Rooms & Jacks	1		7301	
Jack	12,000 lbs, 16" Stroke	4		7214	
Control Panel	Located to the left of the drivers seat	1		2318	
Level Sensor	Attached to bottom of structure	1		2319	
Sync Cylinder	Mounted behind pump compartment	1		7351	
Hose, 144	Pump to Jack, Left Front	2	Brown	2467	
Hose, 264	Pump to Jack, Left Rear	2	Orange	2476	
Hose, 180	Pump to Jack, Right Front	2	White	2470	
Hose, 300	Pump to Jack, Right Rear	2	Yellow	2479	
Hose, 36	Pump to sync cylinder	2	Green	2458	Inside pump compartment
Hose, 120	Sync cylinder to front slide, Room 3	2	Gray	2465	90 / Passenger Side
Hose, 120	Sync cylinder to rear slide, Room 3	2	Gray	2465	145 / Passenger Side
Hose, 36	Pump to Room 1	2	Green	2458	127 / Drivers Side
Hose, 420	Pump to Room 2	2	Purple	2485	335 / Drivers Side
Hose, N/A	Pump to Room 3	N/A	Gray	N/A	N/A
Hose, N/A	Pump to Room 4	N/A	Red	N/A	N/A
Hose, N/A	Pump to Generator Slide	N/A	N/A	N/A	N/A
Travel Clamp	Two per Slide	2		HWH	N/A
Options					

**36Z MAGELLAN (22.5) TIRES
EQUALIZER JACKS (FULLY AUTOMATIC)
STANDARD ON THIS UNIT**

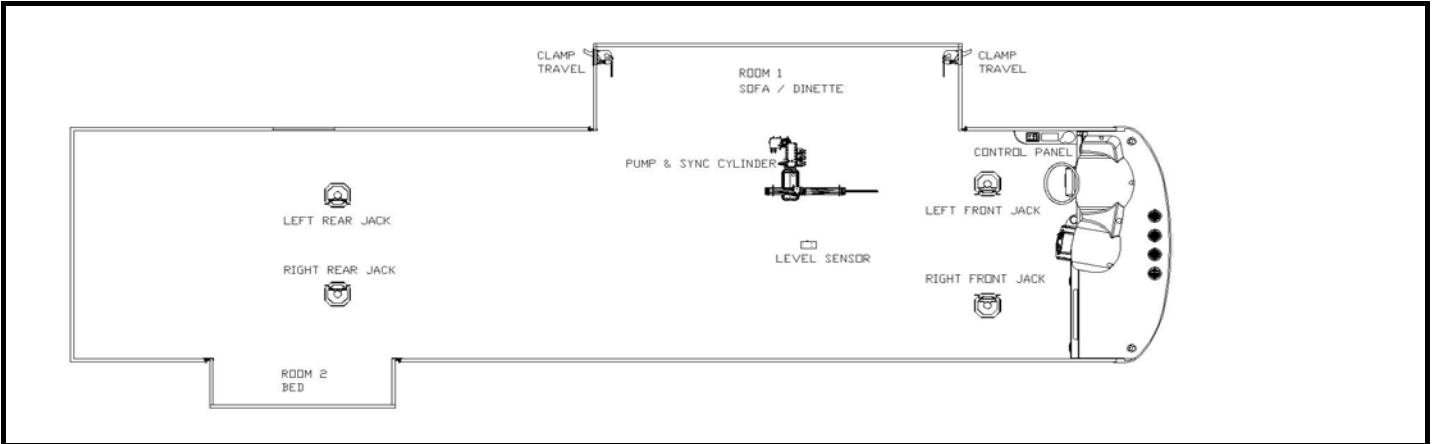

Notes:

1) Jacks mount in two different locations on bracket depending on tire size of chassis.

a) 19.5 Tires: Top hole in jack to top hole in bracket. Use 4 bolts in welded area of bracket.

b) 22.5 Tires: Top hole in jack to second hole in bracket. Use 6 bolts, 4 in welded area of bracket & 2 below welded area.

Item, Length	Description / Location	Qty	Color	Vendor PN	
Kit	(Items listed below)	1		8290	Measuring from inside of firewall, this is the end location of the hydraulic hoses where they attach to the slide mechanism.
Pump	6-Function, 2 Rooms & Jacks	1		7243	
Jack	12,000 lbs, 16" Stroke	4		7214	
Control Panel	Located to the left of the drivers seat	1		2057	
Level Sensor	Attached to bottom of structure	1		7196	
Sync Cylinder	Mounted behind pump compartment	1		7387	
Hose, 140	Pump to Jack, Left Front	2	Brown	7294	
Hose, 264	Pump to Jack, Left Rear	2	Orange	7322	
Hose, 180	Pump to Jack, Right Front	2	White	7296	
Hose, 300	Pump to Jack, Right Rear	2	Yellow	7323	
Hose, 32	Pump to sync cylinder	2	Green	7298	Inside pump compartment
Hose, 110	Sync cylinder to front slide, Room 1	2	Green	2392	95 / Drivers Side
Hose, 110	Sync cylinder to rear slide, Room 1	2	Green	2392	166 / Drivers Side
Hose, N/A	Pump to Room 1	N/A	Green	N/A	N/A
Hose, 364	Pump to Room 2	2	Purple	7300	319 / Passenger Side
Hose, N/A	Pump to Room 3	N/A	Gray	N/A	N/A
Hose, N/A	Pump to Room 4	N/A	Red	N/A	N/A
Hose, N/A	Pump to Generator Slide	N/A		N/A	N/A
Travel Clamp	Two per Slide	2		HWH	N/A

Options

Revisions

1	Flow divider replaces sync cylinder (addendum to original ECN 3706)
2	Windsport now has it's own chart starting with the schedule released 04/24/06, CH-0149 (MY2007)
3	Chg'd sync cylinder p/n to 7387, was 7351, see ECN-4237 12-8-06

**38E MAGELLAN (22.5) TIRES
EQUALIZER JACKS (FULLY AUTOMATIC)
STANDARD ON THIS UNIT**

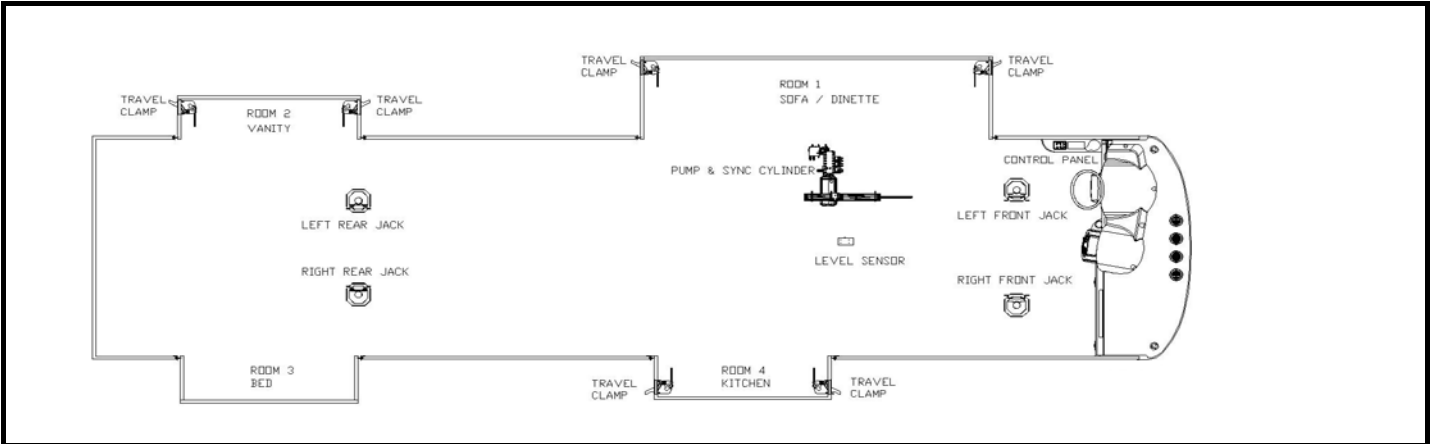

Notes:

- 1) Jacks mount in two different locations on bracket depending on tire size of chassis.
 - a) 19.5 Tires: Top hole in jack to top hole in bracket. Use 4 bolts in welded area of bracket.
 - b) 22.5 Tires: Top hole in jack to second hole in bracket. Use 6 bolts, 4 in welded area of bracket & 2 below welded area.

Item, Length	Description / Location	Qty	Color	Vendor PN		
Kit	(Items listed below)	1		8291	Measuring from inside of firewall, this is the end location of the hydraulic hoses where they attach to the slide mechanism.	
Pump	8-Function, 4 Rooms & Jacks	1		7302		
Jack	12,000 lbs, 16" Stroke	4		7214		
Control Panel	Located to the left of the drivers seat	1		2057		
Level Sensor	Attached to bottom of structure	1		7196		
Sync Cylinder	Mounted behind pump compartment	1		7387		
Hose, 140	Pump to Jack, Left Front	2	Brown	7294		
Hose, 282	Pump to Jack, Left Rear	2	Orange	7325		
Hose, 180	Pump to Jack, Right Front	2	White	7296		
Hose, 318	Pump to Jack, Right Rear	2	Yellow	7326		
Hose, 32	Pump to sync cylinder	2	Green	7298		Inside pump compartment
Hose, 110	Sync cylinder to front slide, Room 1	2	Green	2392		95 / Drivers Side
Hose, 110	Sync cylinder to rear slide, Room 1	2	Green	2392		166 / Drivers Side
Hose, N/A	Pump to Room 1	N/A	Green	N/A	N/A	
Hose, 364	Pump to Room 2	2	Purple	7300	356 / Drivers Side	
Hose, 396	Pump to Room 3	2	Gray	7327	344 / Passenger Side	
Hose w/90, 110	Pump to Room 4	2	Red	7328	160 / Passenger Side	
Hose, N/A	Pump to Generator Slide	N/A		N/A	N/A	
Travel Clamp	Two per Slide	6		HWH	N/A	

Options

Item, Length	Description / Location	Qty	Color	Vendor PN	

Revisions

1	Flow divider replaces sync cylinder, add 90 fitting to "Pump to Room 4" (addendum to original ECN 3706)
2	Windsport now has it's own chart starting with the schedule released 04/24/06, CH-0149 (MY2007)
3	Chg'd sync cylinder p/n to 7387, was 7351, see ECN-4237 12-8-06

**35B MAGELLAN (22.5) TIRES
EQUALIZER JACKS (FULLY AUTOMATIC)
STANDARD ON THIS UNIT**

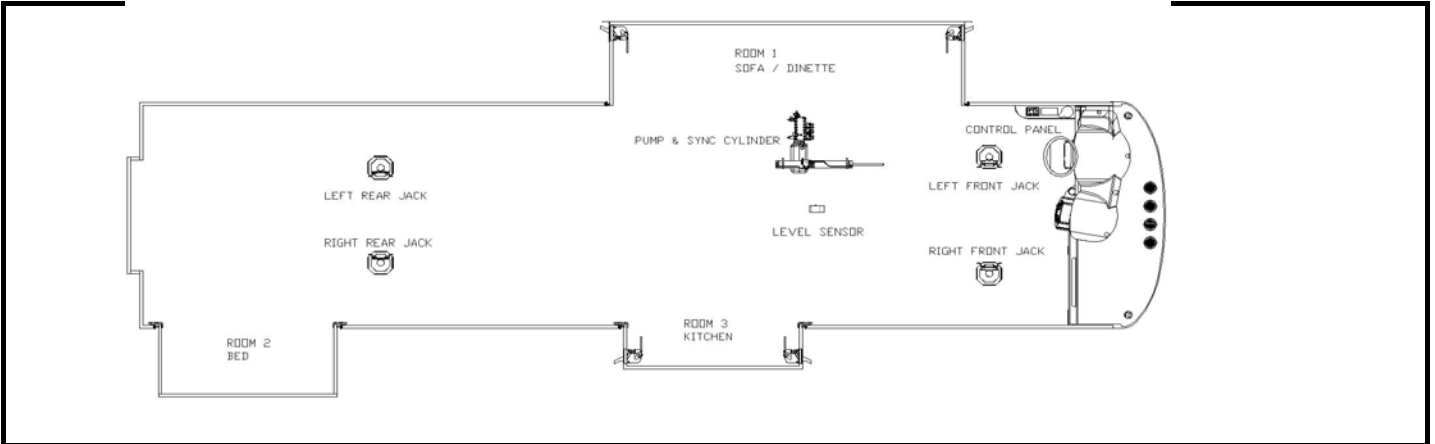

Notes:

- 1) Jacks mount in two different locations on bracket depending on tire size of chassis.
 - a) 19.5 Tires: Top hole in jack to top hole in bracket. Use 4 bolts in welded area of bracket.
 - b) 22.5 Tires: Top hole in jack to second hole in bracket. Use 6 bolts, 4 in welded area of bracket & 2 below welded area.

Item, Length	Description / Location	Qty	Color	Vendor PN		
Kit	(Items listed below)	1		8313		
Pump	7-Function, 2 Rooms & Jacks	1		7301BR		
Jack	12,000 lbs, 16" Stroke	4		7214		
Touch Pad	Located to the left of the drivers seat	1		2318		
Control Box	Attached to bottom of structure	1		2730		
Sync Cylinder	Mounted behind pump compartment	1		7387		
Hose, 144	Pump to Jack, Left Front	2	Brown	2467	Measuring from inside of firewall, this is the end location of the hydraulic hoses where they attach to the slide mechanism.	
Hose, 264	Pump to Jack, Left Rear	2	Orange	2476		
Hose, 180	Pump to Jack, Right Front	2	White	2470		
Hose, 300	Pump to Jack, Right Rear	2	Yellow	2479		
Hose, 36	Pump to sync cylinder	2	Green	2458		Inside pump compartment
Hose, 108	Sync cylinder to front slide, Room 1	2	Green	2464		95 / Drivers Side
Hose, 108	Sync cylinder to rear slide, Room 1	2	Green	2464		166 / Drivers Side
Hose, N/A	Pump to Room 1	N/A	Green	N/A		N/A
Hose, 420	Pump to Room 2	2	Purple	2485		350 / Passenger Side
Hose w90, 108	Pump to Room 3	2	Gray	2464		160 / Passenger Side
Hose, N/A	Pump to Room 4	N/A	Red	N/A	N/A	
Hose, N/A	Pump to Generator Slide	N/A		N/A	N/A	
Travel Clamp	Two per Slide	4		HWH	N/A	

Options					

1	Add this floorplan for MY2007 starting with the schedule released 04/24/06.
2	Change name from 36B to 35B still starting with the release of 04/24/06
3	Chg'd sync cylinder p/n to 7387, was 7351, see ECN-4237 12-8-06

**36E MAGELLAN (22.5) TIRES
EQUALIZER JACKS (FULLY AUTOMATIC)
STANDARD ON THIS UNIT**

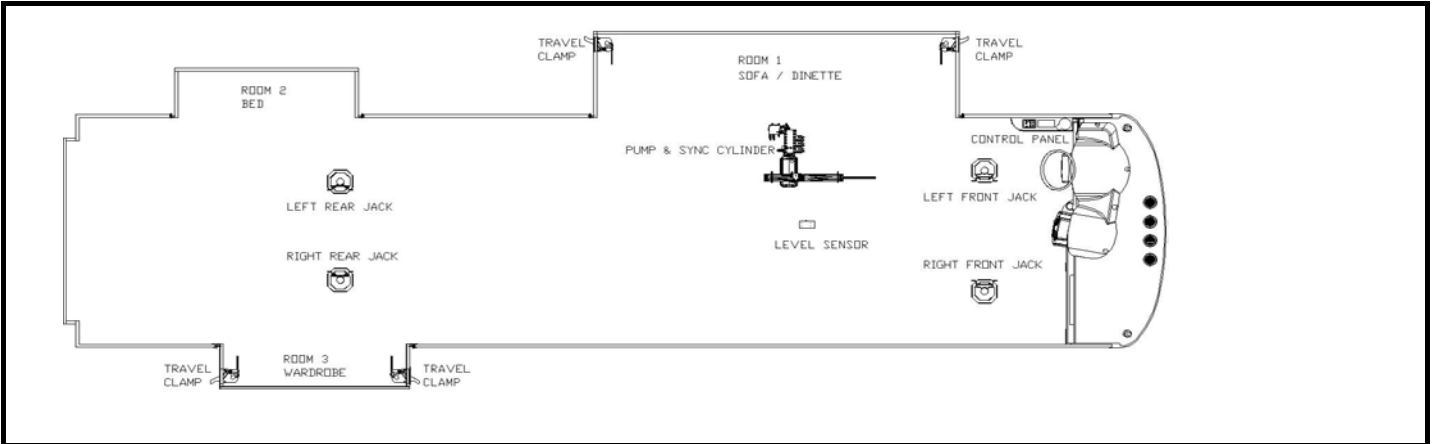

Notes:

- 1) Jacks mount in two different locations on bracket depending on tire size of chassis.
 - a) 19.5 Tires: Top hole in jack to top hole in bracket. Use 4 bolts in welded area of bracket.
 - b) 22.5 Tires: Top hole in jack to second hole in bracket. Use 6 bolts, 4 in welded area of bracket & 2 below welded area.

Item, Length	Description / Location	Qty	Color	Vendor PN	
Kit	(Items listed below)	1		8288	Measuring from inside of firewall, this is the end location of the hydraulic hoses where they attach to the slide mechanism.
Pump	7-Function, 3 Rooms & Jacks	1		7301BR	
Jack	12,000 lbs, 16" Stroke	4		7214	
Touch Pad	Located to the left of the drivers seat	1		2318	
Control Box	Attached to bottom of structure	1		2730	
Sync Cylinder	Mounted behind pump compartment	1		7387	
Hose, 120	Pump to Jack, Left Front	2	Brown	2465	
Hose, 228	Pump to Jack, Left Rear	2	Orange	2474	
Hose, 168	Pump to Jack, Right Front	2	White	2469	
Hose, 252	Pump to Jack, Right Rear	2	Yellow	2587	
Hose, 36	Pump to sync cylinder	2	Green	2458	Inside pump compartment
Hose, 108	Sync cylinder to front slide, Room 1	2	Green	2464	95 / Drivers Side
Hose, 108	Sync cylinder to rear slide, Room 1	2	Green	2464	166 / Drivers Side
Hose, N/A	Pump to Room 1	N/A	Green	N/A	N/A
Hose, 372	Pump to Room 2	2	Purple	2481	319 / Drivers Side
Hose w/90, 372	Pump to Room 3	2	Gray	2481	319 / Passenger Side
Hose, N/A	Pump to Room 4	N/A	Red	N/A	N/A
Hose, N/A	Pump to Generator Slide	N/A	N/A	N/A	N/A
Travel Clamp	Two per Slide	4		HWH	N/A

Options

Item, Length	Description / Location	Qty	Color	Vendor PN	

Revisions

1	Flow divider replaces sync cylinder, add 90 fitting to "Pump to Room 3" (addendum to original ECN 3706)
2	Windsport now has it's own chart starting with the schedule released 04/24/06, CH-0149 (MY2007)
3	Chg'd sync cylinder p/n to 7387, was 7351, see ECN-4237 12-8-06

**36F MAGELLAN (22.5) TIRES
EQUALIZER JACKS (FULLY AUTOMATIC)
STANDARD ON THIS UNIT**

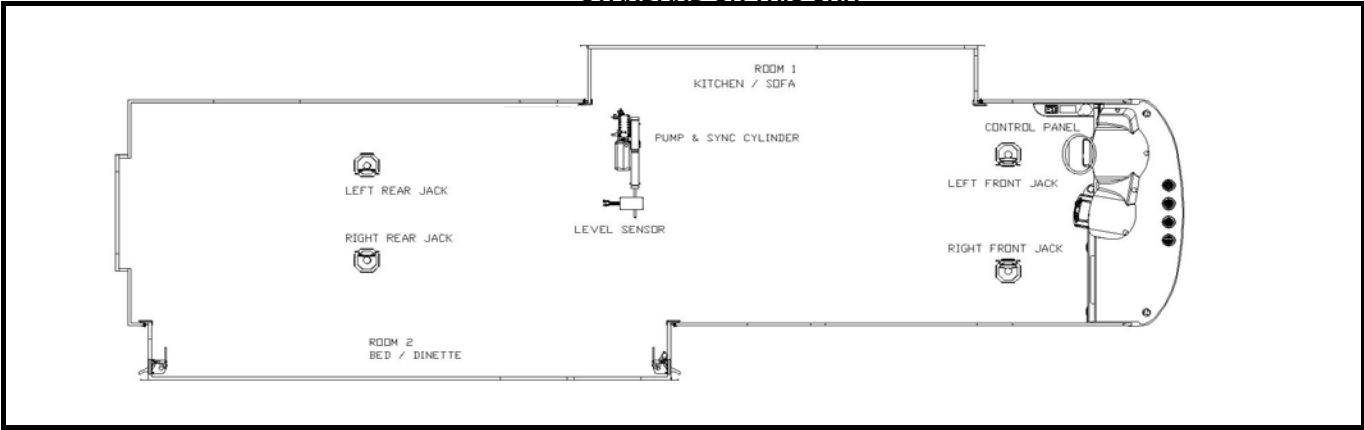

Notes:

- 1) Jacks mount in two different locations on bracket depending on tire size of chassis.
 a) 19.5 Tires: Top hole in jack to top hole in bracket. Use 4 bolts in welded area of bracket.
 b) 22.5 Tires: Top hole in jack to second hole in bracket. Use 6 bolts, 4 in welded area of bracket & 2 below welded area.
 c) Hydraulic hose terminations for both rooms require 90 degree swivel elbows.

Item, Length	Description / Location	Qty	Color	Vendor PN		
Kit	(Items listed below)	1		8366	Measuring from inside of firewall, this is the end location of the hydraulic hoses where they attach to the slide mechanism.	
Pump	6-Function, 2 Rooms & Jacks	1		7243BR		
Jack	12,000 lbs, 16" Stroke	4		7214		
Touch Pad	Located to the left of the drivers seat	1		2318		
Level Controller	Attached to bottom of structure	1		2730		
Sync Cylinder	Mounted inside pump compartment	1		7397		
Hose, 228	Pump to Jack, Left Front	2	Brown	2474		
Hose, 168	Pump to Jack, Left Rear	2	Orange	2469		
Hose, 264	Pump to Jack, Right Front	2	White	2476		
Hose, 204	Pump to Jack, Right Rear	2	Yellow	2472		
Hose, 36	Pump to sync cylinder	2	Purple	2458		Inside pump compartment
Hose w/90, 240	Sync cylinder to front slide, Room 2	2	Purple	2475		225 / Passenger Side
Hose w/90, 240	Sync cylinder to rear slide, Room 2	2	Purple	2475		371 / Passenger Side
Slide Unit	Room 2 - 24" flush floor slide (angled)	2		7388		
Hose w/90, 120	Pump to Room 1	2	Green	2465	135 / Drivers Side	
Slide Unit	Room 1 - 24" above floor slide	1		7369		
Hose, N/A	Pump to Room 2	N/A	Purple	N/A	N/A	
Hose, N/A	Pump to Room 3	N/A	Gray	N/A	N/A	
Hose, N/A	Pump to Room 4	N/A	Red	N/A	N/A	
Hose, N/A	Pump to Generator Slide	N/A		N/A	N/A	
Travel Clamp	Two per Slide	2		HWH	N/A	

Options					

**36K MAGELLAN (22.5) TIRES
EQUALIZER JACKS (FULLY AUTOMATIC)
STANDARD ON THIS UNIT**

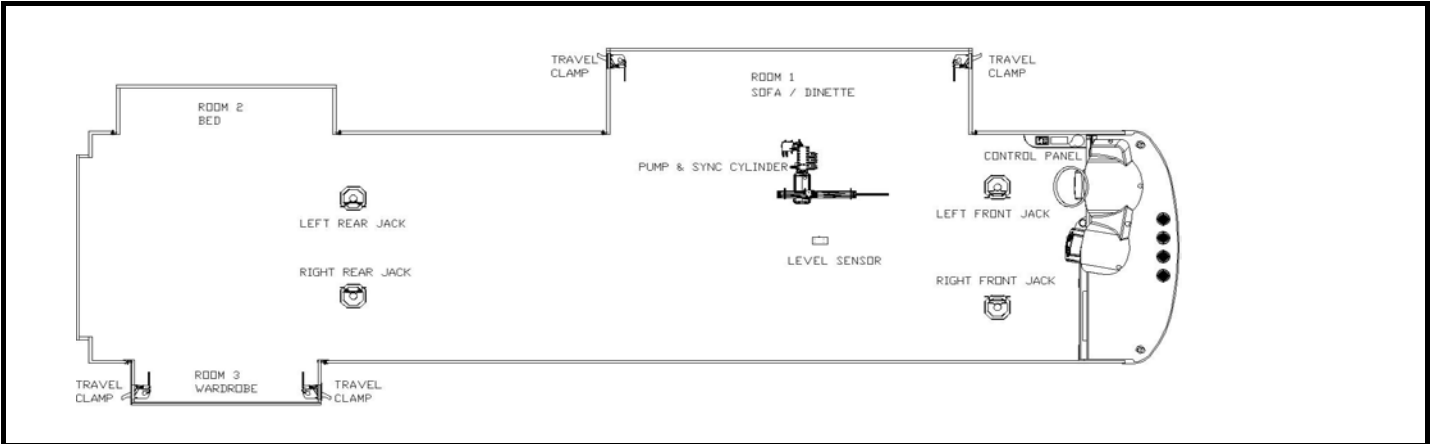

Notes:

- 1) Jacks mount in two different locations on bracket depending on tire size of chassis.
 - a) 19.5 Tires: Top hole in jack to top hole in bracket. Use 4 bolts in welded area of bracket.
 - b) 22.5 Tires: Top hole in jack to second hole in bracket. Use 6 bolts, 4 in welded area of bracket & 2 below welded area.

Item, Length	Description / Location	Qty	Color	Vendor PN		
Kit	(Items listed below)	1		8289	Measuring from inside of firewall, this is the end location of the hydraulic hoses where they attach to the slide mechanism.	
Pump	7-Function, 3 Rooms & Jacks	1		7301BR		
Jack	12,000 lbs, 16" Stroke	4		7214		
Touch Pad	Located to the left of the drivers seat	1		2318		
Control Box	Attached to bottom of structure	1		2730		
Sync Cylinder	Mounted behind pump compartment	1		7387		
Hose, 144	Pump to Jack, Left Front	2	Brown	2467		
Hose, 264	Pump to Jack, Left Rear	2	Orange	2476		
Hose, 180	Pump to Jack, Right Front	2	White	2470		
Hose, 300	Pump to Jack, Right Rear	2	Yellow	2479		
Hose, 36	Pump to sync cylinder	2	Green	2458		Inside pump compartment
Hose, 108	Sync cylinder to front slide, Room 1	2	Green	2464		95 / Drivers Side
Hose, 108	Sync cylinder to rear slide, Room 1	2	Green	2464		166 / Drivers Side
Hose, N/A	Pump to Room 1	N/A	Green	N/A		N/A
Hose, 372	Pump to Room 2	2	Purple	2481	340 / Drivers Side	
Hose w/90, 372	Pump to Room 3	2	Gray	2481	323 / Passenger Side	
Hose, N/A	Pump to Room 4	N/A	Red	N/A	N/A	
Hose, N/A	Pump to Generator Slide	N/A		N/A	N/A	
Travel Clamp	Two per Slide	4		HWH	N/A	

Options					

Revisions	
1	Flow divider replaces sync cylinder, add 90 fitting to "Pump to Room 3" (addendum to original ECN 3706)
2	Windsport now has it's own chart starting with the schedule released 04/24/06, CH-0149 (MY2007)
3	Chg'd sync cylinder p/n to 7387, was 7351, see ECN-4237 12-8-06

**36R MAGELLAN (22.5) TIRES
EQUALIZER JACKS (FULLY AUTOMATIC)
STANDARD ON THIS UNIT**

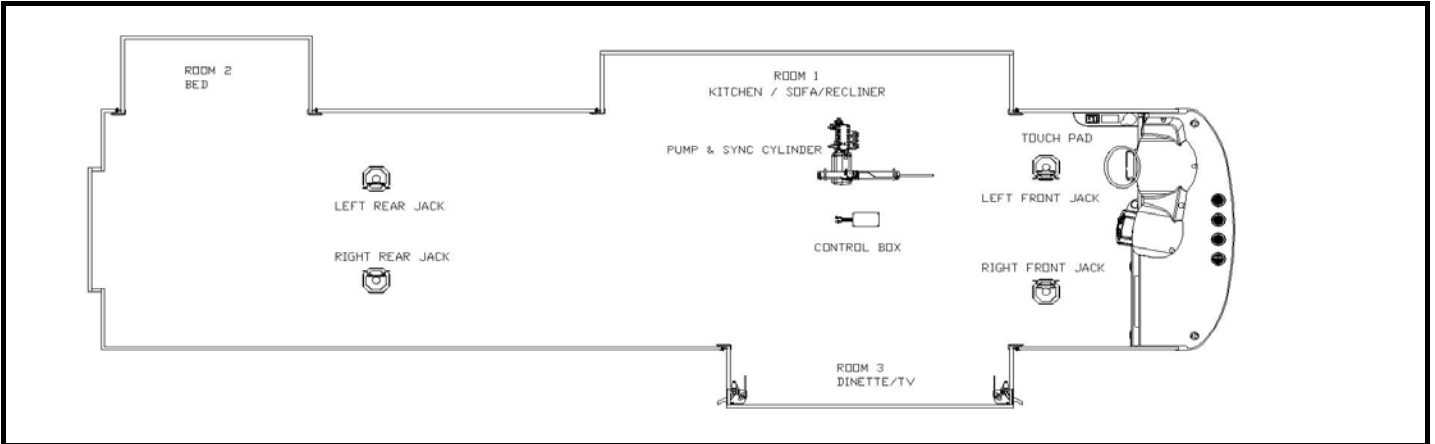

Notes:

1) Jacks mount in two different locations on bracket depending on tire size of chassis.

a) 19.5 Tires: Top hole in jack to top hole in bracket. Use 4 bolts in welded area of bracket.

b) 22.5 Tires: Top hole in jack to second hole in bracket. Use 6 bolts, 4 in welded area of bracket & 2 below welded area.

c) Hydraulic hose terminations for room #3 require 90 degree swivel elbows.

Item, Length	Description / Location	Qty	Color	Vendor PN	Measuring from inside of
Kit	(Items listed below)	1		8342	
Pump	7-Function, 3 Rooms & Jacks	1		7301BR	
Jack	12,000 lbs, 16" Stroke	4		7214	
Touch Pad	Located to the left of the drivers seat	1		2318	
Control Box	Attached to bottom of structure	1		2730	
Sync Cylinder	Mounted behind pump compartment	1		7397	
Hose, 120	Pump to Jack, Left Front	2	Brown	2465	
Hose, 240	Pump to Jack, Left Rear	2	Orange	2475	
Hose, 168	Pump to Jack, Right Front	2	White	2469	
Hose, 240	Pump to Jack, Right Rear	2	Yellow	2475	
Hose, 36	Pump to sync cylinder	2	Green	2458	Inside pump compartment
Hose, 120	Sync cylinder to front slide, Room 3	2	Gray	2465	90 / Passenger Side
Hose, 120	Sync cylinder to rear slide, Room 3	2	Gray	2465	145 / Passenger Side
Hose, 36	Pump to Room 1	2	Green	2458	127 / Drivers Side
Hose, 420	Pump to Room 2	2	Purple	2485	335 / Drivers Side
Hose, N/A	Pump to Room 3	N/A	Gray	N/A	N/A
Hose, N/A	Pump to Room 4	N/A	Red	N/A	N/A
Hose, N/A	Pump to Generator Slide	N/A		N/A	N/A
Travel Clamp	Two per Slide	2		HWH	N/A
Options					

**36Z MAGELLAN (22.5) TIRES
EQUALIZER JACKS (FULLY AUTOMATIC)
STANDARD ON THIS UNIT**

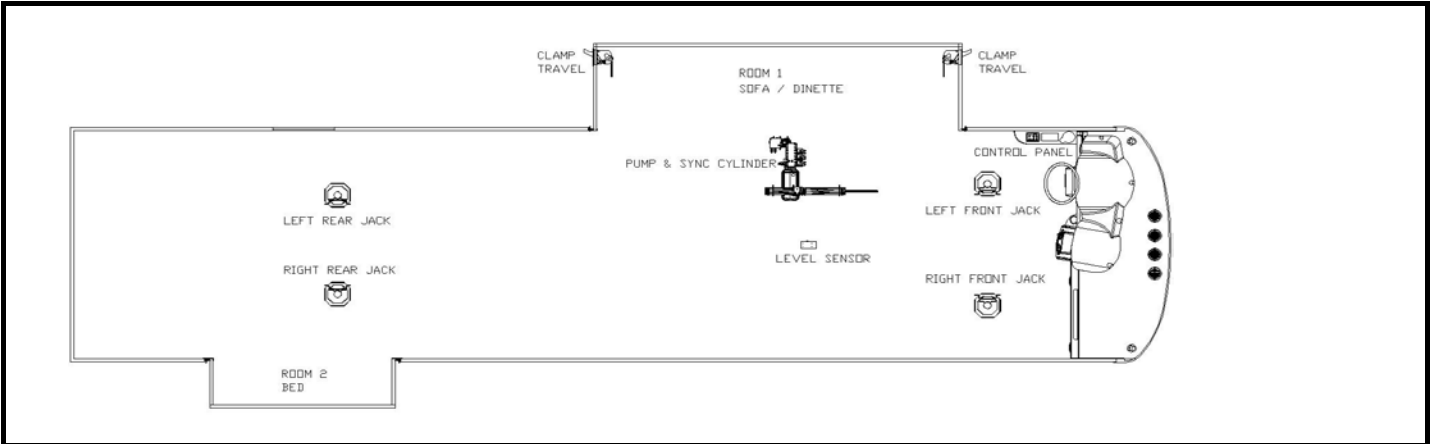

Notes:

- 1) Jacks mount in two different locations on bracket depending on tire size of chassis.
 - a) 19.5 Tires: Top hole in jack to top hole in bracket. Use 4 bolts in welded area of bracket.
 - b) 22.5 Tires: Top hole in jack to second hole in bracket. Use 6 bolts, 4 in welded area of bracket & 2 below welded area.

Item, Length	Description / Location	Qty	Color	Vendor PN	
Kit	(Items listed below)	1		8290	Measuring from inside of firewall, this is the end location of the hydraulic hoses where they attach to the slide mechanism.
Pump	6-Function, 2 Rooms & Jacks	1		7243BR	
Jack	12,000 lbs, 16" Stroke	4		7214	
Touch Pad	Located to the left of the drivers seat	1		2318	
Control Box	Attached to bottom of structure	1		2730	
Sync Cylinder	Mounted behind pump compartment	1		7387	
Hose, 144	Pump to Jack, Left Front	2	Brown	2467	
Hose, 264	Pump to Jack, Left Rear	2	Orange	2476	
Hose, 180	Pump to Jack, Right Front	2	White	2470	
Hose, 300	Pump to Jack, Right Rear	2	Yellow	2479	
Hose, 36	Pump to sync cylinder	2	Green	2458	Inside pump compartment
Hose, 108	Sync cylinder to front slide, Room 1	2	Green	2464	95 / Drivers Side
Hose, 108	Sync cylinder to rear slide, Room 1	2	Green	2464	166 / Drivers Side
Hose, N/A	Pump to Room 1	N/A	Green	N/A	N/A
Hose, 372	Pump to Room 2	2	Purple	2481	319 / Passenger Side
Hose, N/A	Pump to Room 3	N/A	Gray	N/A	N/A
Hose, N/A	Pump to Room 4	N/A	Red	N/A	N/A
Hose, N/A	Pump to Generator Slide	N/A		N/A	N/A
Travel Clamp	Two per Slide	2		HWH	N/A

Options

Item, Length	Description / Location	Qty	Color	Vendor PN	

Revisions

1	Flow divider replaces sync cylinder (addendum to original ECN 3706)
2	Windsport now has it's own chart starting with the schedule released 04/24/06, CH-0149 (MY2007)
3	Chg'd sync cylinder p/n to 7387, was 7351, see ECN-4237 12-8-06

**38E MAGELLAN (22.5) TIRES
EQUALIZER JACKS (FULLY AUTOMATIC)
STANDARD ON THIS UNIT**

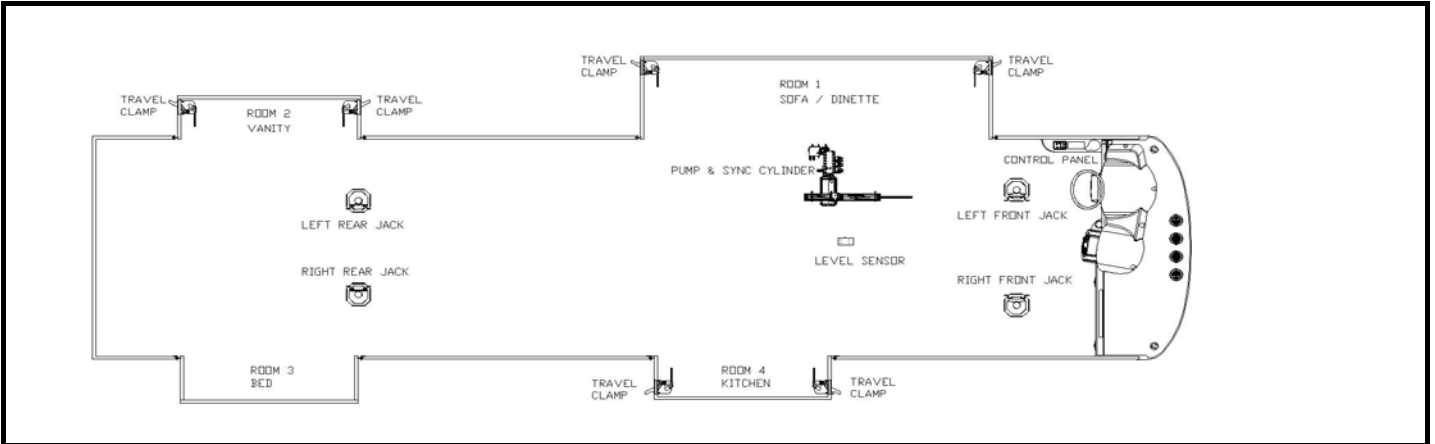

Notes:

- 1) Jacks mount in two different locations on bracket depending on tire size of chassis.
 - a) 19.5 Tires: Top hole in jack to top hole in bracket. Use 4 bolts in welded area of bracket.
 - b) 22.5 Tires: Top hole in jack to second hole in bracket. Use 6 bolts, 4 in welded area of bracket & 2 below welded area.

Item, Length	Description / Location	Qty	Color	Vendor PN		
Kit	(Items listed below)	1		8291	Measuring from inside of firewall, this is the end location of the hydraulic hoses where they attach to the slide mechanism.	
Pump	8-Function, 4 Rooms & Jacks	1		7302BR		
Jack	12,000 lbs, 16" Stroke	4		7214		
Touch Pad	Located to the left of the drivers seat	1		2318		
Control Box	Attached to bottom of structure	1		2730		
Sync Cylinder	Mounted behind pump compartment	1		7387		
Hose, 144	Pump to Jack, Left Front	2	Brown	2467		
Hose, 288	Pump to Jack, Left Rear	2	Orange	2478		
Hose, 180	Pump to Jack, Right Front	2	White	2470		
Hose, 324	Pump to Jack, Right Rear	2	Yellow	2480		
Hose, 36	Pump to sync cylinder	2	Green	2458		Inside pump compartment
Hose, 108	Sync cylinder to front slide, Room 1	2	Green	2464		95 / Drivers Side
Hose, 108	Sync cylinder to rear slide, Room 1	2	Green	2464		166 / Drivers Side
Hose, N/A	Pump to Room 1	N/A	Green	N/A		N/A
Hose, 372	Pump to Room 2	2	Purple	2481	356 / Drivers Side	
Hose, 396	Pump to Room 3	2	Gray	2483	344 / Passenger Side	
Hose w/90, 108	Pump to Room 4	2	Red	2464	160 / Passenger Side	
Hose, N/A	Pump to Generator Slide	N/A		N/A	N/A	
Travel Clamp	Two per Slide	6		HWH	N/A	

Options

Item, Length	Description / Location	Qty	Color	Vendor PN	

Revisions

1	Flow divider replaces sync cylinder, add 90 fitting to "Pump to Room 4" (addendum to original ECN 3706)
2	Windsport now has it's own chart starting with the schedule released 04/24/06, CH-0149 (MY2007)
3	Chg'd sync cylinder p/n to 7387, was 7351, see ECN-4237 12-8-06

39A Presidio
EQUALIZER JACKS (FULLY AUTOMATIC)
STANDARD ON THIS UNIT

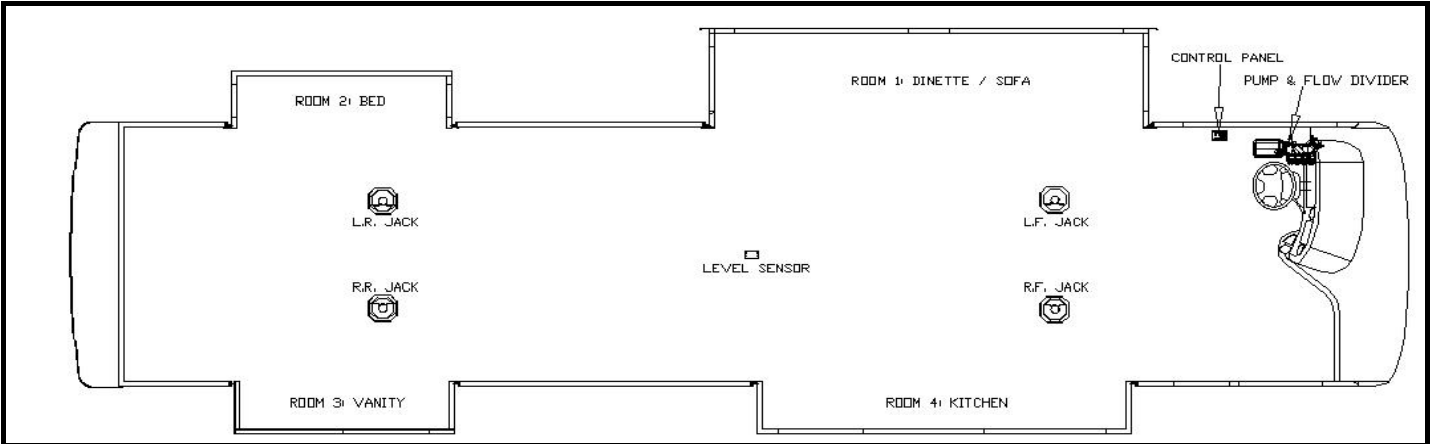

Notes:

- 1) Jacks mount to chassis brackets with the lowest holes of the jacks aligned with the lowest holes of the mounting brackets.
- 2) Level sensor attaches to bottom of structure; on the square tube the runs full length from axle to axle.
- 3) Hydraulic hose terminations for room #1, #3, & #4 require 90 degree swivel elbows.
- 4) Reference FM-3991 for a better visual of Room 1 hydraulic connections.
- 5) Hoses marked w90 will have the 90 deg fitting shipped loose.

Item, Length	Description / Location	Qty	Color	Vendor PN		
Kit	(Items listed below)	1		8294	Measuring from inside of firewall, this is the end location of the hydraulic hoses where they attach to the slide mechanism.	
Pump	8-Function, 4 Rooms & Jacks	1		7302		
Jack	17,000 lbs, 18" Stroke	4		7134		
Touch Pad	Located to the left of the drivers seat	1		2318		
Control Box	Attached to bottom of structure	1		2319		
Sync Cylinder	Mounted behind LP tank	1		7387		
Hose, 144	Pump to Jack, Left Front	2	Brown	2467		
Hose, 396	Pump to Jack, Left Rear	2	Orange	2483		
Hose, 144	Pump to Jack, Right Front	2	White	2467		
Hose, 396	Pump to Jack, Right Rear	2	Yellow	2483		
Hose, 144	Pump to synchronizing cylinder	2	Green	2467		
Hose w90, 168	Sync cylinder to front slide, Room 1	2	Green	2469		103 / Drivers side
Hose w90, 168	Sync cylinder to rear slide, Room 1	2	Green	2469		196 / Drivers side
	Pump to Room 1	N/A	Green			
Hose, 480	Pump to Room 2	2	Purple	2490	340 / Drivers Side	
Hose w90, 432	Pump to Room 3	2	Gray	2486	365 / Passenger Side	
Hose w90, 228	Pump to Room 4	2	Red	2474	146 / Passenger Side	
	Pump to Generator Slide	N/A			N/A	
Travel Clamp	(two per slide, except the bed slide)	6		HWH	N/A	

Options

Revisions

	Beginning with release of 1/23/06 and documented on ECN #3845
1	ECN#4099 Equalizer standardize sizes & renumbers parts, 90 deg fitting ship loose

**38E Presidio
EQUALIZER JACKS (FULLY AUTOMATIC)
STANDARD ON THIS UNIT**

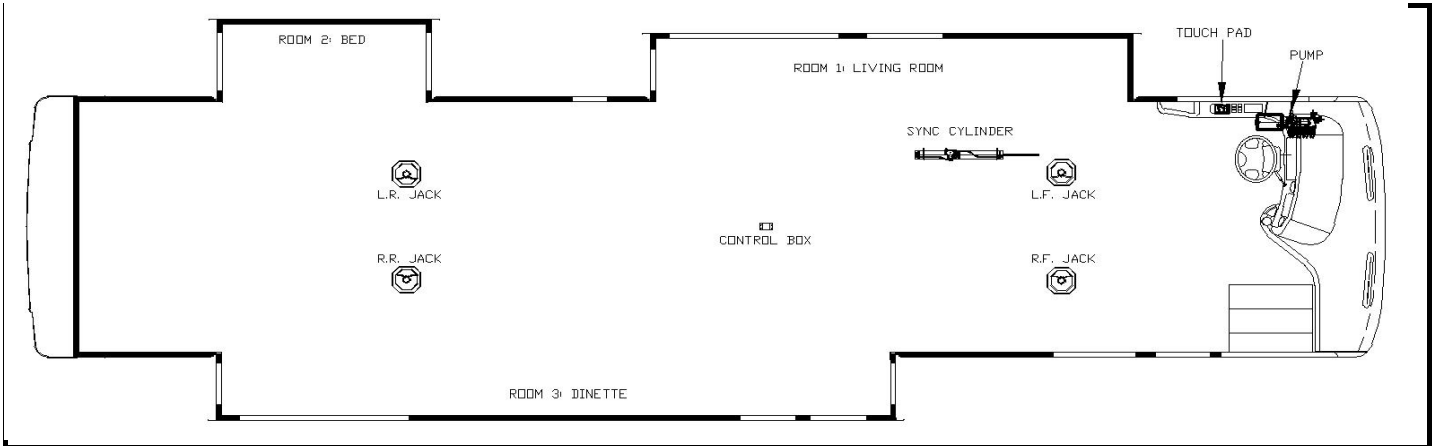

- Notes:**
- 1) Jacks mount to chassis brackets with the lowest holes of the jacks aligned with the lowest holes of the mounting brackets.
 - 2) Level sensor attaches to bottom of structure; on the square tube the runs full length from axle to axle.
 - 3) Hydraulic hose terminations for room #2 & #3 require 90 degree swivel elbows.
 - 4) Room #3 will have a non-powered slide mechanism in center of room
 - 5) Hoses marked w90 will have the 90 deg fitting shipped loose.

Item, Length	Description / Location	Qty	Color	Vendor PN		
Kit	(Items listed below)	1		8350	Measuring from inside of firewall, this is the end location of the hydraulic hoses where they attach to the slide mechanism.	
Pump	7-Function, 4 Rooms & Jacks	1		7319		
Jack	17,000 lbs, 18" Stroke	4		7134		
Touch Pad	Located to the left of the drivers seat	1		2318		
Control Box	Attached to bottom of structure	1		2319		
Sync Cylinder	Mounted behind LP tank	1		7351		
Hose, 144	Pump to Jack, Left Front	2	Brown	2467		
Hose, 396	Pump to Jack, Left Rear	2	Orange	2483		
Hose, 144	Pump to Jack, Right Front	2	White	2467		
Hose, 396	Pump to Jack, Right Rear	2	Yellow	2483		
Hose, 144	Pump to synchronizing cylinder	2	Gray	2467		Mounts to bracket on structure
Hose w90, 432	Sync cylinder to front slide, Room 3	2	Gray	2486		103 / Passenger side
Hose w90, 432	Sync cylinder to rear slide, Room 3	2	Gray	2486		350 / Passenger side
	Pump to Room 1	N/A	Green			
Hose w90, 168	Pump to Room 1	2	Green	2469	146 / Drivers Side	
Hose, 480	Pump to Room 2	2	Purple	2490	345 / Drivers Side	
	Pump to Generator Slide	N/A			N/A	
Travel Clamp	(two per slide, except the bed slide)	4		HWH	N/A	

Options

Revisions

**39B Presidio
EQUALIZER JACKS (FULLY AUTOMATIC)
STANDARD ON THIS UNIT**

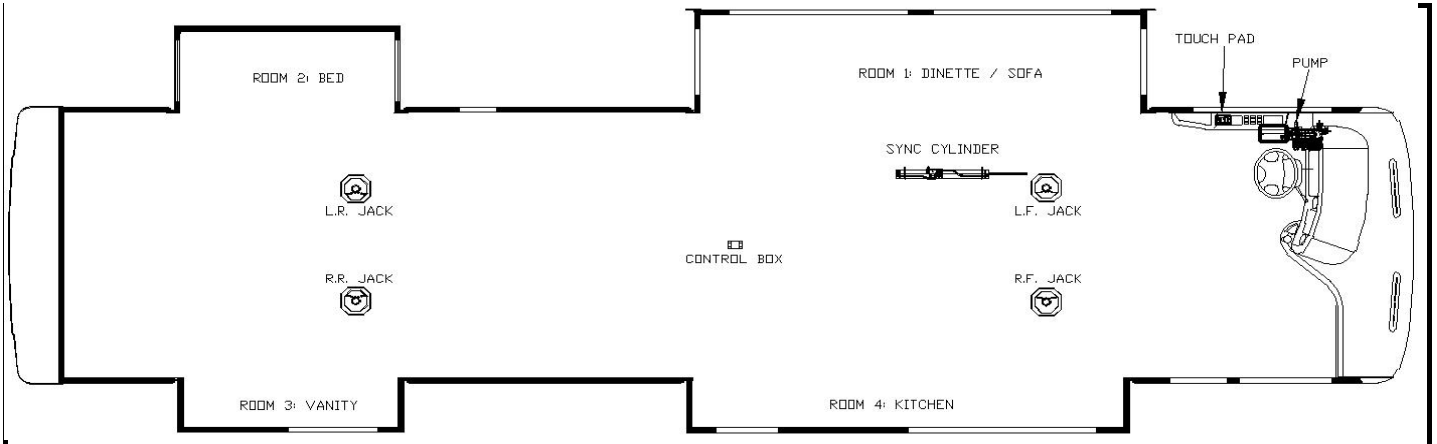

Notes:

- 1) Jacks mount to chassis brackets with the lowest holes of the jacks aligned with the lowest holes of the mounting brackets.
- 2) Level sensor attaches to bottom of structure; on the square tube the runs full length from axle to axle.
- 3) Hydraulic hose terminations for room #1, #3, & #4 require 90 degree swivel elbows.
- 4) Reference FM-3991 for a better visual of Room 1 hydraulic connections.
- 5) Hoses marked w90 will have the 90 deg fitting shipped loose.

Item, Length	Description / Location	Qty	Color	Vendor PN	
Kit	(Items listed below)	1		8294	
Pump	8-Function, 4 Rooms & Jacks	1		7302	Measuring from inside of firewall, this is the end location of the hydraulic hoses where they attach to the slide mechanism.
Jack	17,000 lbs, 18" Stroke	4		7134	
Touch Pad	Located to the left of the drivers seat	1		2318	
Control Box	Attached to bottom of structure	1		2319	
Sync Cylinder	Mounted behind LP tank	1		7387	
Hose, 144	Pump to Jack, Left Front	2	Brown	2467	
Hose, 396	Pump to Jack, Left Rear	2	Orange	2483	
Hose, 144	Pump to Jack, Right Front	2	White	2467	
Hose, 396	Pump to Jack, Right Rear	2	Yellow	2483	
Hose, 144	Pump to synchronizing cylinder	2	Green	2467	
Hose w90, 168	Sync cylinder to front slide, Room 1	2	Green	2469	103 / Drivers side
Hose w90, 168	Sync cylinder to rear slide, Room 1	2	Green	2469	196 / Drivers side
	Pump to Room 1	N/A	Green		
Hose, 480	Pump to Room 2	2	Purple	2490	340 / Drivers Side
Hose w90, 432	Pump to Room 3	2	Gray	2486	365 / Passenger Side
Hose w90, 228	Pump to Room 4	2	Red	2474	155 / Passenger Side
	Pump to Generator Slide	N/A			N/A
Travel Clamp	(two per slide, except the bed slide)	6		HWH	N/A

Options

Item, Length	Description / Location	Qty	Color	Vendor PN	

Revisions

	Beginning with release of 1/23/06 and documented on ECN #3845
1	ECN#4099 Equalizer standardize sizes & renumbers parts, 90 deg fitting ship loose
2	UPDATE JPG
3	Updated per ECN #4237

**39C Presidio
EQUALIZER JACKS (FULLY AUTOMATIC)
STANDARD ON THIS UNIT**

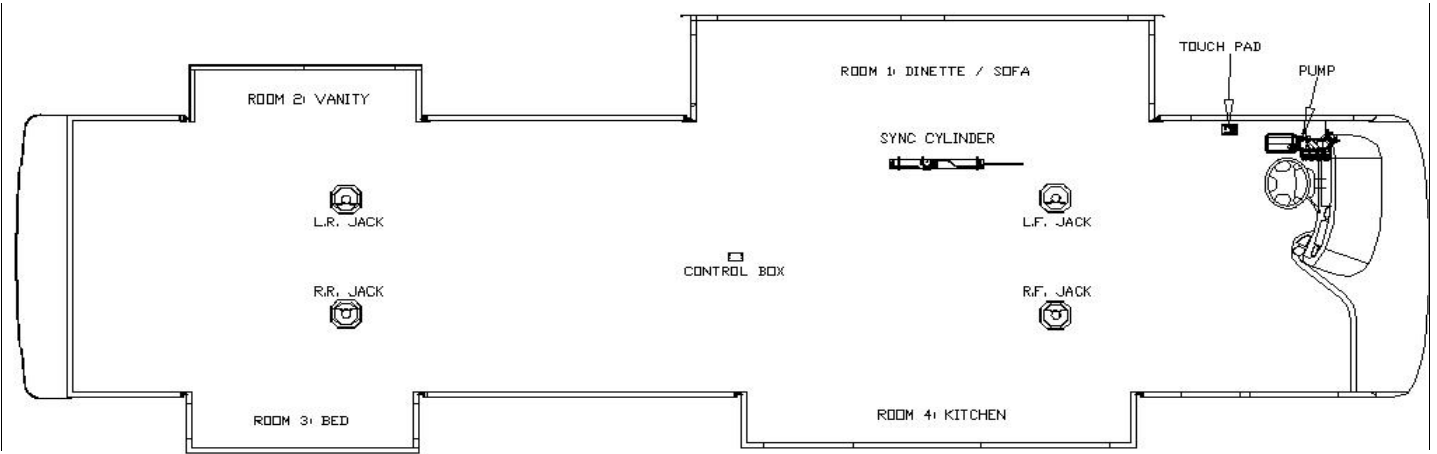

Notes:

- 1) Jacks mount to chassis brackets with the lowest holes of the jacks aligned with the lowest holes of the mounting brackets.
- 2) Level sensor attaches to bottom of structure; on the square tube the runs full length from axle to axle.
- 3) Hydraulic hose terminations for room #1, #2, & #4 require 90 degree swivel elbows.
- 4) Reference FM-3991 for a better visual of Room 1 hydraulic connections.
- 5) Hoses marked w90 will have the 90 deg fitting shipped loose.

Item, Length	Description / Location	Qty	Color	Vendor PN		
Kit	(Items listed below)	1		8293	Measuring from inside of firewall, this is the end location of the hydraulic hoses where they attach to the slide mechanism.	
Pump	8-Function, 4 Rooms & Jacks	1		7302		
Jack	17,000 lbs, 18" Stroke	4		7134		
Touch Pad	Located to the left of the drivers seat	1		2318		
Control Box	Attached to bottom of structure	1		2319		
Sync Cylinder	Mounted behind LP tank	1		7387		
Hose, 144	Pump to Jack, Left Front	2	Brown	2467		
Hose, 396	Pump to Jack, Left Rear	2	Orange	2483		
Hose, 144	Pump to Jack, Right Front	2	White	2467		
Hose, 396	Pump to Jack, Right Rear	2	Yellow	2483		
Hose, 144	Pump to synchronizing cylinder	2	Green	2467		Mounts to bracket on structure
Hose w90, 168	Sync cylinder to front slide, Room 1	2	Green	2469		103 / Drivers side
Hose w90, 168	Sync cylinder to rear slide, Room 1	2	Green	2469		196 / Drivers side
	Pump to Room 1	N/A	Green			
Hose w90, 432	Pump to Room 2	2	Purple	2486	350 / Drivers Side	
Hose, 480	Pump to Room 3	2	Gray	2490	345 / Passenger Side	
Hose w90, 228	Pump to Room 4	2	Red	2474	146 / Passenger Side	
	Pump to Generator Slide	N/A			N/A	
Travel Clamp	(two per slide, except the bed slide)	6		HWH	N/A	

Options

Revisions

	Beginning with release of 1/23/06 and documented on ECN #3845
1	ECN#4099 Equalizer standardize sizes & renumbers parts, 90 deg fitting ship loose
2	UPDATE JPG
3	Updated per ECN #4237

39D Presidio
EQUALIZER JACKS (FULLY AUTOMATIC)
STANDARD ON THIS UNIT

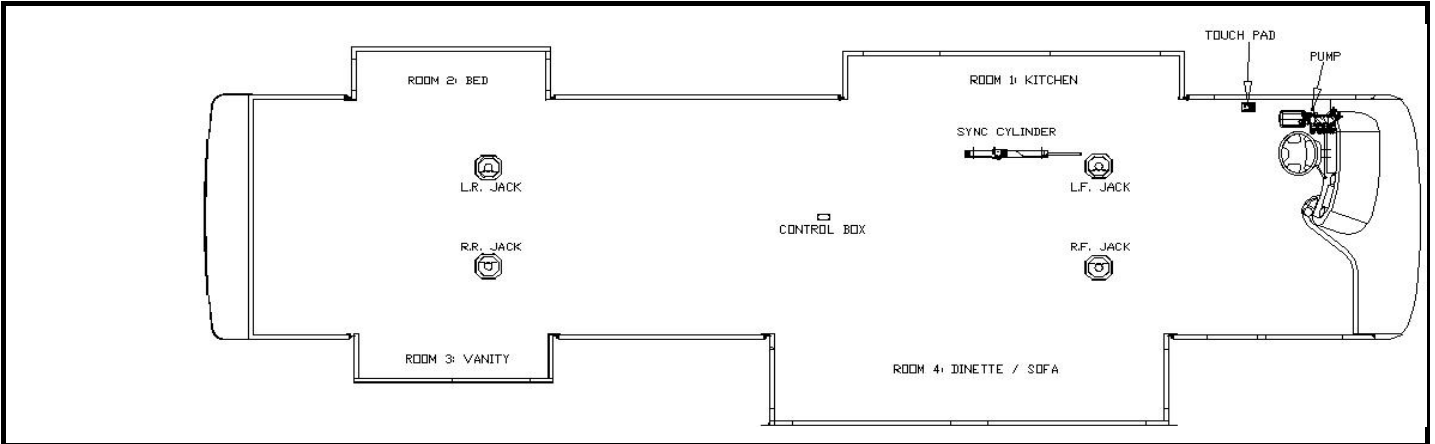

Notes:

- 1) Jacks mount to chassis brackets with the lowest holes of the jacks aligned with the lowest holes of the mounting brackets.
- 2) Level sensor attaches to bottom of structure; on the square tube the runs full length from axle to axle.
- 3) Hydraulic hose terminations for room #1, #3, & #4 require 90 degree swivel elbows.
- 4) Reference FM-3991 for a better visual of Room 4 hydraulic connections.
- 5) Hoses marked w90 will have the 90 deg fitting shipped loose.

Item, Length	Description / Location	Qty	Color	Vendor PN		
Kit	(Items listed below)	1		8292	Measuring from inside of firewall, this is the end location of the hydraulic hoses where they attach to the slide mechanism.	
Pump	8-Function, 4 Rooms & Jacks	1		7302		
Jack	17,000 lbs, 18" Stroke	4		7134		
Touch Pad	Located to the left of the drivers seat	1		2318		
Control Box	Attached to bottom of structure	1		2319		
Sync Cylinder	Mounted behind LP tank	1		7387		
Hose, 144	Pump to Jack, Left Front	2	Brown	2467		
Hose, 396	Pump to Jack, Left Rear	2	Orange	2483		
Hose, 144	Pump to Jack, Right Front	2	White	2467		
Hose, 396	Pump to Jack, Right Rear	2	Yellow	2483		
Hose, 144	Pump to synchronizing cylinder	2	Red	2467		Mounts to bracket on structure
Hose w90, 168	Pump to Room 1	2	Green	2469		149 / Drivers side
Hose, 480	Pump to Room 2	2	Purple	2490		325 / Drivers Side
Hose w90, 432	Pump to Room 3	2	Gray	2486	355 / Passenger Side	
Hose w90, 168	Sync cylinder to front slide, Room 4	2	Red	2469	103 / Passenger side	
Hose w90, 168	Sync cylinder to rear slide, Room 4	2	Red	2469	196 / Passenger side	
	Pump to Generator Slide	N/A			N/A	
Travel Clamp	(two per slide, except the bed slide)	6		HWH	N/A	
Options						
Revisions						
	Beginning with release of 1/23/06 and documented on ECN #3845					
1	Equalizer lengthened hose....part #2415 (was too short per S. Jung email on 4/27)					
2	ECN#4099 Equalizer standardize sizes & renumbers parts, 90 deg fitting ship loose					
3	UPDATE JPG					

**39E Presidio
EQUALIZER JACKS (FULLY AUTOMATIC)
STANDARD ON THIS UNIT**

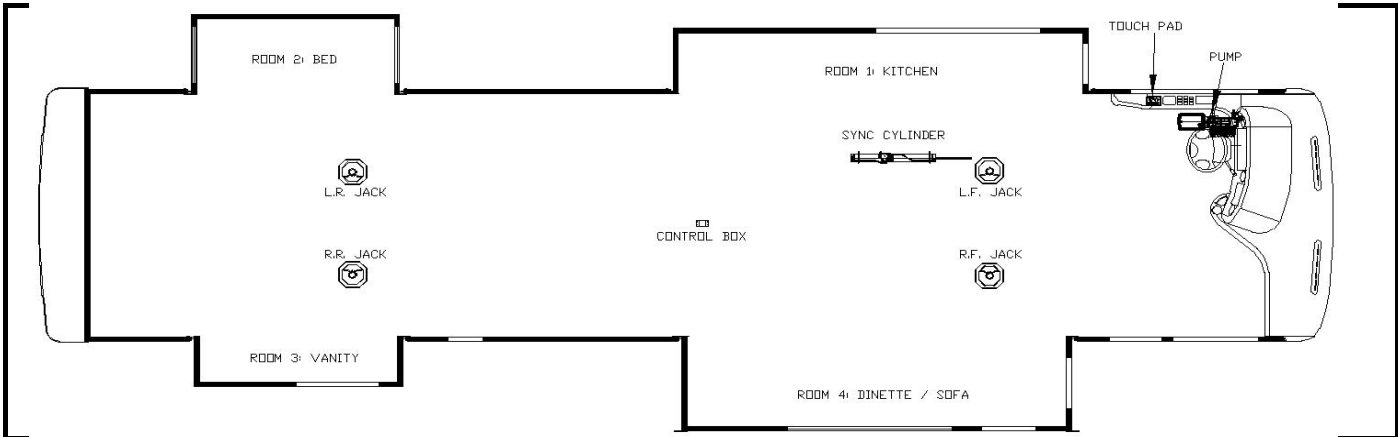

Notes:

- 1) Jacks mount to chassis brackets with the lowest holes of the jacks aligned with the lowest holes of the mounting brackets.
- 2) Level sensor attaches to bottom of structure; on the square tube the runs full length from axle to axle.
- 3) Hydraulic hose terminations for room #1, #3, & #4 require 90 degree swivel elbows.
- 4) Reference FM-3991 for a better visual of Room 4 hydraulic connections.
- 5) Hoses marked w90 will have the 90 deg fitting shipped loose.

Item, Length	Description / Location	Qty	Color	Vendor PN	
Kit	(Items listed below)	1		8315	Measuring from inside of firewall, this is the end location of the hydraulic hoses where they attach to the slide mechanism. Mounts to bracket on structure Mounts to bracket on structure 325 / Drivers Side 355 / Passenger Side 95 / Drivers Side 180 / Drivers Side 103 / Passenger side 196 / Passenger side N/A N/A
Pump	8-Function, 4 Rooms & Jacks	1		7302	
Jack	17,000 lbs, 18" Stroke	4		7134	
Touch Pad	Located to the left of the drivers seat	1		2318	
Control Box	Attached to bottom of structure	1		2319	
Sync Cylinder	Mounted behind LP tank	1		7387	
Hose, 144	Pump to Jack, Left Front	2	Brown	2467	
Hose, 396	Pump to Jack, Left Rear	2	Orange	2483	
Hose, 144	Pump to Jack, Right Front	2	White	2467	
Hose, 396	Pump to Jack, Right Rear	2	Yellow	2483	
Hose, 144	Pump to synchronizing cylinder	2	Green	2467	
Hose, 144	Pump to synchronizing cylinder	2	Red	2467	
Hose, 480	Pump to Room 2	2	Purple	2490	
Hose w90, 432	Pump to Room 3	2	Gray	2486	
Hose w90, 168	Sync cylinder to front slide, Room 1	2	Green	2469	
Hose w90, 168	Sync cylinder to rear slide, Room 1	2	Green	2469	
Hose w90, 168	Sync cylinder to front slide, Room 4	2	Red	2469	
Hose w90, 168	Sync cylinder to rear slide, Room 4	2	Red	2469	
	Pump to Generator Slide	N/A			
Travel Clamp	(two per slide, except the bed slide)	6		HWH	
Sync Cylinder	Mounted behind LP tank	1		7351	

Options

Revisions

1	ECN#4099 Equalizer standardize sizes & renumbers parts, 90 deg fitting ship loose
2	UPDATE JPG
3	Updated per ECN #4237

**39F Presidio
EQUALIZER JACKS (FULLY AUTOMATIC)
STANDARD ON THIS UNIT**

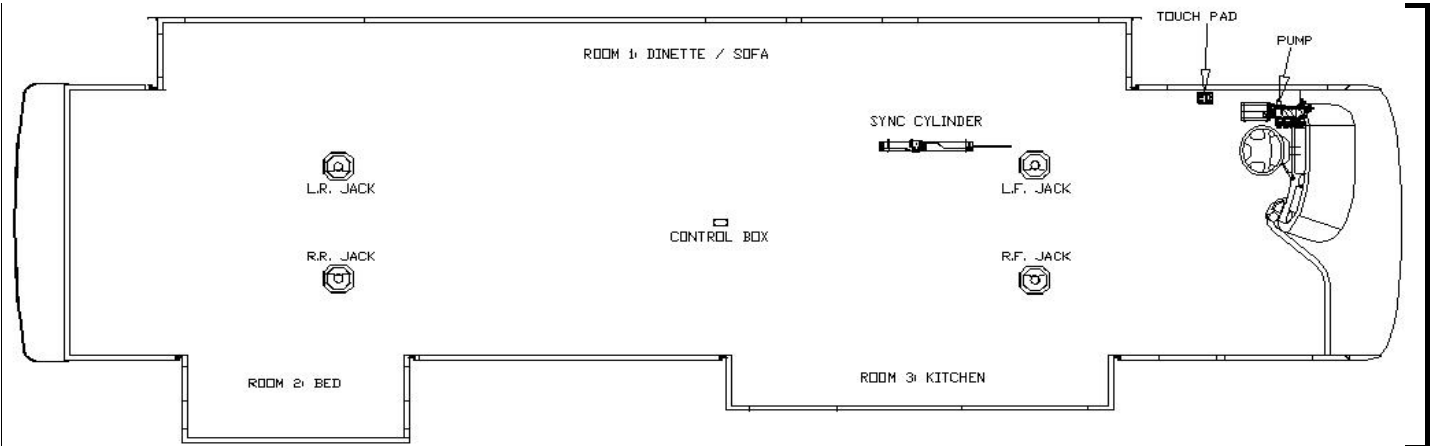

Notes:

- 1) Jacks mount to chassis brackets with the lowest holes of the jacks aligned with the lowest holes of the mounting brackets.
- 2) Level sensor attaches to bottom of structure; on the square tube the runs full length from axle to axle.
- 3) Hydraulic hose terminations for room #1 & #2 require 90 degree swivel elbows.
- 4) Room #1 will have a non-powered slide mechanism in center of room
- 5) Hoses marked w90 will have the 90 deg fitting shipped loose.

Item, Length	Description / Location	Qty	Color	Vendor PN		
Kit	(Items listed below)	1		8340	Measuring from inside of firewall, this is the end location of the hydraulic hoses where they attach to the slide mechanism.	
Pump	7-Function, 4 Rooms & Jacks	1		7319		
Jack	17,000 lbs, 18" Stroke	4		7134		
Touch Pad	Located to the left of the drivers seat	1		2318		
Control Box	Attached to bottom of structure	1		2319		
Sync Cylinder	Mounted behind LP tank	1		7351		
Hose, 144	Pump to Jack, Left Front	2	Brown	2467		
Hose, 396	Pump to Jack, Left Rear	2	Orange	2483		
Hose, 144	Pump to Jack, Right Front	2	White	2467		
Hose, 396	Pump to Jack, Right Rear	2	Yellow	2483		
Hose, 144	Pump to synchronizing cylinder	2	Green	2467		Mounts to bracket on structure
Hose w90, 168	Sync cylinder to front slide, Room 1	2	Green	2486		103 / Drivers side
Hose w90, 432	Sync cylinder to rear slide, Room 1	2	Green	2486		350 / Drivers side
Hose, 480	Pump to Room 2	2	Purple	2490	345 / Passenger Side	
Hose w90, 228	Pump to Room 3	2	Gray	2474	146 / Passenger Side	
	Pump to Generator Slide	N/A			N/A	
Travel Clamp	(two per slide, except the bed slide)	4		HWH	N/A	

Options

Revisions

1	UPDATE JPG
2	Updated per ECN #4237

**39G Presidio
EQUALIZER JACKS (FULLY AUTOMATIC)
STANDARD ON THIS UNIT**

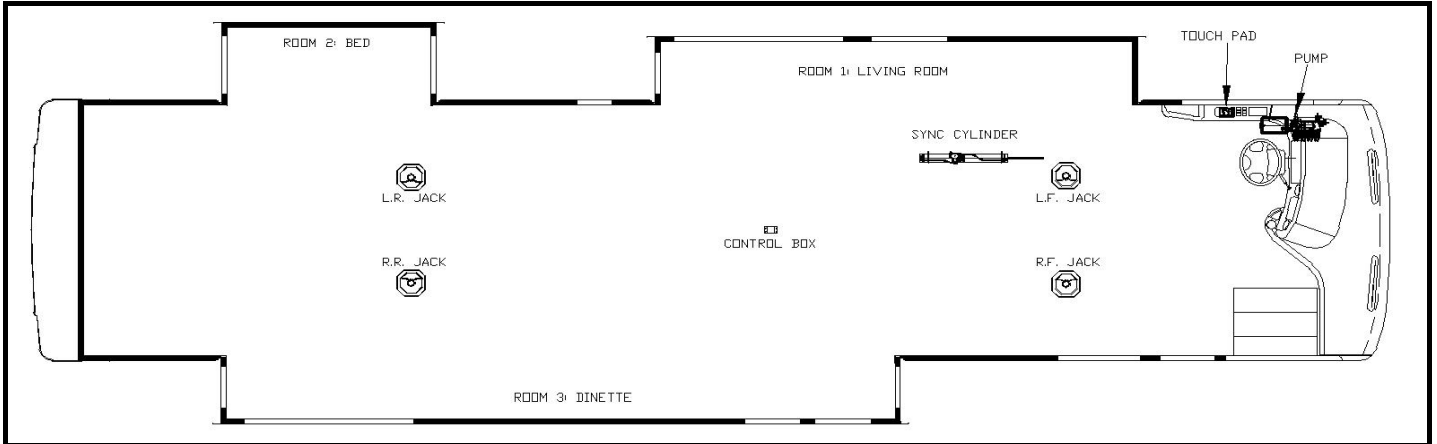

- Notes:**
- 1) Jacks mount to chassis brackets with the lowest holes of the jacks aligned with the lowest holes of the mounting brackets.
 - 2) Level sensor attaches to bottom of structure; on the square tube the runs full length from axle to axle.
 - 3) Hydraulic hose terminations for room #1 & #2 require 90 degree swivel elbows.
 - 4) Room #1 will have a non-powered slide mechanism in center of room
 - 5) Hoses marked w90 will have the 90 deg fitting shipped loose.

Item, Length	Description / Location	Qty	Color	Vendor PN		
Kit	(Items listed below)	1		8354	Measuring from inside of firewall, this is the end location of the hydraulic hoses where they attach to the slide mechanism.	
Pump	7-Function, 3 Rooms & Jacks	1		7319		
Jack	17,000 lbs, 18" Stroke	4		7134		
Touch Pad	Located to the left of the drivers seat	1		2318		
Control Box	Attached to bottom of structure	1		2319		
Sync Cylinder	Mounted behind LP tank	2		7351		
Hose, 144	Pump to Jack, Left Front	2	Brown	2467		
Hose, 408	Pump to Jack, Left Rear	2	Orange	2484		
Hose, 144	Pump to Jack, Right Front	2	White	2467		
Hose, 408	Pump to Jack, Right Rear	2	Yellow	2484		
Hose, 144	Pump to synchronizing cylinder	2	Green	2467		Mounts to bracket on structure
Hose w90, 168	Sync cylinder to front slide, Room 1	2	Green	2469		103 / Drivers side
Hose w90, 168	Sync cylinder to rear slide, Room 1	2	Green	2469		205 / Drivers side
Hose w90, 360	Sync cylinder to front slide, Room 3	2	Gray	2527		205 / Passenger side
Hose w90, 360	Sync cylinder to rear slide, Room 3	2	Gray	2527	350 / Passenger side	
Hose, 480	Pump to Room 2	2	Purple	2490	345 / Drivers Side	
Hose, 144	Pump to synchronizing cylinder	2	Gray	2467	Mounts to bracket on structure	
	Pump to Generator Slide	N/A			N/A	
Travel Clamp	(two per slide, except the bed slide)	4		HWH	N/A	

Options

Revisions

1	Corrected picture
2	Corrected hose notes for room #3 & #1.....2-5-07

**36B Presidio
EQUALIZER JACKS (FULLY AUTOMATIC)
STANDARD ON THIS UNIT**

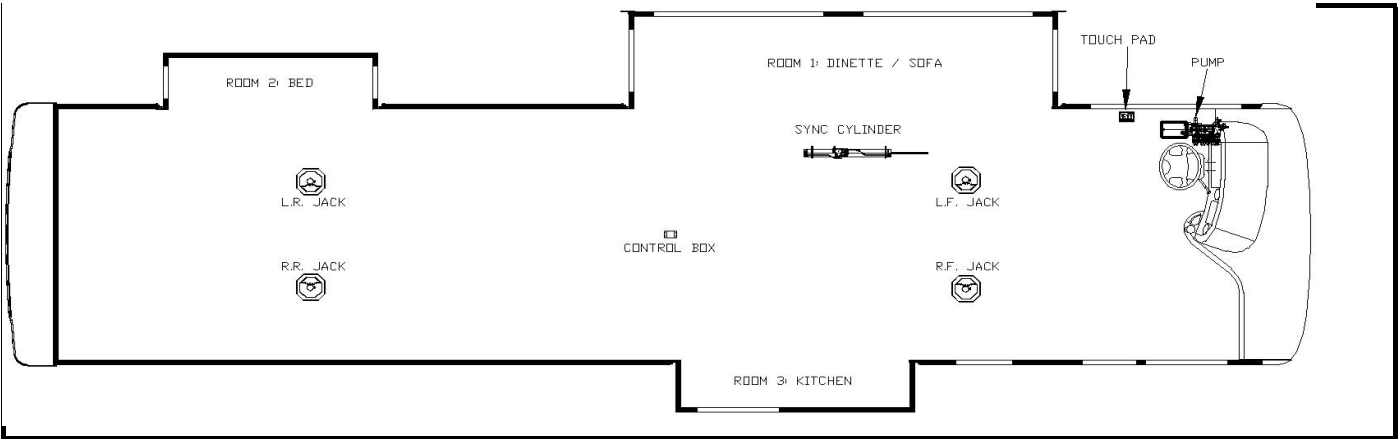

- Notes:**
- 1) Jacks mount to chassis brackets with the lowest holes of the jacks aligned with the lowest holes of the mounting brackets.
 - 2) Level sensor attaches to bottom of structure; on lower hat section flanges or square tube.
 - 3) Hydraulic hose terminations for room #1 & #3 require 90 degree swivel elbows.
 - 4) Reference FM-3991 for a better visual of Room 1 hydraulic connections.
 - 5) Hoses marked w90 will have the 90 deg fitting shipped loose.

Item, Length	Description / Location	Qty	Color	Vendor PN	
Kit	(Items listed below)	1		8310	
Pump	7-Function, 3 Rooms & Jacks	1		7319	
Jack	17,000 lbs, 18" Stroke	4		7134	
Touch Pad	Located to the left of the drivers seat	1		2318	
Control Box	Attached to bottom of structure	1		2319	
Sync Cylinder	Mounted behind LP tank	1		7387	
Hose, 132	Pump to Jack, Left Front	2	Brown	2466	
Hose, 372	Pump to Jack, Left Rear	2	Orange	2481	
Hose, 144	Pump to Jack, Right Front	2	White	2467	
Hose, 372	Pump to Jack, Right Rear	2	Yellow	2481	
Hose, 144	Pump to synchronizing manifold	2	Green	2467	Mounts to bracket on structure
Hose w90, 168	Sync cylinder to front slide, Room 1	2	Green	2469	103 / Drivers side
Hose w90, 168	Sync cylinder to rear slide, Room 1	2	Green	2469	196 / Drivers side
	Pump to Room 1	N/A	Green		
Slide Unit	Room 1 - 36" flush floor slide	2		7164D	
Hose, 420	Pump to Room 2	2	Purple	2485	325 / Drivers Side
Slide Unit	Room 2 - 30" Bed slide (Lippert)	1		143960	
Hose w90, 204	Pump to Room 3	2	Red	2472	146 / Passenger Side
Slide Unit	Room 3 - 18" above floor slide	1		7135	
	Pump to Generator Slide	N/A			N/A
Travel Clamp	(two per slide, except the bed slide)	4		HWH	N/A

Measuring from inside of firewall, this is the end location of the hydraulic hoses where they attach to the slide mechanism.

Options					

Revisions					
1	Added equalizer slide units to chart	ECN# 4438			

**38C Presidio
EQUALIZER JACKS (FULLY AUTOMATIC)
STANDARD ON THIS UNIT**

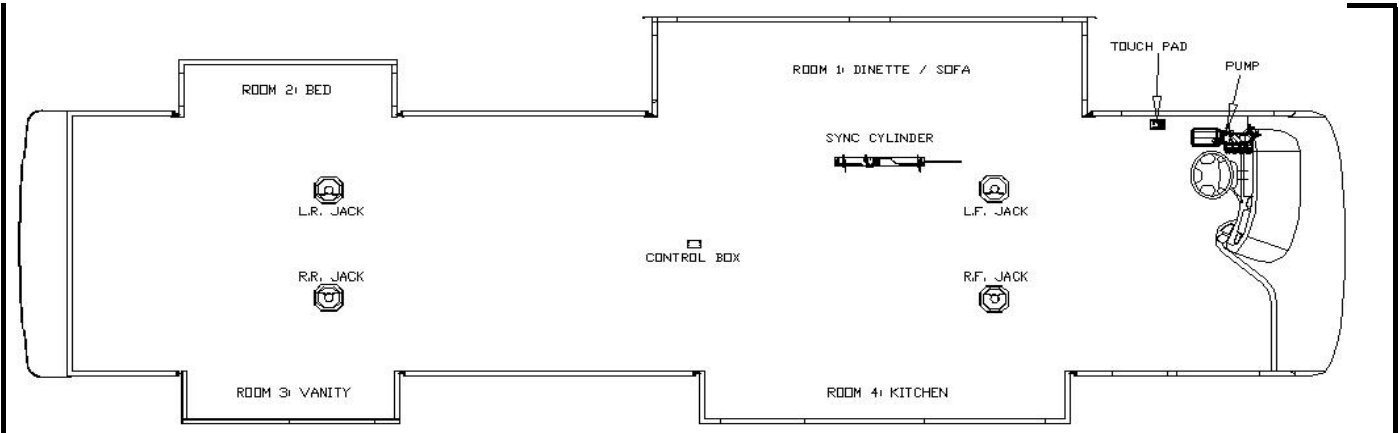

Notes:

- 1) Jacks mount to chassis brackets with the lowest holes of the jacks aligned with the lowest holes of the mounting brackets.
- 2) Level sensor attaches to bottom of structure; on lower hat section flanges or square tube.
- 3) Hydraulic hose terminations for room #1, #3, & #4 require 90 degree swivel elbows.
- 4) Reference FM-3991 for a better visual of Room 1 hydraulic connections.
- 5) Hoses marked w90 will have the 90 deg fitting shipped loose.

Item, Length	Description / Location	Qty	Color	Vendor PN	
Kit	(Items listed below)	1		8278	
Pump	8-Function, 4 Rooms & Jacks	1		7302	
Jack	17,000 lbs, 18" Stroke	4		7134	
Touch Pad	Located to the left of the drivers seat	1		2318	
Control Box	Attached to bottom of structure	1		2319	
Sync Cylinder	Mounted behind LP tank	1		7387	
Hose, 132	Pump to Jack, Left Front	2	Brown	2466	
Hose, 372	Pump to Jack, Left Rear	2	Orange	2481	
Hose, 144	Pump to Jack, Right Front	2	White	2467	
Hose, 372	Pump to Jack, Right Rear	2	Yellow	2481	
Hose, 144	Pump to synchronizing manifold	2	Green	2467	
Hose w90, 168	Sync cylinder to front slide, Room 1	2	Green	2469	Mounts to bracket on structure 103 / Drivers side
Hose w90, 168	Sync cylinder to rear slide, Room 1	2	Green	2469	196 / Drivers side
	Pump to Room 1	N/A	Green		
Slide Unit	Room 1 - 36" flush floor slide	2		7164D	
Hose, 420	Pump to Room 2	2	Purple	2485	325 / Drivers Side
Slide Unit	Room 2 - 30" Bed slide (Lippert)	1		143960	
Hose w90, 456	Pump to Room 3	2	Gray	2488	355 / Passenger Side
Slide Unit	Room 3 - 18" above floor slide	1		7135	
Hose w90, 204	Pump to Room 4	2	Red	2472	146 / Passenger Side
Slide Unit	Room 4 - 18" above floor slide	1		7135	
	Pump to Generator Slide	N/A			N/A
Travel Clamp	(two per slide, except the bed slide)	6		HWH	N/A

Options

Item, Length	Description / Location	Qty	Color	Vendor PN	

Revisions

1	Added equalizer slide units to chart ECN# 4438

**38D Presidio
EQUALIZER JACKS (FULLY AUTOMATIC)
STANDARD ON THIS UNIT**

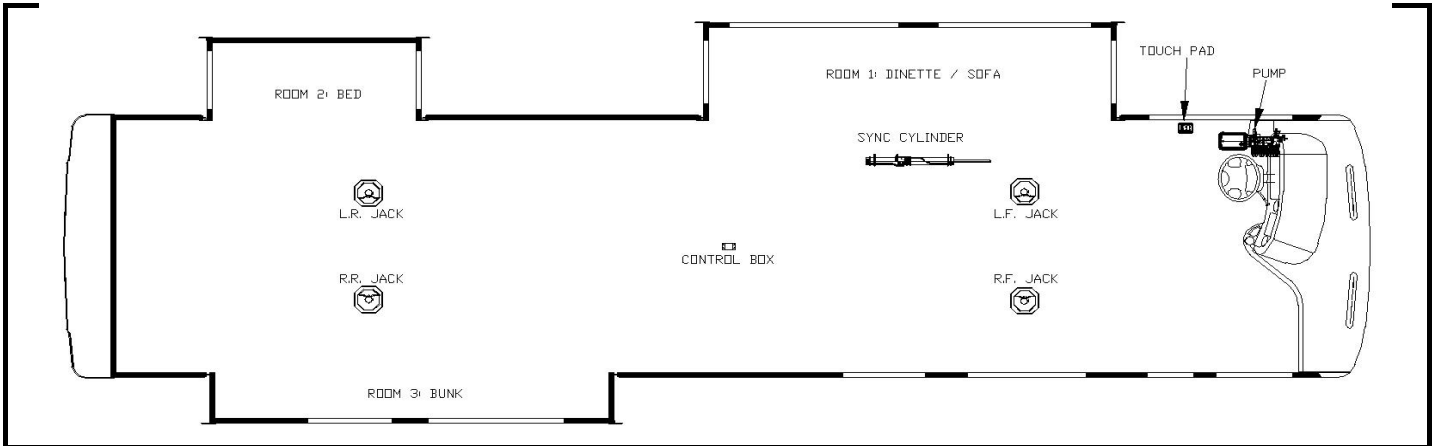

Notes:

- 1) Jacks mount to chassis brackets with the lowest holes of the jacks aligned with the lowest holes of the mounting brackets.
- 2) Level sensor attaches to bottom of structure; on lower hat section flanges or square tube.
- 3) Hydraulic hose terminations for room #1 & #3 require 90 degree swivel elbows.
- 4) Reference FM-3991 for a better visual of Room 1 hydraulic connections.
- 5) Hoses marked w90 will have the 90 deg fitting shipped loose.

Item, Length	Description / Location	Qty	Color	Vendor PN		
Kit	(Items listed below)	1		8347	Measuring from inside of firewall, this is the end location of the hydraulic hoses where they attach to the slide mechanism.	
Pump	7-Function, 3 Rooms & Jacks	1		7319		
Jack	17,000 lbs, 18" Stroke	4		7134		
Touch Pad	Located to the left of the drivers seat	1		2318		
Control Box	Attached to bottom of structure	1		2319		
Sync Cylinder	Mounted behind LP tank	1		7387		
Hose, 132	Pump to Jack, Left Front	2	Brown	2466		
Hose, 372	Pump to Jack, Left Rear	2	Orange	2481		
Hose, 144	Pump to Jack, Right Front	2	White	2467		
Hose, 372	Pump to Jack, Right Rear	2	Yellow	2481		
Hose, 144	Pump to synchronizing manifold	2	Green	2467		Mounts to bracket on structure
Hose w90, 168	Sync cylinder to front slide, Room 1	2	Green	2469		103 / Drivers side
Hose w90, 168	Sync cylinder to rear slide, Room 1	2	Green	2469		196 / Drivers side
	Pump to Room 1	N/A	Green			
Slide Unit	Room 1 - 36" flush floor slide	2		7164D		
Hose, 420	Pump to Room 2	2	Purple	2485	325 / Drivers Side	
Slide Unit	Room 2 - 30" Bed slide (Lippert)	1		143960		
Hose w90, 456	Pump to Room 3	2	Gray	2488	355 / Passenger Side	
Slide Unit	Room 3 - 18" above floor slide	1		7135		
	Pump to Generator Slide	N/A				
Travel Clamp	(two per slide, dinette / sofa slide only)	2		HWH	N/A	

Options

Revisions

1	Added equalizer slide units to chart ECN# 4438

**38E Presidio
EQUALIZER JACKS (FULLY AUTOMATIC)
STANDARD ON THIS UNIT**

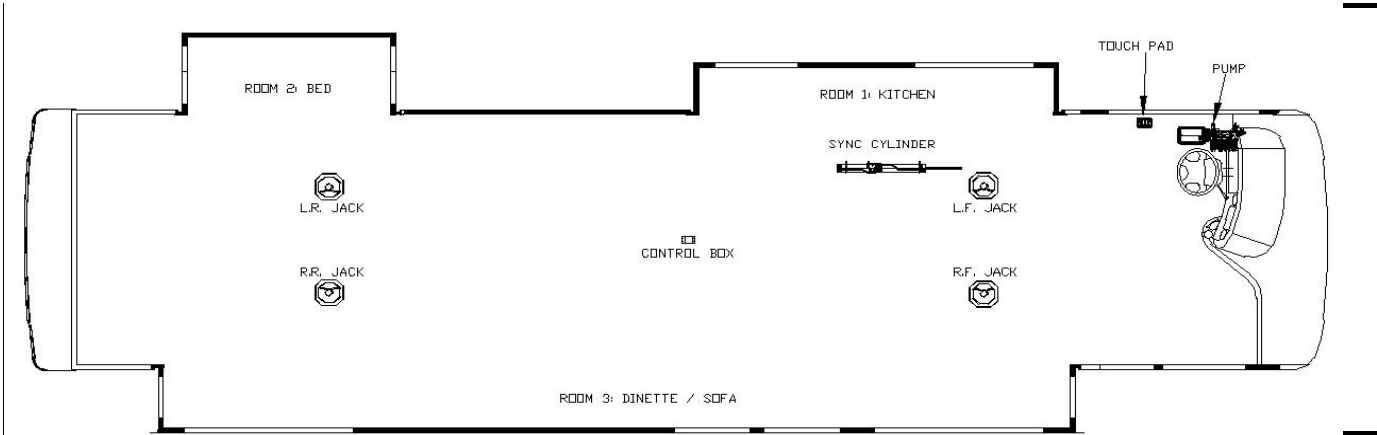

- 1) Jacks mount to chassis brackets with the lowest holes of the jacks aligned with the lowest holes of the mounting brackets.
- 2) Level sensor attaches to bottom of structure; on the square tube the runs full length from axle to axle.
- 3) Hydraulic hose terminations for room #2 & #3 require 90 degree swivel elbows.
- 4) Room #3 will have a non-powered slide mechanism in center of room
- 5) Hoses marked w90 will have the 90 deg fitting shipped loose.

Item, Length	Description / Location	Qty	Color	Vendor PN		
Kit	(Items listed below)	1		8350	Measuring from inside of firewall, this is the end location of the hydraulic hoses where they attach to the slide mechanism.	
Pump	8-Function, 4 Rooms & Jacks	1		7302		
Jack	17,000 lbs, 18" Stroke	4		7134		
Touch Pad	Located to the left of the drivers seat	1		2318		
Control Box	Attached to bottom of structure	1		2319		
Sync Cylinder	Mounted behind LP tank	1		7397		
Hose, 144	Pump to Jack, Left Front	2	Brown	2467		
Hose, 396	Pump to Jack, Left Rear	2	Orange	2483		
Hose, 144	Pump to Jack, Right Front	2	White	2467		
Hose, 396	Pump to Jack, Right Rear	2	Yellow	2483		
Hose, 144	Pump to synchronizing cylinder	2	Green	2467		Mounts to bracket on structure
Hose w90, 168	Sync cylinder to front slide, Room 3	2	Green	2469		103 / Drivers side
Hose w90, 432	Sync cylinder to rear slide, Room 3	2	Green	2486		350 / Drivers side
Slide Unit	Room 3 - 24" flush floor slide (angled)	2		7388		
Slide Unit	Room 3 - 24" flush floor slide (angled)	1		7384		Slave
	Pump to Room 1	N/A	Green			
Hose w90, 168	Pump to Room 1	2	Green	2469	146 / Passenger Side	
Slide Unit	Room 1 - 18" above floor slide	1		7135		
Hose, 480	Pump to Room 2	2	Gray	2490	345 / Drivers Side	
Slide Unit	Room 2 - 30" Bed slide (Lippert)	1		143960		
	Pump to Generator Slide	N/A			N/A	
Travel Clamp	(two per slide, except the bed slide)	4		HWH	N/A	
Options						

Revisions					
1	Added equalizer slide units to chart ECN# 4438				

39A Presidio
EQUALIZER JACKS (FULLY AUTOMATIC)
STANDARD ON THIS UNIT

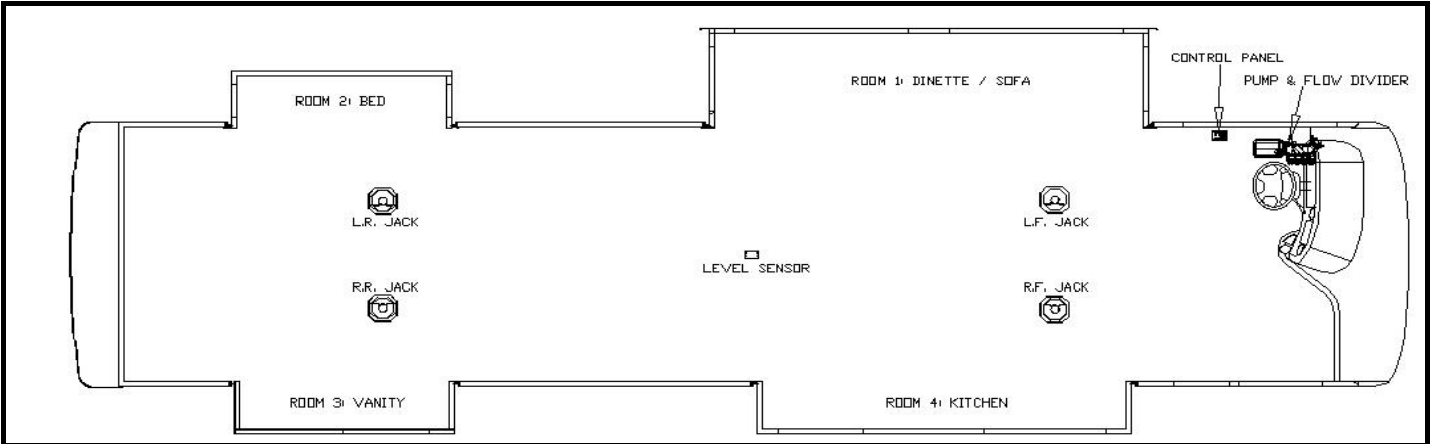

Notes:

- 1) Jacks mount to chassis brackets with the lowest holes of the jacks aligned with the lowest holes of the mounting brackets.
- 2) Level sensor attaches to bottom of structure; on the square tube the runs full length from axle to axle.
- 3) Hydraulic hose terminations for room #1, #3, & #4 require 90 degree swivel elbows.
- 4) Reference FM-3991 for a better visual of Room 1 hydraulic connections.
- 5) Hoses marked w90 will have the 90 deg fitting shipped loose.

Item, Length	Description / Location	Qty	Color	Vendor PN		
Kit	(Items listed below)	1		8294		
Pump	8-Function, 4 Rooms & Jacks	1		7302		
Jack	17,000 lbs, 18" Stroke	4		7134		
Touch Pad	Located to the left of the drivers seat	1		2318		
Control Box	Attached to bottom of structure	1		2319		
Sync Cylinder	Mounted behind LP tank	1		7387		
Hose, 144	Pump to Jack, Left Front	2	Brown	2467	Measuring from inside of firewall, this is the end location of the hydraulic hoses where they attach to the slide mechanism.	
Hose, 396	Pump to Jack, Left Rear	2	Orange	2483		
Hose, 144	Pump to Jack, Right Front	2	White	2467		
Hose, 396	Pump to Jack, Right Rear	2	Yellow	2483		
Hose, 144	Pump to synchronizing cylinder	2	Green	2467		
Hose w90, 168	Sync cylinder to front slide, Room 1	2	Green	2469		103 / Drivers side
Hose w90, 168	Sync cylinder to rear slide, Room 1	2	Green	2469		196 / Drivers side
	Pump to Room 1	N/A	Green			
Hose, 480	Pump to Room 2	2	Purple	2490		340 / Drivers Side
Hose w90, 432	Pump to Room 3	2	Gray	2486		365 / Passenger Side
Hose w90, 228	Pump to Room 4	2	Red	2474	146 / Passenger Side	
	Pump to Generator Slide	N/A			N/A	
Travel Clamp	(two per slide, except the bed slide)	6		HWH	N/A	

Options

Item, Length	Description / Location	Qty	Color	Vendor PN	

Revisions

	Beginning with release of 1/23/06 and documented on ECN #3845
1	ECN#4099 Equalizer standardize sizes & renumbers parts, 90 deg fitting ship loose

**39B Presidio
EQUALIZER JACKS (FULLY AUTOMATIC)
STANDARD ON THIS UNIT**

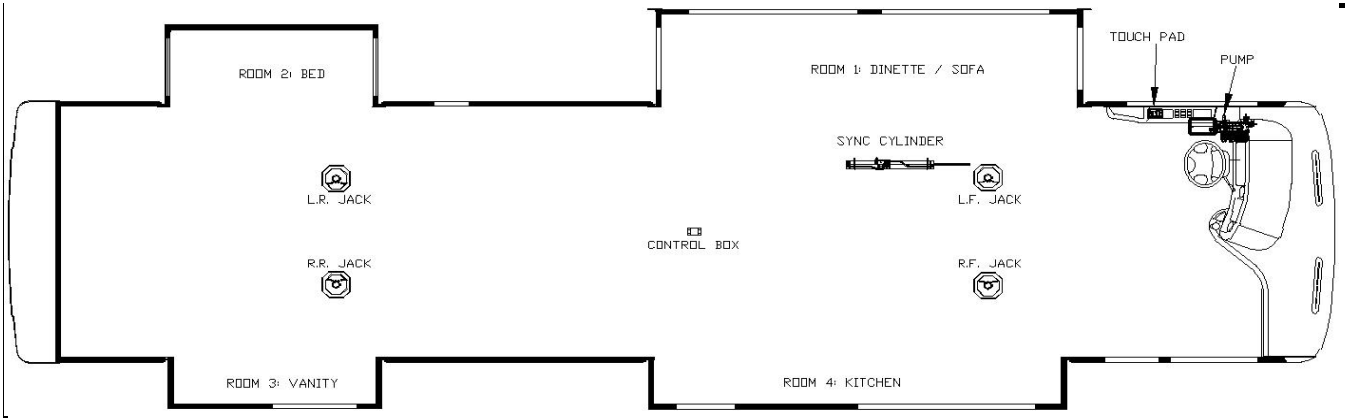

- Notes:**
- 1) Jacks mount to chassis brackets with the lowest holes of the jacks aligned with the lowest holes of the mounting brackets.
 - 2) Level sensor attaches to bottom of structure; on the square tube the runs full length from axle to axle.
 - 3) Hydraulic hose terminations for room #1, #3, & #4 require 90 degree swivel elbows.
 - 4) Reference FM-3991 for a better visual of Room 1 hydraulic connections.
 - 5) Hoses marked w90 will have the 90 deg fitting shipped loose.

Item, Length	Description / Location	Qty	Color	Vendor PN		
Kit	(Items listed below)	1		8294	Measuring from inside of firewall, this is the end location of the hydraulic hoses where they attach to the slide mechanism.	
Pump	8-Function, 4 Rooms & Jacks	1		7302		
Jack	17,000 lbs, 18" Stroke	4		7134		
Touch Pad	Located to the left of the drivers seat	1		2318		
Control Box	Attached to bottom of structure	1		2319		
Sync Cylinder	Mounted behind LP tank	1		7387		
Hose, 144	Pump to Jack, Left Front	2	Brown	2467		
Hose, 396	Pump to Jack, Left Rear	2	Orange	2483		
Hose, 144	Pump to Jack, Right Front	2	White	2467		
Hose, 396	Pump to Jack, Right Rear	2	Yellow	2483		
Hose, 144	Pump to synchronizing cylinder	2	Green	2467		
Hose w90, 168	Sync cylinder to front slide, Room 1	2	Green	2469		Mounts to bracket on structure 103 / Drivers side
Hose w90, 168	Sync cylinder to rear slide, Room 1	2	Green	2469		196 / Drivers side
	Pump to Room 1	N/A	Green			
Slide Unit	Room 1 - 36" flush floor slide	2		7164D		
Hose, 480	Pump to Room 2	2	Purple	2490	340 / Drivers Side	
Slide Unit	Room 2 - 30" Bed slide (Lippert)	1		143960		
Hose w90, 432	Pump to Room 3	2	Gray	2486	365 / Passenger Side	
Slide Unit	Room 3 - 18" above floor slide	1		7135		
Hose w90, 228	Pump to Room 4	2	Red	2474	155 / Passenger Side	
Slide Unit	Room 4 - 18" above floor slide	1		7135		
	Pump to Generator Slide	N/A			N/A	
Travel Clamp	(two per slide, except the bed slide)	6		HWH	N/A	

Options					

Revisions	
	Beginning with release of 1/23/06 and documented on ECN #3845
1	ECN#4099 Equalizer standardize sizes & rennumbers parts, 90 deg fitting ship loose
2	UPDATE JPG
3	Updated per ECN #4237

**39C Presidio
EQUALIZER JACKS (FULLY AUTOMATIC)
STANDARD ON THIS UNIT**

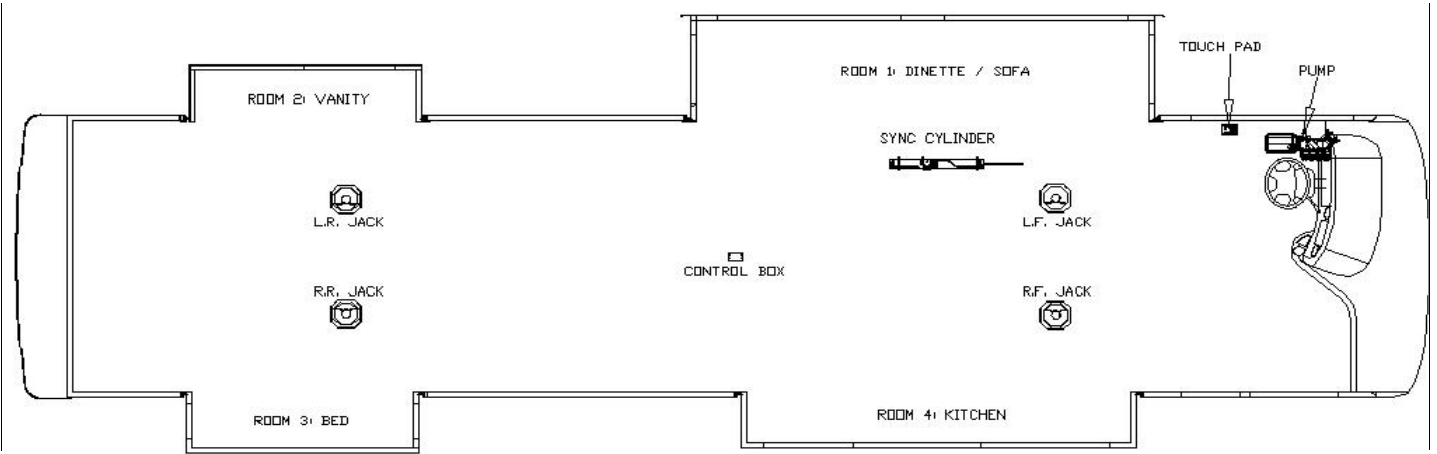

Notes:

- 1) Jacks mount to chassis brackets with the lowest holes of the jacks aligned with the lowest holes of the mounting brackets.
- 2) Level sensor attaches to bottom of structure; on the square tube the runs full length from axle to axle.
- 3) Hydraulic hose terminations for room #1, #2, & #4 require 90 degree swivel elbows.
- 4) Reference FM-3991 for a better visual of Room 1 hydraulic connections.
- 5) Hoses marked w90 will have the 90 deg fitting shipped loose.

Item, Length	Description / Location	Qty	Color	Vendor PN		
Kit	(Items listed below)	1		8293	Measuring from inside of firewall, this is the end location of the hydraulic hoses where they attach to the slide mechanism.	
Pump	8-Function, 4 Rooms & Jacks	1		7302		
Jack	17,000 lbs, 18" Stroke	4		7134		
Touch Pad	Located to the left of the drivers seat	1		2318		
Control Box	Attached to bottom of structure	1		2319		
Sync Cylinder	Mounted behind LP tank	1		7387		
Hose, 144	Pump to Jack, Left Front	2	Brown	2467		
Hose, 396	Pump to Jack, Left Rear	2	Orange	2483		
Hose, 144	Pump to Jack, Right Front	2	White	2467		
Hose, 396	Pump to Jack, Right Rear	2	Yellow	2483		
Hose, 144	Pump to synchronizing cylinder	2	Green	2467		Mounts to bracket on structure
Hose w90, 168	Sync cylinder to front slide, Room 1	2	Green	2469		103 / Drivers side
Hose w90, 168	Sync cylinder to rear slide, Room 1	2	Green	2469		196 / Drivers side
	Pump to Room 1	N/A	Green			
Hose w90, 432	Pump to Room 2	2	Purple	2486	350 / Drivers Side	
Hose, 480	Pump to Room 3	2	Gray	2490	345 / Passenger Side	
Hose w90, 228	Pump to Room 4	2	Red	2474	146 / Passenger Side	
	Pump to Generator Slide	N/A			N/A	
Travel Clamp	(two per slide, except the bed slide)	6		HWH	N/A	

Options

Revisions

	Beginning with release of 1/23/06 and documented on ECN #3845
1	ECN#4099 Equalizer standardize sizes & renumbers parts, 90 deg fitting ship loose
2	UPDATE JPG
3	Updated per ECN #4237

**39D Presidio
EQUALIZER JACKS (FULLY AUTOMATIC)
STANDARD ON THIS UNIT**

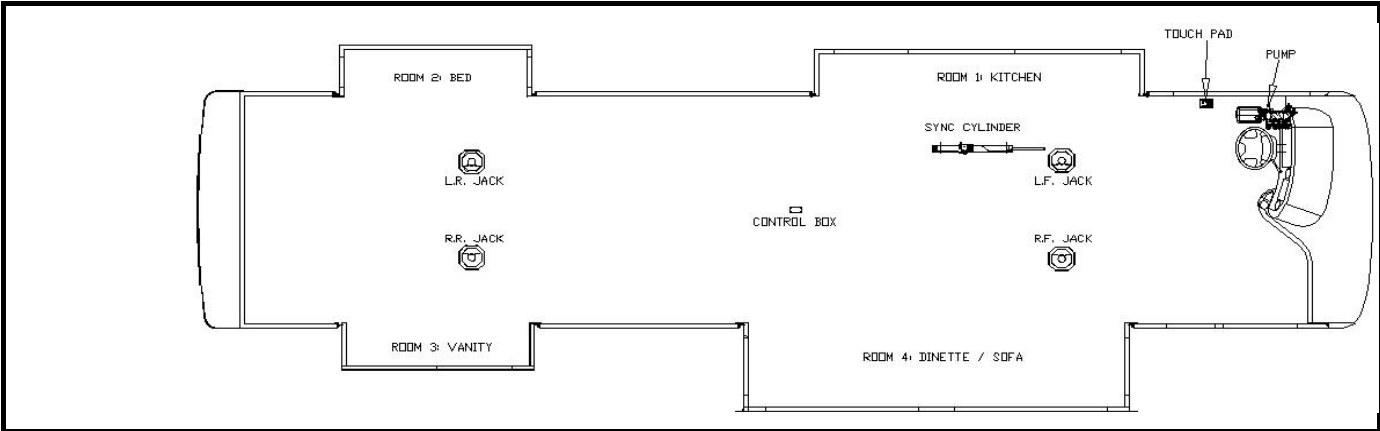

Notes:

- 1) Jacks mount to chassis brackets with the lowest holes of the jacks aligned with the lowest holes of the mounting brackets.
- 2) Level sensor attaches to bottom of structure; on the square tube the runs full length from axle to axle.
- 3) Hydraulic hose terminations for room #1, #3, & #4 require 90 degree swivel elbows.
- 4) Reference FM-3991 for a better visual of Room 4 hydraulic connections.
- 5) Hoses marked w90 will have the 90 deg fitting shipped loose.

Item, Length	Description / Location	Qty	Color	Vendor PN	
Kit	(Items listed below)	1		8292	
Pump	8-Function, 4 Rooms & Jacks	1		7302	Measuring from inside of firewall, this is the end location of the hydraulic hoses where they attach to the slide mechanism.
Jack	17,000 lbs, 18" Stroke	4		7134	
Touch Pad	Located to the left of the drivers seat	1		2318	
Control Box	Attached to bottom of structure	1		2319	
Sync Cylinder	Mounted behind LP tank	1		7387	
Hose, 144	Pump to Jack, Left Front	2	Brown	2467	
Hose, 396	Pump to Jack, Left Rear	2	Orange	2483	
Hose, 144	Pump to Jack, Right Front	2	White	2467	
Hose, 396	Pump to Jack, Right Rear	2	Yellow	2483	
Hose, 144	Pump to synchronizing cylinder	2	Red	2467	
Hose w90, 168	Pump to Room 1	2	Green	2469	Mounts to bracket on structure 149 / Drivers side
Slide Unit	Room 1 - 18" above floor slide	1		7135	
Hose, 480	Pump to Room 2	2	Purple	2490	325 / Drivers Side
Slide Unit	Room 2 - 30" Bed slide (Lippert)	1		143960	
Hose w90, 432	Pump to Room 3	2	Gray	2486	355 / Passenger Side
Slide Unit	Room 3 - 18" above floor slide	1		7135	
Hose w90, 168	Sync cylinder to front slide, Room 4	2	Red	2469	103 / Passenger side
Hose w90, 168	Sync cylinder to rear slide, Room 4	2	Red	2469	196 / Passenger side
Slide Unit	Room 4 - 36" flush floor slide	2		7164D	
	Pump to Generator Slide	N/A			N/A
Travel Clamp	(two per slide, except the bed slide)	6		HWH	N/A

Options

Revisions

	Beginning with release of 1/23/06 and documented on ECN #3845
1	Equalizer lengthened hose....part #2415 (was too short per S. Jung email on 4/27)
2	ECN#4099 Equalizer standardize sizes & rennumbers parts, 90 deg fitting ship loose
3	UPDATE JPG

**39E Presidio
EQUALIZER JACKS (FULLY AUTOMATIC)
STANDARD ON THIS UNIT**

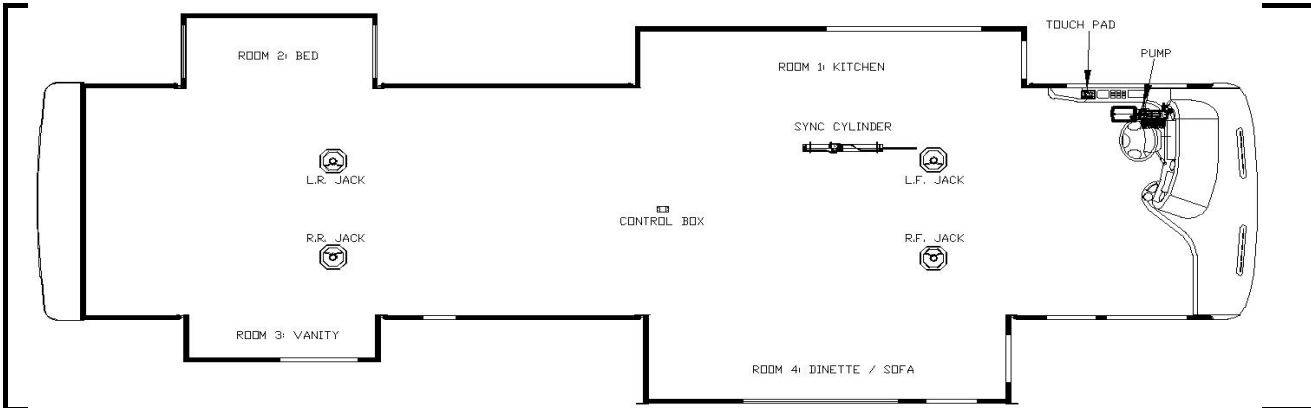

Notes:

- 1) Jacks mount to chassis brackets with the lowest holes of the jacks aligned with the lowest holes of the mounting brackets.
- 2) Level sensor attaches to bottom of structure; on the square tube the runs full length from axle to axle.
- 3) Hydraulic hose terminations for room #1, #3, & #4 require 90 degree swivel elbows.
- 4) Reference FM-3991 for a better visual of Room 4 hydraulic connections.
- 5) Hoses marked w90 will have the 90 deg fitting shipped loose.

Item, Length	Description / Location	Qty	Color	Vendor PN	
Kit	(Items listed below)	1		8315	
Pump	8-Function, 4 Rooms & Jacks	1		7302	Measuring from inside of firewall, this is the end location of the hydraulic hoses where they attach to the slide mechanism.
Jack	17,000 lbs, 18" Stroke	4		7134	
Touch Pad	Located to the left of the drivers seat	1		2318	
Control Box	Attached to bottom of structure	1		2319	
Sync Cylinder	Mounted behind LP tank	2		7397	
Hose, 144	Pump to Jack, Left Front	2	Brown	2467	
Hose, 396	Pump to Jack, Left Rear	2	Orange	2483	
Hose, 144	Pump to Jack, Right Front	2	White	2467	
Hose, 396	Pump to Jack, Right Rear	2	Yellow	2483	
Hose, 144	Pump to synchronizing cylinder	2	Green	2467	
Hose, 144	Pump to synchronizing cylinder	2	Red	2467	Mounts to bracket on structure
Hose, 480	Pump to Room 2	2	Purple	2490	325 / Drivers Side
Slide Unit	Room 2 - 30" Bed slide (Lippert)	1		143960	
Hose w90, 432	Pump to Room 3	2	Gray	2486	355 / Passenger Side
Slide Unit	Room 3 - 18" above floor slide	1		7135	
Hose w90, 168	Sync cylinder to front slide, Room 1	2	Green	2469	95 / Drivers Side
Hose w90, 168	Sync cylinder to rear slide, Room 1	2	Green	2469	180 / Drivers Side
Slide Unit	Room 1 - 24" flush floor slide	2		7369	
Hose w90, 168	Sync cylinder to front slide, Room 4	2	Red	2469	103 / Passenger side
Hose w90, 168	Sync cylinder to rear slide, Room 4	2	Red	2469	196 / Passenger side
Slide Unit	Room 4 - 24" flush floor slide	2		7369	
	Pump to Generator Slide	N/A			N/A
Travel Clamp	(two per slide, except the bed slide)	6		HWH	N/A

Options

Revisions

1	ECN#4099 Equalizer standardize sizes & renumpers parts, 90 deg fitting ship loose
2	UPDATE JPG
3	Updated per ECN #4237
3	Added equalizer slide units to chart ECN# 4438

**39F Presidio
EQUALIZER JACKS (FULLY AUTOMATIC)
STANDARD ON THIS UNIT**

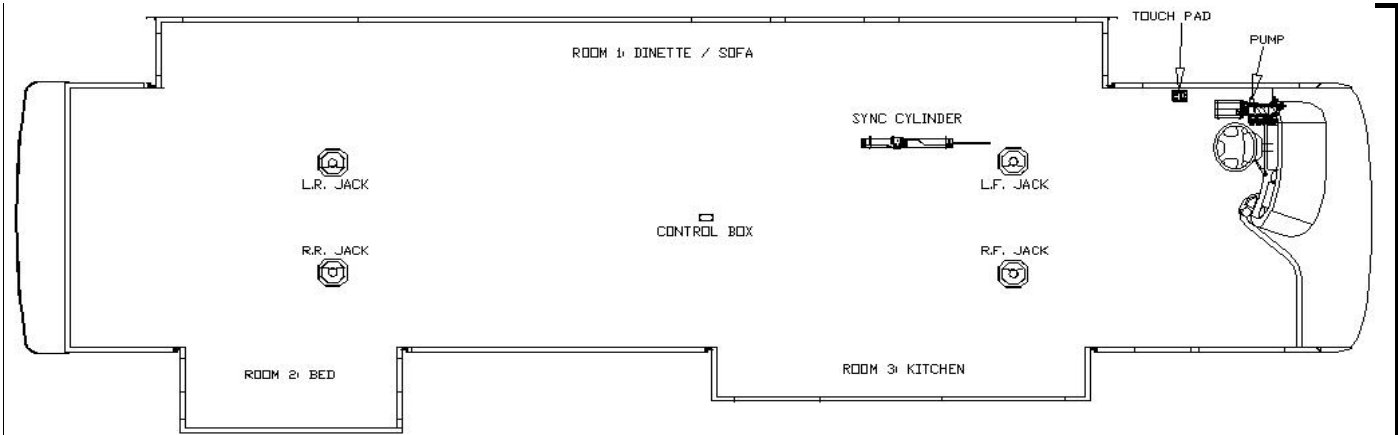

- Notes:**
- 1) Jacks mount to chassis brackets with the lowest holes of the jacks aligned with the lowest holes of the mounting brackets.
 - 2) Level sensor attaches to bottom of structure; on the square tube the runs full length from axle to axle.
 - 3) Hydraulic hose terminations for room #1 & #2 require 90 degree swivel elbows.
 - 4) Room #1 will have a non-powered slide mechanism in center of room
 - 5) Hoses marked w90 will have the 90 deg fitting shipped loose.

Item, Length	Description / Location	Qty	Color	Vendor PN	
Kit	(Items listed below)	1		8340	
Pump	7-Function, 4 Rooms & Jacks	1		7319	
Jack	17,000 lbs, 18" Stroke	4		7134	
Touch Pad	Located to the left of the drivers seat	1		2318	
Control Box	Attached to bottom of structure	1		2319	
Sync Cylinder	Mounted behind LP tank	1		7397	
Hose, 144	Pump to Jack, Left Front	2	Brown	2467	
Hose, 396	Pump to Jack, Left Rear	2	Orange	2483	
Hose, 144	Pump to Jack, Right Front	2	White	2467	
Hose, 396	Pump to Jack, Right Rear	2	Yellow	2483	
Hose, 144	Pump to synchronizing cylinder	2	Green	2467	Mounts to bracket on structure
Hose w90, 432	Sync cylinder to front slide, Room 1	2	Green	2486	103 / Drivers side
Hose w90, 432	Sync cylinder to rear slide, Room 1	2	Green	2486	350 / Drivers side
Slide Unit	Room 1 - 24" flush floor slide (angled)	2		7388	
Slide Unit	Room 1 - 24" flush floor slide (angled)	1		7384	Slave
Hose, 480	Pump to Room 2	2	Purple	2490	345 / Drivers Side
Slide Unit	Room 2 - 30" Bed slide (Lippert)	1		143960	
Hose w90, 228	Pump to Room 3	2	Gray	2474	146 / Passenger Side
Slide Unit	Room 3 - 18" above floor slide	1		7135	
	Pump to Generator Slide	N/A			N/A
Travel Clamp	(two per slide, except the bed slide)	4		HWH	N/A
Options					

Revisions					
1	UPDATE JPG				
2	Updated per ECN #4237				
3	Added equalizer slide units to chart ECN# 4438				

**39G Presidio
EQUALIZER JACKS (FULLY AUTOMATIC)
STANDARD ON THIS UNIT**

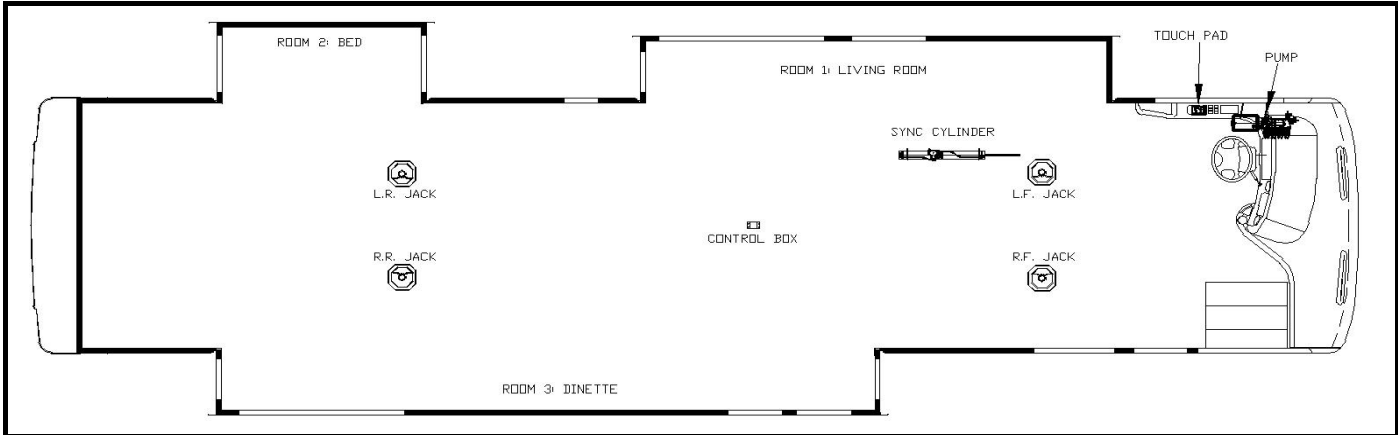

Notes:

- 1) Jacks mount to chassis brackets with the lowest holes of the jacks aligned with the lowest holes of the mounting brackets.
- 2) Level sensor attaches to bottom of structure; on the square tube the runs full length from axle to axle.
- 3) Hydraulic hose terminations for room #1 & #2 require 90 degree swivel elbows.
- 4) Room #1 will have a non-powered slide mechanism in center of room
- 5) Hoses marked w90 will have the 90 deg fitting shipped loose.

Item, Length	Description / Location	Qty	Color	Vendor PN	
Kit	(Items listed below)	1		8354	
Pump	7-Function, 3 Rooms & Jacks	1		7319	
Jack	17,000 lbs, 18" Stroke	4		7134	
Touch Pad	Located to the left of the drivers seat	1		2318	
Control Box	Attached to bottom of structure	1		2319	
Sync Cylinder	Mounted behind LP tank	2		7397	
Hose, 144	Pump to Jack, Left Front	2	Brown	2467	
Hose, 408	Pump to Jack, Left Rear	2	Orange	2484	
Hose, 144	Pump to Jack, Right Front	2	White	2467	
Hose, 408	Pump to Jack, Right Rear	2	Yellow	2484	
Hose, 144	Pump to synchronizing cylinder	2	Green	2467	Mounts to bracket on structure
Hose w90, 168	Sync cylinder to front slide, Room 1	2	Green	2469	103 / Drivers side
Hose w90, 168	Sync cylinder to rear slide, Room 1	2	Green	2469	205 / Drivers side
Slide Unit	Room 1 - 24" flush floor slide (angled)	2		7388	
Hose w90, 360	Sync cylinder to front slide, Room 3	2	Gray	2527	205 / Passenger side
Hose w90, 360	Sync cylinder to rear slide, Room 3	2	Gray	2527	350 / Passenger side
Slide Unit	Room 3 - 24" flush floor slide (angled)	2		7388	
Hose, 480	Pump to Room 2	2	Purple	2490	345 / Drivers Side
Slide Unit	Room 2 - 30" Bed slide (Lippert)	1		143960	
	Pump to Generator Slide	N/A			N/A
Travel Clamp	(two per slide, except the bed slide)	4		HWH	N/A
Hose, 144	Pump to synchronizing cylinder	2	Gray	2467	Mounts to bracket on structure

Measuring from inside of firewall, this is the end location of the hydraulic hoses where they attach to the slide mechanism.

Options

Revisions

1	Corrected picture
2	Corrected hose notes for room #3 & #1.....3-5-07
3	Added equalizer slide units to chart ECN# 4438

**36B Presidio
EQUALIZER JACKS (FULLY AUTOMATIC)
STANDARD ON THIS UNIT**

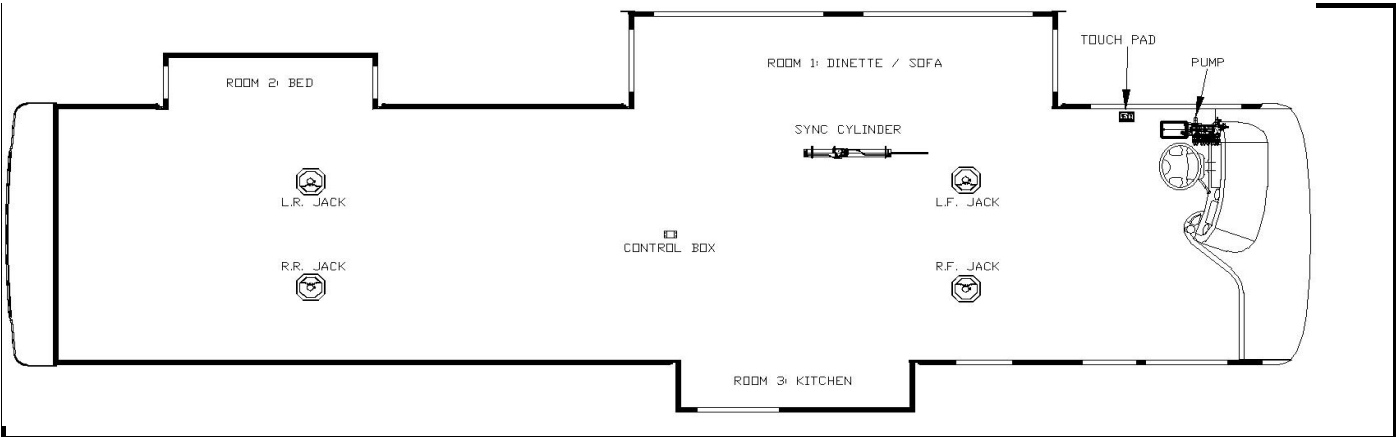

Notes:

- 1) Jacks mount to chassis brackets with the lowest holes of the jacks aligned with the lowest holes of the mounting brackets.
- 2) Level sensor attaches to bottom of structure; on lower hat section flanges or square tube.
- 3) Hydraulic hose terminations for room #1 & #3 require 90 degree swivel elbows.
- 4) Reference FM-3991 for a better visual of Room 1 hydraulic connections.
- 5) Hoses marked w90 will have the 90 deg fitting shipped loose.

Item, Length	Description / Location	Qty	Color	Vendor PN	
Kit	(Items listed below)	1		8310	Measuring from inside of firewall, this is the end location of the hydraulic hoses where they attach to the slide mechanism.
Pump	7-Function, 3 Rooms & Jacks	1		7319	
Jack	17,000 lbs, 18" Stroke	4		7134	
Touch Pad	Located to the left of the drivers seat	1		2318	
Control Box	Attached to bottom of structure	1		2319	
Sync Cylinder	Mounted behind LP tank	1		7387	
Hose, 132	Pump to Jack, Left Front	2	Brown	2466	
Hose, 372	Pump to Jack, Left Rear	2	Orange	2481	
Hose, 144	Pump to Jack, Right Front	2	White	2467	
Hose, 372	Pump to Jack, Right Rear	2	Yellow	2481	
Hose, 144	Pump to synchronizing manifold	2	Green	2467	Mounts to bracket on structure
Hose w90, 168	Sync cylinder to front slide, Room 1	2	Green	2469	103 / Drivers side
Hose w90, 168	Sync cylinder to rear slide, Room 1	2	Green	2469	196 / Drivers side
	Pump to Room 1	N/A	Green		
Slide Unit	Room 1 - 36" flush floor slide	2		7164D	
Hose, 420	Pump to Room 2	2	Purple	2485	325 / Drivers Side
Slide Unit	Room 2 - 30" Bed slide (Lippert)	1		143960	
Hose w90, 204	Pump to Room 3	2	Red	2472	146 / Passenger Side
Slide Unit	Room 3 - 18" above floor slide	1		7135	
	Pump to Generator Slide	N/A			N/A
Travel Clamp	(two per slide, except the bed slide)	4		HWH	N/A
Options					
Revisions					
1	Added equalizer slide units to chart ECN# 4438				

**38C Presidio
EQUALIZER JACKS (FULLY AUTOMATIC)
STANDARD ON THIS UNIT**

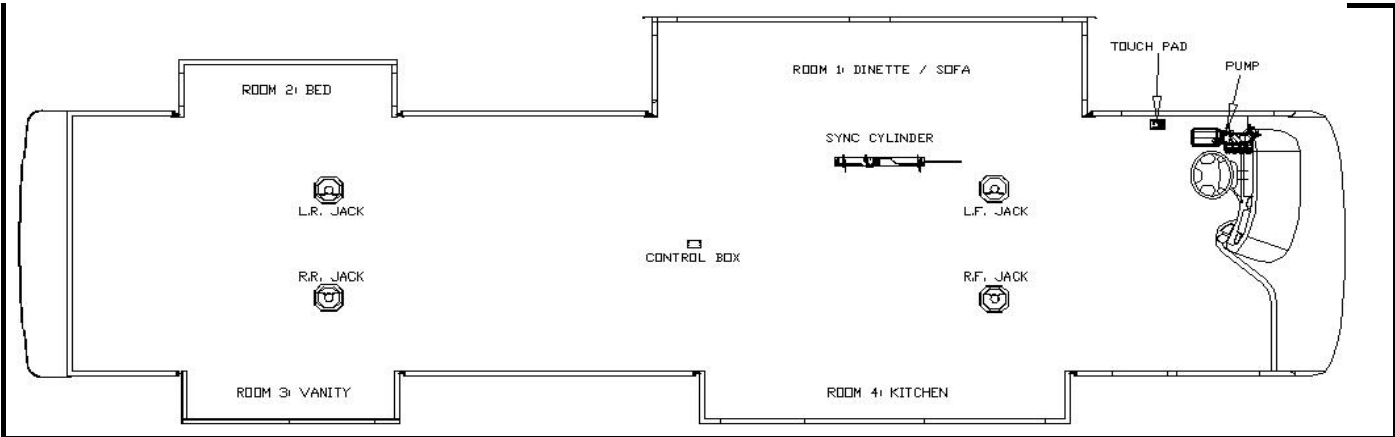

Notes:

- 1) Jacks mount to chassis brackets with the lowest holes of the jacks aligned with the lowest holes of the mounting brackets.
- 2) Level sensor attaches to bottom of structure; on lower hat section flanges or square tube.
- 3) Hydraulic hose terminations for room #1, #3, & #4 require 90 degree swivel elbows.
- 4) Reference FM-3991 for a better visual of Room 1 hydraulic connections.
- 5) Hoses marked w90 will have the 90 deg fitting shipped loose.

Item, Length	Description / Location	Qty	Color	Vendor PN	
Kit	(Items listed below)	1		8278	
Pump	8-Function, 4 Rooms & Jacks	1		7302	
Jack	17,000 lbs, 18" Stroke	4		7134	
Touch Pad	Located to the left of the drivers seat	1		2318	
Control Box	Attached to bottom of structure	1		2319	
Sync Cylinder	Mounted behind LP tank	1		7387	
Hose, 132	Pump to Jack, Left Front	2	Brown	2466	
Hose, 372	Pump to Jack, Left Rear	2	Orange	2481	
Hose, 144	Pump to Jack, Right Front	2	White	2467	
Hose, 372	Pump to Jack, Right Rear	2	Yellow	2481	
Hose, 144	Pump to synchronizing manifold	2	Green	2467	Mounts to bracket on structure
Hose w90, 168	Sync cylinder to front slide, Room 1	2	Green	2469	103 / Drivers side
Hose w90, 168	Sync cylinder to rear slide, Room 1	2	Green	2469	196 / Drivers side
	Pump to Room 1	N/A	Green		
Slide Unit	Room 1 - 36" flush floor slide	2		7164D	
Hose, 420	Pump to Room 2	2	Purple	2485	325 / Drivers Side
Slide Unit	Room 2 - 30" Bed slide (Lippert)	1		143960	
Hose w90, 456	Pump to Room 3	2	Gray	2488	355 / Passenger Side
Slide Unit	Room 3 - 18" above floor slide	1		7135	
Hose w90, 204	Pump to Room 4	2	Red	2472	146 / Passenger Side
Slide Unit	Room 4 - 18" above floor slide	1		7135	
	Pump to Generator Slide	N/A			N/A
Travel Clamp	(two per slide, except the bed slide)	6		HWH	N/A

Options

Item, Length	Description / Location	Qty	Color	Vendor PN	

Revisions

1	Added equalizer slide units to chart ECN# 4438

**38D Presidio
EQUALIZER JACKS (FULLY AUTOMATIC)
STANDARD ON THIS UNIT**

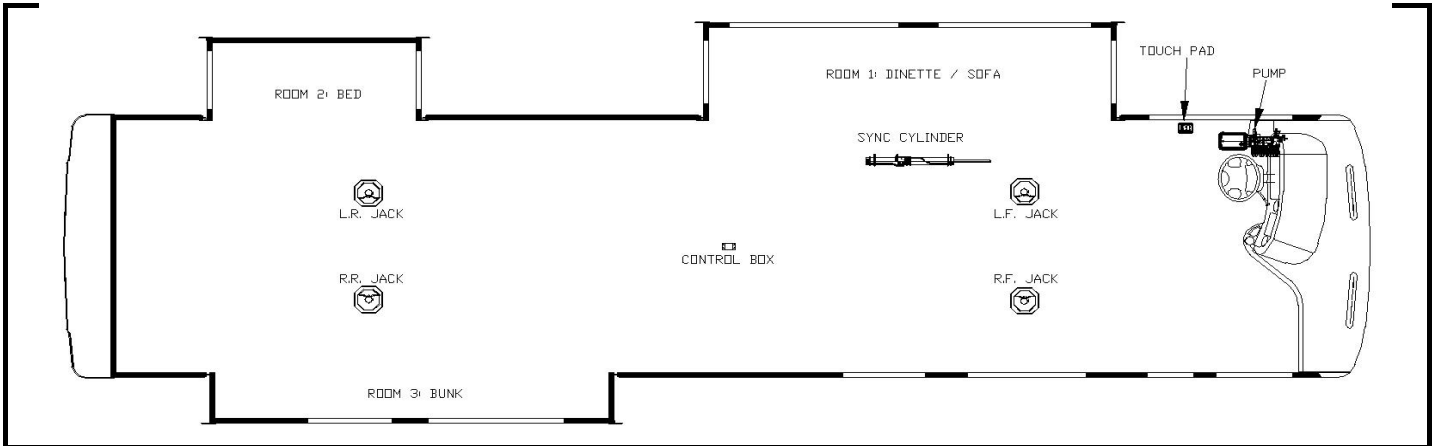

Notes:

- 1) Jacks mount to chassis brackets with the lowest holes of the jacks aligned with the lowest holes of the mounting brackets.
- 2) Level sensor attaches to bottom of structure; on lower hat section flanges or square tube.
- 3) Hydraulic hose terminations for room #1 & #3 require 90 degree swivel elbows.
- 4) Reference FM-3991 for a better visual of Room 1 hydraulic connections.
- 5) Hoses marked w90 will have the 90 deg fitting shipped loose.

Item, Length	Description / Location	Qty	Color	Vendor PN	
Kit	(Items listed below)	1		8347	
Pump	7-Function, 3 Rooms & Jacks	1		7319	
Jack	17,000 lbs, 18" Stroke	4		7134	
Touch Pad	Located to the left of the drivers seat	1		2318	
Control Box	Attached to bottom of structure	1		2319	
Sync Cylinder	Mounted behind LP tank	1		7387	
Hose, 132	Pump to Jack, Left Front	2	Brown	2466	
Hose, 372	Pump to Jack, Left Rear	2	Orange	2481	
Hose, 144	Pump to Jack, Right Front	2	White	2467	
Hose, 372	Pump to Jack, Right Rear	2	Yellow	2481	
Hose, 144	Pump to synchronizing manifold	2	Green	2467	Mounts to bracket on structure
Hose w90, 168	Sync cylinder to front slide, Room 1	2	Green	2469	103 / Drivers side
Hose w90, 168	Sync cylinder to rear slide, Room 1	2	Green	2469	196 / Drivers side
	Pump to Room 1	N/A	Green		
Slide Unit	Room 1 - 36" flush floor slide	2		7164D	
Hose, 432	Pump to Room 2	2	Purple	2486	325 / Drivers Side
Slide Unit	Room 2 - 30" Bed slide (Lippert)	1		143960	
Hose w90, 456	Pump to Room 3	2	Gray	2488	355 / Passenger Side
Slide Unit	Room 3 - 18" above floor slide	1		7135	
	Pump to Generator Slide	N/A			
Travel Clamp	(two per slide, dinette / sofa slide only)	2		HWH	N/A

Measuring from inside of firewall, this is the end location of the hydraulic hoses where they attach to the slide mechanism.

Options

Revisions

1	Added equalizer slide units to chart ECN# 4438

**38E Presidio
EQUALIZER JACKS (FULLY AUTOMATIC)
STANDARD ON THIS UNIT**

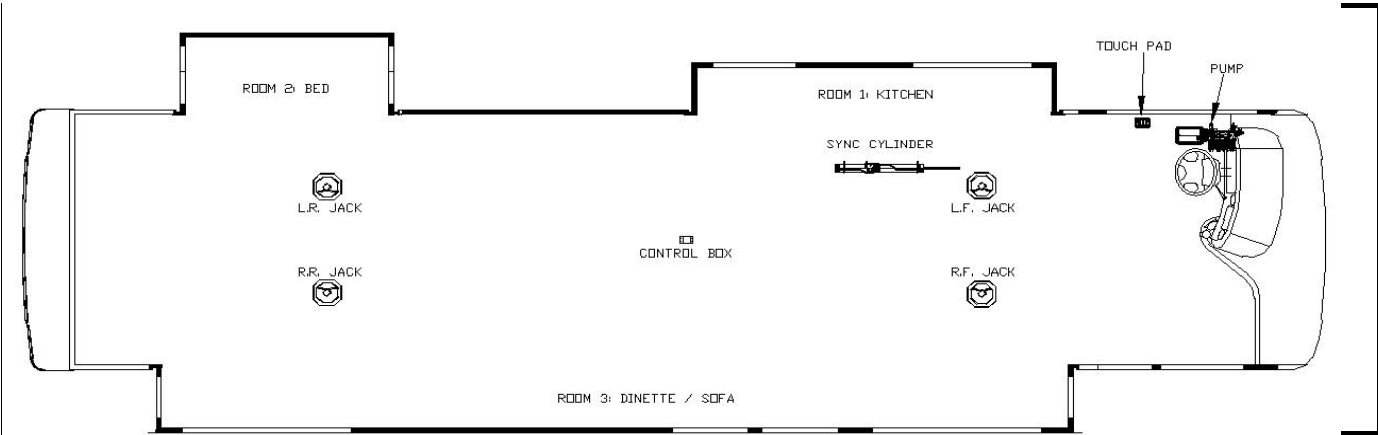

- 1) Jacks mount to chassis brackets with the lowest holes of the jacks aligned with the lowest holes of the mounting brackets.
- 2) Level sensor attaches to bottom of structure; on the square tube the runs full length from axle to axle.
- 3) Hydraulic hose terminations for room #2 & #3 require 90 degree swivel elbows.
- 4) Room #3 will have a non-powered slide mechanism in center of room
- 5) Hoses marked w90 will have the 90 deg fitting shipped loose.

Item, Length	Description / Location	Qty	Color	Vendor PN		
Kit	(Items listed below)	1		8350	Measuring from inside of firewall, this is the end location of the hydraulic hoses where they attach to the slide mechanism.	
Pump	8-Function, 4 Rooms & Jacks	1		7302		
Jack	17,000 lbs, 18" Stroke	4		7134		
Touch Pad	Located to the left of the drivers seat	1		2318		
Control Box	Attached to bottom of structure	1		2319		
Sync Cylinder	Mounted behind LP tank	1		7397		
Hose, 144	Pump to Jack, Left Front	2	Brown	2467		
Hose, 396	Pump to Jack, Left Rear	2	Orange	2483		
Hose, 144	Pump to Jack, Right Front	2	White	2467		
Hose, 396	Pump to Jack, Right Rear	2	Yellow	2483		
Hose, 144	Pump to synchronizing cylinder	2	Gray	2467		Mounts to bracket on structure
Hose w90, 168	Sync cylinder to front slide, Room 3	2	Gray	2469		103 / Drivers side
Hose w90, 432	Sync cylinder to rear slide, Room 3	2	Gray	2486		350 / Drivers side
Slide Unit	Room 3 - 24" flush floor slide (angled)	2		7388		
Slide Unit	Room 3 - 24" flush floor slide (angled)	1		7384	Slave	
	Pump to Room 1	N/A	Green			
Hose w90, 180	Pump to Room 1	2	Green	2470	146 / Passenger Side	
Slide Unit	Room 1 - 18" above floor slide	1		7135		
Hose, 480	Pump to Room 2	2	Purple	2490	345 / Drivers Side	
Slide Unit	Room 2 - 30" Bed slide (Lippert)	1		143960		
	Pump to Generator Slide	N/A			N/A	
Travel Clamp	(two per slide, except the bed slide)	4		HWH	N/A	
Options						

Revisions					
1	Added equalizer slide units to chart ECN# 4438				

39A Presidio
EQUALIZER JACKS (FULLY AUTOMATIC)
STANDARD ON THIS UNIT

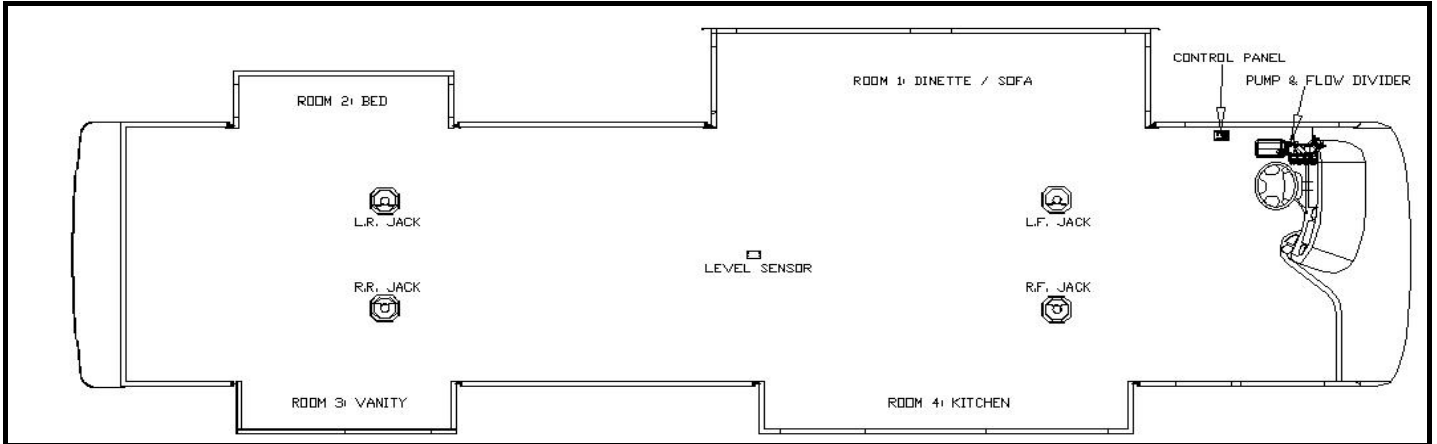

- Notes:**
- 1) Jacks mount to chassis brackets with the lowest holes of the jacks aligned with the lowest holes of the mounting brackets.
 - 2) Level sensor attaches to bottom of structure; on the square tube the runs full length from axle to axle.
 - 3) Hydraulic hose terminations for room #1, #3, & #4 require 90 degree swivel elbows.
 - 4) Reference FM-3991 for a better visual of Room 1 hydraulic connections.
 - 5) Hoses marked w90 will have the 90 deg fitting shipped loose.

Item, Length	Description / Location	Qty	Color	Vendor PN		
Kit	(Items listed below)	1		8294		
Pump	8-Function, 4 Rooms & Jacks	1		7302		
Jack	17,000 lbs, 18" Stroke	4		7134		
Touch Pad	Located to the left of the drivers seat	1		2318		
Control Box	Attached to bottom of structure	1		2319		
Sync Cylinder	Mounted behind LP tank	1		7387		
Hose, 144	Pump to Jack, Left Front	2	Brown	2467	Measuring from inside of firewall, this is the end location of the hydraulic hoses where they attach to the slide mechanism.	
Hose, 396	Pump to Jack, Left Rear	2	Orange	2483		
Hose, 144	Pump to Jack, Right Front	2	White	2467		
Hose, 396	Pump to Jack, Right Rear	2	Yellow	2483		
Hose, 144	Pump to synchronizing cylinder	2	Green	2467		
Hose w90, 168	Sync cylinder to front slide, Room 1	2	Green	2469		103 / Drivers side
Hose w90, 168	Sync cylinder to rear slide, Room 1	2	Green	2469		196 / Drivers side
	Pump to Room 1	N/A	Green			
Hose, 480	Pump to Room 2	2	Purple	2490		340 / Drivers Side
Hose w90, 432	Pump to Room 3	2	Gray	2486		365 / Passenger Side
Hose w90, 228	Pump to Room 4	2	Red	2474	146 / Passenger Side	
	Pump to Generator Slide	N/A			N/A	
Travel Clamp	(two per slide, except the bed slide)	6		HWH	N/A	

Options					

Revisions	
	Beginning with release of 1/23/06 and documented on ECN #3845
1	ECN#4099 Equalizer standardize sizes & renumbers parts, 90 deg fitting ship loose

**39B Presidio
EQUALIZER JACKS (FULLY AUTOMATIC)
STANDARD ON THIS UNIT**

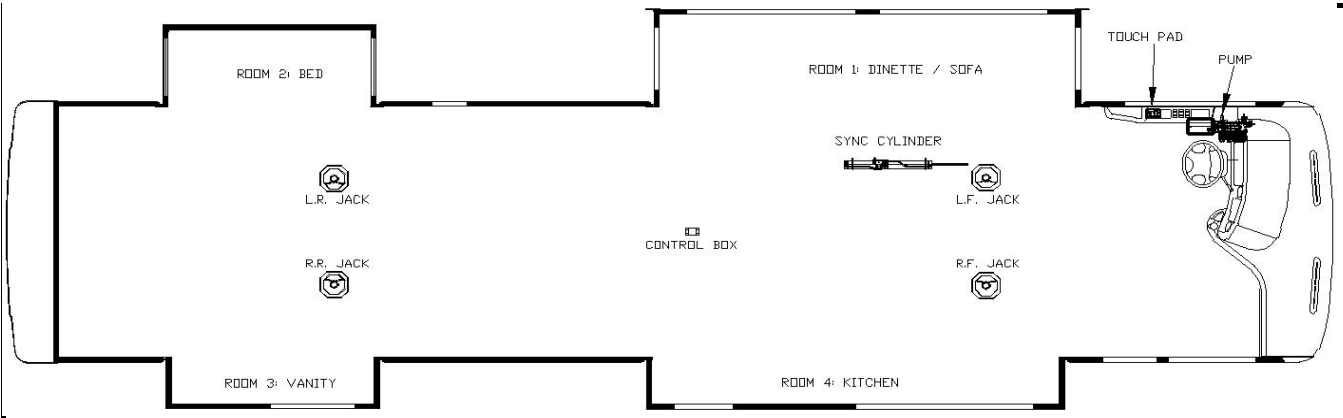

Notes:

- 1) Jacks mount to chassis brackets with the lowest holes of the jacks aligned with the lowest holes of the mounting brackets.
- 2) Level sensor attaches to bottom of structure; on the square tube the runs full length from axle to axle.
- 3) Hydraulic hose terminations for room #1, #3, & #4 require 90 degree swivel elbows.
- 4) Reference FM-3991 for a better visual of Room 1 hydraulic connections.
- 5) Hoses marked w90 will have the 90 deg fitting shipped loose.

Item, Length	Description / Location	Qty	Color	Vendor PN		
Kit	(Items listed below)	1		8294	Measuring from inside of firewall, this is the end location of the hydraulic hoses where they attach to the slide mechanism.	
Pump	8-Function, 4 Rooms & Jacks	1		7302		
Jack	17,000 lbs, 18" Stroke	4		7134		
Touch Pad	Located to the left of the drivers seat	1		2318		
Control Box	Attached to bottom of structure	1		2319		
Sync Cylinder	Mounted behind LP tank	1		7387		
Hose, 144	Pump to Jack, Left Front	2	Brown	2467		
Hose, 396	Pump to Jack, Left Rear	2	Orange	2483		
Hose, 144	Pump to Jack, Right Front	2	White	2467		
Hose, 396	Pump to Jack, Right Rear	2	Yellow	2483		
Hose, 144	Pump to synchronizing cylinder	2	Green	2467		
Hose w90, 168	Sync cylinder to front slide, Room 1	2	Green	2469		Mounts to bracket on structure 103 / Drivers side
Hose w90, 168	Sync cylinder to rear slide, Room 1	2	Green	2469		196 / Drivers side
	Pump to Room 1	N/A	Green			
Slide Unit	Room 1 - 36" flush floor slide	2		7164D		
Hose, 480	Pump to Room 2	2	Purple	2490		340 / Drivers Side
Slide Unit	Room 2 - 30" Bed slide (Lippert)	1		143960		
Hose w90, 432	Pump to Room 3	2	Gray	2486	365 / Passenger Side	
Slide Unit	Room 3 - 18" above floor slide	1		7135		
Hose w90, 228	Pump to Room 4	2	Red	2474	155 / Passenger Side	
Slide Unit	Room 4 - 18" above floor slide	1		7135		
	Pump to Generator Slide	N/A			N/A	
Travel Clamp	(two per slide, except the bed slide)	6		HWH	N/A	
Options						
Revisions						
	Beginning with release of 1/23/06 and documented on ECN #3845					
1	ECN#4099 Equalizer standardize sizes & rennumbers parts, 90 deg fitting ship loose					
2	UPDATE JPG					
3	Updated per ECN #4237					

**39C Presidio
EQUALIZER JACKS (FULLY AUTOMATIC)
STANDARD ON THIS UNIT**

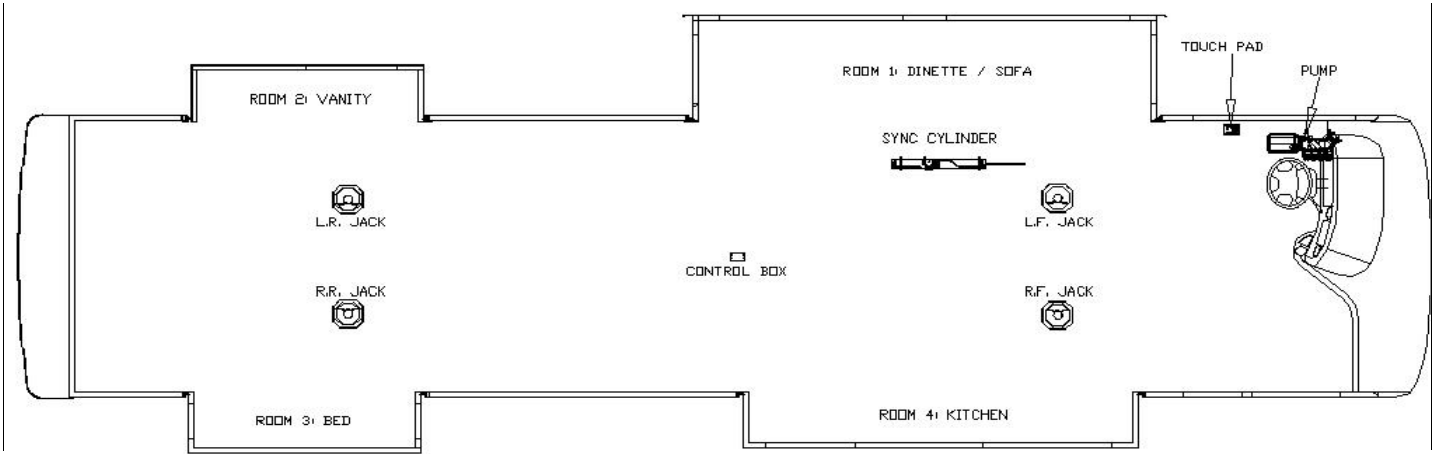

Notes:

- 1) Jacks mount to chassis brackets with the lowest holes of the jacks aligned with the lowest holes of the mounting brackets.
- 2) Level sensor attaches to bottom of structure; on the square tube the runs full length from axle to axle.
- 3) Hydraulic hose terminations for room #1, #2, & #4 require 90 degree swivel elbows.
- 4) Reference FM-3991 for a better visual of Room 1 hydraulic connections.
- 5) Hoses marked w90 will have the 90 deg fitting shipped loose.

Item, Length	Description / Location	Qty	Color	Vendor PN		
Kit	(Items listed below)	1		8293	Measuring from inside of firewall, this is the end location of the hydraulic hoses where they attach to the slide mechanism.	
Pump	8-Function, 4 Rooms & Jacks	1		7302		
Jack	17,000 lbs, 18" Stroke	4		7134		
Touch Pad	Located to the left of the drivers seat	1		2318		
Control Box	Attached to bottom of structure	1		2319		
Sync Cylinder	Mounted behind LP tank	1		7387		
Hose, 144	Pump to Jack, Left Front	2	Brown	2467		
Hose, 396	Pump to Jack, Left Rear	2	Orange	2483		
Hose, 144	Pump to Jack, Right Front	2	White	2467		
Hose, 396	Pump to Jack, Right Rear	2	Yellow	2483		
Hose, 144	Pump to synchronizing cylinder	2	Green	2467		Mounts to bracket on structure
Hose w90, 168	Sync cylinder to front slide, Room 1	2	Green	2469		103 / Drivers side
Hose w90, 168	Sync cylinder to rear slide, Room 1	2	Green	2469		196 / Drivers side
	Pump to Room 1	N/A	Green			
Hose w90, 432	Pump to Room 2	2	Purple	2486	350 / Drivers Side	
Hose, 480	Pump to Room 3	2	Gray	2490	345 / Passenger Side	
Hose w90, 228	Pump to Room 4	2	Red	2474	146 / Passenger Side	
	Pump to Generator Slide	N/A			N/A	
Travel Clamp	(two per slide, except the bed slide)	6		HWH	N/A	

Options

Item, Length	Description / Location	Qty	Color	Vendor PN	

Revisions

	Beginning with release of 1/23/06 and documented on ECN #3845
1	ECN#4099 Equalizer standardize sizes & renumbers parts, 90 deg fitting ship loose
2	UPDATE JPG
3	Updated per ECN #4237

**39D Presidio
EQUALIZER JACKS (FULLY AUTOMATIC)
STANDARD ON THIS UNIT**

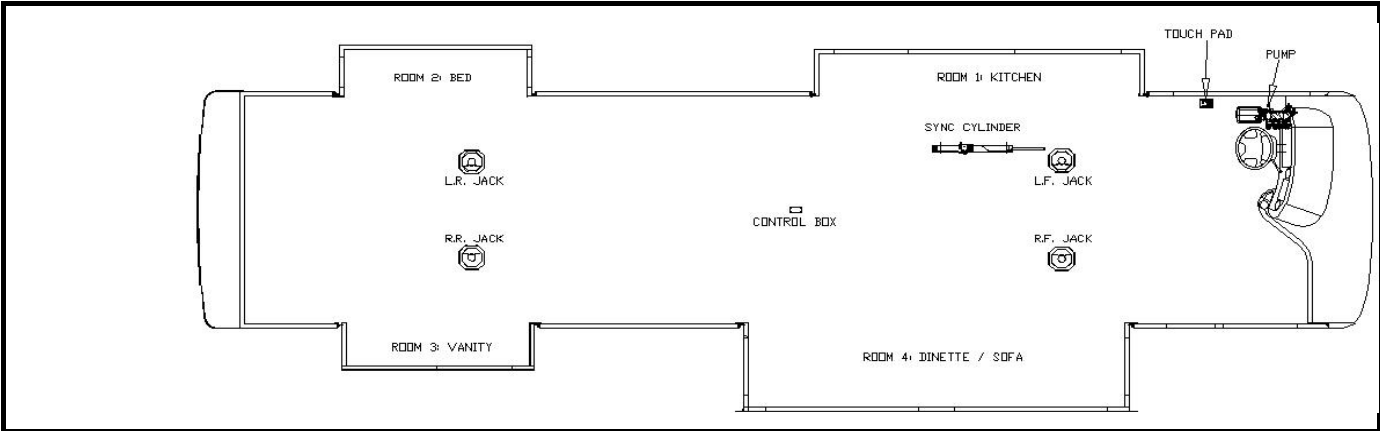

Notes:

- 1) Jacks mount to chassis brackets with the lowest holes of the jacks aligned with the lowest holes of the mounting brackets.
- 2) Level sensor attaches to bottom of structure; on the square tube the runs full length from axle to axle.
- 3) Hydraulic hose terminations for room #1, #3, & #4 require 90 degree swivel elbows.
- 4) Reference FM-3991 for a better visual of Room 4 hydraulic connections.
- 5) Hoses marked w90 will have the 90 deg fitting shipped loose.

Item, Length	Description / Location	Qty	Color	Vendor PN	
Kit	(Items listed below)	1		8292	
Pump	8-Function, 4 Rooms & Jacks	1		7302	Measuring from inside of firewall, this is the end location of the hydraulic hoses where they attach to the slide mechanism.
Jack	17,000 lbs, 18" Stroke	4		7134	
Touch Pad	Located to the left of the drivers seat	1		2318	
Control Box	Attached to bottom of structure	1		2319	
Sync Cylinder	Mounted behind LP tank	1		7387	
Hose, 144	Pump to Jack, Left Front	2	Brown	2467	
Hose, 396	Pump to Jack, Left Rear	2	Orange	2483	
Hose, 144	Pump to Jack, Right Front	2	White	2467	
Hose, 396	Pump to Jack, Right Rear	2	Yellow	2483	
Hose, 144	Pump to synchronizing cylinder	2	Red	2467	
Hose w90, 168	Pump to Room 1	2	Green	2469	149 / Drivers side
Slide Unit	Room 1 - 18" above floor slide	1		7135	
Hose, 480	Pump to Room 2	2	Purple	2490	325 / Drivers Side
Slide Unit	Room 2 - 30" Bed slide (Lippert)	1		143960	
Hose w90, 432	Pump to Room 3	2	Gray	2486	355 / Passenger Side
Slide Unit	Room 3 - 18" above floor slide	1		7135	
Hose w90, 168	Sync cylinder to front slide, Room 4	2	Red	2469	103 / Passenger side
Hose w90, 168	Sync cylinder to rear slide, Room 4	2	Red	2469	196 / Passenger side
Slide Unit	Room 4 - 36" flush floor slide	2		7164D	
	Pump to Generator Slide	N/A			N/A
Travel Clamp	(two per slide, except the bed slide)	6		HWH	N/A

Options

Revisions

	Beginning with release of 1/23/06 and documented on ECN #3845
1	Equalizer lengthened hose....part #2415 (was too short per S. Jung email on 4/27)
2	ECN#4099 Equalizer standardize sizes & renumbers parts, 90 deg fitting ship loose
3	UPDATE JPG

**39E Presidio
EQUALIZER JACKS (FULLY AUTOMATIC)
STANDARD ON THIS UNIT**

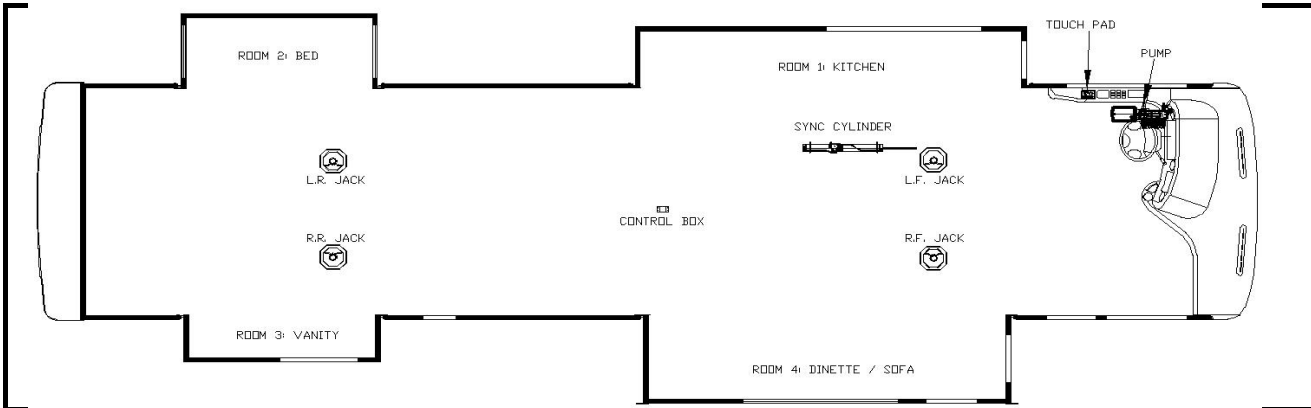

Notes:

- 1) Jacks mount to chassis brackets with the lowest holes of the jacks aligned with the lowest holes of the mounting brackets.
- 2) Level sensor attaches to bottom of structure; on the square tube the runs full length from axle to axle.
- 3) Hydraulic hose terminations for room #1, #3, & #4 require 90 degree swivel elbows.
- 4) Reference FM-3991 for a better visual of Room 4 hydraulic connections.
- 5) Hoses marked w90 will have the 90 deg fitting shipped loose.

Item, Length	Description / Location	Qty	Color	Vendor PN	
Kit	(Items listed below)	1		8315	
Pump	8-Function, 4 Rooms & Jacks	1		7302	Measuring from inside of firewall, this is the end location of the hydraulic hoses where they attach to the slide mechanism.
Jack	17,000 lbs, 18" Stroke	4		7134	
Touch Pad	Located to the left of the drivers seat	1		2318	
Control Box	Attached to bottom of structure	1		2319	
Sync Cylinder	Mounted behind LP tank	2		7397	
Hose, 144	Pump to Jack, Left Front	2	Brown	2467	
Hose, 396	Pump to Jack, Left Rear	2	Orange	2483	
Hose, 144	Pump to Jack, Right Front	2	White	2467	
Hose, 396	Pump to Jack, Right Rear	2	Yellow	2483	
Hose, 144	Pump to synchronizing cylinder	2	Green	2467	
Hose, 144	Pump to synchronizing cylinder	2	Red	2467	Mounts to bracket on structure
Hose, 480	Pump to Room 2	2	Purple	2490	325 / Drivers Side
Slide Unit	Room 2 - 30" Bed slide (Lippert)	1		143960	
Hose w90, 432	Pump to Room 3	2	Gray	2486	355 / Passenger Side
Slide Unit	Room 3 - 18" above floor slide	1		7135	
Hose w90, 168	Sync cylinder to front slide, Room 1	2	Green	2469	95 / Drivers Side
Hose w90, 168	Sync cylinder to rear slide, Room 1	2	Green	2469	180 / Drivers Side
Slide Unit	Room 1 - 24" flush floor slide	2		7369	
Hose w90, 168	Sync cylinder to front slide, Room 4	2	Red	2469	103 / Passenger side
Hose w90, 168	Sync cylinder to rear slide, Room 4	2	Red	2469	196 / Passenger side
Slide Unit	Room 4 - 24" flush floor slide	2		7369	
	Pump to Generator Slide	N/A			N/A
Travel Clamp	(two per slide, except the bed slide)	6		HWH	N/A

Options

Revisions

1	ECN#4099 Equalizer standardize sizes & renubmers parts, 90 deg fitting ship loose
2	UPDATE JPG
3	Updated per ECN #4237
3	Added equalizer slide units to chart ECN# 4438

**39F Presidio
EQUALIZER JACKS (FULLY AUTOMATIC)
STANDARD ON THIS UNIT**

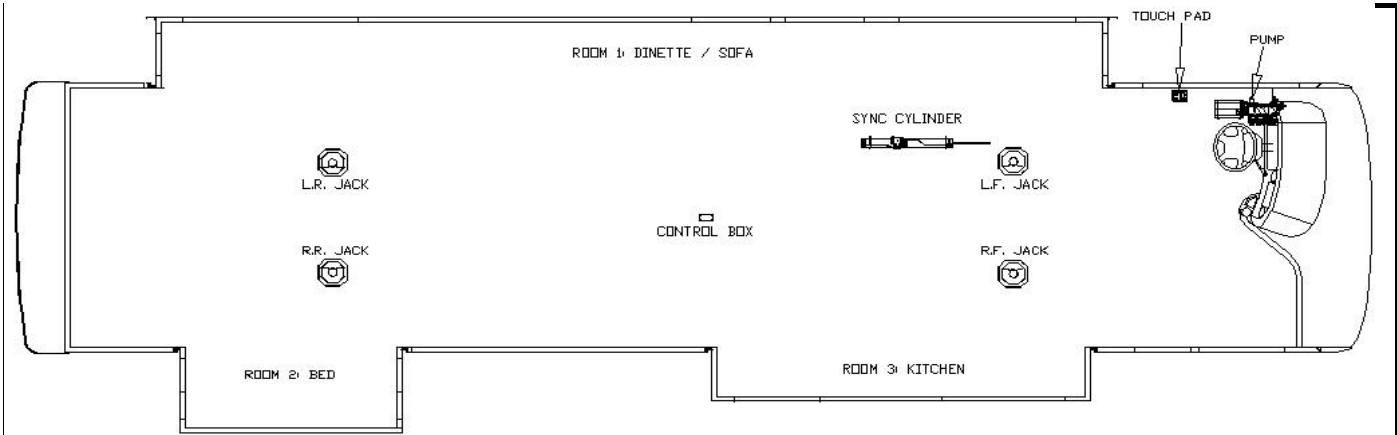

- Notes:**
- 1) Jacks mount to chassis brackets with the lowest holes of the jacks aligned with the lowest holes of the mounting brackets.
 - 2) Level sensor attaches to bottom of structure; on the square tube the runs full length from axle to axle.
 - 3) Hydraulic hose terminations for room #1 & #2 require 90 degree swivel elbows.
 - 4) Room #1 will have a non-powered slide mechanism in center of room
 - 5) Hoses marked w90 will have the 90 deg fitting shipped loose.

Item, Length	Description / Location	Qty	Color	Vendor PN	
Kit	(Items listed below)	1		8340	
Pump	7-Function, 4 Rooms & Jacks	1		7319	
Jack	17,000 lbs, 18" Stroke	4		7134	
Touch Pad	Located to the left of the drivers seat	1		2318	
Control Box	Attached to bottom of structure	1		2319	
Sync Cylinder	Mounted behind LP tank	1		7397	
Hose, 144	Pump to Jack, Left Front	2	Brown	2467	
Hose, 396	Pump to Jack, Left Rear	2	Orange	2483	
Hose, 144	Pump to Jack, Right Front	2	White	2467	
Hose, 420	Pump to Jack, Right Rear	2	Yellow	2485	
Hose, 144	Pump to synchronizing cylinder	2	Green	2467	Mounts to bracket on structure
Hose w90, 432	Sync cylinder to front slide, Room 1	2	Green	2486	103 / Drivers side
Hose w90, 432	Sync cylinder to rear slide, Room 1	2	Green	2486	350 / Drivers side
Slide Unit	Room 1 - 24" flush floor slide (angled)	2		7388	
Slide Unit	Room 1 - 24" flush floor slide (angled)	1		7384	Slave
Hose, 480	Pump to Room 2	2	Purple	2490	345 / Drivers Side
Slide Unit	Room 2 - 30" Bed slide (Lippert)	1		143960	
Hose w90, 228	Pump to Room 3	2	Gray	2474	146 / Passenger Side
Slide Unit	Room 3 - 18" above floor slide	1		7135	
	Pump to Generator Slide	N/A			N/A
Travel Clamp	(two per slide, except the bed slide)	4		HWH	N/A
Options					

Revisions					
1	UPDATE JPG				
2	Updated per ECN #4237				
3	Added equalizer slide units to chart ECN# 4438				

**39G Presidio
EQUALIZER JACKS (FULLY AUTOMATIC)
STANDARD ON THIS UNIT**

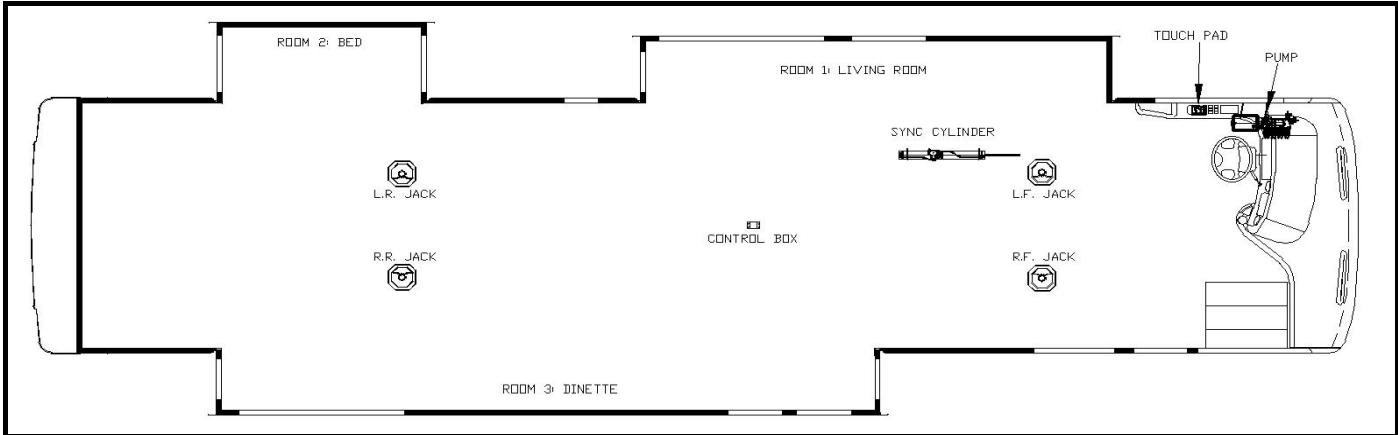

Notes:

- 1) Jacks mount to chassis brackets with the lowest holes of the jacks aligned with the lowest holes of the mounting brackets.
- 2) Level sensor attaches to bottom of structure; on the square tube the runs full length from axle to axle.
- 3) Hydraulic hose terminations for room #1 & #2 require 90 degree swivel elbows.
- 4) Room #1 will have a non-powered slide mechanism in center of room
- 5) Hoses marked w90 will have the 90 deg fitting shipped loose.

Item, Length	Description / Location	Qty	Color	Vendor PN	
Kit	(Items listed below)	1		8354	
Pump	7-Function, 3 Rooms & Jacks	1		7319	
Jack	17,000 lbs, 18" Stroke	4		7134	
Touch Pad	Located to the left of the drivers seat	1		2318	
Control Box	Attached to bottom of structure	1		2319	
Sync Cylinder	Mounted behind LP tank	2		7397	
Hose, 144	Pump to Jack, Left Front	2	Brown	2467	
Hose, 408	Pump to Jack, Left Rear	2	Orange	2484	
Hose, 144	Pump to Jack, Right Front	2	White	2467	
Hose, 408	Pump to Jack, Right Rear	2	Yellow	2484	
Hose, 144	Pump to synchronizing cylinder	2	Green	2467	Mounts to bracket on structure
Hose w90, 168	Sync cylinder to front slide, Room 1	2	Green	2469	103 / Drivers side
Hose w90, 168	Sync cylinder to rear slide, Room 1	2	Green	2469	205 / Drivers side
Slide Unit	Room 1 - 24" flush floor slide (angled)	2		7388	
Hose w90, 360	Sync cylinder to front slide, Room 3	2	Gray	2527	205 / Passenger side
Hose w90, 360	Sync cylinder to rear slide, Room 3	2	Gray	2527	350 / Passenger side
Slide Unit	Room 3 - 24" flush floor slide (angled)	2		7388	
Hose, 480	Pump to Room 2	2	Purple	2490	345 / Drivers Side
Slide Unit	Room 2 - 30" Bed slide (Lippert)	1		143960	
	Pump to Generator Slide	N/A			N/A
Travel Clamp	(two per slide, except the bed slide)	4		HWH	N/A
Hose, 144	Pump to synchronizing cylinder	2	Gray	2467	Mounts to bracket on structure

Options

Revisions

1	Corrected picture
2	Corrected hose notes for room #3 & #1.....3-5-07
3	Added equalizer slide units to chart ECN# 4438

**42A Presidio
EQUALIZER JACKS (FULLY AUTOMATIC)
STANDARD ON THIS UNIT**

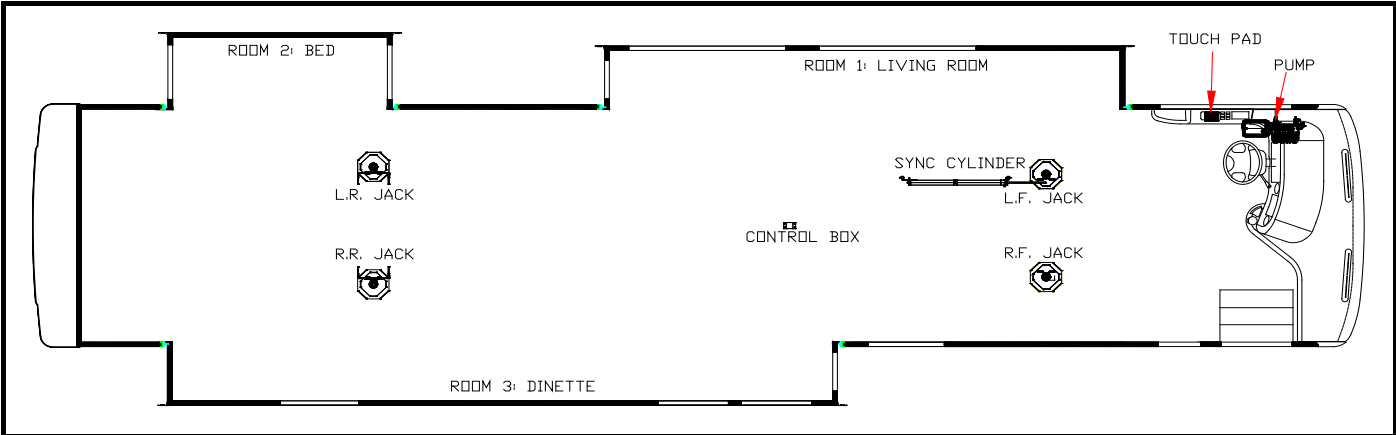

Notes:

- 1) Jacks mount to chassis brackets with the lowest holes of the jacks aligned with the lowest holes of the mounting brackets.
- 2) Level sensor attaches to bottom of structure; on the square tube the runs full length from axle to axle.
- 3) Hydraulic hose terminations for room #1 & #3 require 90 degree swivel elbows.
- 4) Hoses marked w90 will have the 90 deg fitting shipped loose.

Item, Length	Description / Location	Qty	Color	Vendor PN		
Kit	(Items listed below)	1		8373	Measuring from inside of firewall, this is the end location of the hydraulic hoses where they attach to the slide mechanism. Mounts to bracket on structure	
Pump	7-Function, 3 Rooms & Jacks	1		7319BR		
Jack	17,000 lbs, 18" Stroke	4		7134		
Touch Pad	Located to the left of the drivers seat	1		2318		
Control Box	Attached to bottom of structure	1		2730		
Sync Cylinder	Mounted behind LP tank	2		7397		
Hose, 144	Pump to Jack, Left Front	2	Brown	2467		
Hose, 408	Pump to Jack, Left Rear	2	Orange	2484		
Hose, 144	Pump to Jack, Right Front	2	White	2467		
Hose, 408	Pump to Jack, Right Rear	2	Yellow	2484		
Hose, 168	Pump to synchronizing cylinder	2	Green	2469		
Hose w90, 168	Sync cylinder to front slide, Room 1	2	Green	2469		130 / Drivers side
Hose w90, 168	Sync cylinder to rear slide, Room 1	2	Green	2469		220 / Drivers side
Slide Unit	Room 1 - 24" flush floor slide (angled)	2		7388		
Hose w90, 360	Sync cylinder to front slide, Room 3	2	Gray	2527		235 / Passenger side
Hose w90, 360	Sync cylinder to rear slide, Room 3	2	Gray	2527		385 / Passenger side
Slide Unit	Room 3 - 24" flush floor slide (angled)	2		7388		
Hose, 516	Pump to Room 2	2	Purple	2491		420 / Drivers Side
Slide Unit	Room 2 - 30" Bed slide (Lippert)	1		143960		
	Pump to Generator Slide	N/A			N/A	
Travel Clamp	(two per slide, except the bed slide)	4		HWH	N/A	
Hose, 168	Pump to synchronizing cylinder	2	Gray	2469	Mounts to bracket on structure	

Options

Revisions

36B Presidio
EQUALIZER JACKS (FULLY AUTOMATIC)
STANDARD ON THIS UNIT

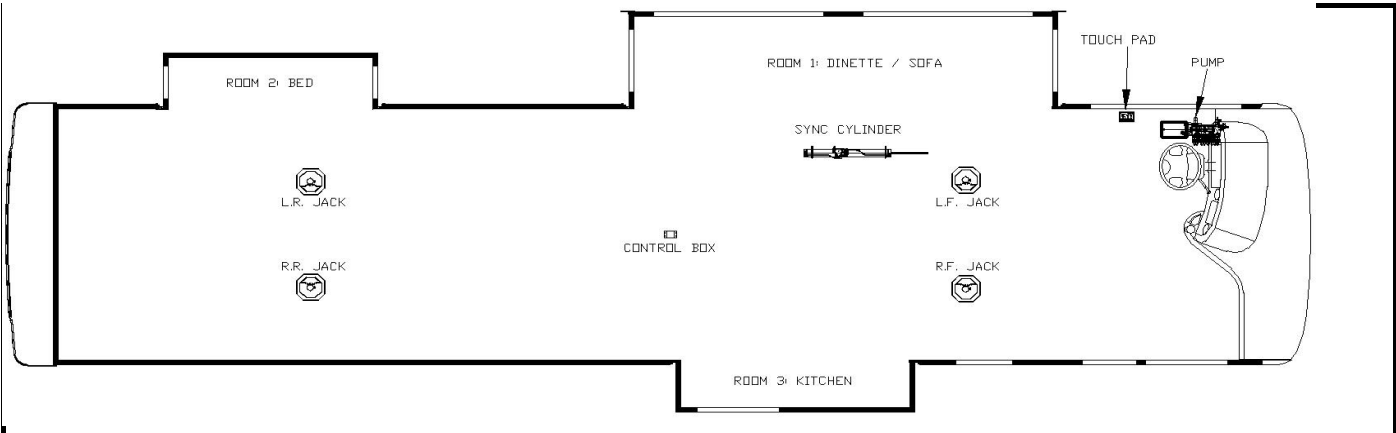

Notes:

- 1) Jacks mount to chassis brackets with the lowest holes of the jacks aligned with the lowest holes of the mounting brackets.
- 2) Level sensor attaches to bottom of structure; on lower hat section flanges or square tube.
- 3) Hydraulic hose terminations for room #1 & #3 require 90 degree swivel elbows.
- 4) Reference FM-3991 for a better visual of Room 1 hydraulic connections.
- 5) Hoses marked w90 will have the 90 deg fitting shipped loose.

Item, Length	Description / Location	Qty	Color	Vendor PN		
Kit	(Items listed below)	1		8310		
Pump	7-Function, 3 Rooms & Jacks	1		7319BR	Measuring from inside of firewall, this is the end location of the hydraulic hoses where they attach to the slide mechanism.	
Jack	17,000 lbs, 18" Stroke	4		7134		
Touch Pad	Located to the left of the drivers seat	1		2318		
Control Box	Attached to bottom of structure	1		2730		
Sync Cylinder	Mounted behind LP tank	1		7387		
Hose, 132	Pump to Jack, Left Front	2	Brown	2466		
Hose, 372	Pump to Jack, Left Rear	2	Orange	2481		
Hose, 144	Pump to Jack, Right Front	2	White	2467		
Hose, 372	Pump to Jack, Right Rear	2	Yellow	2481		
Hose, 144	Pump to synchronizing manifold	2	Green	2467		Mounts to bracket on structure
Hose w90, 168	Sync cylinder to front slide, Room 1	2	Green	2469		103 / Drivers side
Hose w90, 168	Sync cylinder to rear slide, Room 1	2	Green	2469		196 / Drivers side
	Pump to Room 1	N/A	Green			
Slide Unit	Room 1 - 36" flush floor slide	2		7164D		
Hose, 420	Pump to Room 2	2	Purple	2485	325 / Drivers Side	
Slide Unit	Room 2 - 30" Bed slide (Lippert)	1		134998		
Hose w90, 204	Pump to Room 3	2	Red	2472	146 / Passenger Side	
Slide Unit	Room 3 - 18" above floor slide	1		7135		
	Pump to Generator Slide	N/A			N/A	
Travel Clamp	(two per slide, except the bed slide)	4		HWH	N/A	

Options

Revisions

1	Added equalizer slide units to chart ECN# 4438				
2	Corrected bed slide Vendor Part No. Was 143960		JS 8-15-07		

**38C Presidio
EQUALIZER JACKS (FULLY AUTOMATIC)
STANDARD ON THIS UNIT**

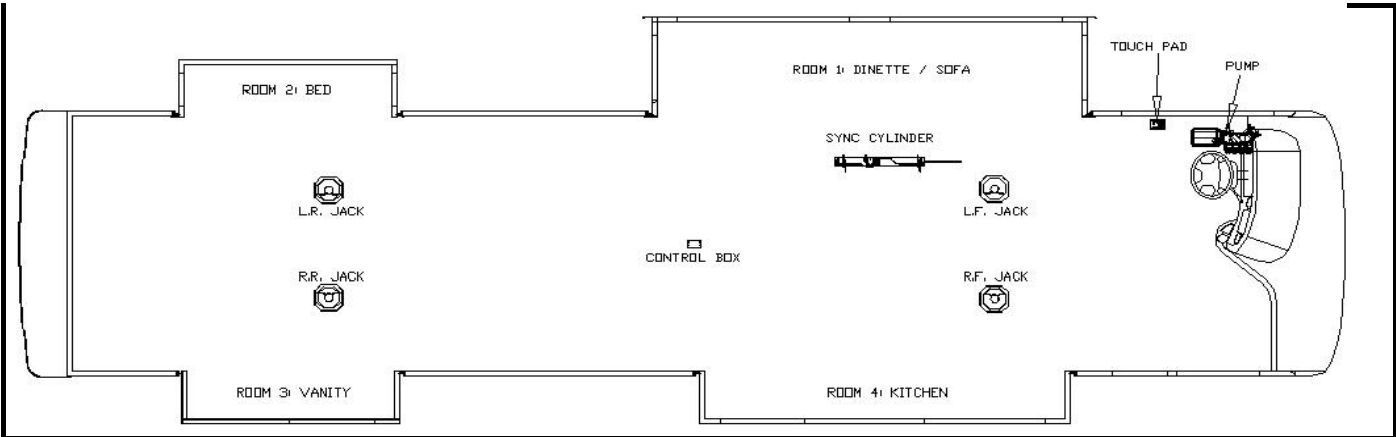

Notes:

- 1) Jacks mount to chassis brackets with the lowest holes of the jacks aligned with the lowest holes of the mounting brackets.
- 2) Level sensor attaches to bottom of structure; on lower hat section flanges or square tube.
- 3) Hydraulic hose terminations for room #1, #3, & #4 require 90 degree swivel elbows.
- 4) Reference FM-3991 for a better visual of Room 1 hydraulic connections.
- 5) Hoses marked w90 will have the 90 deg fitting shipped loose.

Item, Length	Description / Location	Qty	Color	Vendor PN	
Kit	(Items listed below)	1		8278	
Pump	8-Function, 4 Rooms & Jacks	1		7302BR	
Jack	17,000 lbs, 18" Stroke	4		7134	
Touch Pad	Located to the left of the drivers seat	1		2318	
Control Box	Attached to bottom of structure	1		2730	
Sync Cylinder	Mounted behind LP tank	1		7387	
Hose, 132	Pump to Jack, Left Front	2	Brown	2466	
Hose, 372	Pump to Jack, Left Rear	2	Orange	2481	
Hose, 144	Pump to Jack, Right Front	2	White	2467	
Hose, 372	Pump to Jack, Right Rear	2	Yellow	2481	
Hose, 144	Pump to synchronizing manifold	2	Green	2467	
Hose w90, 168	Sync cylinder to front slide, Room 1	2	Green	2469	Mounts to bracket on structure 103 / Drivers side
Hose w90, 168	Sync cylinder to rear slide, Room 1	2	Green	2469	196 / Drivers side
	Pump to Room 1	N/A	Green		
Slide Unit	Room 1 - 36" flush floor slide	2		7164D	
Hose, 420	Pump to Room 2	2	Purple	2485	325 / Drivers Side
Slide Unit	Room 2 - 30" Bed slide (Lippert)	1		134998	
Hose w90, 456	Pump to Room 3	2	Gray	2488	355 / Passenger Side
Slide Unit	Room 3 - 18" above floor slide	1		7135	
Hose w90, 204	Pump to Room 4	2	Red	2472	146 / Passenger Side
Slide Unit	Room 4 - 18" above floor slide	1		7135	
	Pump to Generator Slide	N/A			N/A
Travel Clamp	(two per slide, except the bed slide)	6		HWH	N/A
Options					
Revisions					
1	Added equalizer slide units to chart ECN# 4438				
2	Corrected bed slide Vendor Part No. Was 143960		JS 8-15-07		

**38D Presidio
EQUALIZER JACKS (FULLY AUTOMATIC)
STANDARD ON THIS UNIT**

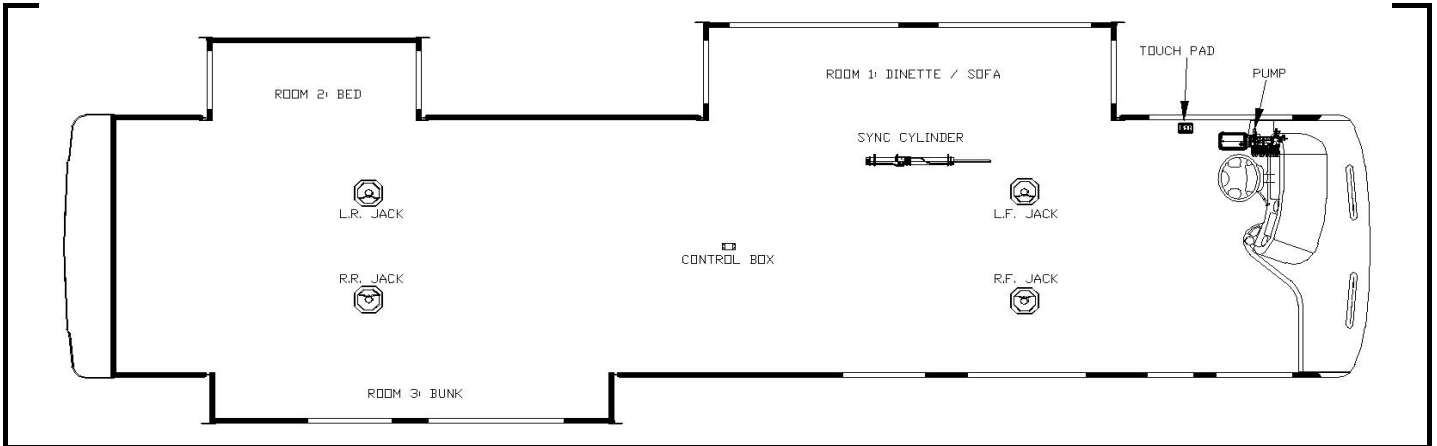

- Notes:**
- 1) Jacks mount to chassis brackets with the lowest holes of the jacks aligned with the lowest holes of the mounting brackets.
 - 2) Level sensor attaches to bottom of structure; on lower hat section flanges or square tube.
 - 3) Hydraulic hose terminations for room #1 & #3 require 90 degree swivel elbows.
 - 4) Reference FM-3991 for a better visual of Room 1 hydraulic connections.
 - 5) Hoses marked w90 will have the 90 deg fitting shipped loose.

Item, Length	Description / Location	Qty	Color	Vendor PN	
Kit	(Items listed below)	1		8347	
Pump	7-Function, 3 Rooms & Jacks	1		7319BR	
Jack	17,000 lbs, 18" Stroke	4		7134	
Touch Pad	Located to the left of the drivers seat	1		2318	
Control Box	Attached to bottom of structure	1		2730	
Sync Cylinder	Mounted behind LP tank	1		7387	
Hose, 132	Pump to Jack, Left Front	2	Brown	2466	
Hose, 372	Pump to Jack, Left Rear	2	Orange	2481	
Hose, 144	Pump to Jack, Right Front	2	White	2467	
Hose, 384	Pump to Jack, Right Rear	2	Yellow	2482	
Hose, 144	Pump to synchronizing manifold	2	Green	2467	Mounts to bracket on structure
Hose w90, 168	Sync cylinder to front slide, Room 1	2	Green	2469	103 / Drivers side
Hose w90, 168	Sync cylinder to rear slide, Room 1	2	Green	2469	196 / Drivers side
	Pump to Room 1	N/A	Green		
Slide Unit	Room 1 - 36" flush floor slide	2		7164D	
Hose, 432	Pump to Room 2	2	Purple	2486	325 / Drivers Side
Slide Unit	Room 2 - 30" Bed slide (Lippert)	1		134998	
Hose w90, 456	Pump to Room 3	2	Gray	2488	355 / Passenger Side
Slide Unit	Room 3 - 18" above floor slide	1		7135	
	Pump to Generator Slide	N/A			
Travel Clamp	(two per slide, dinette / sofa slide only)	2		HWH	N/A

Measuring from inside of firewall, this is the end location of the hydraulic hoses where they attach to the slide mechanism.

Options

Revisions

1	Added equalizer slide units to chart ECN# 4438	
2	Corrected bed slide Vendor Part No. Was 143960	JS 8-15-07

**38E Presidio
EQUALIZER JACKS (FULLY AUTOMATIC)
STANDARD ON THIS UNIT**

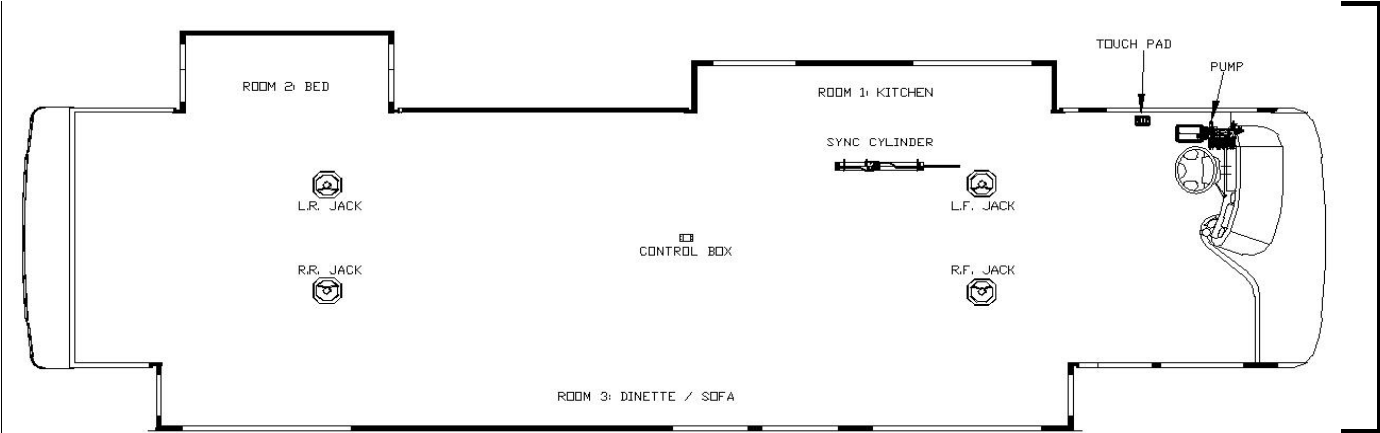

- 1) Jacks mount to chassis brackets with the lowest holes of the jacks aligned with the lowest holes of the mounting brackets.
- 2) Level sensor attaches to bottom of structure; on the square tube the runs full length from axle to axle.
- 3) Hydraulic hose terminations for room #2 & #3 require 90 degree swivel elbows.
- 4) Room #3 will have a non-powered slide mechanism in center of room
- 5) Hoses marked w90 will have the 90 deg fitting shipped loose.

Item, Length	Description / Location	Qty	Color	Vendor PN	
Kit	(Items listed below)	1		8350	
Pump	7-Function, 4 Rooms & Jacks	1		7319BR	Measuring from inside of firewall, this is the end location of the hydraulic hoses where they attach to the slide mechanism.
Jack	17,000 lbs, 18" Stroke	4		7134	
Touch Pad	Located to the left of the drivers seat	1		2318	
Control Box	Attached to bottom of structure	1		2730	
Sync Cylinder	Mounted behind LP tank	1		7397	
Hose, 144	Pump to Jack, Left Front	2	Brown	2467	
Hose, 396	Pump to Jack, Left Rear	2	Orange	2483	
Hose, 144	Pump to Jack, Right Front	2	White	2467	
Hose, 396	Pump to Jack, Right Rear	2	Yellow	2483	
Hose, 144	Pump to synchronizing cylinder	2	Green	2467	
Hose w90, 432	Sync cylinder to front slide, Room 3	2	Green	2486	103 / Drivers side
Hose w90, 432	Sync cylinder to rear slide, Room 3	2	Green	2486	350 / Drivers side
Slide Unit	Room 3 - 24" flush floor slide (angled)	2		7388	
Slide Unit	Room 3 - 24" flush floor slide (angled)	1		7384	Slave
	Pump to Room 1	N/A	Green		
Hose w90, 180	Pump to Room 1	2	Green	2470	146 / Passenger Side
Slide Unit	Room 1 - 18" above floor slide	1		7135	
Hose, 480	Pump to Room 2	2	Gray	2490	345 / Drivers Side
Slide Unit	Room 2 - 30" Bed slide (Lippert)	1		134998	
	Pump to Generator Slide	N/A			N/A
Travel Clamp	(two per slide, except the bed slide)	4		HWH	N/A
Options					

Revisions	
1	Added equalizer slide units to chart ECN# 4438
2	Corrected bed slide Vendor Part No. Was 143960 JS 8-15-07

**39B Presidio
EQUALIZER JACKS (FULLY AUTOMATIC)
STANDARD ON THIS UNIT**

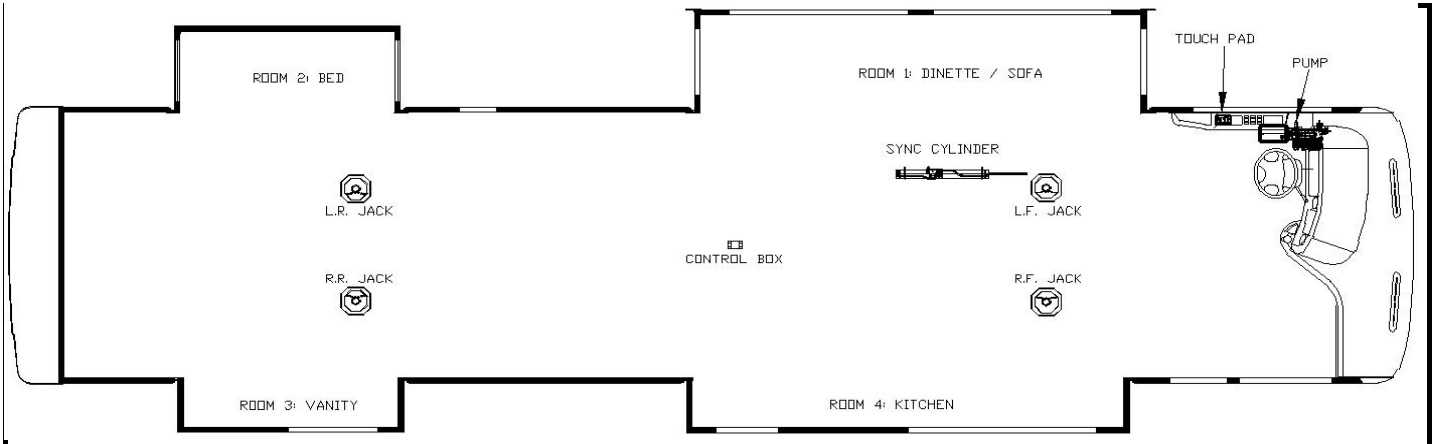

Notes:

- 1) Jacks mount to chassis brackets with the lowest holes of the jacks aligned with the lowest holes of the mounting brackets.
- 2) Level sensor attaches to bottom of structure; on the square tube the runs full length from axle to axle.
- 3) Hydraulic hose terminations for room #1, #3, & #4 require 90 degree swivel elbows.
- 4) Reference FM-3991 for a better visual of Room 1 hydraulic connections.
- 5) Hoses marked w90 will have the 90 deg fitting shipped loose.

Item, Length	Description / Location	Qty	Color	Vendor PN	
Kit	(Items listed below)	1		8294	
Pump	8-Function, 4 Rooms & Jacks	1		7302BR	Measuring from inside of firewall, this is the end location of the hydraulic hoses where they attach to the slide mechanism.
Jack	17,000 lbs, 18" Stroke	4		7134	
Touch Pad	Located to the left of the drivers seat	1		2318	
Control Box	Attached to bottom of structure	1		2730	
Sync Cylinder	Mounted behind LP tank	1		7387	
Hose, 144	Pump to Jack, Left Front	2	Brown	2467	
Hose, 396	Pump to Jack, Left Rear	2	Orange	2483	
Hose, 144	Pump to Jack, Right Front	2	White	2467	
Hose, 396	Pump to Jack, Right Rear	2	Yellow	2483	
Hose, 144	Pump to synchronizing cylinder	2	Green	2467	
Hose w90, 168	Sync cylinder to front slide, Room 1	2	Green	2469	Mounts to bracket on structure 103 / Drivers side
Hose w90, 168	Sync cylinder to rear slide, Room 1	2	Green	2469	196 / Drivers side
	Pump to Room 1	N/A	Green		
Slide Unit	Room 1 - 36" flush floor slide	2		7164D	
Hose, 480	Pump to Room 2	2	Purple	2490	340 / Drivers Side
Slide Unit	Room 2 - 30" Bed slide (Lippert)	1		134998	
Hose w90, 432	Pump to Room 3	2	Gray	2486	365 / Passenger Side
Slide Unit	Room 3 - 18" above floor slide	1		7135	
Hose w90, 228	Pump to Room 4	2	Red	2474	155 / Passenger Side
Slide Unit	Room 4 - 18" above floor slide	1		7135	
	Pump to Generator Slide	N/A			N/A
Travel Clamp	(two per slide, except the bed slide)	6		HWH	N/A

Options

Revisions

	Beginning with release of 1/23/06 and documented on ECN #3845
1	ECN#4099 Equalizer standardize sizes & renumbers parts, 90 deg fitting ship loose
2	UPDATE JPG
3	Updated per ECN #4237

39D Presidio
EQUALIZER JACKS (FULLY AUTOMATIC)
STANDARD ON THIS UNIT

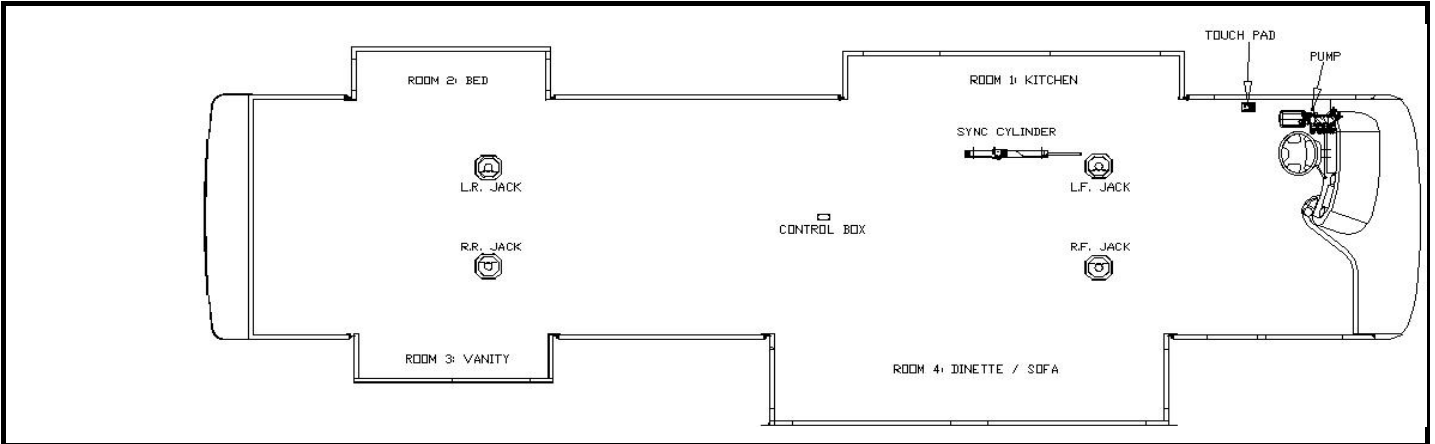

Notes:

- 1) Jacks mount to chassis brackets with the lowest holes of the jacks aligned with the lowest holes of the mounting brackets.
- 2) Level sensor attaches to bottom of structure; on the square tube the runs full length from axle to axle.
- 3) Hydraulic hose terminations for room #1, #3, & #4 require 90 degree swivel elbows.
- 4) Reference FM-3991 for a better visual of Room 4 hydraulic connections.
- 5) Hoses marked w90 will have the 90 deg fitting shipped loose.

Item, Length	Description / Location	Qty	Color	Vendor PN	
Kit	(Items listed below)	1		8292	
Pump	8-Function, 4 Rooms & Jacks	1		7302BR	Measuring from inside of firewall, this is the end location of the hydraulic hoses where they attach to the slide mechanism.
Jack	17,000 lbs, 18" Stroke	4		7134	
Touch Pad	Located to the left of the drivers seat	1		2318	
Control Box	Attached to bottom of structure	1		2730	
Sync Cylinder	Mounted behind LP tank	1		7387	
Hose, 144	Pump to Jack, Left Front	2	Brown	2467	
Hose, 396	Pump to Jack, Left Rear	2	Orange	2483	
Hose, 144	Pump to Jack, Right Front	2	White	2467	
Hose, 396	Pump to Jack, Right Rear	2	Yellow	2483	
Hose, 144	Pump to synchronizing cylinder	2	Red	2467	
Hose w90, 168	Pump to Room 1	2	Green	2469	Mounts to bracket on structure 149 / Drivers side
Slide Unit	Room 1 - 18" above floor slide	1		7135	
Hose, 480	Pump to Room 2	2	Purple	2490	325 / Drivers Side
Slide Unit	Room 2 - 30" Bed slide (Lippert)	1		134998	
Hose w90, 432	Pump to Room 3	2	Gray	2486	355 / Passenger Side
Slide Unit	Room 3 - 18" above floor slide	1		7135	
Hose w90, 168	Sync cylinder to front slide, Room 4	2	Red	2469	103 / Passenger side
Hose w90, 168	Sync cylinder to rear slide, Room 4	2	Red	2469	196 / Passenger side
Slide Unit	Room 4 - 36" flush floor slide	2		7164D	
	Pump to Generator Slide	N/A			N/A
Travel Clamp	(two per slide, except the bed slide)	6		HWH	N/A

Options

Revisions

	Beginning with release of 1/23/06 and documented on ECN #3845
1	Equalizer lengthened hose....part #2415 (was too short per S. Jung email on 4/27)
2	ECN#4099 Equalizer standardize sizes & renumbers parts, 90 deg fitting ship loose
3	UPDATE JPG

**39E Presidio
EQUALIZER JACKS (FULLY AUTOMATIC)
STANDARD ON THIS UNIT**

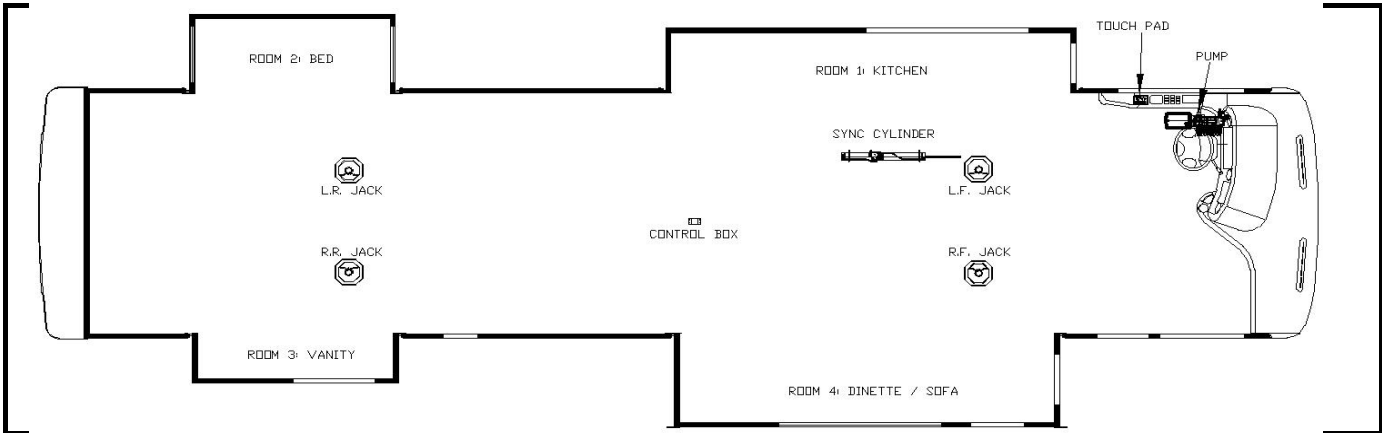

Notes:

- 1) Jacks mount to chassis brackets with the lowest holes of the jacks aligned with the lowest holes of the mounting brackets.
- 2) Level sensor attaches to bottom of structure; on the square tube the runs full length from axle to axle.
- 3) Hydraulic hose terminations for room #1, #3, & #4 require 90 degree swivel elbows.
- 4) Reference FM-3991 for a better visual of Room 4 hydraulic connections.
- 5) Hoses marked w90 will have the 90 deg fitting shipped loose.

Item, Length	Description / Location	Qty	Color	Vendor PN	
Kit	(Items listed below)	1		8315	
Pump	8-Function, 4 Rooms & Jacks	1		7302BR	Measuring from inside of firewall, this is the end location of the hydraulic hoses where they attach to the slide mechanism.
Jack	17,000 lbs, 18" Stroke	4		7134	
Touch Pad	Located to the left of the drivers seat	1		2318	
Control Box	Attached to bottom of structure	1		2730	
Sync Cylinder	Mounted behind LP tank	2		7397	
Hose, 144	Pump to Jack, Left Front	2	Brown	2467	
Hose, 396	Pump to Jack, Left Rear	2	Orange	2483	
Hose, 144	Pump to Jack, Right Front	2	White	2467	
Hose, 396	Pump to Jack, Right Rear	2	Yellow	2483	
Hose, 144	Pump to synchronizing cylinder	2	Green	2467	
Hose, 144	Pump to synchronizing cylinder	2	Red	2467	Mounts to bracket on structure
Hose, 480	Pump to Room 2	2	Purple	2490	325 / Drivers Side
Slide Unit	Room 2 - 30" Bed slide (Lippert)	1		134998	
Hose w90, 432	Pump to Room 3	2	Gray	2486	355 / Passenger Side
Slide Unit	Room 3 - 18" above floor slide	1		7135	
Hose w90, 168	Sync cylinder to front slide, Room 1	2	Green	2469	95 / Drivers Side
Hose w90, 168	Sync cylinder to rear slide, Room 1	2	Green	2469	180 / Drivers Side
Slide Unit	Room 1 - 24" flush floor slide	2		7369	
Hose w90, 168	Sync cylinder to front slide, Room 4	2	Red	2469	103 / Passenger side
Hose w90, 168	Sync cylinder to rear slide, Room 4	2	Red	2469	196 / Passenger side
Slide Unit	Room 4 - 24" flush floor slide	2		7369	
	Pump to Generator Slide	N/A			N/A
Travel Clamp	(two per slide, except the bed slide)	6		HWH	N/A

Options

Revisions

1	ECN#4099 Equalizer standardize sizes & rennumbers parts, 90 deg fitting ship loose
2	UPDATE JPG
3	Updated per ECN #4237
3	Added equalizer slide units to chart ECN# 4438

**39F Presidio
EQUALIZER JACKS (FULLY AUTOMATIC)
STANDARD ON THIS UNIT**

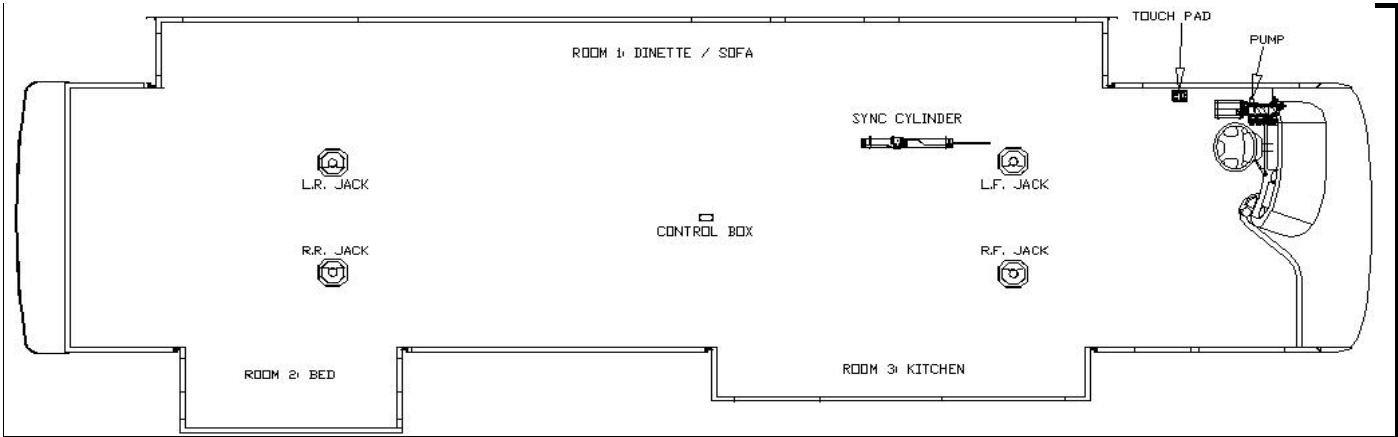

Notes:

- 1) Jacks mount to chassis brackets with the lowest holes of the jacks aligned with the lowest holes of the mounting brackets.
- 2) Level sensor attaches to bottom of structure; on the square tube the runs full length from axle to axle.
- 3) Hydraulic hose terminations for room #1 & #2 require 90 degree swivel elbows.
- 4) Room #1 will have a non-powered slide mechanism in center of room
- 5) Hoses marked w90 will have the 90 deg fitting shipped loose.

Item, Length	Description / Location	Qty	Color	Vendor PN	
Kit	(Items listed below)	1		8340	
Pump	7-Function, 4 Rooms & Jacks	1		7319BR	
Jack	17,000 lbs, 18" Stroke	4		7134	
Touch Pad	Located to the left of the drivers seat	1		2318	
Control Box	Attached to bottom of structure	1		2730	
Sync Cylinder	Mounted behind LP tank	1		7397	
Hose, 144	Pump to Jack, Left Front	2	Brown	2467	
Hose, 396	Pump to Jack, Left Rear	2	Orange	2483	
Hose, 144	Pump to Jack, Right Front	2	White	2467	
Hose, 420	Pump to Jack, Right Rear	2	Yellow	2485	
Hose, 144	Pump to synchronizing cylinder	2	Green	2467	Mounts to bracket on structure
Hose w90, 432	Sync cylinder to front slide, Room 1	2	Green	2486	103 / Drivers side
Hose w90, 432	Sync cylinder to rear slide, Room 1	2	Green	2486	350 / Drivers side
Slide Unit	Room 1 - 24" flush floor slide (angled)	2		7388	
Slide Unit	Room 1 - 24" flush floor slide (angled)	1		7384	Slave
Hose, 480	Pump to Room 2	2	Purple	2490	345 / Drivers Side
Slide Unit	Room 2 - 30" Bed slide (Lippert)	1		134998	
Hose w90, 228	Pump to Room 3	2	Gray	2474	146 / Passenger Side
Slide Unit	Room 3 - 18" above floor slide	1		7135	
	Pump to Generator Slide	N/A			N/A
Travel Clamp	(two per slide, except the bed slide)	4		HWH	N/A
Options					

Measuring from inside of firewall, this is the end location of the hydraulic hoses where they attach to the slide mechanism.

Revisions

1	UPDATE JPG		
2	Updated per ECN #4237		
3	Added equalizer slide units to chart ECN# 4438		
4	Corrected bed slide Vendor Part No. Was 143960	JS 8-15-07	

**39G Presidio
EQUALIZER JACKS (FULLY AUTOMATIC)
STANDARD ON THIS UNIT**

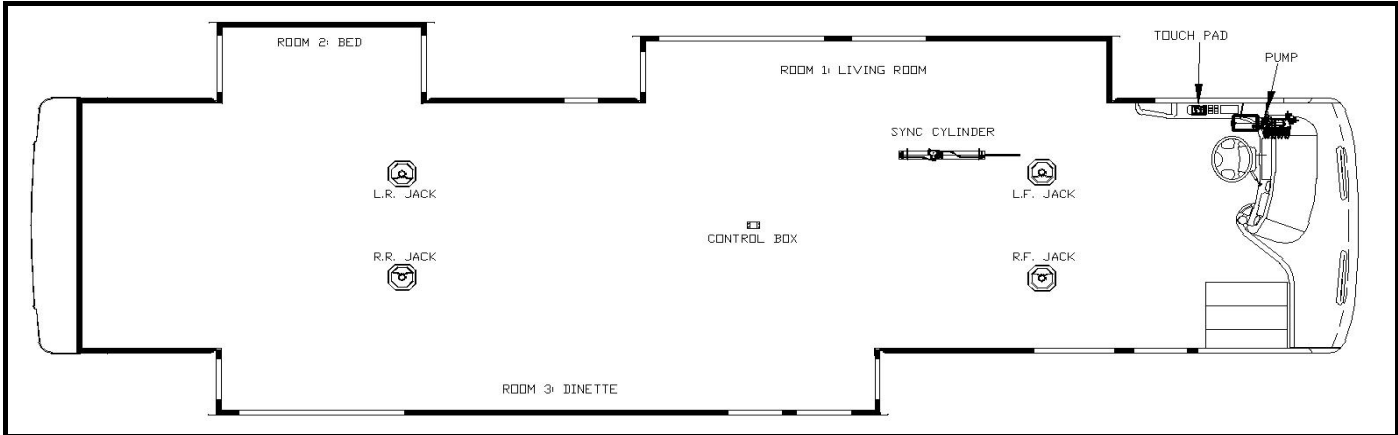

Notes:

- 1) Jacks mount to chassis brackets with the lowest holes of the jacks aligned with the lowest holes of the mounting brackets.
- 2) Level sensor attaches to bottom of structure; on the square tube the runs full length from axle to axle.
- 3) Hydraulic hose terminations for room #1 & #2 require 90 degree swivel elbows.
- 4) Room #1 will have a non-powered slide mechanism in center of room
- 5) Hoses marked w90 will have the 90 deg fitting shipped loose.

Item, Length	Description / Location	Qty	Color	Vendor PN	
Kit	(Items listed below)	1		8354	
Pump	7-Function, 3 Rooms & Jacks	1		7319BR	Measuring from inside of firewall, this is the end location of the hydraulic hoses where they attach to the slide mechanism.
Jack	17,000 lbs, 18" Stroke	4		7134	
Touch Pad	Located to the left of the drivers seat	1		2318	
Control Box	Attached to bottom of structure	1		2730	
Sync Cylinder	Mounted behind LP tank	2		7397	
Hose, 144	Pump to Jack, Left Front	2	Brown	2467	
Hose, 408	Pump to Jack, Left Rear	2	Orange	2484	
Hose, 144	Pump to Jack, Right Front	2	White	2467	
Hose, 408	Pump to Jack, Right Rear	2	Yellow	2484	
Hose, 144	Pump to synchronizing cylinder	2	Green	2467	
Hose w90, 168	Sync cylinder to front slide, Room 1	2	Green	2469	Mounts to bracket on structure 103 / Drivers side
Hose w90, 168	Sync cylinder to rear slide, Room 1	2	Green	2469	205 / Drivers side
Slide Unit	Room 1 - 24" flush floor slide (angled)	2		7388	
Hose w90, 360	Sync cylinder to front slide, Room 3	2	Gray	2527	205 / Passenger side
Hose w90, 360	Sync cylinder to rear slide, Room 3	2	Gray	2527	350 / Passenger side
Slide Unit	Room 3 - 24" flush floor slide (angled)	2		7388	
Hose, 480	Pump to Room 2	2	Purple	2490	345 / Drivers Side
Slide Unit	Room 2 - 30" Bed slide (Lippert)	1		134998	
	Pump to Generator Slide	N/A			N/A
Travel Clamp	(two per slide, except the bed slide)	4		HWH	N/A
Hose, 144	Pump to synchronizing cylinder	2	Gray	2467	Mounts to bracket on structure

Options

Revisions

1	Corrected picture
2	Corrected hose notes for room #3 & #1.....3-5-07
3	Added equalizer slide units to chart ECN# 4438
4	Corrected bed slide Vendor Part No. Was 143960 JS 8-15-07

**42A Presidio
EQUALIZER JACKS (FULLY AUTOMATIC)
STANDARD ON THIS UNIT**

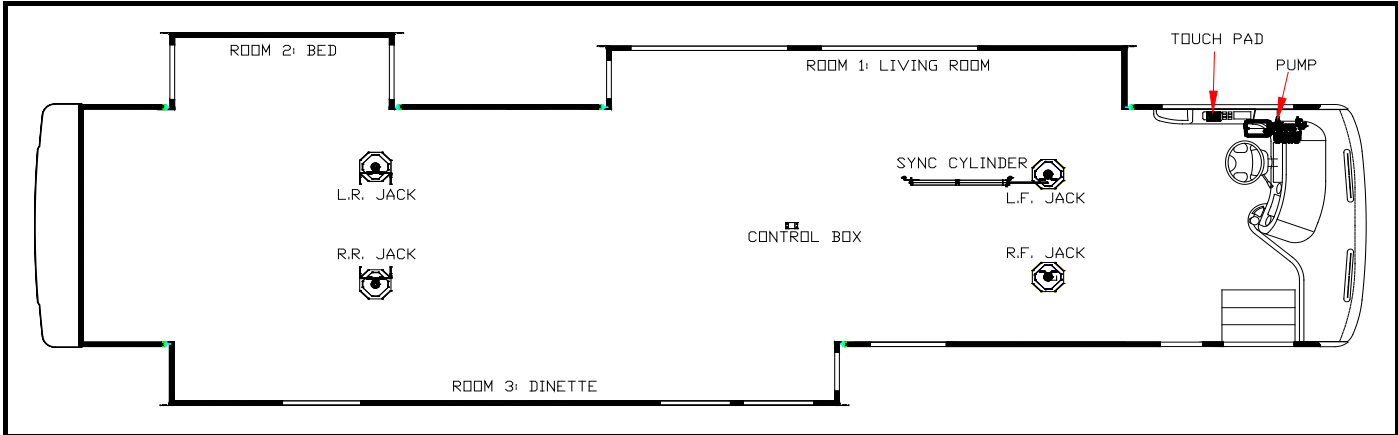

Notes:

- 1) Jacks mount to chassis brackets with the lowest holes of the jacks aligned with the lowest holes of the mounting brackets.
- 2) Level sensor attaches to bottom of structure; on the square tube the runs full length from axle to axle.
- 3) Hydraulic hose terminations for room #1 & #3 require 90 degree swivel elbows.
- 4) Hoses marked w90 will have the 90 deg fitting shipped loose.

Item, Length	Description / Location	Qty	Color	Vendor PN	
Kit	(Items listed below)	1		8373	Measuring from inside of firewall, this is the end location of the hydraulic hoses where they attach to the slide mechanism.
Pump	7-Function, 3 Rooms & Jacks	1		7319BR	
Jack	17,000 lbs, 18" Stroke	4		7134	
Touch Pad	Located to the left of the drivers seat	1		2318	
Control Box	Attached to bottom of structure	1		2730	
Sync Cylinder	Mounted behind LP tank	2		7397	
Hose, 144	Pump to Jack, Left Front	2	Brown	2467	
Hose, 408	Pump to Jack, Left Rear	2	Orange	2484	
Hose, 144	Pump to Jack, Right Front	2	White	2467	
Hose, 408	Pump to Jack, Right Rear	2	Yellow	2484	
Hose, 168	Pump to synchronizing cylinder	2	Green	2469	Mounts to bracket on structure
Hose w90, 168	Sync cylinder to front slide, Room 1	2	Green	2469	130 / Drivers side
Hose w90, 168	Sync cylinder to rear slide, Room 1	2	Green	2469	220 / Drivers side
Slide Unit	Room 1 - 24" flush floor slide (angled)	2		7388	
Hose w90, 360	Sync cylinder to front slide, Room 3	2	Gray	2527	235 / Passenger side
Hose w90, 360	Sync cylinder to rear slide, Room 3	2	Gray	2527	385 / Passenger side
Slide Unit	Room 3 - 24" flush floor slide (angled)	2		7388	
Hose, 516	Pump to Room 2	2	Purple	2491	420 / Drivers Side
Slide Unit	Room 2 - 30" Bed slide (Lippert)	1		134998	
	Pump to Generator Slide	N/A			N/A
Travel Clamp	(two per slide, except the bed slide)	4		HWH	N/A
Hose, 168	Pump to synchronizing cylinder	2	Gray	2469	Mounts to bracket on structure

Options

Revisions

1	Updated before intial quote.	JES 8-9-07	
2	Corrected bed slide Vendor Part No. Was 143960	JS 8-15-07	

42B Presidio
EQUALIZER JACKS (FULLY AUTOMATIC)
STANDARD ON THIS UNIT

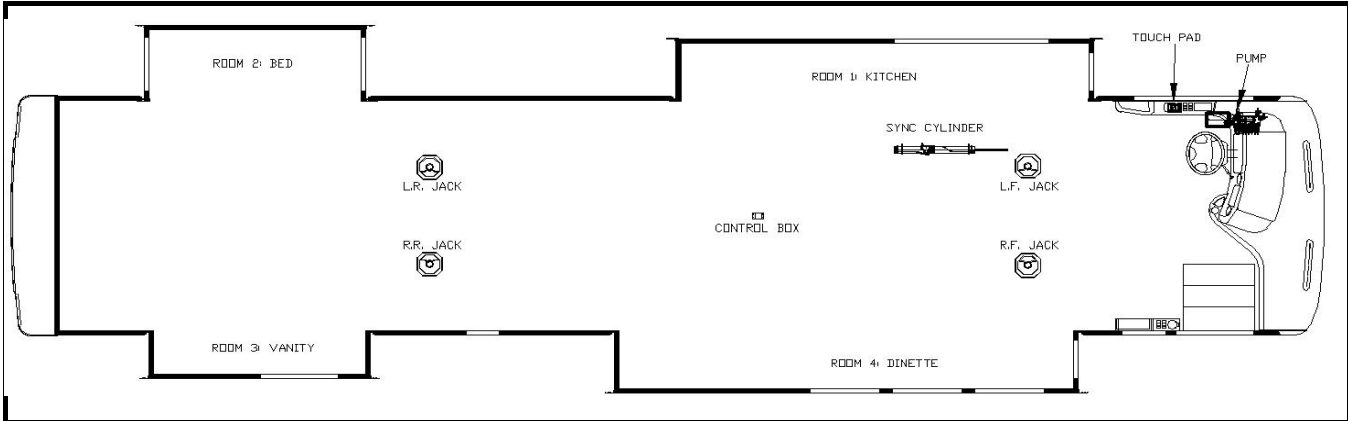

- Notes:**
- 1) Jacks mount to chassis brackets with the lowest holes of the jacks aligned with the lowest holes of the mounting brackets.
 - 2) Level sensor attaches to bottom of structure; on the square tube the runs full length from axle to axle.
 - 3) Hydraulic hose terminations for room #1 & #3 require 90 degree swivel elbows.
 - 4) Hoses marked w90 will have the 90 deg fitting shipped loose.

Item, Length	Description / Location	Qty	Color	Vendor PN	
Kit	(Items listed below)	1		8379	Measuring from inside of firewall, this is the end location of the hydraulic hoses where they attach to the slide mechanism.
Pump	8-Function, 4 Rooms & Jacks	1		7302BR	
Jack	17,000 lbs, 18" Stroke	4		7134	
Touch Pad	Located to the left of the drivers seat	1		2318	
Control Box	Attached to bottom of structure	1		2730	
Sync Cylinder	Mounted behind LP tank	2		7397	
Hose, 144	Pump to Jack, Left Front	2	Brown	2467	
Hose, 408	Pump to Jack, Left Rear	2	Orange	2484	
Hose, 144	Pump to Jack, Right Front	2	White	2467	
Hose, 408	Pump to Jack, Right Rear	2	Yellow	2484	
Hose, 168	Pump to synchronizing cylinder	2	Green	2469	Mounts to bracket on structure
Hose, 168	Pump to synchronizing cylinder	2	Red	2469	Mounts to bracket on structure
Hose w90, 168	Sync cylinder to front slide, Room 1	2	Green	2469	115 / Drivers side
Hose w90, 168	Sync cylinder to rear slide, Room 1	2	Green	2469	205 / Drivers side
Slide Unit	Room 1 - 24" flush floor slide (angled)	2		7388	
Hose, 516	Pump to Room 2	2	Purple	2491	420 / Drivers Side
Slide Unit	Room 2 - 30" Bed slide (Lippert)	1		134998	
Hose w90, 516	Pump to Room 3	2	Gray	2491	404 / Passenger side
Slide Unit	Room 3 - 18" above floor slide	1		7135	
Hose w90, 288	Sync cylinder to front slide, Room 4	2	Red	2478	115 / Passenger side
Hose w90, 288	Sync cylinder to rear slide, Room 4	2	Red	2478	254 / Passenger side
Slide Unit	Room 4 - 24" flush floor slide (angled)	2		7388	
	Pump to Generator Slide	N/A			N/A
Travel Clamp	(two per slide, except the bed slide)	6		HWH	N/A

Options

Revisions

**36B Presidio
EQUALIZER JACKS (FULLY AUTOMATIC)
STANDARD ON THIS UNIT**

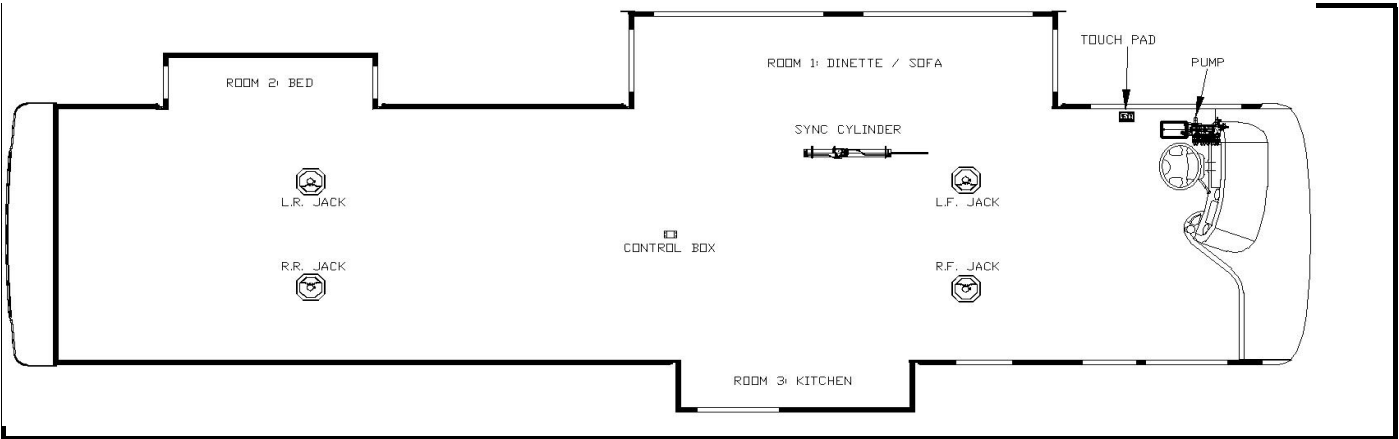

- Notes:**
- 1) Jacks mount to chassis brackets with the lowest holes of the jacks aligned with the lowest holes of the mounting brackets.
 - 2) Level sensor attaches to bottom of structure; on lower hat section flanges or square tube.
 - 3) Hydraulic hose terminations for room #1 & #3 require 90 degree swivel elbows.
 - 4) Reference FM-3991 for a better visual of Room 1 hydraulic connections.
 - 5) Hoses marked w90 will have the 90 deg fitting shipped loose.

Item, Length	Description / Location	Qty	Color	Vendor PN	
Kit	(Items listed below)	1		8310	
Pump	7-Function, 3 Rooms & Jacks	1		7319BR	Measuring from inside of firewall, this is the end location of the hydraulic hoses where they attach to the slide mechanism.
Jack	17,000 lbs, 18" Stroke	4		7134	
Touch Pad	Located to the left of the drivers seat	1		2318	
Control Box	Attached to bottom of structure	1		2730	
Sync Cylinder	Mounted behind LP tank	1		7387	
Hose, 132	Pump to Jack, Left Front	2	Brown	2466	
Hose, 372	Pump to Jack, Left Rear	2	Orange	2481	
Hose, 144	Pump to Jack, Right Front	2	White	2467	
Hose, 372	Pump to Jack, Right Rear	2	Yellow	2481	
Hose, 144	Pump to synchronizing manifold	2	Green	2467	
Hose w90, 168	Sync cylinder to front slide, Room 1	2	Green	2469	103 / Drivers side
Hose w90, 168	Sync cylinder to rear slide, Room 1	2	Green	2469	196 / Drivers side
	Pump to Room 1	N/A	Green		
Slide Unit	Room 1 - 36" flush floor slide	2		7164D	
Hose, 420	Pump to Room 2	2	Purple	2485	325 / Drivers Side
Slide Unit	Room 2 - 30" Bed slide (Lippert)	1		134998	
Hose w90, 204	Pump to Room 3	2	Red	2472	146 / Passenger Side
Slide Unit	Room 3 - 18" above floor slide	1		7135	
	Pump to Generator Slide	N/A			N/A
Travel Clamp	(two per slide, except the bed slide)	4		HWH	N/A

Options					

Revisions					
1	Added equalizer slide units to chart	ECN# 4438			
2	Corrected bed slide Vendor Part No. Was 143960		JS 8-15-07		

**38C Presidio
EQUALIZER JACKS (FULLY AUTOMATIC)
STANDARD ON THIS UNIT**

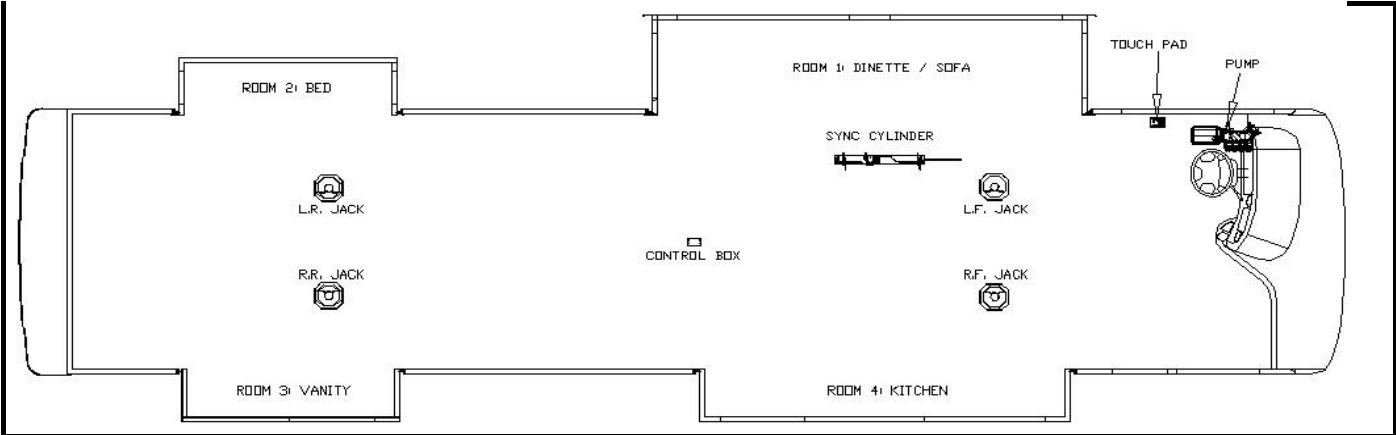

Notes:

- 1) Jacks mount to chassis brackets with the lowest holes of the jacks aligned with the lowest holes of the mounting brackets.
- 2) Level sensor attaches to bottom of structure; on lower hat section flanges or square tube.
- 3) Hydraulic hose terminations for room #1, #3, & #4 require 90 degree swivel elbows.
- 4) Reference FM-3991 for a better visual of Room 1 hydraulic connections.
- 5) Hoses marked w90 will have the 90 deg fitting shipped loose.

Item, Length	Description / Location	Qty	Color	Vendor PN		
Kit	(Items listed below)	1		8278	<p align="center">Measuring from inside of firewall, this is the end location of the hydraulic hoses where they attach to the slide mechanism.</p>	
Pump	8-Function, 4 Rooms & Jacks	1		7302BR		
Jack	17,000 lbs, 18" Stroke	4		7134		
Touch Pad	Located to the left of the drivers seat	1		2318		
Control Box	Attached to bottom of structure	1		2730		
Sync Cylinder	Mounted behind LP tank	1		7387		
Hose, 132	Pump to Jack, Left Front	2	Brown	2466		
Hose, 372	Pump to Jack, Left Rear	2	Orange	2481		
Hose, 144	Pump to Jack, Right Front	2	White	2467		
Hose, 372	Pump to Jack, Right Rear	2	Yellow	2481		
Hose, 144	Pump to synchronizing manifold	2	Green	2467		Mounts to bracket on structure
Hose w90, 168	Sync cylinder to front slide, Room 1	2	Green	2469		103 / Drivers side
Hose w90, 168	Sync cylinder to rear slide, Room 1	2	Green	2469		196 / Drivers side
	Pump to Room 1	N/A	Green			
Slide Unit	Room 1 - 36" flush floor slide	2		7164D		
Hose, 420	Pump to Room 2	2	Purple	2485		325 / Drivers Side
Slide Unit	Room 2 - 30" Bed slide (Lippert)	1		134998		
Hose w90, 456	Pump to Room 3	2	Gray	2488		355 / Passenger Side
Slide Unit	Room 3 - 18" above floor slide	1		7135		
Hose w90, 204	Pump to Room 4	2	Red	2472	146 / Passenger Side	
Slide Unit	Room 4 - 18" above floor slide	1		7135		
	Pump to Generator Slide	N/A			N/A	
Travel Clamp	(two per slide, except the bed slide)	6		HWH	N/A	
Options						
Revisions						
1	Added equalizer slide units to chart ECN# 4438					
2	Corrected bed slide Vendor Part No. Was 143960		JS 8-15-07			

**38D Presidio
EQUALIZER JACKS (FULLY AUTOMATIC)
STANDARD ON THIS UNIT**

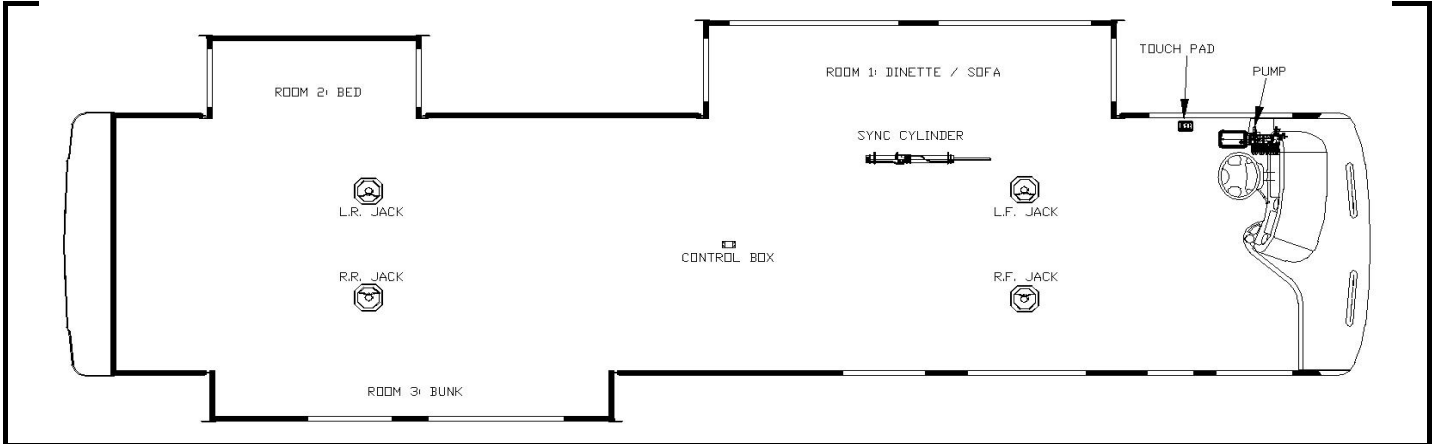

Notes:

- 1) Jacks mount to chassis brackets with the lowest holes of the jacks aligned with the lowest holes of the mounting brackets.
- 2) Level sensor attaches to bottom of structure; on lower hat section flanges or square tube.
- 3) Hydraulic hose terminations for room #1 & #3 require 90 degree swivel elbows.
- 4) Reference FM-3991 for a better visual of Room 1 hydraulic connections.
- 5) Hoses marked w90 will have the 90 deg fitting shipped loose.

Item, Length	Description / Location	Qty	Color	Vendor PN	
Kit	(Items listed below)	1		8347	
Pump	7-Function, 3 Rooms & Jacks	1		7319BR	Measuring from inside of firewall, this is the end location of the hydraulic hoses where they attach to the slide mechanism.
Jack	17,000 lbs, 18" Stroke	4		7134	
Touch Pad	Located to the left of the drivers seat	1		2318	
Control Box	Attached to bottom of structure	1		2730	
Sync Cylinder	Mounted behind LP tank	1		7387	
Hose, 132	Pump to Jack, Left Front	2	Brown	2466	
Hose, 372	Pump to Jack, Left Rear	2	Orange	2481	
Hose, 144	Pump to Jack, Right Front	2	White	2467	
Hose, 384	Pump to Jack, Right Rear	2	Yellow	2482	
Hose, 144	Pump to synchronizing manifold	2	Green	2467	
Hose w90, 168	Sync cylinder to front slide, Room 1	2	Green	2469	Mounts to bracket on structure 103 / Drivers side
Hose w90, 168	Sync cylinder to rear slide, Room 1	2	Green	2469	196 / Drivers side
	Pump to Room 1	N/A	Green		
Slide Unit	Room 1 - 36" flush floor slide	2		7164D	
Hose, 432	Pump to Room 2	2	Purple	2486	325 / Drivers Side
Slide Unit	Room 2 - 30" Bed slide (Lippert)	1		134998	
Hose w90, 456	Pump to Room 3	2	Gray	2488	355 / Passenger Side
Slide Unit	Room 3 - 18" above floor slide	1		7135	
	Pump to Generator Slide	N/A			
Travel Clamp	(two per slide, dinette / sofa slide only)	2		HWH	N/A
Options					
Revisions					
1	Added equalizer slide units to chart ECN# 4438				
2	Corrected bed slide Vendor Part No. Was 143960		JS 8-15-07		

38E Presidio
EQUALIZER JACKS (FULLY AUTOMATIC)
STANDARD ON THIS UNIT

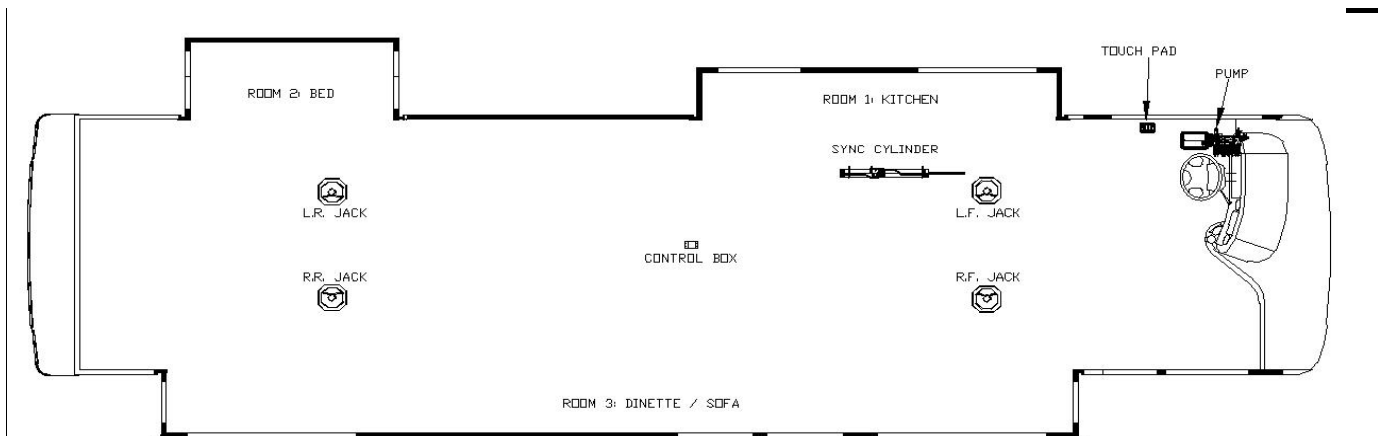

- 1) Jacks mount to chassis brackets with the lowest holes of the jacks aligned with the lowest holes of the mounting brackets.
- 2) Level sensor attaches to bottom of structure; on the square tube the runs full length from axle to axle.
- 3) Hydraulic hose terminations for room #2 & #3 require 90 degree swivel elbows.
- 4) Room #3 will have a non-powered slide mechanism in center of room
- 5) Hoses marked w90 will have the 90 deg fitting shipped loose.

Item, Length	Description / Location	Qty	Color	Vendor PN	
Kit	(Items listed below)	1		8350	
Pump	7-Function, 4 Rooms & Jacks	1		7319BR	Measuring from inside of firewall, this is the end location of the hydraulic hoses where they attach to the slide mechanism.
Jack	17,000 lbs, 18" Stroke	4		7134	
Touch Pad	Located to the left of the drivers seat	1		2318	
Control Box	Attached to bottom of structure	1		2730	
Sync Cylinder	Mounted behind LP tank	1		7397	
Hose, 144	Pump to Jack, Left Front	2	Brown	2467	
Hose, 396	Pump to Jack, Left Rear	2	Orange	2483	
Hose, 144	Pump to Jack, Right Front	2	White	2467	
Hose, 396	Pump to Jack, Right Rear	2	Yellow	2483	
Hose, 144	Pump to synchronizing cylinder	2	Gray	2467	
Hose w90, 432	Sync cylinder to front slide, Room 3	2	Gray	2486	103 / Drivers side
Hose w90, 432	Sync cylinder to rear slide, Room 3	2	Gray	2486	350 / Drivers side
Slide Unit	Room 3 - 24" flush floor slide (angled)	2		7388	
Slide Unit	Room 3 - 24" flush floor slide (angled)	1		7384	Slave
	Pump to Room 1	N/A	Green		
Hose w90, 180	Pump to Room 1	2	Green	2470	146 / Passenger Side
Slide Unit	Room 1 - 18" above floor slide	1		7135	
Hose, 480	Pump to Room 2	2	Purple	2490	345 / Drivers Side
Slide Unit	Room 2 - 30" Bed slide (Lippert)	1		134998	
	Pump to Generator Slide	N/A			N/A
Travel Clamp	(two per slide, except the bed slide)	4		HWH	N/A
Options					

Revisions					
1	Added equalizer slide units to chart	ECN# 4438			
2	Corrected bed slide Vendor Part No. Was	143960	JS 8-15-07		

**39B Presidio
EQUALIZER JACKS (FULLY AUTOMATIC)
STANDARD ON THIS UNIT**

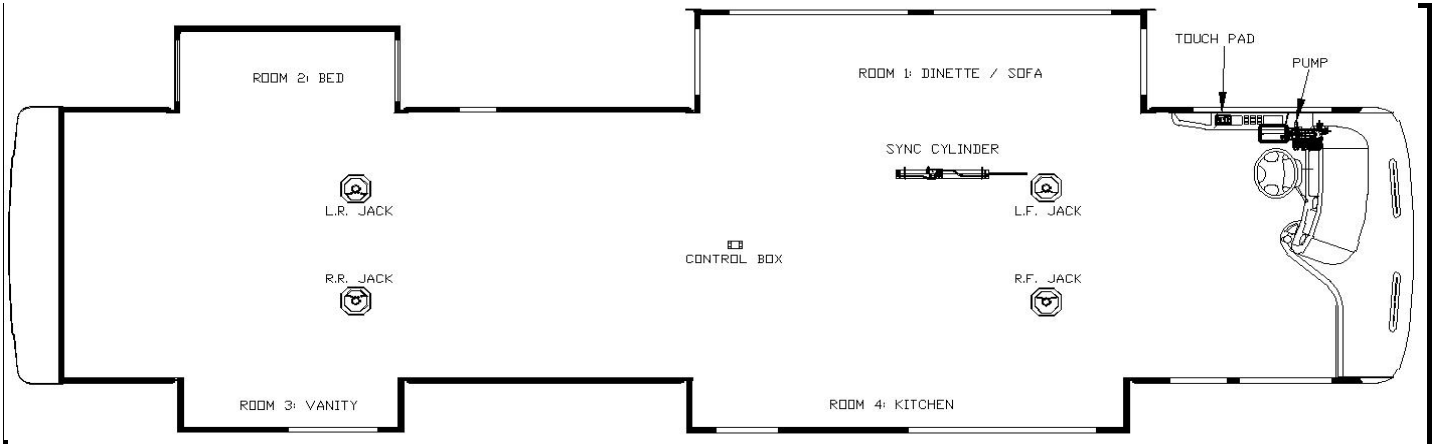

Notes:

- 1) Jacks mount to chassis brackets with the lowest holes of the jacks aligned with the lowest holes of the mounting brackets.
- 2) Level sensor attaches to bottom of structure; on the square tube the runs full length from axle to axle.
- 3) Hydraulic hose terminations for room #1, #3, & #4 require 90 degree swivel elbows.
- 4) Reference FM-3991 for a better visual of Room 1 hydraulic connections.
- 5) Hoses marked w90 will have the 90 deg fitting shipped loose.

Item, Length	Description / Location	Qty	Color	Vendor PN	
Kit	(Items listed below)	1		8294	
Pump	8-Function, 4 Rooms & Jacks	1		7302BR	Measuring from inside of firewall, this is the end location of the hydraulic hoses where they attach to the slide mechanism.
Jack	17,000 lbs, 18" Stroke	4		7134	
Touch Pad	Located to the left of the drivers seat	1		2318	
Control Box	Attached to bottom of structure	1		2730	
Sync Cylinder	Mounted behind LP tank	1		7387	
Hose, 144	Pump to Jack, Left Front	2	Brown	2467	
Hose, 396	Pump to Jack, Left Rear	2	Orange	2483	
Hose, 144	Pump to Jack, Right Front	2	White	2467	
Hose, 396	Pump to Jack, Right Rear	2	Yellow	2483	
Hose, 144	Pump to synchronizing cylinder	2	Green	2467	
Hose w90, 168	Sync cylinder to front slide, Room 1	2	Green	2469	103 / Drivers side
Hose w90, 168	Sync cylinder to rear slide, Room 1	2	Green	2469	196 / Drivers side
	Pump to Room 1	N/A	Green		
Slide Unit	Room 1 - 36" flush floor slide	2		7164D	
Hose, 480	Pump to Room 2	2	Purple	2490	340 / Drivers Side
Slide Unit	Room 2 - 30" Bed slide (Lippert)	1		134998	
Hose w90, 432	Pump to Room 3	2	Gray	2486	365 / Passenger Side
Slide Unit	Room 3 - 18" above floor slide	1		7135	
Hose w90, 228	Pump to Room 4	2	Red	2474	155 / Passenger Side
Slide Unit	Room 4 - 18" above floor slide	1		7135	
	Pump to Generator Slide	N/A			N/A
Travel Clamp	(two per slide, except the bed slide)	6		HWH	N/A

Options

Revisions

	Beginning with release of 1/23/06 and documented on ECN #3845
1	ECN#4099 Equalizer standardize sizes & renumbers parts, 90 deg fitting ship loose
2	UPDATE JPG
3	Updated per ECN #4237

39D Presidio
EQUALIZER JACKS (FULLY AUTOMATIC)
STANDARD ON THIS UNIT

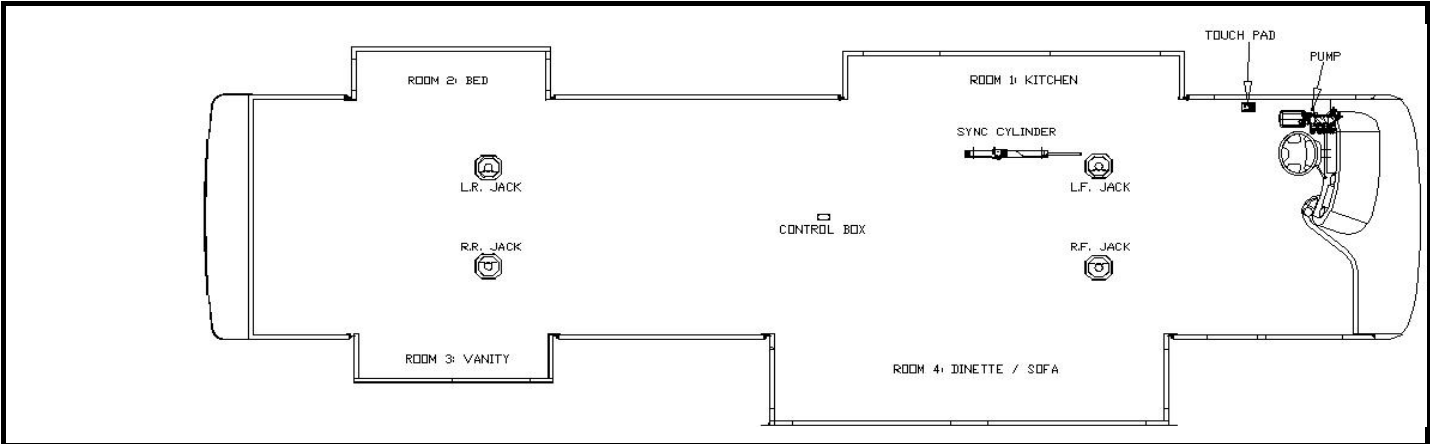

Notes:

- 1) Jacks mount to chassis brackets with the lowest holes of the jacks aligned with the lowest holes of the mounting brackets.
- 2) Level sensor attaches to bottom of structure; on the square tube the runs full length from axle to axle.
- 3) Hydraulic hose terminations for room #1, #3, & #4 require 90 degree swivel elbows.
- 4) Reference FM-3991 for a better visual of Room 4 hydraulic connections.
- 5) Hoses marked w90 will have the 90 deg fitting shipped loose.

Item, Length	Description / Location	Qty	Color	Vendor PN	
Kit	(Items listed below)	1		8292	
Pump	8-Function, 4 Rooms & Jacks	1		7302BR	Measuring from inside of firewall, this is the end location of the hydraulic hoses where they attach to the slide mechanism.
Jack	17,000 lbs, 18" Stroke	4		7134	
Touch Pad	Located to the left of the drivers seat	1		2318	
Control Box	Attached to bottom of structure	1		2730	
Sync Cylinder	Mounted behind LP tank	1		7387	
Hose, 144	Pump to Jack, Left Front	2	Brown	2467	
Hose, 396	Pump to Jack, Left Rear	2	Orange	2483	
Hose, 144	Pump to Jack, Right Front	2	White	2467	
Hose, 396	Pump to Jack, Right Rear	2	Yellow	2483	
Hose, 144	Pump to synchronizing cylinder	2	Red	2467	
Hose w90, 168	Pump to Room 1	2	Green	2469	149 / Drivers side
Slide Unit	Room 1 - 18" above floor slide	1		7135	
Hose, 480	Pump to Room 2	2	Purple	2490	325 / Drivers Side
Slide Unit	Room 2 - 30" Bed slide (Lippert)	1		134998	
Hose w90, 432	Pump to Room 3	2	Gray	2486	355 / Passenger Side
Slide Unit	Room 3 - 18" above floor slide	1		7135	
Hose w90, 168	Sync cylinder to front slide, Room 4	2	Red	2469	103 / Passenger side
Hose w90, 168	Sync cylinder to rear slide, Room 4	2	Red	2469	196 / Passenger side
Slide Unit	Room 4 - 36" flush floor slide	2		7164D	
	Pump to Generator Slide	N/A			N/A
Travel Clamp	(two per slide, except the bed slide)	6		HWH	N/A

Options

Revisions

	Beginning with release of 1/23/06 and documented on ECN #3845
1	Equalizer lengthened hose....part #2415 (was too short per S. Jung email on 4/27)
2	ECN#4099 Equalizer standardize sizes & rennumbers parts, 90 deg fitting ship loose
3	UPDATE JPG

**39E Presidio
EQUALIZER JACKS (FULLY AUTOMATIC)
STANDARD ON THIS UNIT**

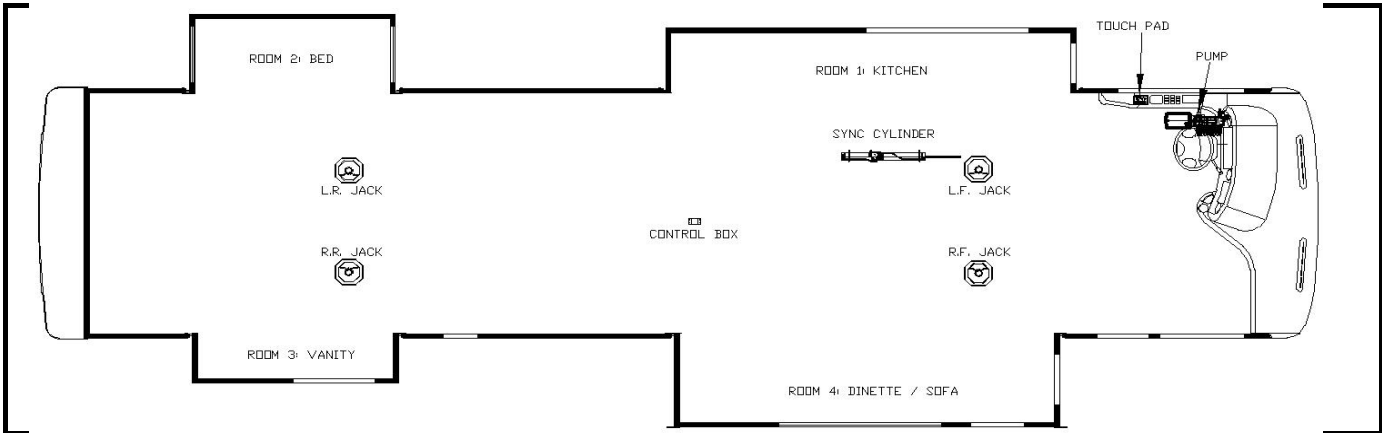

Notes:

- 1) Jacks mount to chassis brackets with the lowest holes of the jacks aligned with the lowest holes of the mounting brackets.
- 2) Level sensor attaches to bottom of structure; on the square tube the runs full length from axle to axle.
- 3) Hydraulic hose terminations for room #1, #3, & #4 require 90 degree swivel elbows.
- 4) Reference FM-3991 for a better visual of Room 4 hydraulic connections.
- 5) Hoses marked w90 will have the 90 deg fitting shipped loose.

Item, Length	Description / Location	Qty	Color	Vendor PN	
Kit	(Items listed below)	1		8315	
Pump	8-Function, 4 Rooms & Jacks	1		7302BR	Measuring from inside of firewall, this is the end location of the hydraulic hoses where they attach to the slide mechanism.
Jack	17,000 lbs, 18" Stroke	4		7134	
Touch Pad	Located to the left of the drivers seat	1		2318	
Control Box	Attached to bottom of structure	1		2730	
Sync Cylinder	Mounted behind LP tank	2		7397	
Hose, 144	Pump to Jack, Left Front	2	Brown	2467	
Hose, 396	Pump to Jack, Left Rear	2	Orange	2483	
Hose, 144	Pump to Jack, Right Front	2	White	2467	
Hose, 396	Pump to Jack, Right Rear	2	Yellow	2483	
Hose, 144	Pump to synchronizing cylinder	2	Green	2467	
Hose, 144	Pump to synchronizing cylinder	2	Red	2467	Mounts to bracket on structure
Hose, 480	Pump to Room 2	2	Purple	2490	325 / Drivers Side
Slide Unit	Room 2 - 30" Bed slide (Lippert)	1		134998	
Hose w90, 432	Pump to Room 3	2	Gray	2486	355 / Passenger Side
Slide Unit	Room 3 - 18" above floor slide	1		7135	
Hose w90, 168	Sync cylinder to front slide, Room 1	2	Green	2469	95 / Drivers Side
Hose w90, 168	Sync cylinder to rear slide, Room 1	2	Green	2469	180 / Drivers Side
Slide Unit	Room 1 - 24" flush floor slide	2		7369	
Hose w90, 168	Sync cylinder to front slide, Room 4	2	Red	2469	103 / Passenger side
Hose w90, 168	Sync cylinder to rear slide, Room 4	2	Red	2469	196 / Passenger side
Slide Unit	Room 4 - 24" flush floor slide	2		7369	
	Pump to Generator Slide	N/A			N/A
Travel Clamp	(two per slide, except the bed slide)	6		HWH	N/A

Options

Revisions

1	ECN#4099 Equalizer standardize sizes & rennumbers parts, 90 deg fitting ship loose
2	UPDATE JPG
3	Updated per ECN #4237
3	Added equalizer slide units to chart ECN# 4438

**39F Presidio
EQUALIZER JACKS (FULLY AUTOMATIC)
STANDARD ON THIS UNIT**

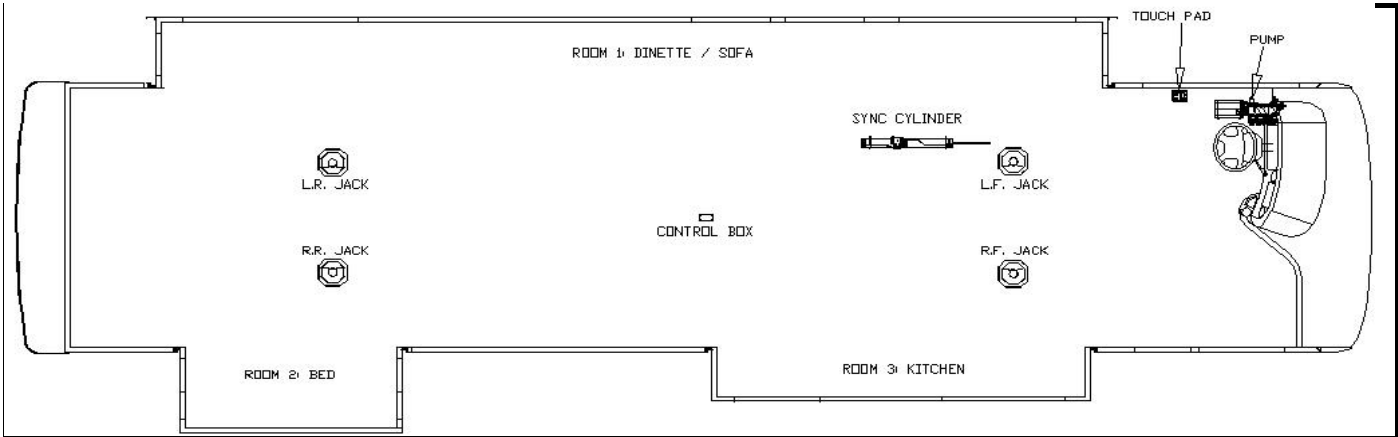

Notes:

- 1) Jacks mount to chassis brackets with the lowest holes of the jacks aligned with the lowest holes of the mounting brackets.
- 2) Level sensor attaches to bottom of structure; on the square tube the runs full length from axle to axle.
- 3) Hydraulic hose terminations for room #1 & #2 require 90 degree swivel elbows.
- 4) Room #1 will have a non-powered slide mechanism in center of room
- 5) Hoses marked w90 will have the 90 deg fitting shipped loose.

Item, Length	Description / Location	Qty	Color	Vendor PN		
Kit	(Items listed below)	1		8340	Measuring from inside of firewall, this is the end location of the hydraulic hoses where they attach to the slide mechanism. Mounts to bracket on structure	
Pump	7-Function, 4 Rooms & Jacks	1		7319BR		
Jack	17,000 lbs, 18" Stroke	4		7134		
Touch Pad	Located to the left of the drivers seat	1		2318		
Control Box	Attached to bottom of structure	1		2730		
Sync Cylinder	Mounted behind LP tank	1		7397		
Hose, 144	Pump to Jack, Left Front	2	Brown	2467		
Hose, 396	Pump to Jack, Left Rear	2	Orange	2483		
Hose, 144	Pump to Jack, Right Front	2	White	2467		
Hose, 420	Pump to Jack, Right Rear	2	Yellow	2485		
Hose, 144	Pump to synchronizing cylinder	2	Green	2467		
Hose w90, 432	Sync cylinder to front slide, Room 1	2	Green	2486		103 / Drivers side
Hose w90, 432	Sync cylinder to rear slide, Room 1	2	Green	2486		350 / Drivers side
Slide Unit	Room 1 - 24" flush floor slide (angled)	2		7388		
Slide Unit	Room 1 - 24" flush floor slide (angled)	1		7384		Slave
Hose, 480	Pump to Room 2	2	Purple	2490		345 / Drivers Side
Slide Unit	Room 2 - 30" Bed slide (Lippert)	1		134998		
Hose w90, 228	Pump to Room 3	2	Gray	2474	146 / Passenger Side	
Slide Unit	Room 3 - 18" above floor slide	1		7135		
	Pump to Generator Slide	N/A			N/A	
Travel Clamp	(two per slide, except the bed slide)	4		HWH	N/A	
Options						

Revisions	
1	UPDATE JPG
2	Updated per ECN #4237
3	Added equalizer slide units to chart ECN# 4438
4	Corrected bed slide Vendor Part No. Was 143960 JS 8-15-07

**39G Presidio
EQUALIZER JACKS (FULLY AUTOMATIC)
STANDARD ON THIS UNIT**

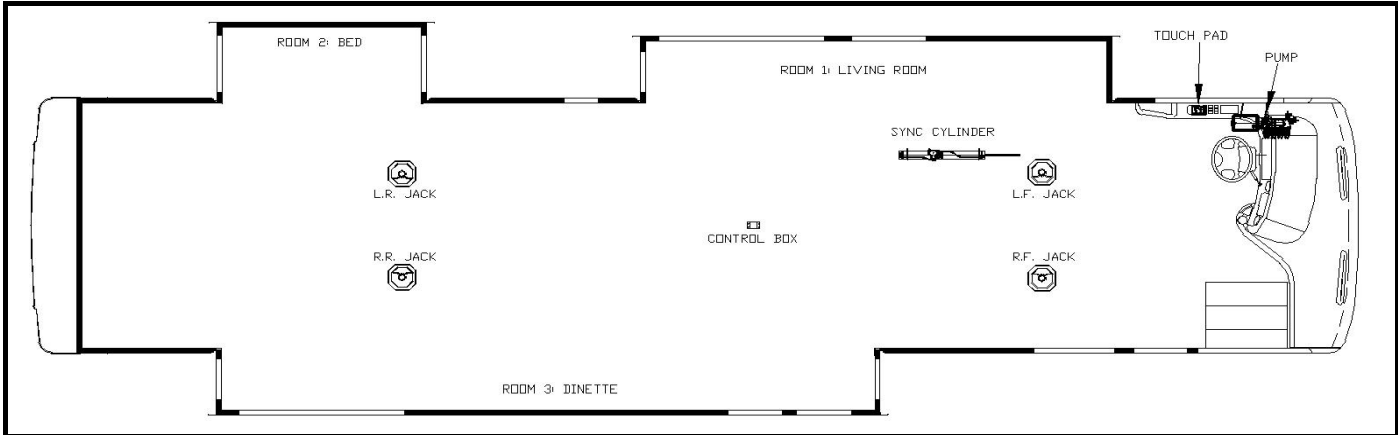

Notes:

- 1) Jacks mount to chassis brackets with the lowest holes of the jacks aligned with the lowest holes of the mounting brackets.
- 2) Level sensor attaches to bottom of structure; on the square tube the runs full length from axle to axle.
- 3) Hydraulic hose terminations for room #1 & #2 require 90 degree swivel elbows.
- 4) Room #1 will have a non-powered slide mechanism in center of room
- 5) Hoses marked w90 will have the 90 deg fitting shipped loose.

Item, Length	Description / Location	Qty	Color	Vendor PN	
Kit	(Items listed below)	1		8354	
Pump	7-Function, 3 Rooms & Jacks	1		7319BR	Measuring from inside of firewall, this is the end location of the hydraulic hoses where they attach to the slide mechanism.
Jack	17,000 lbs, 18" Stroke	4		7134	
Touch Pad	Located to the left of the drivers seat	1		2318	
Control Box	Attached to bottom of structure	1		2730	
Sync Cylinder	Mounted behind LP tank	2		7397	
Hose, 144	Pump to Jack, Left Front	2	Brown	2467	
Hose, 408	Pump to Jack, Left Rear	2	Orange	2484	
Hose, 144	Pump to Jack, Right Front	2	White	2467	
Hose, 408	Pump to Jack, Right Rear	2	Yellow	2484	
Hose, 144	Pump to synchronizing cylinder	2	Green	2467	
Hose w90, 168	Sync cylinder to front slide, Room 1	2	Green	2469	Mounts to bracket on structure 103 / Drivers side
Hose w90, 168	Sync cylinder to rear slide, Room 1	2	Green	2469	205 / Drivers side
Slide Unit	Room 1 - 24" flush floor slide (angled)	2		7388	
Hose w90, 360	Sync cylinder to front slide, Room 3	2	Gray	2527	205 / Passenger side
Hose w90, 360	Sync cylinder to rear slide, Room 3	2	Gray	2527	350 / Passenger side
Slide Unit	Room 3 - 24" flush floor slide (angled)	2		7388	
Hose, 480	Pump to Room 2	2	Purple	2490	345 / Drivers Side
Slide Unit	Room 2 - 30" Bed slide (Lippert)	1		134998	
	Pump to Generator Slide	N/A			N/A
Travel Clamp	(two per slide, except the bed slide)	4		HWH	N/A
Hose, 144	Pump to synchronizing cylinder	2	Gray	2467	Mounts to bracket on structure
Options					

Revisions

1	Corrected picture			
2	Corrected hose notes for room #3 & #1.....3-5-07			
3	Added equalizer slide units to chart ECN# 4438			
4	Corrected bed slide Vendor Part No. Was 143960		JS 8-15-07	

**42A Presidio
EQUALIZER JACKS (FULLY AUTOMATIC)
STANDARD ON THIS UNIT**

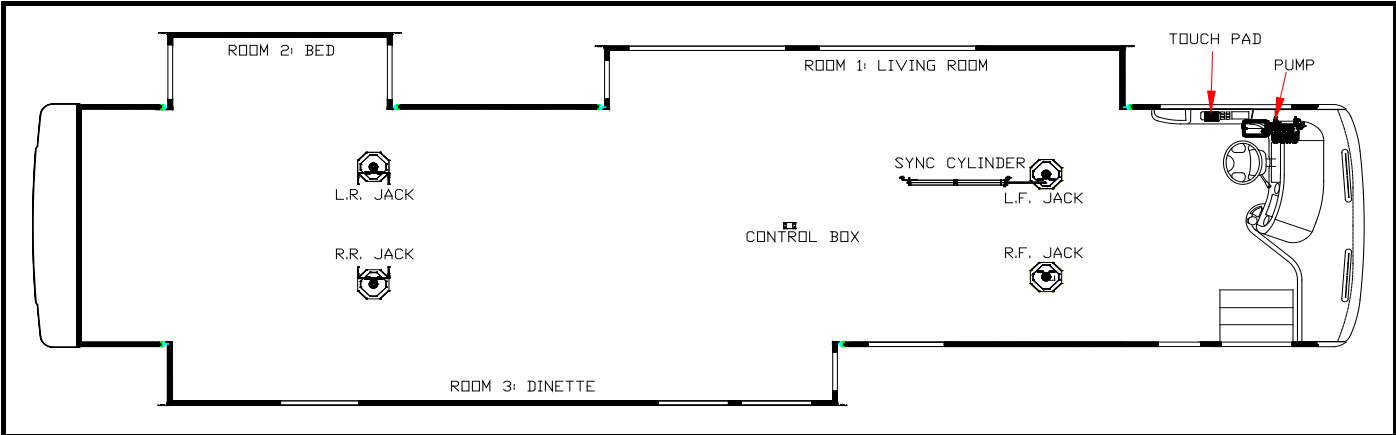

Notes:

- 1) Jacks mount to chassis brackets with the lowest holes of the jacks aligned with the lowest holes of the mounting brackets.
- 2) Level sensor attaches to bottom of structure; on the square tube the runs full length from axle to axle.
- 3) Hydraulic hose terminations for room #1 & #3 require 90 degree swivel elbows.
- 4) Hoses marked w90 will have the 90 deg fitting shipped loose.

Item, Length	Description / Location	Qty	Color	Vendor PN	
Kit	(Items listed below)	1		8373	
Pump	7-Function, 3 Rooms & Jacks	1		7319BR	Measuring from inside of firewall, this is the end location of the hydraulic hoses where they attach to the slide mechanism.
Jack	17,000 lbs, 18" Stroke	4		7134	
Touch Pad	Located to the left of the drivers seat	1		2318	
Control Box	Attached to bottom of structure	1		2730	
Sync Cylinder	Mounted behind LP tank	2		7397	
Hose, 144	Pump to Jack, Left Front	2	Brown	2467	
Hose, 408	Pump to Jack, Left Rear	2	Orange	2484	
Hose, 144	Pump to Jack, Right Front	2	White	2467	
Hose, 408	Pump to Jack, Right Rear	2	Yellow	2484	
Hose, 168	Pump to synchronizing cylinder	2	Green	2469	
Hose w90, 168	Sync cylinder to front slide, Room 1	2	Green	2469	Mounts to bracket on structure 130 / Drivers side
Hose w90, 168	Sync cylinder to rear slide, Room 1	2	Green	2469	220 / Drivers side
Slide Unit	Room 1 - 24" flush floor slide (angled)	2		7388	
Hose w90, 360	Sync cylinder to front slide, Room 3	2	Gray	2527	235 / Passenger side
Hose w90, 360	Sync cylinder to rear slide, Room 3	2	Gray	2527	385 / Passenger side
Slide Unit	Room 3 - 24" flush floor slide (angled)	2		7388	
Hose, 516	Pump to Room 2	2	Purple	2491	420 / Drivers Side
Slide Unit	Room 2 - 30" Bed slide (Lippert)	1		134998	
	Pump to Generator Slide	N/A			N/A
Travel Clamp	(two per slide, except the bed slide)	4		HWH	N/A
Hose, 168	Pump to synchronizing cylinder	2	Gray	2469	Mounts to bracket on structure

Options

Revisions

1	Updated before intial quote.	JES 8-9-07
2	Corrected bed slide Vendor Part No. Was 143960	JS 8-15-07

**42B Presidio
EQUALIZER JACKS (FULLY AUTOMATIC)
STANDARD ON THIS UNIT**

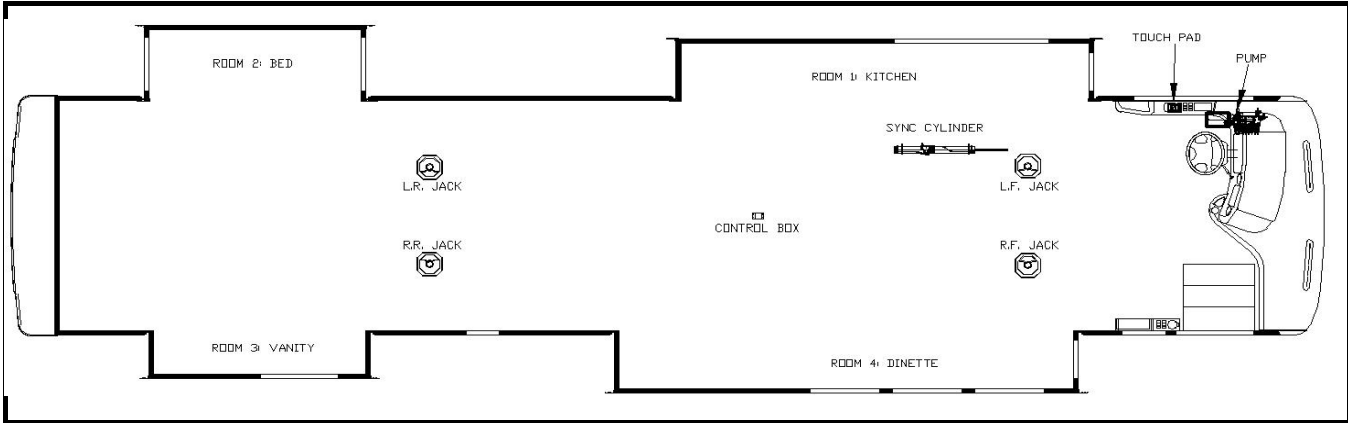

- Notes:**
- 1) Jacks mount to chassis brackets with the lowest holes of the jacks aligned with the lowest holes of the mounting brackets.
 - 2) Level sensor attaches to bottom of structure; on the square tube the runs full length from axle to axle.
 - 3) Hydraulic hose terminations for room #1 & #3 require 90 degree swivel elbows.
 - 4) Hoses marked w90 will have the 90 deg fitting shipped loose.

Item, Length	Description / Location	Qty	Color	Vendor PN	
Kit	(Items listed below)	1		8379	Measuring from inside of firewall, this is the end location of the hydraulic hoses where they attach to the slide mechanism.
Pump	8-Function, 4 Rooms & Jacks	1		7302BR	
Jack	17,000 lbs, 18" Stroke	4		7134	
Touch Pad	Located to the left of the drivers seat	1		2318	
Control Box	Attached to bottom of structure	1		2730	
Sync Cylinder	Mounted behind LP tank	2		7397	
Hose, 144	Pump to Jack, Left Front	2	Brown	2467	
Hose, 408	Pump to Jack, Left Rear	2	Orange	2484	
Hose, 144	Pump to Jack, Right Front	2	White	2467	
Hose, 408	Pump to Jack, Right Rear	2	Yellow	2484	
Hose, 168	Pump to synchronizing cylinder	2	Green	2469	Mounts to bracket on structure
Hose, 168	Pump to synchronizing cylinder	2	Red	2469	Mounts to bracket on structure
Hose w90, 168	Sync cylinder to front slide, Room 1	2	Green	2469	115 / Drivers side
Hose w90, 168	Sync cylinder to rear slide, Room 1	2	Green	2469	205 / Drivers side
Slide Unit	Room 1 - 24" flush floor slide (angled)	2		7388	
Hose, 516	Pump to Room 2	2	Purple	2491	420 / Drivers Side
Slide Unit	Room 2 - 30" Bed slide (Lippert)	1		134998	
Hose w90, 516	Pump to Room 3	2	Gray	2491	404 / Passenger side
Slide Unit	Room 3 - 18" above floor slide	1		7135	
Hose w90, 288	Sync cylinder to front slide, Room 4	2	Red	2478	115 / Passenger side
Hose w90, 288	Sync cylinder to rear slide, Room 4	2	Red	2478	254 / Passenger side
Slide Unit	Room 4 - 24" flush floor slide (angled)	2		7388	
	Pump to Generator Slide	N/A			N/A
Travel Clamp	(two per slide, except the bed slide)	6		HWH	N/A

Options

Revisions

**36B Presidio
EQUALIZER JACKS (FULLY AUTOMATIC)
STANDARD ON THIS UNIT**

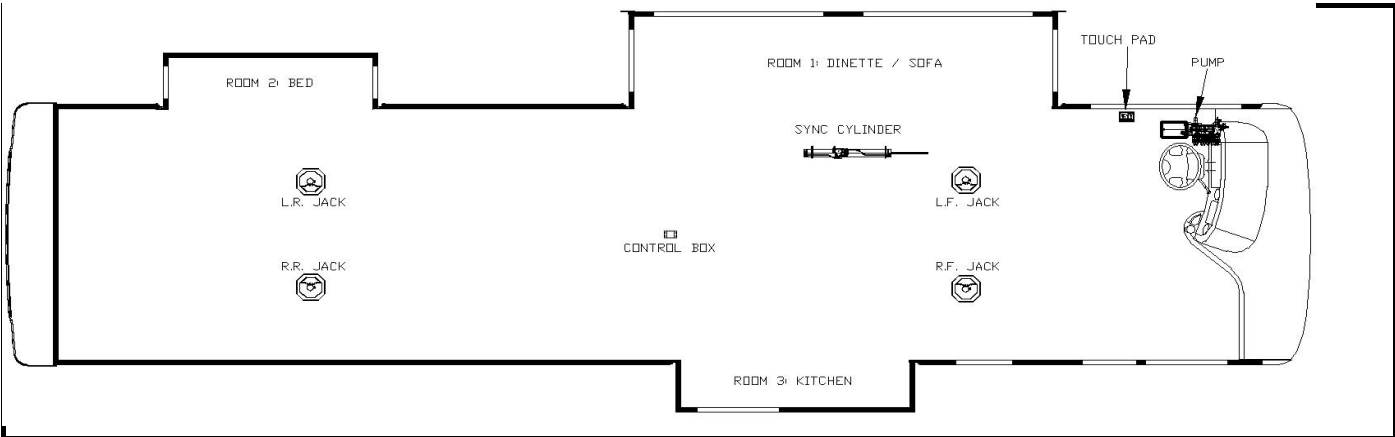

Notes:

- 1) Jacks mount to chassis brackets with the lowest holes of the jacks aligned with the lowest holes of the mounting brackets.
- 2) Level sensor attaches to bottom of structure; on lower hat section flanges or square tube.
- 3) Hydraulic hose terminations for room #1 & #3 require 90 degree swivel elbows.
- 4) Reference FM-3991 for a better visual of Room 1 hydraulic connections.
- 5) Hoses marked w90 will have the 90 deg fitting shipped loose.

Item, Length	Description / Location	Qty	Color	Vendor PN		
Kit	(Items listed below)	1		8310		
Pump	7-Function, 3 Rooms & Jacks	1		7319BR		
Jack	17,000 lbs, 18" Stroke	4		7134		
Touch Pad	Located to the left of the drivers seat	1		2318	<p align="center">Measuring from inside of firewall, this is the end location of the hydraulic hoses where they attach to the slide mechanism.</p>	
Control Box	Attached to bottom of structure	1		2730		
Sync Cylinder	Mounted behind LP tank	1		7387		
Hose, 132	Pump to Jack, Left Front	2	Brown	2466		
Hose, 372	Pump to Jack, Left Rear	2	Orange	2481		
Hose, 144	Pump to Jack, Right Front	2	White	2467		
Hose, 372	Pump to Jack, Right Rear	2	Yellow	2481		
Hose, 144	Pump to synchronizing manifold	2	Green	2467		
Hose w90, 168	Sync cylinder to front slide, Room 1	2	Green	2469		Mounts to bracket on structure
Hose w90, 168	Sync cylinder to rear slide, Room 1	2	Green	2469		103 / Drivers side
	Pump to Room 1	N/A	Green		196 / Drivers side	
Slide Unit	Room 1 - 36" flush floor slide	2		7164D		
Hose, 420	Pump to Room 2	2	Purple	2485	325 / Drivers Side	
Slide Unit	Room 2 - 30" Bed slide (Lippert)	1		134998		
Hose w90, 204	Pump to Room 3	2	Red	2472	146 / Passenger Side	
Slide Unit	Room 3 - 18" above floor slide	1		7135		
	Pump to Generator Slide	N/A			N/A	
Travel Clamp	(two per slide, except the bed slide)	4		HWH	N/A	
Options						
Revisions						
1	Added equalizer slide units to chart ECN# 4438					
2	Corrected bed slide Vendor Part No. Was 143960		JS 8-15-07			

**38C Presidio
EQUALIZER JACKS (FULLY AUTOMATIC)
STANDARD ON THIS UNIT**

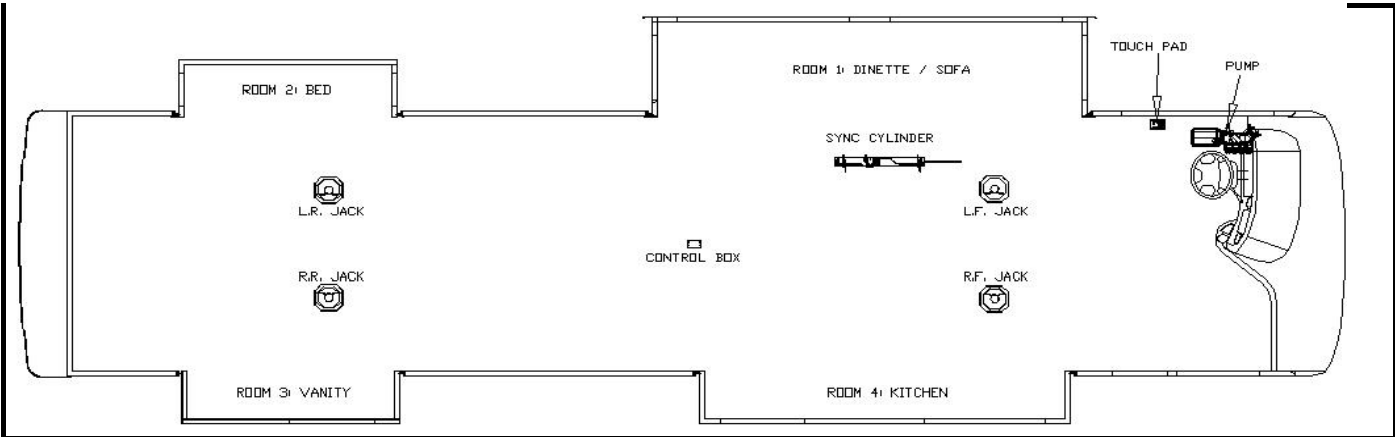

Notes:

- 1) Jacks mount to chassis brackets with the lowest holes of the jacks aligned with the lowest holes of the mounting brackets.
- 2) Level sensor attaches to bottom of structure; on lower hat section flanges or square tube.
- 3) Hydraulic hose terminations for room #1, #3, & #4 require 90 degree swivel elbows.
- 4) Reference FM-3991 for a better visual of Room 1 hydraulic connections.
- 5) Hoses marked w90 will have the 90 deg fitting shipped loose.

Item, Length	Description / Location	Qty	Color	Vendor PN		
Kit	(Items listed below)	1		8278	Measuring from inside of firewall, this is the end location of the hydraulic hoses where they attach to the slide mechanism.	
Pump	8-Function, 4 Rooms & Jacks	1		7302BR		
Jack	17,000 lbs, 18" Stroke	4		7134		
Touch Pad	Located to the left of the drivers seat	1		2318		
Control Box	Attached to bottom of structure	1		2730		
Sync Cylinder	Mounted behind LP tank	1		7387		
Hose, 132	Pump to Jack, Left Front	2	Brown	2466		
Hose, 372	Pump to Jack, Left Rear	2	Orange	2481		
Hose, 144	Pump to Jack, Right Front	2	White	2467		
Hose, 372	Pump to Jack, Right Rear	2	Yellow	2481		
Hose, 144	Pump to synchronizing manifold	2	Green	2467		Mounts to bracket on structure
Hose w90, 168	Sync cylinder to front slide, Room 1	2	Green	2469		103 / Drivers side
Hose w90, 168	Sync cylinder to rear slide, Room 1	2	Green	2469		196 / Drivers side
	Pump to Room 1	N/A	Green			
Slide Unit	Room 1 - 36" flush floor slide	2		7164D		
Hose, 420	Pump to Room 2	2	Purple	2485		325 / Drivers Side
Slide Unit	Room 2 - 30" Bed slide (Lippert)	1		134998		
Hose w90, 456	Pump to Room 3	2	Gray	2488	355 / Passenger Side	
Slide Unit	Room 3 - 18" above floor slide	1		7135		
Hose w90, 204	Pump to Room 4	2	Red	2472	146 / Passenger Side	
Slide Unit	Room 4 - 18" above floor slide	1		7135		
	Pump to Generator Slide	N/A			N/A	
Travel Clamp	(two per slide, except the bed slide)	6		HWH	N/A	
Options						
Revisions						
1	Added equalizer slide units to chart ECN# 4438					
2	Corrected bed slide Vendor Part No. Was 143960		JS 8-15-07			

**38D Presidio
EQUALIZER JACKS (FULLY AUTOMATIC)
STANDARD ON THIS UNIT**

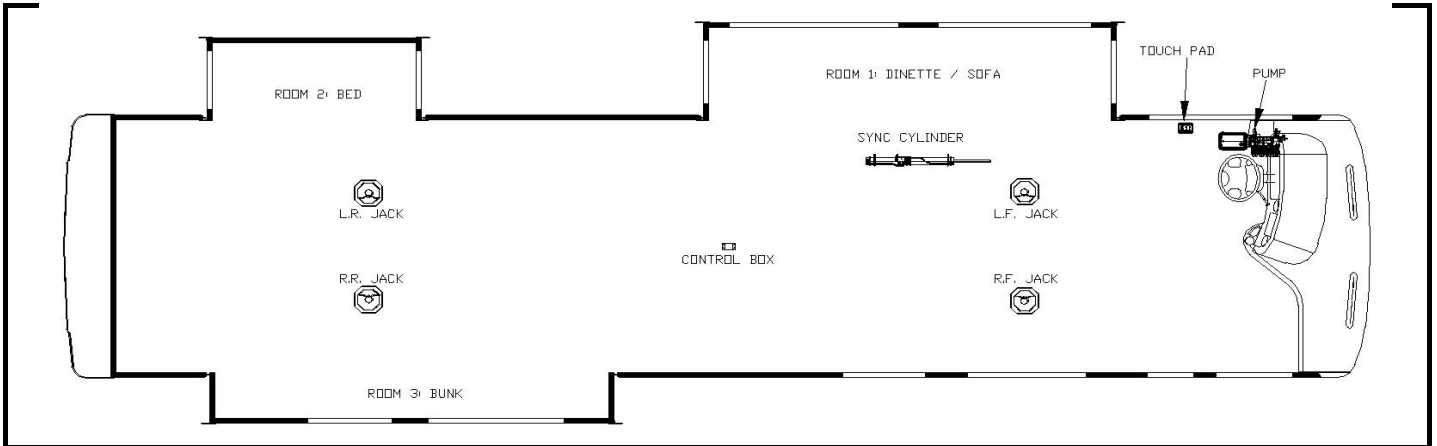

Notes:

- 1) Jacks mount to chassis brackets with the lowest holes of the jacks aligned with the lowest holes of the mounting brackets.
- 2) Level sensor attaches to bottom of structure; on lower hat section flanges or square tube.
- 3) Hydraulic hose terminations for room #1 & #3 require 90 degree swivel elbows.
- 4) Reference FM-3991 for a better visual of Room 1 hydraulic connections.
- 5) Hoses marked w90 will have the 90 deg fitting shipped loose.

Item, Length	Description / Location	Qty	Color	Vendor PN	
Kit	(Items listed below)	1		8347	
Pump	7-Function, 3 Rooms & Jacks	1		7319BR	Measuring from inside of firewall, this is the end location of the hydraulic hoses where they attach to the slide mechanism.
Jack	17,000 lbs, 18" Stroke	4		7134	
Touch Pad	Located to the left of the drivers seat	1		2318	
Control Box	Attached to bottom of structure	1		2730	
Sync Cylinder	Mounted behind LP tank	1		7387	
Hose, 132	Pump to Jack, Left Front	2	Brown	2466	
Hose, 372	Pump to Jack, Left Rear	2	Orange	2481	
Hose, 144	Pump to Jack, Right Front	2	White	2467	
Hose, 384	Pump to Jack, Right Rear	2	Yellow	2482	
Hose, 144	Pump to synchronizing manifold	2	Green	2467	
Hose w90, 168	Sync cylinder to front slide, Room 1	2	Green	2469	Mounts to bracket on structure 103 / Drivers side
Hose w90, 168	Sync cylinder to rear slide, Room 1	2	Green	2469	196 / Drivers side
	Pump to Room 1	N/A	Green		
Slide Unit	Room 1 - 36" flush floor slide	2		7164D	
Hose, 432	Pump to Room 2	2	Purple	2486	325 / Drivers Side
Slide Unit	Room 2 - 30" Bed slide (Lippert)	1		134998	
Hose w90, 456	Pump to Room 3	2	Gray	2488	355 / Passenger Side
Slide Unit	Room 3 - 18" above floor slide	1		7135	
	Pump to Generator Slide	N/A			
Travel Clamp	(two per slide, dinette / sofa slide only)	2		HWH	N/A

Options

Revisions

1	Added equalizer slide units to chart ECN# 4438			
2	Corrected bed slide Vendor Part No. Was 143960		JS 8-15-07	

**38E Presidio
EQUALIZER JACKS (FULLY AUTOMATIC)
STANDARD ON THIS UNIT**

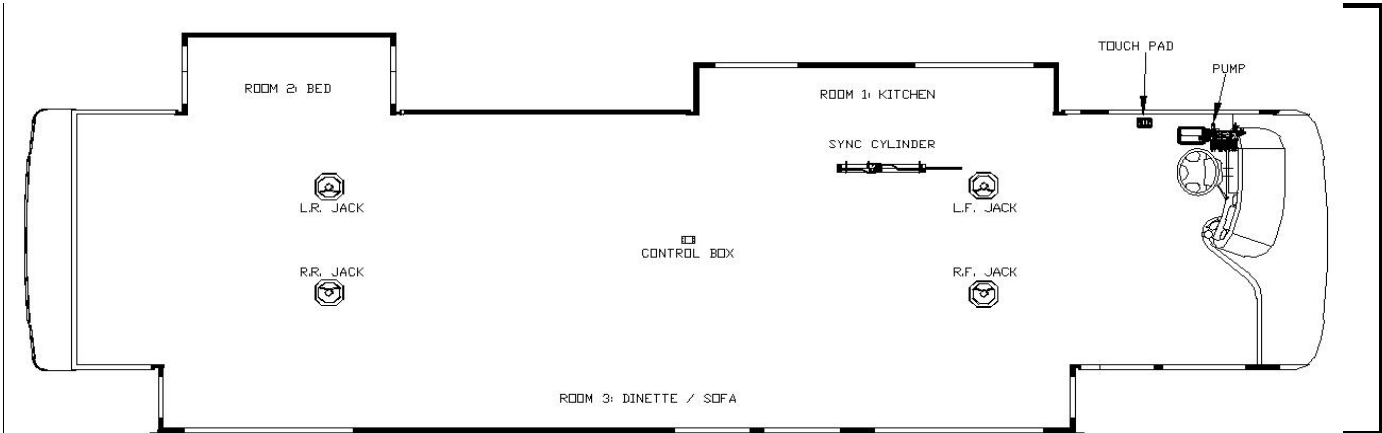

- 1) Jacks mount to chassis brackets with the lowest holes of the jacks aligned with the lowest holes of the mounting brackets.
- 2) Level sensor attaches to bottom of structure; on the square tube the runs full length from axle to axle.
- 3) Hydraulic hose terminations for room #2 & #3 require 90 degree swivel elbows.
- 4) Room #3 will have a non-powered slide mechanism in center of room
- 5) Hoses marked w90 will have the 90 deg fitting shipped loose.

Item, Length	Description / Location	Qty	Color	Vendor PN	
Kit	(Items listed below)	1		8350	
Pump	7-Function, 4 Rooms & Jacks	1		7319BR	Measuring from inside of firewall, this is the end location of the hydraulic hoses where they attach to the slide mechanism.
Jack	17,000 lbs, 18" Stroke	4		7134	
Touch Pad	Located to the left of the drivers seat	1		2318	
Control Box	Attached to bottom of structure	1		2730	
Sync Cylinder	Mounted behind LP tank	1		7397	
Hose, 144	Pump to Jack, Left Front	2	Brown	2467	
Hose, 396	Pump to Jack, Left Rear	2	Orange	2483	
Hose, 144	Pump to Jack, Right Front	2	White	2467	
Hose, 396	Pump to Jack, Right Rear	2	Yellow	2483	
Hose, 144	Pump to synchronizing cylinder	2	Gray	2467	
Hose w90, 432	Sync cylinder to front slide, Room 3	2	Gray	2486	103 / Drivers side
Hose w90, 432	Sync cylinder to rear slide, Room 3	2	Gray	2486	350 / Drivers side
Slide Unit	Room 3 - 24" flush floor slide (angled)	2		7388	
Slide Unit	Room 3 - 24" flush floor slide (angled)	1		7384	Slave
	Pump to Room 1	N/A	Green		
Hose w90, 180	Pump to Room 1	2	Green	2470	146 / Passenger Side
Slide Unit	Room 1 - 18" above floor slide	1		7135	
Hose, 480	Pump to Room 2	2	Purple	2490	345 / Drivers Side
Slide Unit	Room 2 - 30" Bed slide (Lippert)	1		134998	
	Pump to Generator Slide	N/A			N/A
Travel Clamp	(two per slide, except the bed slide)	4		HWH	N/A
Options					

Revisions					
1	Added equalizer slide units to chart ECN# 4438				
2	Corrected bed slide Vendor Part No. Was 143960		JS 8-15-07		

**39B Presidio
EQUALIZER JACKS (FULLY AUTOMATIC)
STANDARD ON THIS UNIT**

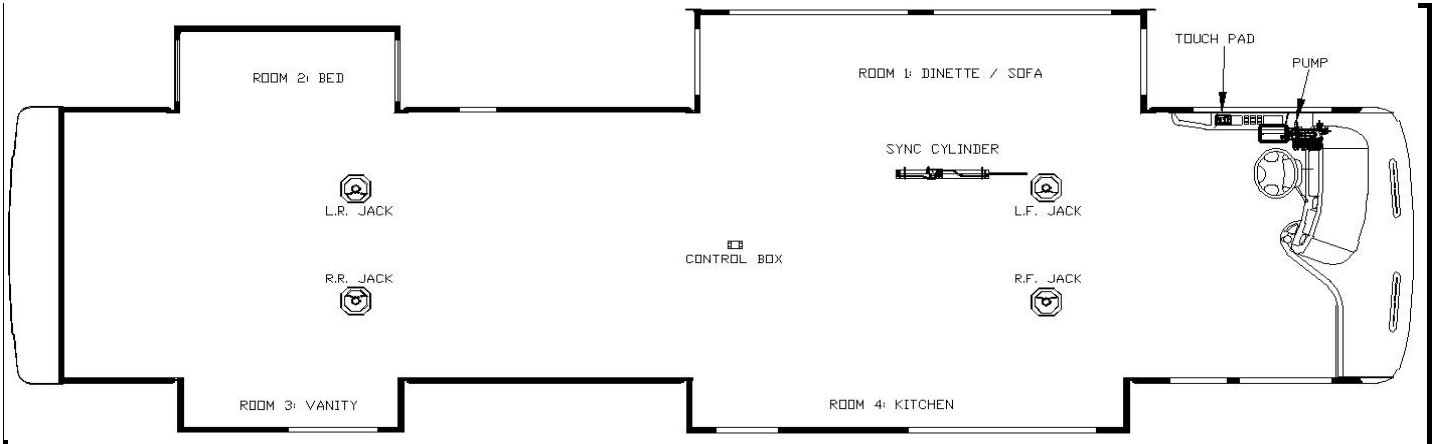

Notes:

- 1) Jacks mount to chassis brackets with the lowest holes of the jacks aligned with the lowest holes of the mounting brackets.
- 2) Level sensor attaches to bottom of structure; on the square tube the runs full length from axle to axle.
- 3) Hydraulic hose terminations for room #1, #3, & #4 require 90 degree swivel elbows.
- 4) Reference FM-3991 for a better visual of Room 1 hydraulic connections.
- 5) Hoses marked w90 will have the 90 deg fitting shipped loose.

Item, Length	Description / Location	Qty	Color	Vendor PN	
Kit	(Items listed below)	1		8294	
Pump	8-Function, 4 Rooms & Jacks	1		7302BR	Measuring from inside of firewall, this is the end location of the hydraulic hoses where they attach to the slide mechanism.
Jack	17,000 lbs, 18" Stroke	4		7134	
Touch Pad	Located to the left of the drivers seat	1		2318	
Control Box	Attached to bottom of structure	1		2730	
Sync Cylinder	Mounted behind LP tank	1		7387	
Hose, 144	Pump to Jack, Left Front	2	Brown	2467	
Hose, 396	Pump to Jack, Left Rear	2	Orange	2483	
Hose, 144	Pump to Jack, Right Front	2	White	2467	
Hose, 396	Pump to Jack, Right Rear	2	Yellow	2483	
Hose, 144	Pump to synchronizing cylinder	2	Green	2467	
Hose w90, 168	Sync cylinder to front slide, Room 1	2	Green	2469	Mounts to bracket on structure 103 / Drivers side
Hose w90, 168	Sync cylinder to rear slide, Room 1	2	Green	2469	196 / Drivers side
	Pump to Room 1	N/A	Green		
Slide Unit	Room 1 - 36" flush floor slide	2		7164D	
Hose, 480	Pump to Room 2	2	Purple	2490	340 / Drivers Side
Slide Unit	Room 2 - 30" Bed slide (Lippert)	1		134998	
Hose w90, 432	Pump to Room 3	2	Gray	2486	365 / Passenger Side
Slide Unit	Room 3 - 18" above floor slide	1		7135	
Hose w90, 228	Pump to Room 4	2	Red	2474	155 / Passenger Side
Slide Unit	Room 4 - 18" above floor slide	1		7135	
	Pump to Generator Slide	N/A			N/A
Travel Clamp	(two per slide, except the bed slide)	6		HWH	N/A

Options

Revisions

	Beginning with release of 1/23/06 and documented on ECN #3845
1	ECN#4099 Equalizer standardize sizes & renumbers parts, 90 deg fitting ship loose
2	UPDATE JPG
3	Updated per ECN #4237

**39D Presidio
EQUALIZER JACKS (FULLY AUTOMATIC)
STANDARD ON THIS UNIT**

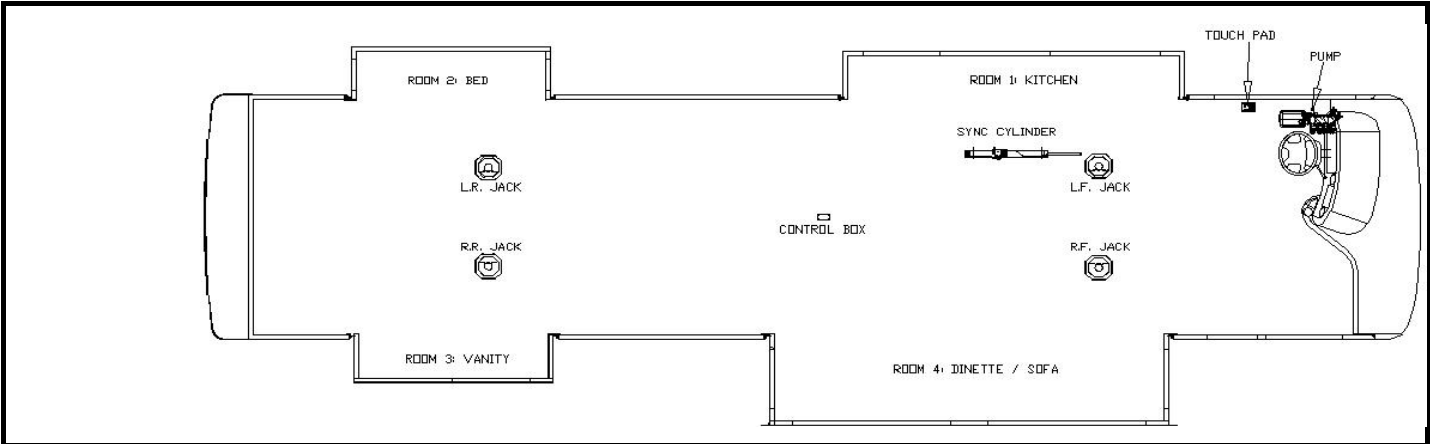

Notes:

- 1) Jacks mount to chassis brackets with the lowest holes of the jacks aligned with the lowest holes of the mounting brackets.
- 2) Level sensor attaches to bottom of structure; on the square tube the runs full length from axle to axle.
- 3) Hydraulic hose terminations for room #1, #3, & #4 require 90 degree swivel elbows.
- 4) Reference FM-3991 for a better visual of Room 4 hydraulic connections.
- 5) Hoses marked w90 will have the 90 deg fitting shipped loose.

Item, Length	Description / Location	Qty	Color	Vendor PN	
Kit	(Items listed below)	1		8292	
Pump	8-Function, 4 Rooms & Jacks	1		7302BR	Measuring from inside of firewall, this is the end location of the hydraulic hoses where they attach to the slide mechanism.
Jack	17,000 lbs, 18" Stroke	4		7134	
Touch Pad	Located to the left of the drivers seat	1		2318	
Control Box	Attached to bottom of structure	1		2730	
Sync Cylinder	Mounted behind LP tank	1		7387	
Hose, 144	Pump to Jack, Left Front	2	Brown	2467	
Hose, 396	Pump to Jack, Left Rear	2	Orange	2483	
Hose, 144	Pump to Jack, Right Front	2	White	2467	
Hose, 396	Pump to Jack, Right Rear	2	Yellow	2483	
Hose, 144	Pump to synchronizing cylinder	2	Red	2467	
Hose w90, 168	Pump to Room 1	2	Green	2469	149 / Drivers side
Slide Unit	Room 1 - 18" above floor slide	1		7135	
Hose, 480	Pump to Room 2	2	Purple	2490	325 / Drivers Side
Slide Unit	Room 2 - 30" Bed slide (Lippert)	1		134998	
Hose w90, 432	Pump to Room 3	2	Gray	2486	355 / Passenger Side
Slide Unit	Room 3 - 18" above floor slide	1		7135	
Hose w90, 168	Sync cylinder to front slide, Room 4	2	Red	2469	103 / Passenger side
Hose w90, 168	Sync cylinder to rear slide, Room 4	2	Red	2469	196 / Passenger side
Slide Unit	Room 4 - 36" flush floor slide	2		7164D	
	Pump to Generator Slide	N/A			N/A
Travel Clamp	(two per slide, except the bed slide)	6		HWH	N/A

Options

Revisions

	Beginning with release of 1/23/06 and documented on ECN #3845
1	Equalizer lengthened hose....part #2415 (was too short per S. Jung email on 4/27)
2	ECN#4099 Equalizer standardize sizes & rennumbers parts, 90 deg fitting ship loose
3	UPDATE JPG

**39E Presidio
EQUALIZER JACKS (FULLY AUTOMATIC)
STANDARD ON THIS UNIT**

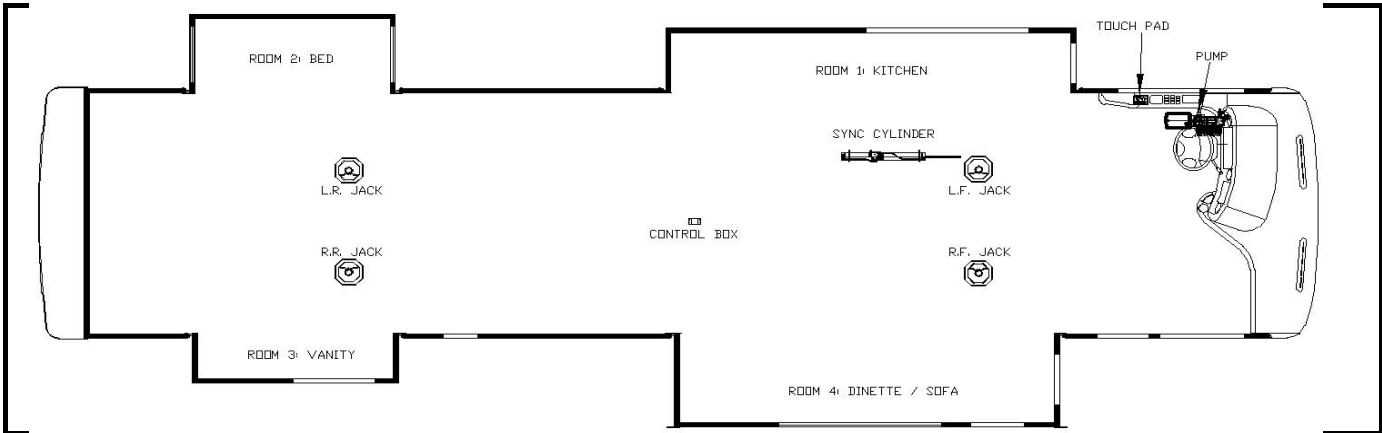

Notes:

- 1) Jacks mount to chassis brackets with the lowest holes of the jacks aligned with the lowest holes of the mounting brackets.
- 2) Level sensor attaches to bottom of structure; on the square tube the runs full length from axle to axle.
- 3) Hydraulic hose terminations for room #1, #3, & #4 require 90 degree swivel elbows.
- 4) Reference FM-3991 for a better visual of Room 4 hydraulic connections.
- 5) Hoses marked w90 will have the 90 deg fitting shipped loose.

Item, Length	Description / Location	Qty	Color	Vendor PN	
Kit	(Items listed below)	1		8315	
Pump	8-Function, 4 Rooms & Jacks	1		7302BR	Measuring from inside of firewall, this is the end location of the hydraulic hoses where they attach to the slide mechanism.
Jack	17,000 lbs, 18" Stroke	4		7134	
Touch Pad	Located to the left of the drivers seat	1		2318	
Control Box	Attached to bottom of structure	1		2730	
Sync Cylinder	Mounted behind LP tank	2		7397	
Hose, 144	Pump to Jack, Left Front	2	Brown	2467	
Hose, 396	Pump to Jack, Left Rear	2	Orange	2483	
Hose, 144	Pump to Jack, Right Front	2	White	2467	
Hose, 396	Pump to Jack, Right Rear	2	Yellow	2483	
Hose, 144	Pump to synchronizing cylinder	2	Green	2467	
Hose, 144	Pump to synchronizing cylinder	2	Red	2467	Mounts to bracket on structure
Hose, 480	Pump to Room 2	2	Purple	2490	325 / Drivers Side
Slide Unit	Room 2 - 30" Bed slide (Lippert)	1		134998	
Hose w90, 432	Pump to Room 3	2	Gray	2486	355 / Passenger Side
Slide Unit	Room 3 - 18" above floor slide	1		7135	
Hose w90, 168	Sync cylinder to front slide, Room 1	2	Green	2469	95 / Drivers Side
Hose w90, 168	Sync cylinder to rear slide, Room 1	2	Green	2469	180 / Drivers Side
Slide Unit	Room 1 - 24" flush floor slide	2		7388	
Hose w90, 168	Sync cylinder to front slide, Room 4	2	Red	2469	103 / Passenger side
Hose w90, 168	Sync cylinder to rear slide, Room 4	2	Red	2469	196 / Passenger side
Slide Unit	Room 4 - 24" flush floor slide	2		7388	
	Pump to Generator Slide	N/A			N/A
Travel Clamp	(two per slide, except the bed slide)	6		HWH	N/A

Options

Revisions

1	ECN#4099 Equalizer standardize sizes & rennumbers parts, 90 deg fitting ship loose
2	UPDATE JPG
3	Updated per ECN #4237
3	Added equalizer slide units to chart ECN# 4438

**39F Presidio
EQUALIZER JACKS (FULLY AUTOMATIC)
STANDARD ON THIS UNIT**

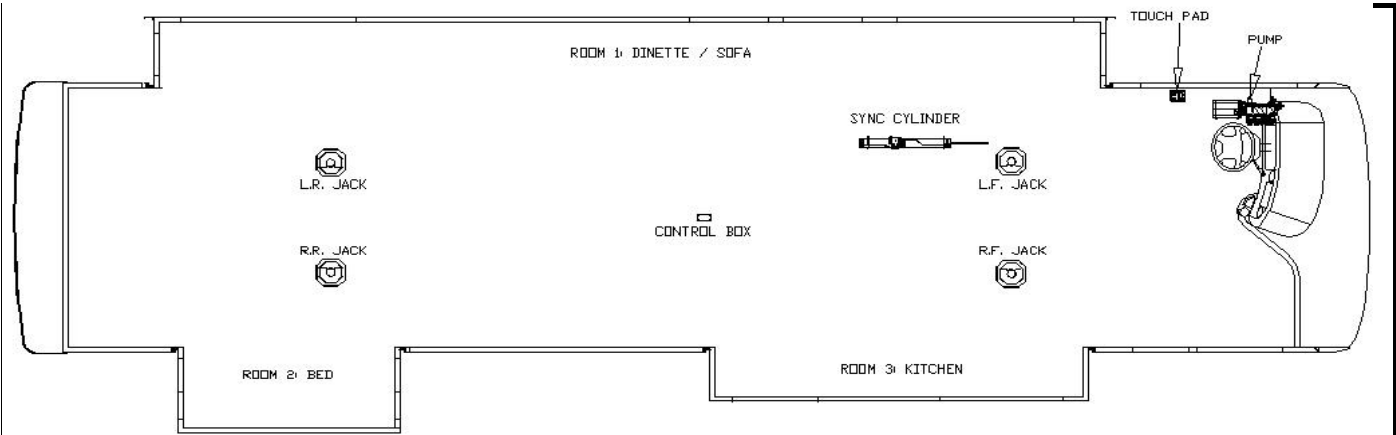

Notes:

- 1) Jacks mount to chassis brackets with the lowest holes of the jacks aligned with the lowest holes of the mounting brackets.
- 2) Level sensor attaches to bottom of structure; on the square tube the runs full length from axle to axle.
- 3) Hydraulic hose terminations for room #1 & #2 require 90 degree swivel elbows.
- 4) Room #1 will have a non-powered slide mechanism in center of room
- 5) Hoses marked w90 will have the 90 deg fitting shipped loose.

Item, Length	Description / Location	Qty	Color	Vendor PN		
Kit	(Items listed below)	1		8340	Measuring from inside of firewall, this is the end location of the hydraulic hoses where they attach to the slide mechanism.	
Pump	7-Function, 4 Rooms & Jacks	1		7319BR		
Jack	17,000 lbs, 18" Stroke	4		7134		
Touch Pad	Located to the left of the drivers seat	1		2318		
Control Box	Attached to bottom of structure	1		2730		
Sync Cylinder	Mounted behind LP tank	1		7397		
Hose, 144	Pump to Jack, Left Front	2	Brown	2467		
Hose, 396	Pump to Jack, Left Rear	2	Orange	2483		
Hose, 144	Pump to Jack, Right Front	2	White	2467		
Hose, 420	Pump to Jack, Right Rear	2	Yellow	2485		
Hose, 144	Pump to synchronizing cylinder	2	Green	2467		Mounts to bracket on structure
Hose w90, 432	Sync cylinder to front slide, Room 1	2	Green	2486		103 / Drivers side
Hose w90, 432	Sync cylinder to rear slide, Room 1	2	Green	2486		350 / Drivers side
Slide Unit	Room 1 - 24" flush floor slide (angled)	2		7388		
Slide Unit	Room 1 - 24" flush floor slide (angled)	1		7384		Slave
Hose, 480	Pump to Room 2	2	Purple	2490	345 / Passenger Side	
Slide Unit	Room 2 - 30" Bed slide (Lippert)	1		134998		
Hose w90, 228	Pump to Room 3	2	Gray	2474	146 / Passenger Side	
Slide Unit	Room 3 - 18" above floor slide	1		7135		
	Pump to Generator Slide	N/A			N/A	
Travel Clamp	(two per slide, except the bed slide)	4		HWH	N/A	
Options						

Revisions

1	UPDATE JPG	
2	Updated per ECN #4237	
3	Added equalizer slide units to chart ECN# 4438	
4	Corrected bed slide Vendor Part No. Was 143960	JS 8-15-07

**39G Presidio
EQUALIZER JACKS (FULLY AUTOMATIC)
STANDARD ON THIS UNIT**

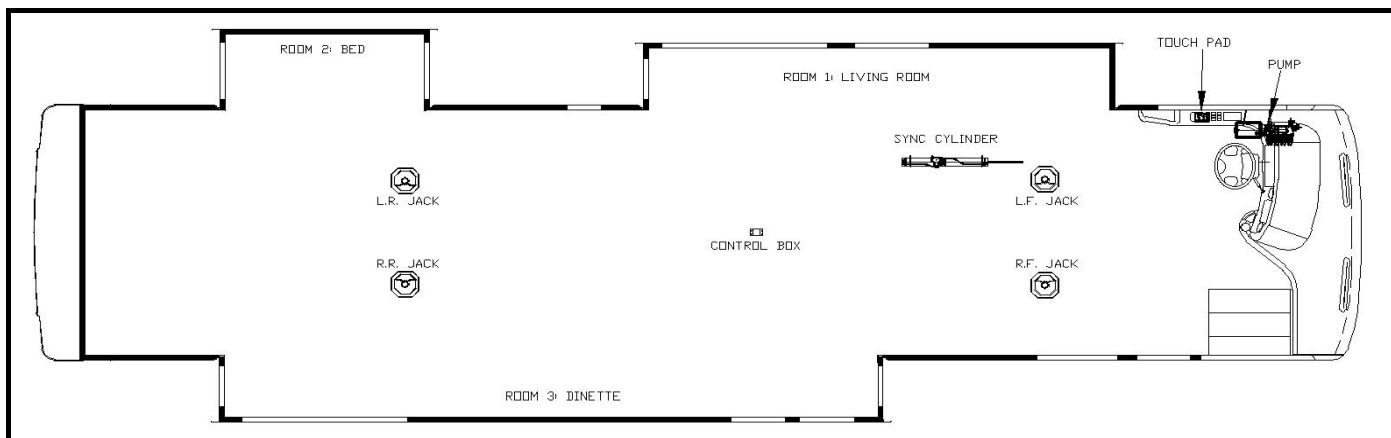

Notes:

- 1) Jacks mount to chassis brackets with the lowest holes of the jacks aligned with the lowest holes of the mounting brackets.
- 2) Level sensor attaches to bottom of structure; on the square tube the runs full length from axle to axle.
- 3) Hydraulic hose terminations for room #1 & #2 require 90 degree swivel elbows.
- 4) Room #1 will have a non-powered slide mechanism in center of room
- 5) Hoses marked w90 will have the 90 deg fitting shipped loose.

Item, Length	Description / Location	Qty	Color	Vendor PN		
Kit	(Items listed below)	1		8354	<p align="center">Measuring from inside of firewall, this is the end location of the hydraulic hoses where they attach to the slide mechanism.</p>	
Pump	7-Function, 3 Rooms & Jacks	1		7319BR		
Jack	17,000 lbs, 18" Stroke	4		7134		
Touch Pad	Located to the left of the drivers seat	1		2318		
Control Box	Attached to bottom of structure	1		2730		
Sync Cylinder	Mounted behind LP tank	2		7397		
Hose, 144	Pump to Jack, Left Front	2	Brown	2467		
Hose, 408	Pump to Jack, Left Rear	2	Orange	2484		
Hose, 144	Pump to Jack, Right Front	2	White	2467		
Hose, 408	Pump to Jack, Right Rear	2	Yellow	2484		
Hose, 144	Pump to synchronizing cylinder	2	Green	2467		
Hose w90, 168	Sync cylinder to front slide, Room 1	2	Green	2469		Mounts to bracket on structure 103 / Drivers side
Hose w90, 168	Sync cylinder to rear slide, Room 1	2	Green	2469		205 / Drivers side
Slide Unit	Room 1 - 24" flush floor slide (angled)	2		7388		
Hose w90, 360	Sync cylinder to front slide, Room 3	2	Gray	2527		205 / Passenger side
Hose w90, 360	Sync cylinder to rear slide, Room 3	2	Gray	2527		350 / Passenger side
Slide Unit	Room 3 - 24" flush floor slide (angled)	2		7388		
Hose, 480	Pump to Room 2	2	Purple	2490		345 / Drivers Side
Slide Unit	Room 2 - 30" Bed slide (Lippert)	1		134998		
	Pump to Generator Slide	N/A				N/A
Travel Clamp	(two per slide, except the bed slide)	4		HWH		N/A
Hose, 144	Pump to synchronizing cylinder	2	Gray	2467		Mounts to bracket on structure

Options

Revisions

1	Corrected picture
2	Corrected hose notes for room #3 & #1.....3-5-07
3	Added equalizer slide units to chart ECN# 4438
4	Corrected bed slide Vendor Part No. Was 143960 JS 8-15-07

**39H Presidio
EQUALIZER JACKS (FULLY AUTOMATIC)
STANDARD ON THIS UNIT**

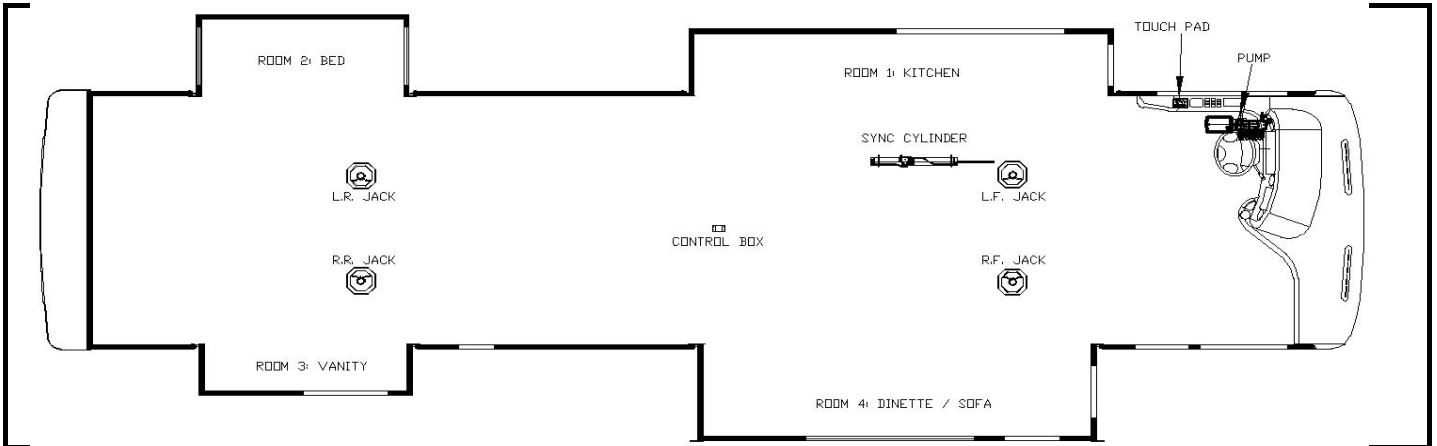

Notes:

- 1) Jacks mount to chassis brackets with the lowest holes of the jacks aligned with the lowest holes of the mounting brackets.
- 2) Level sensor attaches to bottom of structure; on the square tube the runs full length from axle to axle.
- 3) Hydraulic hose terminations for room #1, #3, & #4 require 90 degree swivel elbows.
- 4) Reference FM-3991 for a better visual of Room 4 hydraulic connections.
- 5) Hoses marked w90 will have the 90 deg fitting shipped loose.

Item, Length	Description / Location	Qty	Color	Vendor PN	
Kit	(Items listed below)	1		8393	
Pump	8-Function, 4 Rooms & Jacks	1		7302BR	
Jack	17,000 lbs, 18" Stroke	4		7134	
Touch Pad	Located to the left of the drivers seat	1		2318	
Control Box	Attached to bottom of structure	1		2730	
Sync Cylinder	(Room 1) Mounted behind LP tank	1		7511	
Sync Cylinder	(Room 4) Mounted behind LP tank	1		7397	
Hose, 144	Pump to Jack, Left Front	2	Brown	2467	
Hose, 408	Pump to Jack, Left Rear	2	Orange	2484	
Hose, 144	Pump to Jack, Right Front	2	White	2467	
Hose, 408	Pump to Jack, Right Rear	2	Yellow	2484	
Hose, 144	Pump to synchronizing cylinder	2	Green	2467	Mounts to bracket on structure
Hose, 144	Pump to synchronizing cylinder	2	Red	2467	Mounts to bracket on structure
Hose, 480	Pump to Room 2	2	Purple	2490	385 / Drivers Side
Slide Unit	Room 2 - 30" Bed slide (Lippert)	1		134998	
Hose w90, 432	Pump to Room 3	2	Gray	2486	363 / Passenger Side
Slide Unit	Room 3 - 18" above floor slide	1		7135	
Hose w90, 168	Sync cylinder to front slide, Room 1	2	Green	2469	116 / Drivers Side
Hose w90, 168	Sync cylinder to rear slide, Room 1	2	Green	2469	210 / Drivers Side
Slide Unit	Room 1 - 18" above floor slide	2		7135	
Hose w90, 168	Sync cylinder to front slide, Room 4	2	Red	2469	103 / Passenger side
Hose w90, 168	Sync cylinder to rear slide, Room 4	2	Red	2469	195 / Passenger side
Slide Unit	Room 4 - 24" flush floor slide (angled)	2		7388	
	Pump to Generator Slide	N/A			N/A
Travel Clamp	(two per slide, except the bed slide)	6		HWH	N/A

Measuring from inside of firewall, this is the end location of the hydraulic hoses where they attach to the slide mechanism.

Options

Revisions

**42A Presidio
EQUALIZER JACKS (FULLY AUTOMATIC)
STANDARD ON THIS UNIT**

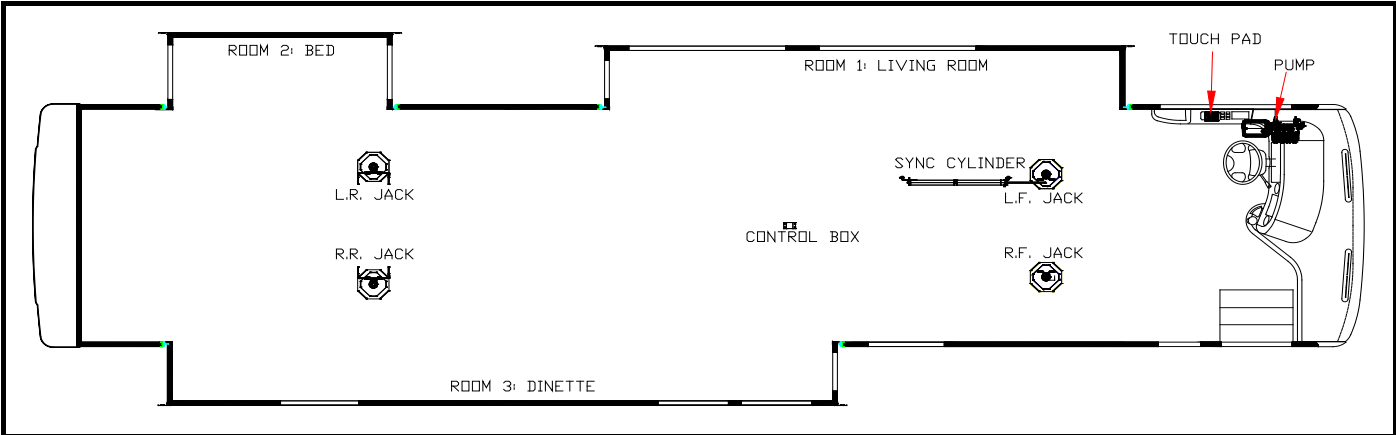

Notes:

- 1) Jacks mount to chassis brackets with the lowest holes of the jacks aligned with the lowest holes of the mounting brackets.
- 2) Level sensor attaches to bottom of structure; on the square tube the runs full length from axle to axle.
- 3) Hydraulic hose terminations for room #1 & #3 require 90 degree swivel elbows.
- 4) Hoses marked w90 will have the 90 deg fitting shipped loose.

Item, Length	Description / Location	Qty	Color	Vendor PN	
Kit	(Items listed below)	1		8373	
Pump	7-Function, 3 Rooms & Jacks	1		7319BR	Measuring from inside of firewall, this is the end location of the hydraulic hoses where they attach to the slide mechanism.
Jack	17,000 lbs, 18" Stroke	4		7134	
Touch Pad	Located to the left of the drivers seat	1		2318	
Control Box	Attached to bottom of structure	1		2730	
Sync Cylinder	Mounted behind LP tank	2		7397	
Hose, 144	Pump to Jack, Left Front	2	Brown	2467	
Hose, 408	Pump to Jack, Left Rear	2	Orange	2484	
Hose, 144	Pump to Jack, Right Front	2	White	2467	
Hose, 408	Pump to Jack, Right Rear	2	Yellow	2484	
Hose, 168	Pump to synchronizing cylinder	2	Green	2469	
Hose w90, 168	Sync cylinder to front slide, Room 1	2	Green	2469	Mounts to bracket on structure 130 / Drivers side
Hose w90, 168	Sync cylinder to rear slide, Room 1	2	Green	2469	220 / Drivers side
Slide Unit	Room 1 - 24" flush floor slide (angled)	2		7388	
Hose w90, 360	Sync cylinder to front slide, Room 3	2	Gray	2527	235 / Passenger side
Hose w90, 360	Sync cylinder to rear slide, Room 3	2	Gray	2527	385 / Passenger side
Slide Unit	Room 3 - 24" flush floor slide (angled)	2		7388	
Hose, 516	Pump to Room 2	2	Purple	2491	420 / Drivers Side
Slide Unit	Room 2 - 30" Bed slide (Lippert)	1		134998	
	Pump to Generator Slide	N/A			N/A
Travel Clamp	(two per slide, except the bed slide)	4		HWH	N/A
Hose, 168	Pump to synchronizing cylinder	2	Gray	2469	Mounts to bracket on structure

Options

Revisions

1	Updated before intial quote.	JES 8-9-07	
2	Corrected bed slide Vendor Part No. Was 143960	JS 8-15-07	

**42B Presidio
EQUALIZER JACKS (FULLY AUTOMATIC)
STANDARD ON THIS UNIT**

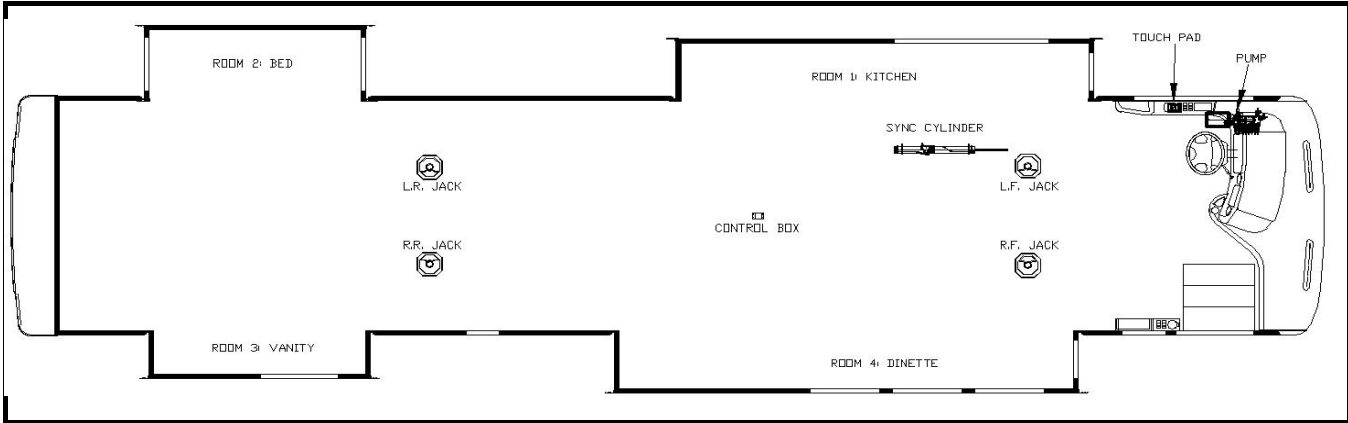

- Notes:**
- 1) Jacks mount to chassis brackets with the lowest holes of the jacks aligned with the lowest holes of the mounting brackets.
 - 2) Level sensor attaches to bottom of structure; on the square tube the runs full length from axle to axle.
 - 3) Hydraulic hose terminations for room #1 & #3 require 90 degree swivel elbows.
 - 4) Hoses marked w90 will have the 90 deg fitting shipped loose.

Item, Length	Description / Location	Qty	Color	Vendor PN	
Kit	(Items listed below)	1		8379	Measuring from inside of firewall, this is the end location of the hydraulic hoses where they attach to the slide mechanism.
Pump	8-Function, 4 Rooms & Jacks	1		7302BR	
Jack	17,000 lbs, 18" Stroke	4		7134	
Touch Pad	Located to the left of the drivers seat	1		2318	
Control Box	Attached to bottom of structure	1		2730	
Sync Cylinder	Mounted behind LP tank	2		7397	
Hose, 144	Pump to Jack, Left Front	2	Brown	2467	
Hose, 408	Pump to Jack, Left Rear	2	Orange	2484	
Hose, 144	Pump to Jack, Right Front	2	White	2467	
Hose, 408	Pump to Jack, Right Rear	2	Yellow	2484	
Hose, 168	Pump to synchronizing cylinder	2	Green	2469	Mounts to bracket on structure
Hose, 168	Pump to synchronizing cylinder	2	Red	2469	Mounts to bracket on structure
Hose w90, 168	Sync cylinder to front slide, Room 1	2	Green	2469	115 / Drivers side
Hose w90, 168	Sync cylinder to rear slide, Room 1	2	Green	2469	205 / Drivers side
Slide Unit	Room 1 - 24" flush floor slide (angled)	2		7388	
Hose, 516	Pump to Room 2	2	Purple	2491	420 / Drivers Side
Slide Unit	Room 2 - 30" Bed slide (Lippert)	1		134998	
Hose w90, 516	Pump to Room 3	2	Gray	2491	404 / Passenger side
Slide Unit	Room 3 - 18" above floor slide	1		7135	
Hose w90, 288	Sync cylinder to front slide, Room 4	2	Red	2478	115 / Passenger side
Hose w90, 288	Sync cylinder to rear slide, Room 4	2	Red	2478	254 / Passenger side
Slide Unit	Room 4 - 24" flush floor slide (angled)	2		7388	
	Pump to Generator Slide	N/A			N/A
Travel Clamp	(two per slide, except the bed slide)	6		HWH	N/A

Options

Revisions

**40E Mandalay
EQUALIZER JACKS (FULLY AUTOMATIC)
STANDARD ON THIS UNIT**

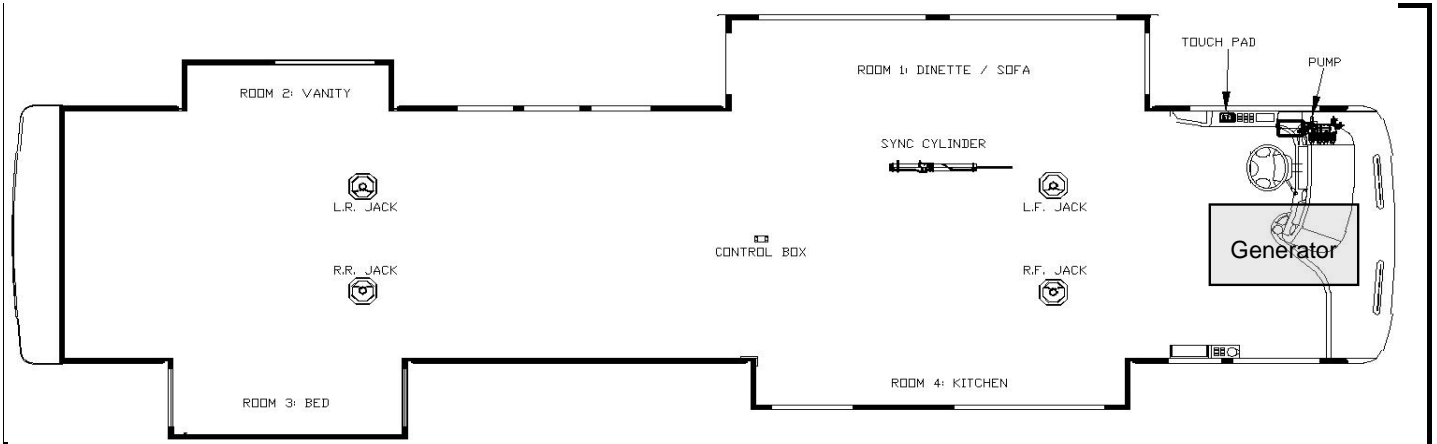

Notes:

- 1) Jacks mount to chassis brackets providing 8-9 inches of ground clearance with the air bags dumped.
- 2) Level sensor attaches to bottom of structure; on lower hat section flanges or square tube.
- 3) Hydraulic hose terminations for room #1, #2, & #4 require 90 degree swivel elbows.
- 4) Hoses marked w90 will have the 90 deg. Fitting shipped loose

Item, Length	Description / Location	Qty	Color	Vendor PN	
Kit	(Items listed below)	1		8359	
Pump	9-Function, 4 Rooms, & Jacks	1		7464BR	Measuring from inside of firewall, this is the end location of the hydraulic hoses where they attach to the slide mechanism.
Jack	17,000 lbs, 18" Stroke	4		7134	
Touch Pad	Located to the left of the drivers seat	1		2318	
Control Box	Attached to bottom of structure	1		2730	
Sync Cylinder	Mounted behind LP tank	1		7387	
Hose, 144	Pump to Jack, Left Front	2	Brown	2467	
Hose, 480	Pump to Jack, Left Rear	2	Orange	2490	
Hose, 144	Pump to Jack, Right Front	2	White	2467	
Hose, 480	Pump to Jack, Right Rear	2	Yellow	2490	
Hose, 144	Pump to synchronizing cylinder	2	Green	2467	
Hose w90, 168	Sync cylinder to front slide, Room 1	2	Green	2469	103 / Drivers side
Hose w90, 168	Sync cylinder to rear slide, Room 1	2	Green	2469	196 / Drivers side
	Pump to Room 1	N/A	Green		
Hose w90, 432	Pump to Room 2	2	Purple	2486	373 / Drivers Side
Hose, 480	Pump to Room 3	2	Gray	2490	352 / Passenger Side
Hose w90, 228	Pump to Room 4	2	Red	2474	153 / Passenger Side
Hose, 60	Pump to Generator Slide	2	Blue	2460	Inside generator tray
Travel Clamp	(two per slide, except the bed slide)	6		HWH	N/A

Options

Revisions

**40F Mandalay
EQUALIZER JACKS (FULLY AUTOMATIC)
STANDARD ON THIS UNIT**

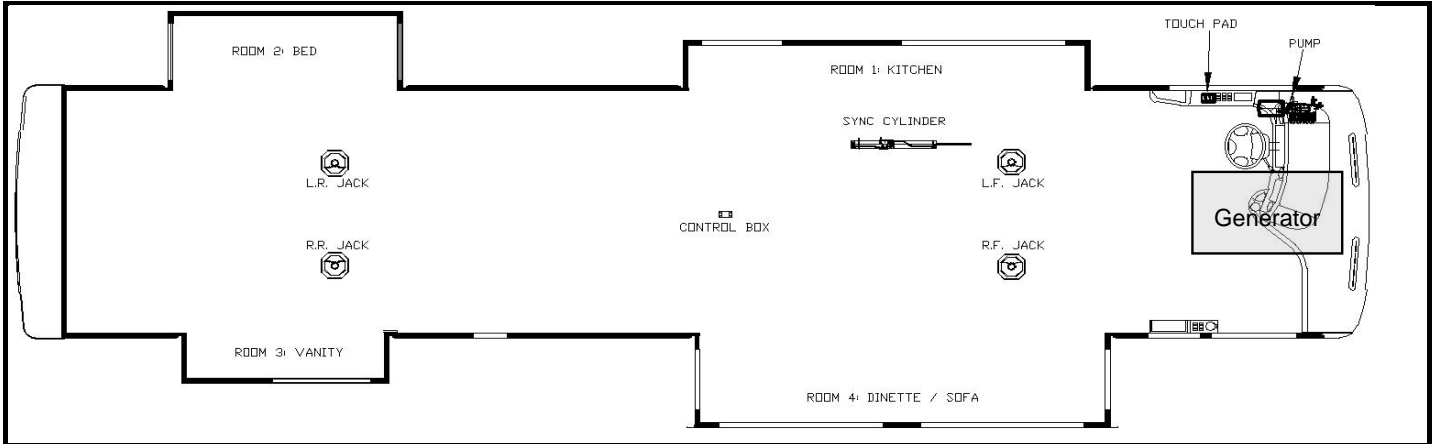

Notes:

- 1) Jacks mount to chassis brackets providing 8-9 inches of ground clearance with the air bags dumped.
- 2) Level sensor attaches to bottom of structure; on lower hat section flanges or square tube.
- 3) Hydraulic hose terminations for room #1, #3, & #4 require 90 degree swivel elbows.
- 4) Hoses marked w90 will have the 90 deg. Fitting shipped loose

Item, Length	Description / Location	Qty	Color	Vendor PN		
Kit	(Items listed below)	1		8278		
Pump	9-Function, 4 Rooms, & Jacks	1		7302		
Jack	17,000 lbs, 18" Stroke	4		7134	Measuring from inside of firewall, this is the end location of the hydraulic hoses where they attach to the slide mechanism.	
Touch Pad	Located to the left of the drivers seat	1		2318		
Control Box	Attached to bottom of structure	1		2319		
Sync Cylinder	Mounted behind LP tank	1		7387		
Hose, 144	Pump to Jack, Left Front	2	Brown	2467		
Hose, 480	Pump to Jack, Left Rear	2	Orange	2490		
Hose, 144	Pump to Jack, Right Front	2	White	2467		
Hose, 480	Pump to Jack, Right Rear	2	Yellow	2490		
Hose, 144	Pump to synchronizing cylinder	2	Green	2467		mounts to bracket on structure
Hose w90, 168	Sync cylinder to front slide, Room 4	1	Green	2469		103 / Passenger side
Hose w90, 168	Sync cylinder to rear slide, Room 4	1	Green	2469	196 / Passenger side	
Hose w90, 168	Pump to Room 1	2	Green	2469	151 / Driver Side	
Hose, 480	Pump to Room 2	2	Purple	2490	353 / Drivers Side	
Hose w90, 432	Pump to Room 3	2	Gray	2486	386 / Passenger Side	
	Pump to Room 4	N/A	Red			
Hose, 60	Pump to Generator Slide	2			Inside generator tray	
Travel Clamp	(two per slide, except the bed slide)	6		HWH	N/A	

Options

Revisions

**40G Mandalay
EQUALIZER JACKS (FULLY AUTOMATIC)
STANDARD ON THIS UNIT**

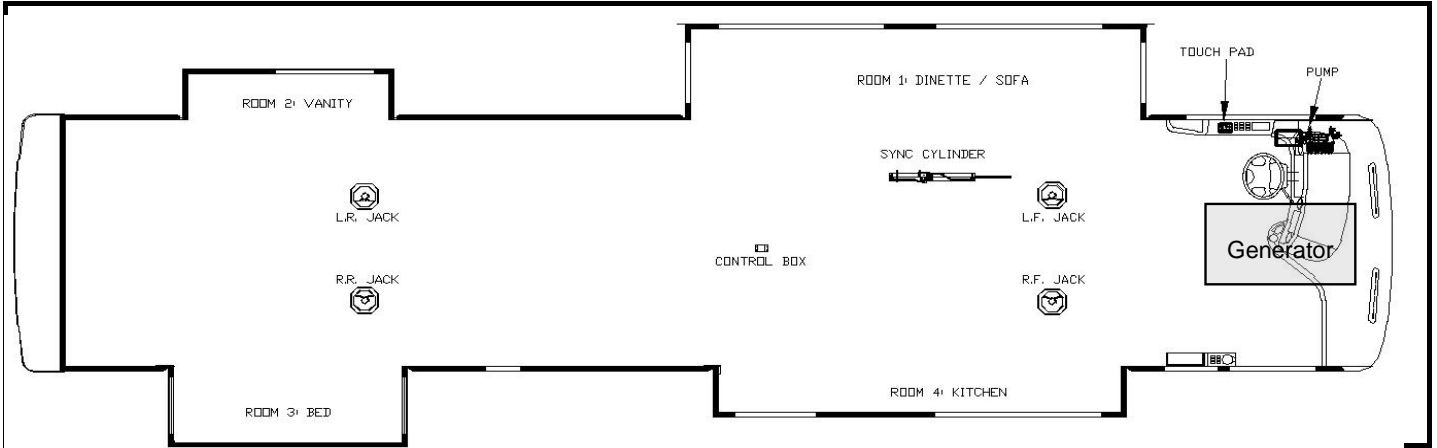

Notes:

- 1) Jacks mount to chassis brackets providing 8-9 inches of ground clearance with the air bags dumped.
- 2) Level sensor attaches to bottom of structure; on lower hat section flanges or square tube.
- 3) Hydraulic hose terminations for room #1, #3, & #4 require 90 degree swivel elbows.
- 4) Hoses marked w90 will have the 90 deg. Fitting shipped loose

Item, Length	Description / Location	Qty	Color	Vendor PN	
Kit	(Items listed below)	1		8359	
Pump	9-Function, 4 Rooms, & Jacks	1		7464BR	Measuring from inside of firewall, this is the end location of the hydraulic hoses where they attach to the slide mechanism.
Jack	17,000 lbs, 18" Stroke	4		7134	
Touch Pad	Located to the left of the drivers seat	1		2318	
Control Box	Attached to bottom of structure	1		2730	
Sync Cylinder	Mounted behind LP tank	1		7387	
Hose, 144	Pump to Jack, Left Front	2	Brown	2467	
Hose, 480	Pump to Jack, Left Rear	2	Orange	2490	
Hose, 144	Pump to Jack, Right Front	2	White	2467	
Hose, 480	Pump to Jack, Right Rear	2	Yellow	2490	
Hose, 144	Pump to synchronizing cylinder	2	Green	2467	
Hose w90, 168	Sync cylinder to front slide, Room 1	2	Green	2469	99 / Drivers side
Hose w90, 168	Sync cylinder to rear slide, Room 1	2	Green	2469	201 / Drivers side
	Pump to Room 1	N/A	Green		
Hose w90, 432	Pump to Room 2	2	Purple	2486	373 / Drivers Side
Hose, 480	Pump to Room 3	2	Gray	2490	352 / Passenger Side
Hose w90, 228	Pump to Room 4	2	Red	2474	153 / Passenger Side
Hose, 60	Pump to Generator Slide	2	Blue	2460	Inside generator tray
Travel Clamp	(two per slide, except the bed slide)	6		HWH	N/A

Options

Revisions

**40H Mandalay
EQUALIZER JACKS (FULLY AUTOMATIC)
STANDARD ON THIS UNIT**

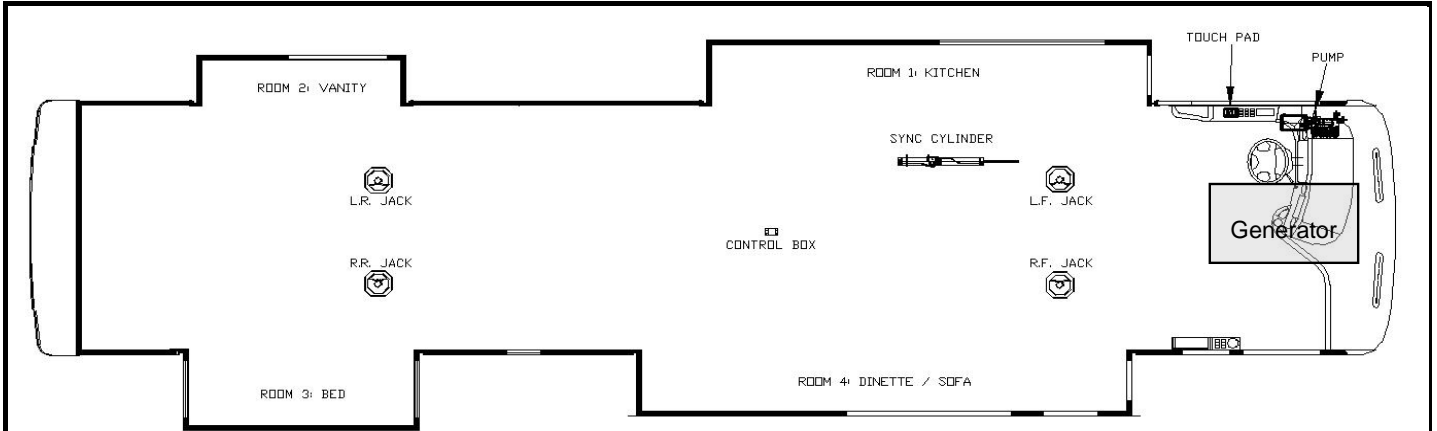

Notes:

- 1) Jacks mount to chassis brackets providing 8-9 inches of ground clearance with the air bags dumped.
- 2) Level sensor attaches to bottom of structure; on lower hat section flanges or square tube.
- 3) Hydraulic hose terminations for room #1, #3, & #4 require 90 degree swivel elbows.
- 4) Hoses marked w90 will have the 90 deg. Fitting shipped loose

Item, Length	Description / Location	Qty	Color	Vendor PN	
Kit	(Items listed below)	1		8357	
Pump	9-Function, 4 Rooms, & Jacks	1		7464BR	
Jack	17,000 lbs, 18" Stroke	4		7134	
Touch Pad	Located to the left of the drivers seat	1		2318	
Control Box	Attached to bottom of structure	1		2730	
Sync Cylinder	Mounted behind LP tank	2		7397	
Hose, 144	Pump to Jack, Left Front	2	Brown	2467	
Hose, 480	Pump to Jack, Left Rear	2	Orange	2490	
Hose, 144	Pump to Jack, Right Front	2	White	2467	
Hose, 480	Pump to Jack, Right Rear	2	Yellow	2490	
Hose, 144	Pump to synchronizing cylinder	2	Green	2467	Mounts to bracket on structure
Hose, 144	Pump to synchronizing cylinder	2	Red	2467	Mounts to bracket on structure
Hose, 480	Pump to Room 2	2	Purple	2490	325 / Drivers Side
Slide Unit	Room 2-18" above floor slide)	1		7469	
Hose w90, 432	Pump to Room 3	2	Gray	2486	355 / Passenger Side
Slide Unit	Room 3-30" Bed slide (Lippert)	1		134998	
Hose w90, 168	Sync cylinder to front slide, Room 1	2	Green	2469	95 / Drivers Side
Hose w90, 168	Sync cylinder to rear slide, Room 1	2	Green	2469	180 / Drivers Side
Slide Unit	Room 1-24" flush floor slide (angled)	2		7477	
Hose w90, 168	Sync cylinder to front slide, Room 4	2	Red	2469	103 / Passenger side
Hose w90, 168	Sync cylinder to rear slide, Room 4	2	Red	2469	196 / Passenger side
Slide Unit	Room 4-24" flush floor slide (angled)	2		7477	
Hose, 60	Pump to Generator Slide	2	Blue	2460	Inside generator tray
Travel Clamp	(two per slide, except the bed slide)	6		HWH	N/A

Measuring from inside of firewall, this is the end location of the hydraulic hoses where they attach to the slide mechanism.

Options

Revisions

43A Mandalay
EQUALIZER JACKS (FULLY AUTOMATIC)
STANDARD ON THIS UNIT

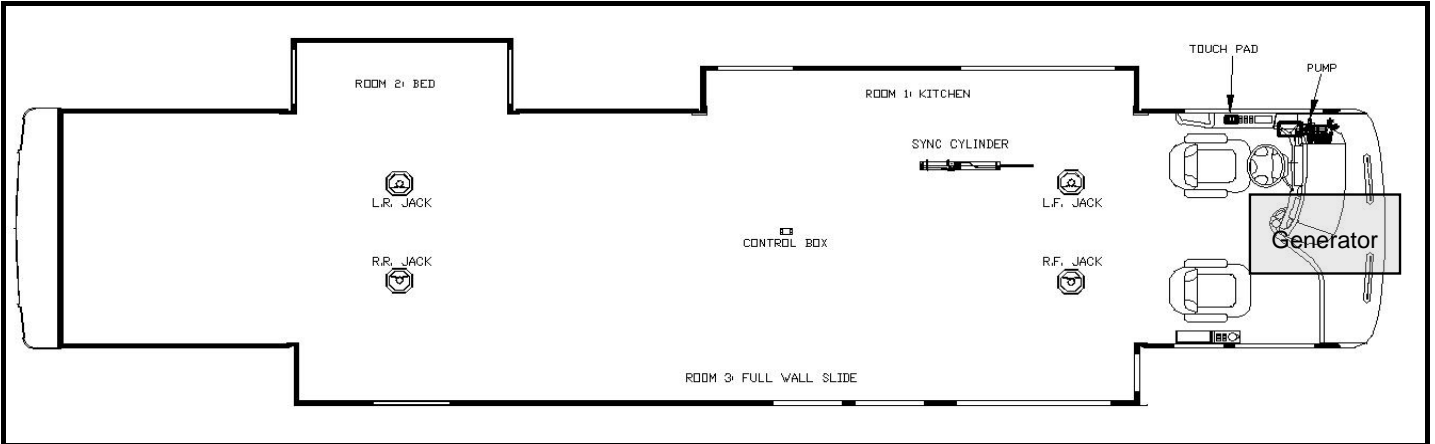

Notes:

- 1) Jacks mount to chassis brackets providing 8-9 inches of ground clearance with the air bags dumped.
- 2) Level sensor attaches to bottom of structure; on lower hat section flanges or square tube.
- 3) Hydraulic hose terminations for room #1 & #3 require 90 degree swivel elbows.
- 4) Hoses marked w90 will have the 90 deg. Fitting shipped loose
- 5) All in floor slides to have automatic travel lock sensor

Item, Length	Description / Location	Qty	Color	Vendor PN	
Kit	(Items listed below)	1		8360	
Pump	8-Function, 3 Rooms, & Jacks	1		7474BR	
Jack	17,000 lbs, 18" Stroke	4		7134	
Touch Pad	Located to the left of the drivers seat	1		2318	
Control Box	Attached to bottom of structure	1		2730	
Sync Cylinder	Mounted behind LP tank	1		7397	
Hose, 144	Pump to Jack, Left Front	2	Brown	2467	
Hose, 480	Pump to Jack, Left Rear	2	Orange	2490	
Hose, 144	Pump to Jack, Right Front	2	White	2467	
Hose, 480	Pump to Jack, Right Rear	2	Yellow	2490	
Hose, 144	Pump to synchronizing cylinder	2	Grey	2467	Mounts to bracket on structure
Hose, 216	Pump to Room 1	2	Green	2473	165 / Drivers Side
Slide Unit	Room 1 - 18" above floor slide	1		7469	
Hose w90, 516	Pump to Room 2	2	Purple	2491	408 / Drivers Side
Slide Unit	Room 2 - 30" Bed slide (Lippert)	1		134998	
Hose w90, 288	Sync cylinder to front slide, Room 3	2	Grey	2478	90 / Passenger side
Hose w90, 288	Sync cylinder to rear slide, Room 3	2	Grey	2478	378 / Passenger side
Slide Unit	Room 3 - 24" flush floor slide (angled)	2		7477	
Slide Unit	Room 3 - 24" flush floor slide (angled)	1		7384	Slave
Hose, 60	Pump to Generator Slide	2	Red	2460	Inside generator tray
Travel Clamp	(two per slide, except the bed slide)	4		HWH	N/A

Measuring from inside of firewall, this is the end location of the hydraulic hoses where they attach to the slide mechanism.

Options

Options					

Revisions

Revisions					
1	Corrected the bed slide Vendor Part No. Was 143960.	8-15-07	JS		

**43B Mandalay
EQUALIZER JACKS (FULLY AUTOMATIC)
STANDARD ON THIS UNIT**

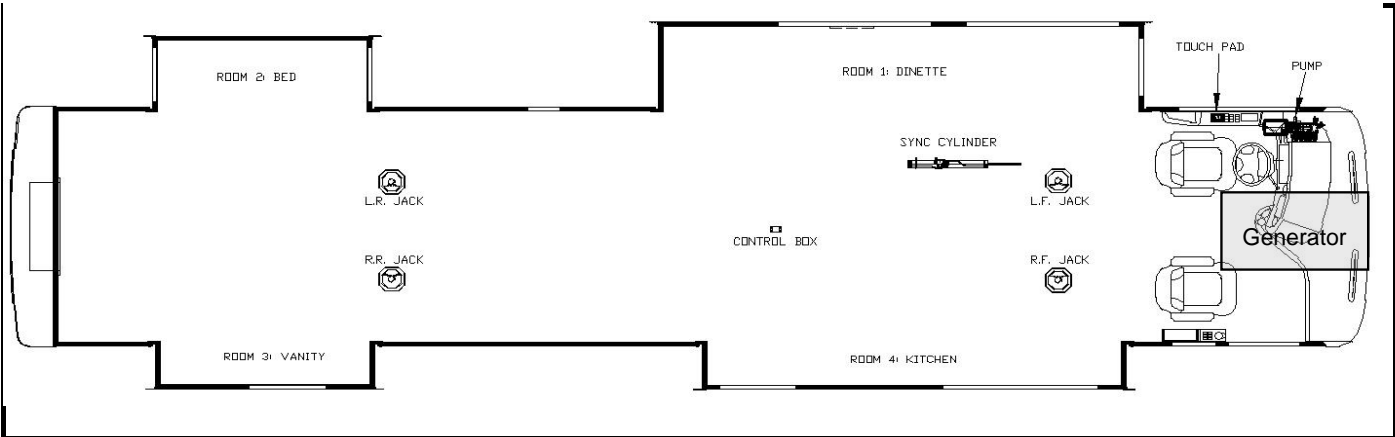

Notes:

- 1) Jacks mount to chassis brackets providing 8-9 inches of ground clearance with the air bags dumped.
- 2) Level sensor attaches to bottom of structure; on lower hat section flanges or square tube.
- 3) Hydraulic hose terminations for room #1, #3 & #4 require 90 degree swivel elbows.
- 4) Hoses marked w90 will have the 90 deg. Fitting shipped loose
- 5) All in floor slides to have automatic travel lock sensor

Item, Length	Description / Location	Qty	Color	Vendor PN	
Kit	(Items listed below)	1		8364	
Pump	9-Function, 4 Rooms, & Jacks	1		7464BR	Measuring from inside of firewall, this is the end location of the hydraulic hoses where they attach to the slide mechanism.
Jack	17,000 lbs, 18" Stroke	4		7134	
Touch Pad	Located to the left of the drivers seat	1		2318	
Control Box	Attached to bottom of structure	1		2730	
Sync Cylinder	Mounted behind LP tank	1		7387	
Hose, 144	Pump to Jack, Left Front	2	Brown	2467	
Hose, 480	Pump to Jack, Left Rear	2	Orange	2490	
Hose, 144	Pump to Jack, Right Front	2	White	2467	
Hose, 480	Pump to Jack, Right Rear	2	Yellow	2490	
Hose, 144	Pump to synchronizing cylinder	2	Green	2467	
Hose w90, 216	Sync cylinder to front slide, Room 1	2	Green	2473	Mounts to bracket on structure 110 / Drivers Side
Hose w90, 216	Sync cylinder to rear slide, Room 1	2	Green	2473	256 / Drivers Side
Slide Unit	Room 1 - 36" flush floor slide (angled)	2		7481	
Hose, 516	Pump to Room 2	2	Purple	2491	408 / Drivers Side
Slide Unit	Room 2 - 30" Bed slide (Lippert)	1		134998	
Hose w90, 480	Pump to Room 3	2	Grey	2490	408 / Passenger side
Slide Unit	Room 3 - 18" above floor slide	1		7469	
Hose w90, 204	Pump to Room 4	2	Red	2472	164 / Passenger side
Slide Unit	Room 4 - 18" above floor slide	1		7469	
Hose, 60	Pump to Generator Slide	2	Blue	2460	Inside generator tray
Travel Clamp	(two per slide, except the bed slide)	6		HWH	N/A

Options

Item, Length	Description / Location	Qty	Color	Vendor PN	

Revisions

1	Corrected the bed slide Vendor Part No. Was 143960.	8-15-07	JS	
2	Chg'd Room 1 Sync cylinder hose lengths from 276" (PN 2477) to 216" (PN 2473).	8-31-07	KK	

**43C Mandalay
EQUALIZER JACKS (FULLY AUTOMATIC)
STANDARD ON THIS UNIT**

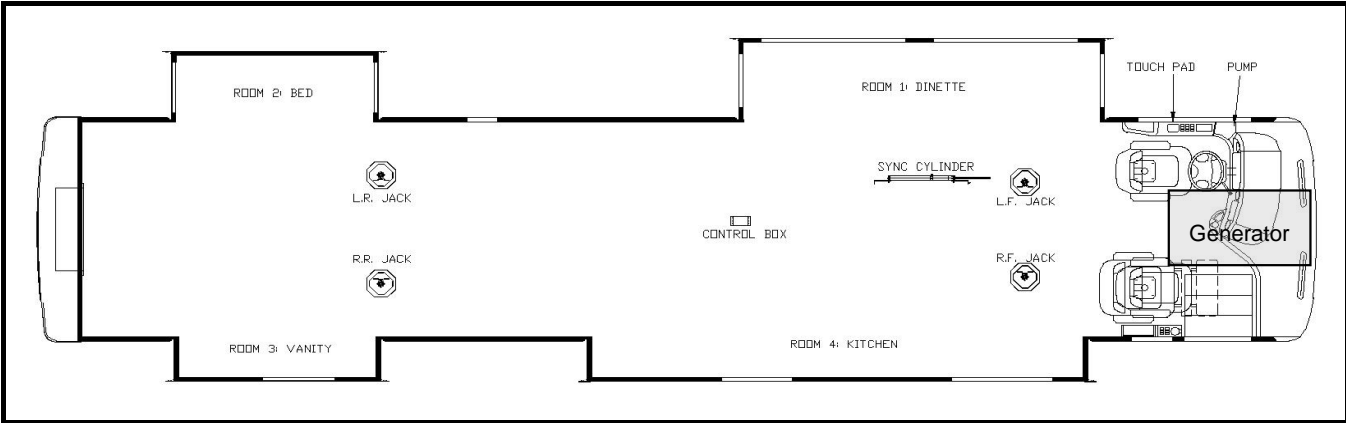

- Notes:**
- 1) Jacks mount to chassis brackets providing 8-9 inches of ground clearance with the air bags dumped.
 - 2) Level sensor attaches to bottom of structure; on lower hat section flanges or square tube.
 - 3) Hydraulic hose terminations for room #1, #3 & #4 require 90 degree swivel elbows.
 - 4) Hoses marked w90 will have the 90 deg. Fitting shipped loose
 - 5) All in floor slides to have automatic travel lock sensor

Item, Length	Description / Location	Qty	Color	Vendor PN		
Kit	(Items listed below)	1		8377	Measuring from inside of firewall, this is the end location of the hydraulic hoses where they attach to the slide mechanism.	
Pump	9-Function, 4 Rooms, & Jacks	1		7464BR		
Jack	17,000 lbs, 18" Stroke	4		7134		
Touch Pad	Located to the left of the drivers seat	1		2318		
Control Box	Attached to bottom of structure	1		2730		
Sync Cylinder	Mounted behind LP tank, Room 1	1		7387		
Sync Cylinder	Mounted behind LP tank, Room 4	1		7511		
Hose, 144	Pump to Jack, Left Front	2	Brown	2467		
Hose, 480	Pump to Jack, Left Rear	2	Orange	2490		
Hose, 144	Pump to Jack, Right Front	2	White	2467		
Hose, 480	Pump to Jack, Right Rear	2	Yellow	2490		
Hose, 180	Pump to synchronizing cylinder	2	Green	2470		Mounts to bracket on structure
Hose w90, 168	Sync cylinder to front slide, Room 1	2	Green	2469		99 / Drivers Side
Hose w90, 168	Sync cylinder to rear slide, Room 1	2	Green	2469		187 / Drivers Side
Slide Unit	Room 1 - 36" flush floor slide (angled)	2		7481		
Hose, 516	Pump to Room 2	2	Purple	2491	408 / Drivers Side	
Slide Unit	Room 2 - 30" Bed slide (Lippert)	1		134998		
Hose w90, 456	Pump to Room 3	2	Grey	2488	408 / Passenger side	
Slide Unit	Room 3 - 18" above floor slide	1		7469		
Hose, 180	Pump to synchronizing cylinder	2	Red	2470	Mounts to bracket on structure	
Hose w90, 228	Sync cylinder to front slide, Room 4	2	Red	2474	135 / Passenger Side	
Hose w90, 228	Sync cylinder to rear slide, Room 4	2	Red	2474	220 / Passenger Side	
Slide Unit	Room 4 - 18" above floor slide	2		7469		
Hose, 60	Pump to Generator Slide	2	Blue	2460	Inside generator tray	
Travel Clamp	(two per slide, except the bed slide)	6		HWH	N/A	

Options					

Revisions					

**40E Mandalay
EQUALIZER JACKS (FULLY AUTOMATIC)
STANDARD ON THIS UNIT**

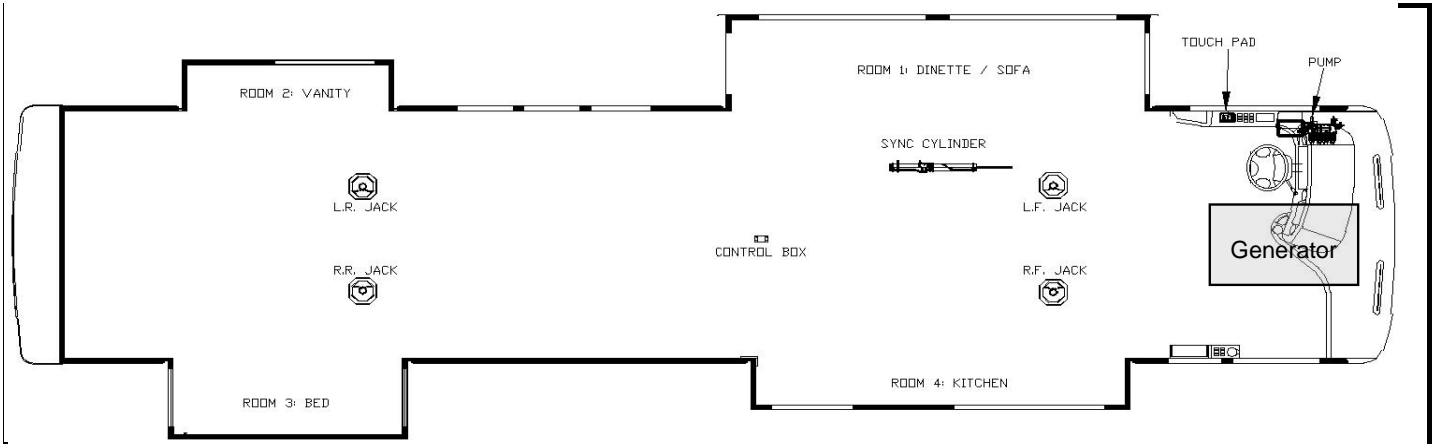

Notes:

- 1) Jacks mount to chassis brackets providing 8-9 inches of ground clearance with the air bags dumped.
- 2) Level sensor attaches to bottom of structure; on lower hat section flanges or square tube.
- 3) Hydraulic hose terminations for room #1, #2, & #4 require 90 degree swivel elbows.
- 4) Hoses marked w90 will have the 90 deg. Fitting shipped loose

Item, Length	Description / Location	Qty	Color	Vendor PN	
Kit	(Items listed below)	1		8359	
Pump	9-Function, 4 Rooms, & Jacks	1		7464BR	
Jack	17,000 lbs, 18" Stroke	4		7134	
Touch Pad	Located to the left of the drivers seat	1		2318	
Control Box	Attached to bottom of structure	1		2730	
Sync Cylinder	Mounted behind LP tank	1		7387	
Hose, 144	Pump to Jack, Left Front	2	Brown	2467	
Hose, 480	Pump to Jack, Left Rear	2	Orange	2490	
Hose, 144	Pump to Jack, Right Front	2	White	2467	
Hose, 480	Pump to Jack, Right Rear	2	Yellow	2490	
Hose, 144	Pump to synchronizing cylinder	2	Green	2467	mounts to bracket on structure
Hose w90, 168	Sync cylinder to front slide, Room 1	2	Green	2469	103 / Drivers side
Hose w90, 168	Sync cylinder to rear slide, Room 1	2	Green	2469	196 / Drivers side
	Pump to Room 1	N/A	Green		
Hose w90, 432	Pump to Room 2	2	Purple	2486	373 / Drivers Side
Hose, 480	Pump to Room 3	2	Gray	2490	352 / Passenger Side
Hose w90, 228	Pump to Room 4	2	Red	2474	153 / Passenger Side
Hose, 60	Pump to Generator Slide	2	Blue	2460	Inside generator tray
Travel Clamp	(two per slide, except the bed slide)	6		HWH	N/A

Measuring from inside of firewall, this is the end location of the hydraulic hoses where they attach to the slide mechanism.

Options

Revisions

**40F Mandalay
EQUALIZER JACKS (FULLY AUTOMATIC)
STANDARD ON THIS UNIT**

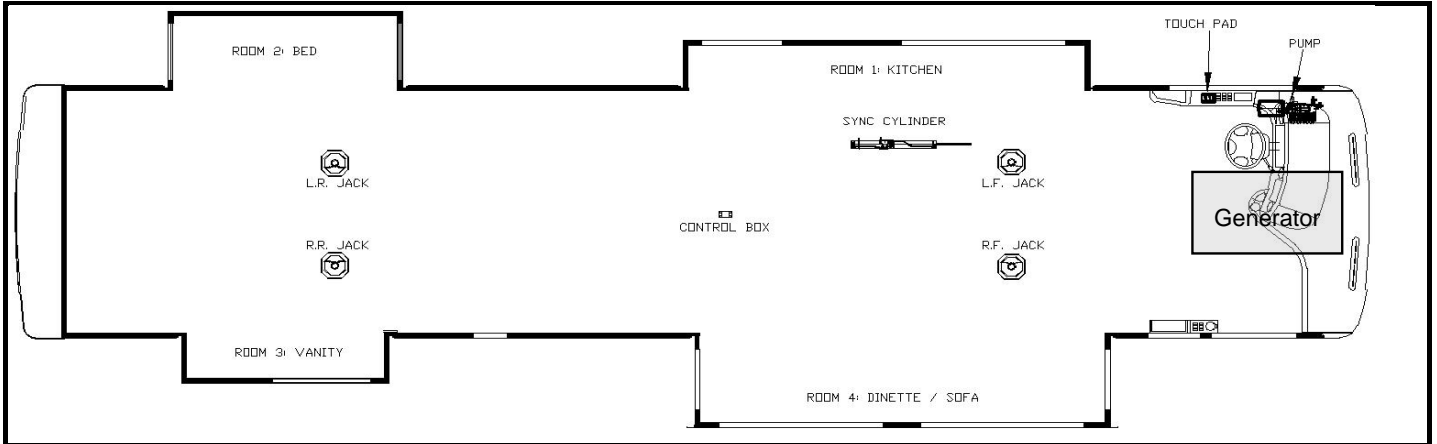

- Notes:**
- 1) Jacks mount to chassis brackets providing 8-9 inches of ground clearance with the air bags dumped.
 - 2) Level sensor attaches to bottom of structure; on lower hat section flanges or square tube.
 - 3) Hydraulic hose terminations for room #1, #3, & #4 require 90 degree swivel elbows.
 - 4) Hoses marked w90 will have the 90 deg. Fitting shipped loose

Item, Length	Description / Location	Qty	Color	Vendor PN	
Kit	(Items listed below)	1		8278	
Pump	9-Function, 4 Rooms, & Jacks	1		7302	
Jack	17,000 lbs, 18" Stroke	4		7134	
Touch Pad	Located to the left of the drivers seat	1		2318	
Control Box	Attached to bottom of structure	1		2319	
Sync Cylinder	Mounted behind LP tank	1		7387	
Hose, 144	Pump to Jack, Left Front	2	Brown	2467	
Hose, 480	Pump to Jack, Left Rear	2	Orange	2490	
Hose, 144	Pump to Jack, Right Front	2	White	2467	
Hose, 480	Pump to Jack, Right Rear	2	Yellow	2490	
Hose, 144	Pump to synchronizing cylinder	2	Green	2467	mounts to bracket on structure
Hose w90, 168	Sync cylinder to front slide, Room 4	1	Green	2469	103 / Passenger side
Hose w90, 168	Sync cylinder to rear slide, Room 4	1	Green	2469	196 / Passenger side
Hose w90, 168	Pump to Room 1	2	Green	2469	151 / Driver Side
Hose, 480	Pump to Room 2	2	Purple	2490	353 / Drivers Side
Hose w90, 432	Pump to Room 3	2	Gray	2486	386 / Passenger Side
	Pump to Room 4	N/A	Red		
Hose, 60	Pump to Generator Slide	2			Inside generator tray
Travel Clamp	(two per slide, except the bed slide)	6		HWH	N/A

Measuring from inside of firewall, this is the end location of the hydraulic hoses where they attach to the slide mechanism.

Options					

Revisions					

**40G Mandalay
EQUALIZER JACKS (FULLY AUTOMATIC)
STANDARD ON THIS UNIT**

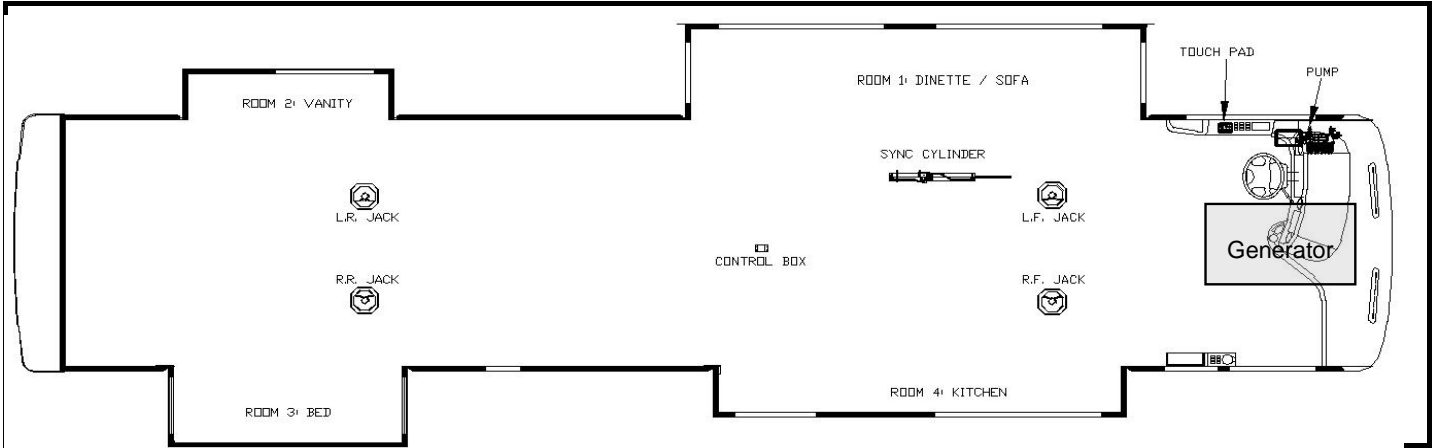

Notes:

- 1) Jacks mount to chassis brackets providing 8-9 inches of ground clearance with the air bags dumped.
- 2) Level sensor attaches to bottom of structure; on lower hat section flanges or square tube.
- 3) Hydraulic hose terminations for room #1, #3, & #4 require 90 degree swivel elbows.
- 4) Hoses marked w90 will have the 90 deg. Fitting shipped loose

Item, Length	Description / Location	Qty	Color	Vendor PN	
Kit	(Items listed below)	1		8359	
Pump	9-Function, 4 Rooms, & Jacks	1		7464BR	Measuring from inside of firewall, this is the end location of the hydraulic hoses where they attach to the slide mechanism.
Jack	17,000 lbs, 18" Stroke	4		7134	
Touch Pad	Located to the left of the drivers seat	1		2318	
Control Box	Attached to bottom of structure	1		2730	
Sync Cylinder	Mounted behind LP tank	1		7387	
Hose, 144	Pump to Jack, Left Front	2	Brown	2467	
Hose, 480	Pump to Jack, Left Rear	2	Orange	2490	
Hose, 144	Pump to Jack, Right Front	2	White	2467	
Hose, 480	Pump to Jack, Right Rear	2	Yellow	2490	
Hose, 144	Pump to synchronizing cylinder	2	Green	2467	
Hose w90, 168	Sync cylinder to front slide, Room 1	2	Green	2469	99 / Drivers side
Hose w90, 168	Sync cylinder to rear slide, Room 1	2	Green	2469	201 / Drivers side
	Pump to Room 1	N/A	Green		
Hose w90, 432	Pump to Room 2	2	Purple	2486	373 / Drivers Side
Hose, 480	Pump to Room 3	2	Gray	2490	352 / Passenger Side
Hose w90, 228	Pump to Room 4	2	Red	2474	153 / Passenger Side
Hose, 60	Pump to Generator Slide	2	Blue	2460	Inside generator tray
Travel Clamp	(two per slide, except the bed slide)	6		HWH	N/A

Options

Revisions

**40H Mandalay
EQUALIZER JACKS (FULLY AUTOMATIC)
STANDARD ON THIS UNIT**

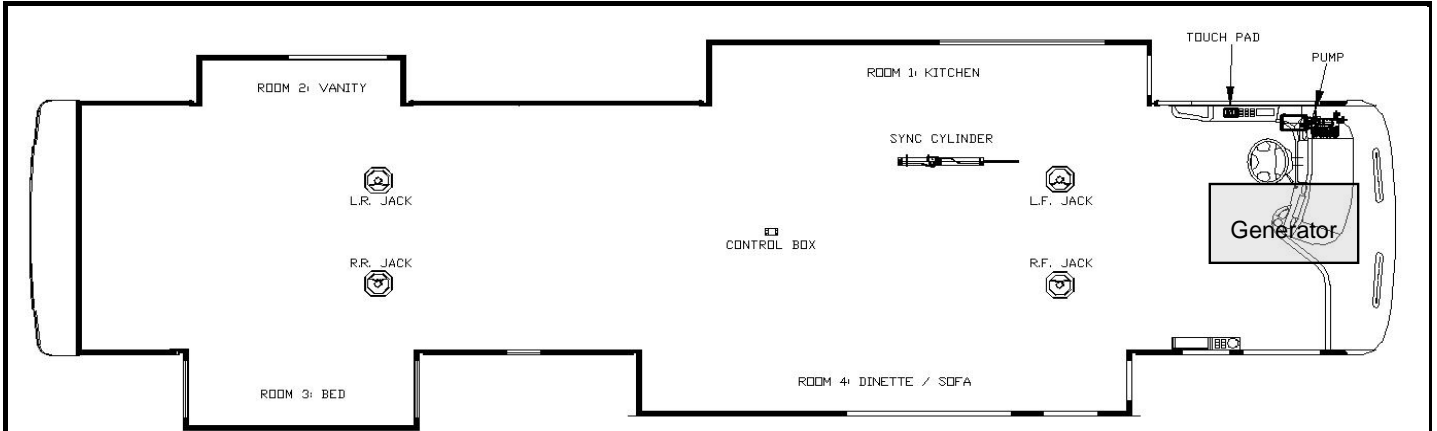

Notes:

- 1) Jacks mount to chassis brackets providing 8-9 inches of ground clearance with the air bags dumped.
- 2) Level sensor attaches to bottom of structure; on lower hat section flanges or square tube.
- 3) Hydraulic hose terminations for room #1, #3, & #4 require 90 degree swivel elbows.
- 4) Hoses marked w90 will have the 90 deg. Fitting shipped loose

Item, Length	Description / Location	Qty	Color	Vendor PN	
Kit	(Items listed below)	1		8357	
Pump	9-Function, 4 Rooms, & Jacks	1		7464BR	Measuring from inside of firewall, this is the end location of the hydraulic hoses where they attach to the slide mechanism.
Jack	17,000 lbs, 18" Stroke	4		7134	
Touch Pad	Located to the left of the drivers seat	1		2318	
Control Box	Attached to bottom of structure	1		2730	
Sync Cylinder	Mounted behind LP tank	2		7397	
Hose, 144	Pump to Jack, Left Front	2	Brown	2467	
Hose, 480	Pump to Jack, Left Rear	2	Orange	2490	
Hose, 144	Pump to Jack, Right Front	2	White	2467	
Hose, 480	Pump to Jack, Right Rear	2	Yellow	2490	
Hose, 144	Pump to synchronizing cylinder	2	Green	2467	
Hose, 144	Pump to synchronizing cylinder	2	Red	2467	Mounts to bracket on structure
Hose, 480	Pump to Room 2	2	Purple	2490	325 / Drivers Side
Hose w90, 432	Pump to Room 3	2	Gray	2486	355 / Passenger Side
Hose w90, 168	Sync cylinder to front slide, Room 1	2	Green	2469	95 / Drivers Side
Hose w90, 168	Sync cylinder to rear slide, Room 1	2	Green	2469	180 / Drivers Side
Hose w90, 168	Sync cylinder to front slide, Room 4	2	Red	2469	103 / Passenger side
Hose w90, 168	Sync cylinder to rear slide, Room 4	2	Red	2469	196 / Passenger side
Hose, 60	Pump to Generator Slide	2	Blue	2460	Inside generator tray
Travel Clamp	(two per slide, except the bed slide)	6		HWH	N/A

Options

Revisions

43A Mandalay
EQUALIZER JACKS (FULLY AUTOMATIC)
STANDARD ON THIS UNIT

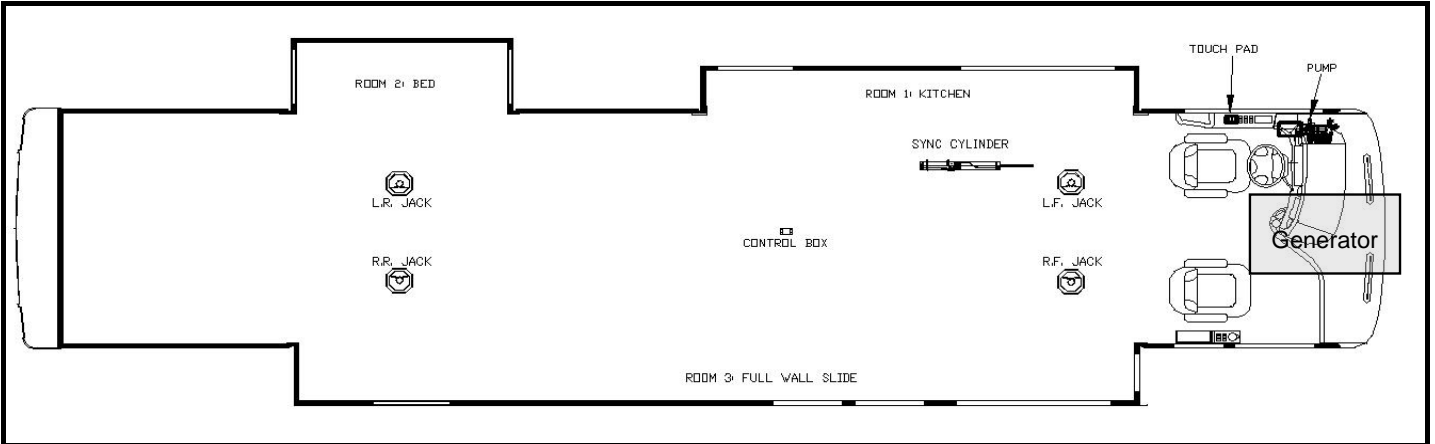

Notes:

- 1) Jacks mount to chassis brackets providing 8-9 inches of ground clearance with the air bags dumped.
- 2) Level sensor attaches to bottom of structure; on lower hat section flanges or square tube.
- 3) Hydraulic hose terminations for room #1 & #3 require 90 degree swivel elbows.
- 4) Hoses marked w90 will have the 90 deg. Fitting shipped loose
- 5) All in floor slides to have automatic travel lock sensor

Item, Length	Description / Location	Qty	Color	Vendor PN	
Kit	(Items listed below)	1		8360	
Pump	8-Function, 3 Rooms, & Jacks	1		7474BR	
Jack	17,000 lbs, 18" Stroke	4		7134	
Touch Pad	Located to the left of the drivers seat	1		2318	
Control Box	Attached to bottom of structure	1		2730	
Sync Cylinder	Mounted behind LP tank	1		7397	
Hose, 144	Pump to Jack, Left Front	2	Brown	2467	
Hose, 480	Pump to Jack, Left Rear	2	Orange	2490	
Hose, 144	Pump to Jack, Right Front	2	White	2467	
Hose, 480	Pump to Jack, Right Rear	2	Yellow	2490	
Hose, 144	Pump to synchronizing cylinder	2	Grey	2467	Mounts to bracket on structure
Hose, 168	Pump to Room 1	2	Green	2490	165 / Drivers Side
Slide Unit	Room 1 - 18" above floor slide	1		7469	
Hose w90, 432	Pump to Room 2	2	Purple	2486	408 / Drivers Side
Slide Unit	Room 2 - 30" Bed slide (Lippert)	1		143960	
Hose w90, 204	Sync cylinder to front slide, Room 3	2	Grey	2469	90 / Passenger side
Hose w90, 204	Sync cylinder to rear slide, Room 3	2	Grey	2469	378 / Passenger side
Slide Unit	Room 3 - 24" flush floor slide (angled)	2		7477	
Slide Unit	Room 3 - 24" flush floor slide (angled)	1		7384	Slave
Hose, 60	Pump to Generator Slide	2	Red	2460	Inside generator tray
Travel Clamp	(two per slide, except the bed slide)	4		HWH	N/A

Measuring from inside of firewall, this is the end location of the hydraulic hoses where they attach to the slide mechanism.

Options

Revisions

**40E Mandalay
EQUALIZER JACKS (FULLY AUTOMATIC)
STANDARD ON THIS UNIT**

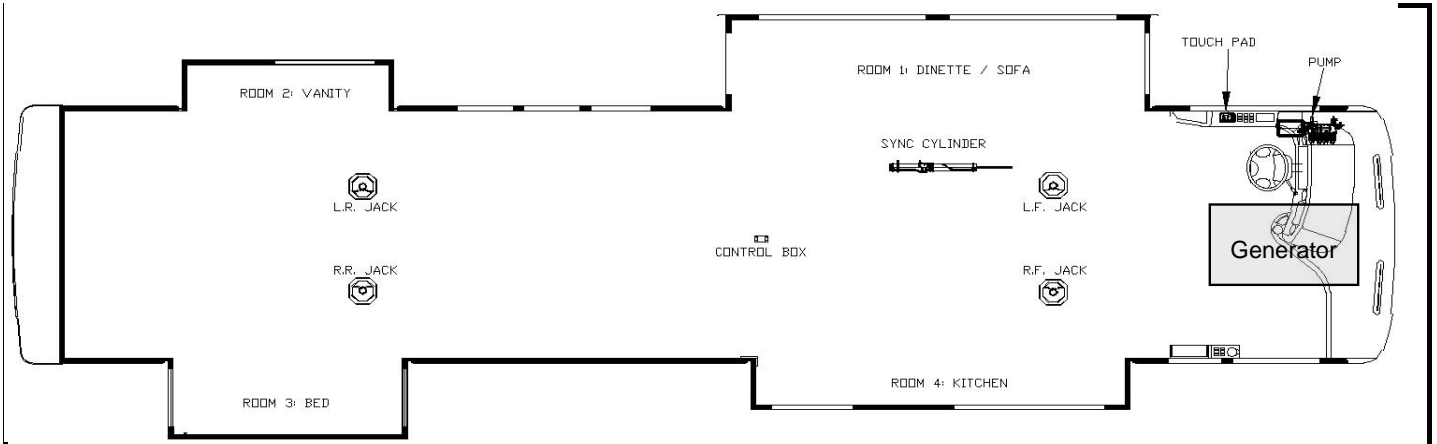

Notes:

- 1) Jacks mount to chassis brackets providing 8-9 inches of ground clearance with the air bags dumped.
- 2) Level sensor attaches to bottom of structure; on lower hat section flanges or square tube.
- 3) Hydraulic hose terminations for room #1, #2, & #4 require 90 degree swivel elbows.
- 4) Hoses marked w90 will have the 90 deg. Fitting shipped loose

Item, Length	Description / Location	Qty	Color	Vendor PN	
Kit	(Items listed below)	1		8359	
Pump	9-Function, 4 Rooms, & Jacks	1		7464BR	Measuring from inside of firewall, this is the end location of the hydraulic hoses where they attach to the slide mechanism.
Jack	17,000 lbs, 18" Stroke	4		7134	
Touch Pad	Located to the left of the drivers seat	1		2318	
Control Box	Attached to bottom of structure	1		2730	
Sync Cylinder	Mounted behind LP tank	1		7387	
Hose, 144	Pump to Jack, Left Front	2	Brown	2467	
Hose, 480	Pump to Jack, Left Rear	2	Orange	2490	
Hose, 144	Pump to Jack, Right Front	2	White	2467	
Hose, 480	Pump to Jack, Right Rear	2	Yellow	2490	
Hose, 144	Pump to synchronizing cylinder	2	Green	2467	
Hose w90, 168	Sync cylinder to front slide, Room 1	2	Green	2469	103 / Drivers side
Hose w90, 168	Sync cylinder to rear slide, Room 1	2	Green	2469	196 / Drivers side
	Pump to Room 1	N/A	Green		
Hose w90, 432	Pump to Room 2	2	Purple	2486	373 / Drivers Side
Hose, 480	Pump to Room 3	2	Gray	2490	352 / Passenger Side
Hose w90, 228	Pump to Room 4	2	Red	2474	153 / Passenger Side
Hose, 60	Pump to Generator Slide	2	Blue	2460	Inside generator tray
Travel Clamp	(two per slide, except the bed slide)	6		HWH	N/A

Options

Revisions

**40F Mandalay
EQUALIZER JACKS (FULLY AUTOMATIC)
STANDARD ON THIS UNIT**

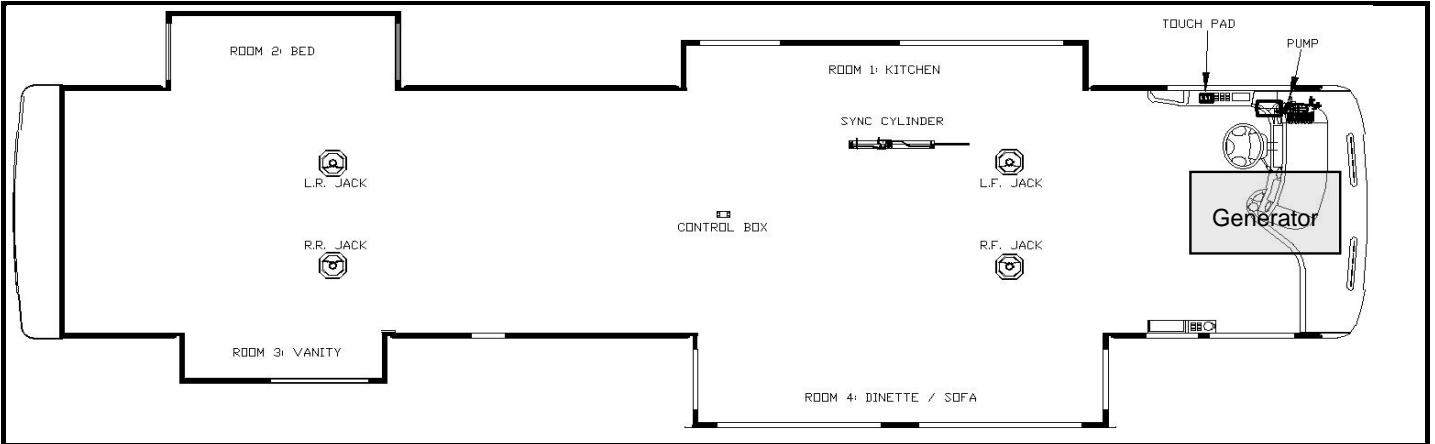

Notes:

- 1) Jacks mount to chassis brackets providing 8-9 inches of ground clearance with the air bags dumped.
- 2) Level sensor attaches to bottom of structure; on lower hat section flanges or square tube.
- 3) Hydraulic hose terminations for room #1, #3, & #4 require 90 degree swivel elbows.
- 4) Hoses marked w90 will have the 90 deg. Fitting shipped loose

Item, Length	Description / Location	Qty	Color	Vendor PN	
Kit	(Items listed below)	1		8278	
Pump	9-Function, 4 Rooms, & Jacks	1		7302	
Jack	17,000 lbs, 18" Stroke	4		7134	
Touch Pad	Located to the left of the drivers seat	1		2318	
Control Box	Attached to bottom of structure	1		2319	
Sync Cylinder	Mounted behind LP tank	1		7387	
Hose, 144	Pump to Jack, Left Front	2	Brown	2467	
Hose, 480	Pump to Jack, Left Rear	2	Orange	2490	
Hose, 144	Pump to Jack, Right Front	2	White	2467	
Hose, 480	Pump to Jack, Right Rear	2	Yellow	2490	
Hose, 144	Pump to synchronizing cylinder	2	Green	2467	mounts to bracket on structure
Hose w90, 168	Sync cylinder to front slide, Room 4	1	Green	2469	103 / Passenger side
Hose w90, 168	Sync cylinder to rear slide, Room 4	1	Green	2469	196 / Passenger side
Hose w90, 168	Pump to Room 1	2	Green	2469	151 / Driver Side
Hose, 480	Pump to Room 2	2	Purple	2490	353 / Drivers Side
Hose w90, 432	Pump to Room 3	2	Gray	2486	386 / Passenger Side
	Pump to Room 4	N/A	Red		
Hose, 60	Pump to Generator Slide	2			Inside generator tray
Travel Clamp	(two per slide, except the bed slide)	6		HWH	N/A

Measuring from inside of firewall, this is the end location of the hydraulic hoses where they attach to the slide mechanism.

Options

Revisions

**40G Mandalay
EQUALIZER JACKS (FULLY AUTOMATIC)
STANDARD ON THIS UNIT**

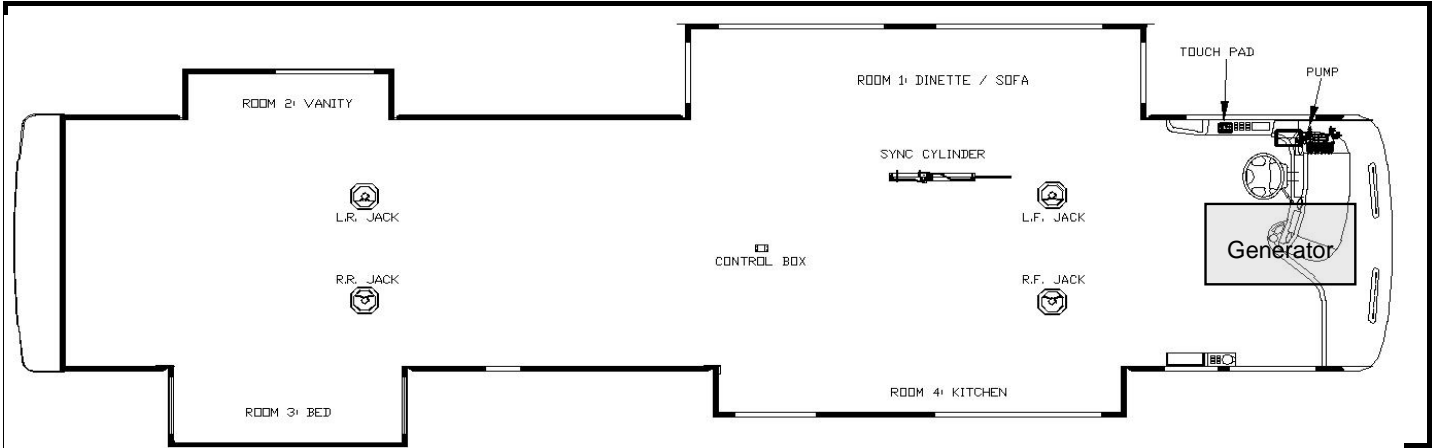

Notes:

- 1) Jacks mount to chassis brackets providing 8-9 inches of ground clearance with the air bags dumped.
- 2) Level sensor attaches to bottom of structure; on lower hat section flanges or square tube.
- 3) Hydraulic hose terminations for room #1, #3, & #4 require 90 degree swivel elbows.
- 4) Hoses marked w90 will have the 90 deg. Fitting shipped loose

Item, Length	Description / Location	Qty	Color	Vendor PN	
Kit	(Items listed below)	1		8359	
Pump	9-Function, 4 Rooms, & Jacks	1		7464BR	Measuring from inside of firewall, this is the end location of the hydraulic hoses where they attach to the slide mechanism.
Jack	17,000 lbs, 18" Stroke	4		7134	
Touch Pad	Located to the left of the drivers seat	1		2318	
Control Box	Attached to bottom of structure	1		2730	
Sync Cylinder	Mounted behind LP tank	1		7387	
Hose, 144	Pump to Jack, Left Front	2	Brown	2467	
Hose, 480	Pump to Jack, Left Rear	2	Orange	2490	
Hose, 144	Pump to Jack, Right Front	2	White	2467	
Hose, 480	Pump to Jack, Right Rear	2	Yellow	2490	
Hose, 144	Pump to synchronizing cylinder	2	Green	2467	
Hose w90, 168	Sync cylinder to front slide, Room 1	2	Green	2469	99 / Drivers side
Hose w90, 168	Sync cylinder to rear slide, Room 1	2	Green	2469	201 / Drivers side
	Pump to Room 1	N/A	Green		
Hose w90, 432	Pump to Room 2	2	Purple	2486	373 / Drivers Side
Hose, 480	Pump to Room 3	2	Gray	2490	352 / Passenger Side
Hose w90, 228	Pump to Room 4	2	Red	2474	153 / Passenger Side
Hose, 60	Pump to Generator Slide	2	Blue	2460	Inside generator tray
Travel Clamp	(two per slide, except the bed slide)	6		HWH	N/A

Options

Revisions

**40H Mandalay
EQUALIZER JACKS (FULLY AUTOMATIC)
STANDARD ON THIS UNIT**

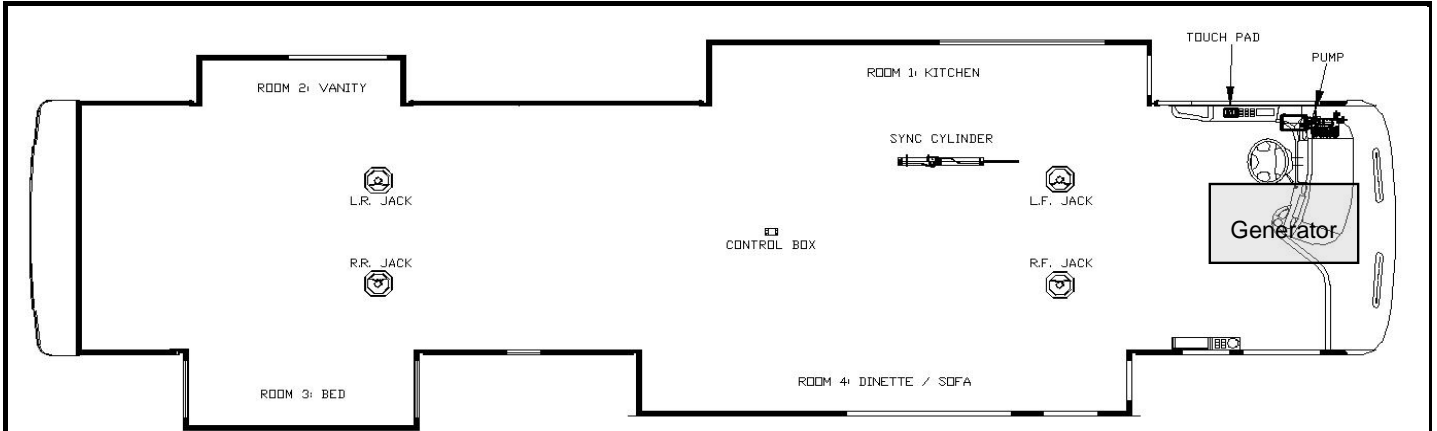

Notes:

- 1) Jacks mount to chassis brackets providing 8-9 inches of ground clearance with the air bags dumped.
- 2) Level sensor attaches to bottom of structure; on lower hat section flanges or square tube.
- 3) Hydraulic hose terminations for room #1, #3, & #4 require 90 degree swivel elbows.
- 4) Hoses marked w90 will have the 90 deg. Fitting shipped loose

Item, Length	Description / Location	Qty	Color	Vendor PN	
Kit	(Items listed below)	1		8357	
Pump	9-Function, 4 Rooms, & Jacks	1		7464BR	Measuring from inside of firewall, this is the end location of the hydraulic hoses where they attach to the slide mechanism.
Jack	17,000 lbs, 18" Stroke	4		7134	
Touch Pad	Located to the left of the drivers seat	1		2318	
Control Box	Attached to bottom of structure	1		2730	
Sync Cylinder	Mounted behind LP tank	2		7397	
Hose, 144	Pump to Jack, Left Front	2	Brown	2467	
Hose, 480	Pump to Jack, Left Rear	2	Orange	2490	
Hose, 144	Pump to Jack, Right Front	2	White	2467	
Hose, 480	Pump to Jack, Right Rear	2	Yellow	2490	
Hose, 144	Pump to synchronizing cylinder	2	Green	2467	
Hose, 144	Pump to synchronizing cylinder	2	Red	2467	Mounts to bracket on structure
Hose, 480	Pump to Room 2	2	Purple	2490	325 / Drivers Side
Hose w90, 432	Pump to Room 3	2	Gray	2486	355 / Passenger Side
Hose w90, 168	Sync cylinder to front slide, Room 1	2	Green	2469	95 / Drivers Side
Hose w90, 168	Sync cylinder to rear slide, Room 1	2	Green	2469	180 / Drivers Side
Hose w90, 168	Sync cylinder to front slide, Room 4	2	Red	2469	103 / Passenger side
Hose w90, 168	Sync cylinder to rear slide, Room 4	2	Red	2469	196 / Passenger side
Hose, 60	Pump to Generator Slide	2	Blue	2460	Inside generator tray
Travel Clamp	(two per slide, except the bed slide)	6		HWH	N/A

Options

Revisions

43A Mandalay
EQUALIZER JACKS (FULLY AUTOMATIC)
STANDARD ON THIS UNIT

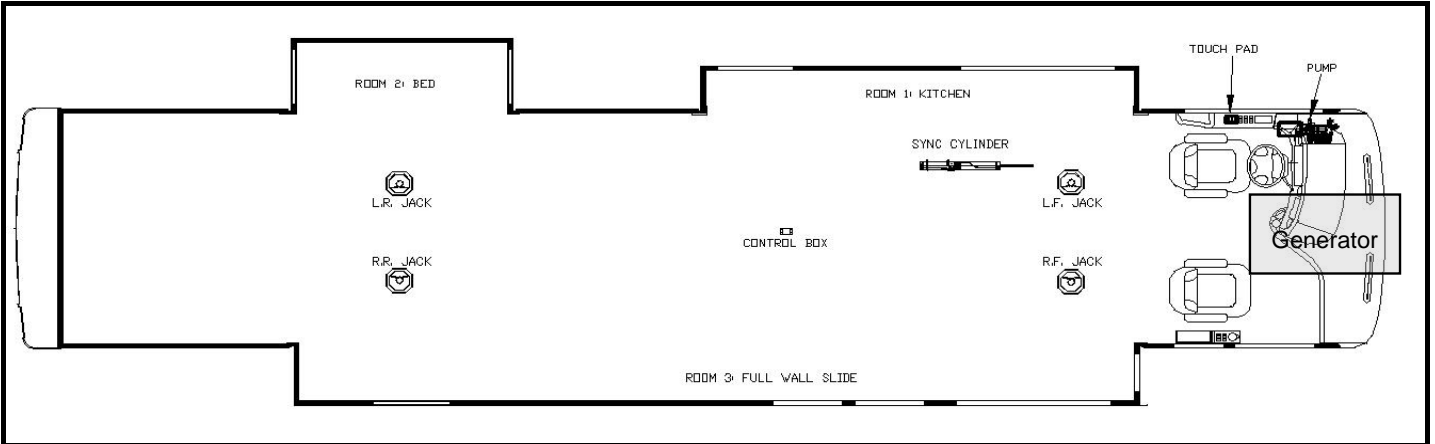

Notes:

- 1) Jacks mount to chassis brackets providing 8-9 inches of ground clearance with the air bags dumped.
- 2) Level sensor attaches to bottom of structure; on lower hat section flanges or square tube.
- 3) Hydraulic hose terminations for room #1 & #3 require 90 degree swivel elbows.
- 4) Hoses marked w90 will have the 90 deg. Fitting shipped loose
- 5) All in floor slides to have automatic travel lock sensor

Item, Length	Description / Location	Qty	Color	Vendor PN	
Kit	(Items listed below)	1		8360	
Pump	8-Function, 3 Rooms, & Jacks	1		7474BR	
Jack	17,000 lbs, 18" Stroke	4		7134	
Touch Pad	Located to the left of the drivers seat	1		2318	
Control Box	Attached to bottom of structure	1		2730	
Sync Cylinder	Mounted behind LP tank	1		7397	
Hose, 144	Pump to Jack, Left Front	2	Brown	2467	
Hose, 480	Pump to Jack, Left Rear	2	Orange	2490	
Hose, 144	Pump to Jack, Right Front	2	White	2467	
Hose, 480	Pump to Jack, Right Rear	2	Yellow	2490	
Hose, 144	Pump to synchronizing cylinder	2	Grey	2467	Mounts to bracket on structure
Hose, 216	Pump to Room 1	2	Green	2473	165 / Drivers Side
Slide Unit	Room 1 - 18" above floor slide	1		7469	
Hose w90, 516	Pump to Room 2	2	Purple	2491	408 / Drivers Side
Slide Unit	Room 2 - 30" Bed slide (Lippert)	1		143960	
Hose w90, 288	Sync cylinder to front slide, Room 3	2	Grey	2478	90 / Passenger side
Hose w90, 288	Sync cylinder to rear slide, Room 3	2	Grey	2478	378 / Passenger side
Slide Unit	Room 3 - 24" flush floor slide (angled)	2		7477	
Slide Unit	Room 3 - 24" flush floor slide (angled)	1		7384	Slave
Hose, 60	Pump to Generator Slide	2	Red	2460	Inside generator tray
Travel Clamp	(two per slide, except the bed slide)	4		HWH	N/A

Measuring from inside of firewall, this is the end location of the hydraulic hoses where they attach to the slide mechanism.

Options

Item, Length	Description / Location	Qty	Color	Vendor PN	

Revisions

Rev	Description

**40E Mandalay
EQUALIZER JACKS (FULLY AUTOMATIC)
STANDARD ON THIS UNIT**

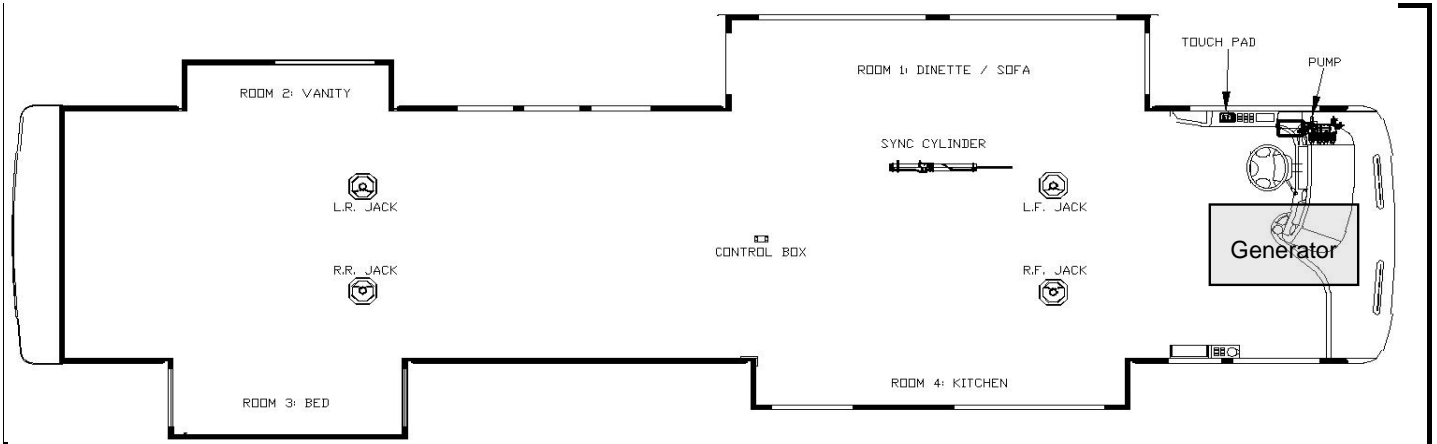

Notes:

- 1) Jacks mount to chassis brackets providing 8-9 inches of ground clearance with the air bags dumped.
- 2) Level sensor attaches to bottom of structure; on lower hat section flanges or square tube.
- 3) Hydraulic hose terminations for room #1, #2, & #4 require 90 degree swivel elbows.
- 4) Hoses marked w90 will have the 90 deg. Fitting shipped loose

Item, Length	Description / Location	Qty	Color	Vendor PN	
Kit	(Items listed below)	1		8359	
Pump	9-Function, 4 Rooms, & Jacks	1		7464BR	
Jack	17,000 lbs, 18" Stroke	4		7134	
Touch Pad	Located to the left of the drivers seat	1		2318	
Control Box	Attached to bottom of structure	1		2730	
Sync Cylinder	Mounted behind LP tank	1		7387	
Hose, 144	Pump to Jack, Left Front	2	Brown	2467	
Hose, 480	Pump to Jack, Left Rear	2	Orange	2490	
Hose, 144	Pump to Jack, Right Front	2	White	2467	
Hose, 480	Pump to Jack, Right Rear	2	Yellow	2490	
Hose, 144	Pump to synchronizing cylinder	2	Green	2467	mounts to bracket on structure
Hose w90, 168	Sync cylinder to front slide, Room 1	2	Green	2469	103 / Drivers side
Hose w90, 168	Sync cylinder to rear slide, Room 1	2	Green	2469	196 / Drivers side
	Pump to Room 1	N/A	Green		
Hose w90, 432	Pump to Room 2	2	Purple	2486	373 / Drivers Side
Hose, 480	Pump to Room 3	2	Gray	2490	352 / Passenger Side
Hose w90, 228	Pump to Room 4	2	Red	2474	153 / Passenger Side
Hose, 60	Pump to Generator Slide	2	Blue	2460	Inside generator tray
Travel Clamp	(two per slide, except the bed slide)	6		HWH	N/A

Measuring from inside of firewall, this is the end location of the hydraulic hoses where they attach to the slide mechanism.

Options

Item, Length	Description / Location	Qty	Color	Vendor PN	

Revisions

Rev	Description

**40F Mandalay
EQUALIZER JACKS (FULLY AUTOMATIC)
STANDARD ON THIS UNIT**

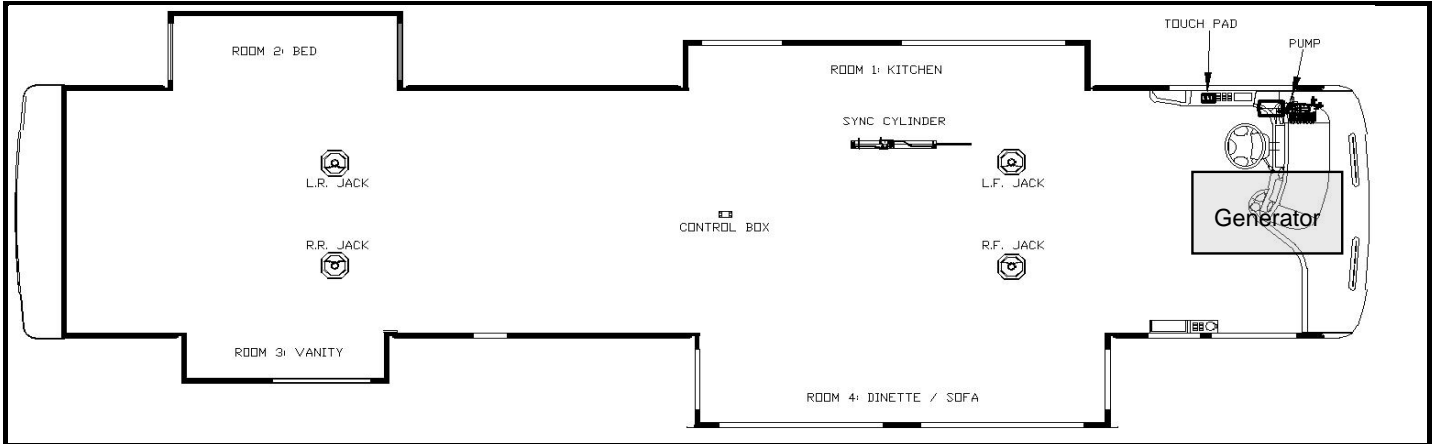

- Notes:**
- 1) Jacks mount to chassis brackets providing 8-9 inches of ground clearance with the air bags dumped.
 - 2) Level sensor attaches to bottom of structure; on lower hat section flanges or square tube.
 - 3) Hydraulic hose terminations for room #1, #3, & #4 require 90 degree swivel elbows.
 - 4) Hoses marked w90 will have the 90 deg. Fitting shipped loose

Item, Length	Description / Location	Qty	Color	Vendor PN		
Kit	(Items listed below)	1		8278		
Pump	9-Function, 4 Rooms, & Jacks	1		7302		
Jack	17,000 lbs, 18" Stroke	4		7134		
Touch Pad	Located to the left of the drivers seat	1		2318		
Control Box	Attached to bottom of structure	1		2319		
Sync Cylinder	Mounted behind LP tank	1		7387		
Hose, 144	Pump to Jack, Left Front	2	Brown	2467	Measuring from inside of firewall, this is the end location of the hydraulic hoses where they attach to the slide mechanism.	
Hose, 480	Pump to Jack, Left Rear	2	Orange	2490		
Hose, 144	Pump to Jack, Right Front	2	White	2467		
Hose, 480	Pump to Jack, Right Rear	2	Yellow	2490		
Hose, 144	Pump to synchronizing cylinder	2	Green	2467		mounts to bracket on structure
Hose w90, 168	Sync cylinder to front slide, Room 4	1	Green	2469		103 / Passenger side
Hose w90, 168	Sync cylinder to rear slide, Room 4	1	Green	2469		196 / Passenger side
Hose w90, 168	Pump to Room 1	2	Green	2469		151 / Driver Side
Hose, 480	Pump to Room 2	2	Purple	2490		353 / Drivers Side
Hose w90, 432	Pump to Room 3	2	Gray	2486		386 / Passenger Side
	Pump to Room 4	N/A	Red			
Hose, 60	Pump to Generator Slide	2			Inside generator tray	
Travel Clamp	(two per slide, except the bed slide)	6		HWH	N/A	

Options					

Revisions					

**40G Mandalay
EQUALIZER JACKS (FULLY AUTOMATIC)
STANDARD ON THIS UNIT**

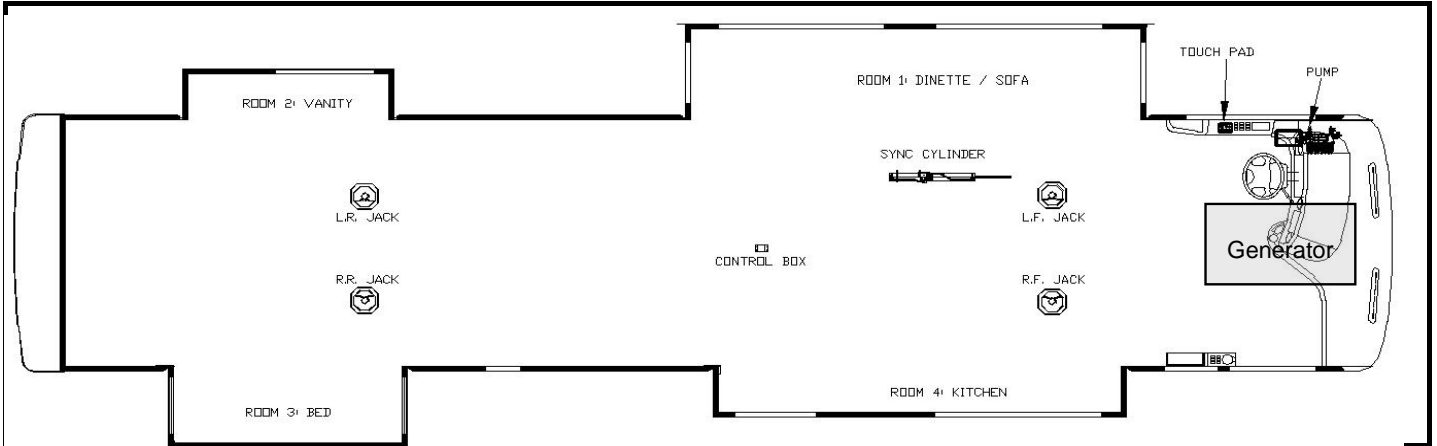

Notes:

- 1) Jacks mount to chassis brackets providing 8-9 inches of ground clearance with the air bags dumped.
- 2) Level sensor attaches to bottom of structure; on lower hat section flanges or square tube.
- 3) Hydraulic hose terminations for room #1, #3, & #4 require 90 degree swivel elbows.
- 4) Hoses marked w90 will have the 90 deg. Fitting shipped loose

Item, Length	Description / Location	Qty	Color	Vendor PN	
Kit	(Items listed below)	1		8359	
Pump	9-Function, 4 Rooms, & Jacks	1		7464BR	Measuring from inside of firewall, this is the end location of the hydraulic hoses where they attach to the slide mechanism.
Jack	17,000 lbs, 18" Stroke	4		7134	
Touch Pad	Located to the left of the drivers seat	1		2318	
Control Box	Attached to bottom of structure	1		2730	
Sync Cylinder	Mounted behind LP tank	1		7387	
Hose, 144	Pump to Jack, Left Front	2	Brown	2467	
Hose, 480	Pump to Jack, Left Rear	2	Orange	2490	
Hose, 144	Pump to Jack, Right Front	2	White	2467	
Hose, 480	Pump to Jack, Right Rear	2	Yellow	2490	
Hose, 144	Pump to synchronizing cylinder	2	Green	2467	
Hose w90, 168	Sync cylinder to front slide, Room 1	2	Green	2469	99 / Drivers side
Hose w90, 168	Sync cylinder to rear slide, Room 1	2	Green	2469	201 / Drivers side
	Pump to Room 1	N/A	Green		
Hose w90, 432	Pump to Room 2	2	Purple	2486	373 / Drivers Side
Hose, 480	Pump to Room 3	2	Gray	2490	352 / Passenger Side
Hose w90, 228	Pump to Room 4	2	Red	2474	153 / Passenger Side
Hose, 60	Pump to Generator Slide	2	Blue	2460	Inside generator tray
Travel Clamp	(two per slide, except the bed slide)	6		HWH	N/A

Options

Revisions

**40H Mandalay
EQUALIZER JACKS (FULLY AUTOMATIC)
STANDARD ON THIS UNIT**

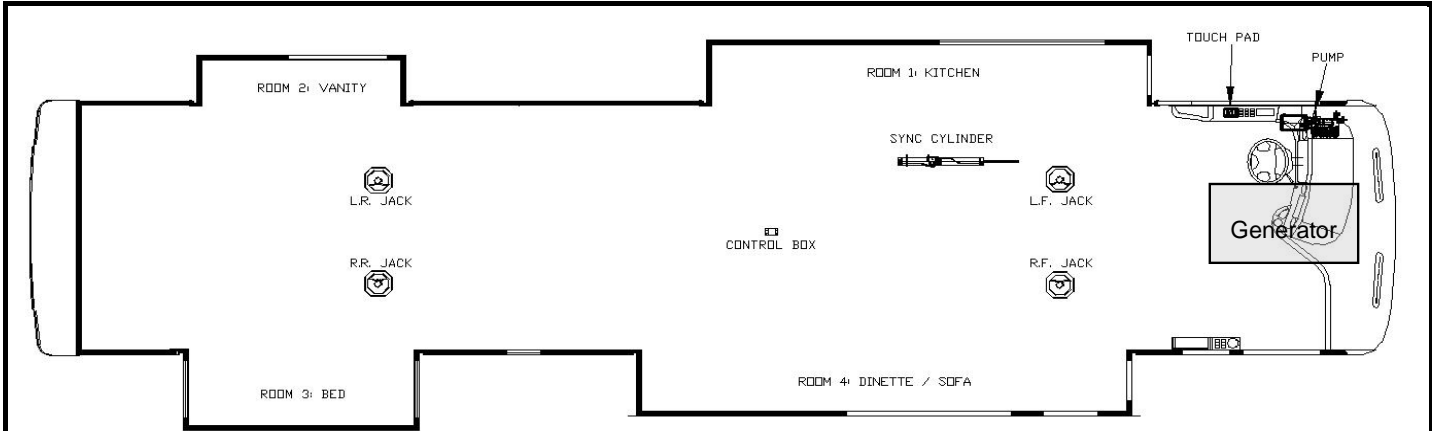

Notes:

- 1) Jacks mount to chassis brackets providing 8-9 inches of ground clearance with the air bags dumped.
- 2) Level sensor attaches to bottom of structure; on lower hat section flanges or square tube.
- 3) Hydraulic hose terminations for room #1, #3, & #4 require 90 degree swivel elbows.
- 4) Hoses marked w90 will have the 90 deg. Fitting shipped loose

Item, Length	Description / Location	Qty	Color	Vendor PN	
Kit	(Items listed below)	1		8357	
Pump	9-Function, 4 Rooms, & Jacks	1		7464BR	
Jack	17,000 lbs, 18" Stroke	4		7134	
Touch Pad	Located to the left of the drivers seat	1		2318	
Control Box	Attached to bottom of structure	1		2730	
Sync Cylinder	Mounted behind LP tank	2		7397	
Hose, 144	Pump to Jack, Left Front	2	Brown	2467	
Hose, 480	Pump to Jack, Left Rear	2	Orange	2490	
Hose, 144	Pump to Jack, Right Front	2	White	2467	
Hose, 480	Pump to Jack, Right Rear	2	Yellow	2490	
Hose, 144	Pump to synchronizing cylinder	2	Green	2467	Mounts to bracket on structure
Hose, 144	Pump to synchronizing cylinder	2	Red	2467	Mounts to bracket on structure
Hose, 480	Pump to Room 2	2	Purple	2490	325 / Drivers Side
Hose w90, 432	Pump to Room 3	2	Gray	2486	355 / Passenger Side
Hose w90, 168	Sync cylinder to front slide, Room 1	2	Green	2469	95 / Drivers Side
Hose w90, 168	Sync cylinder to rear slide, Room 1	2	Green	2469	180 / Drivers Side
Hose w90, 168	Sync cylinder to front slide, Room 4	2	Red	2469	103 / Passenger side
Hose w90, 168	Sync cylinder to rear slide, Room 4	2	Red	2469	196 / Passenger side
Hose, 60	Pump to Generator Slide	2	Blue	2460	Inside generator tray
Travel Clamp	(two per slide, except the bed slide)	6		HWH	N/A

Measuring from inside of firewall, this is the end location of the hydraulic hoses where they attach to the slide mechanism.

Options

Item, Length	Description / Location	Qty	Color	Vendor PN	

Revisions

Rev	Description

43A Mandalay
EQUALIZER JACKS (FULLY AUTOMATIC)
STANDARD ON THIS UNIT

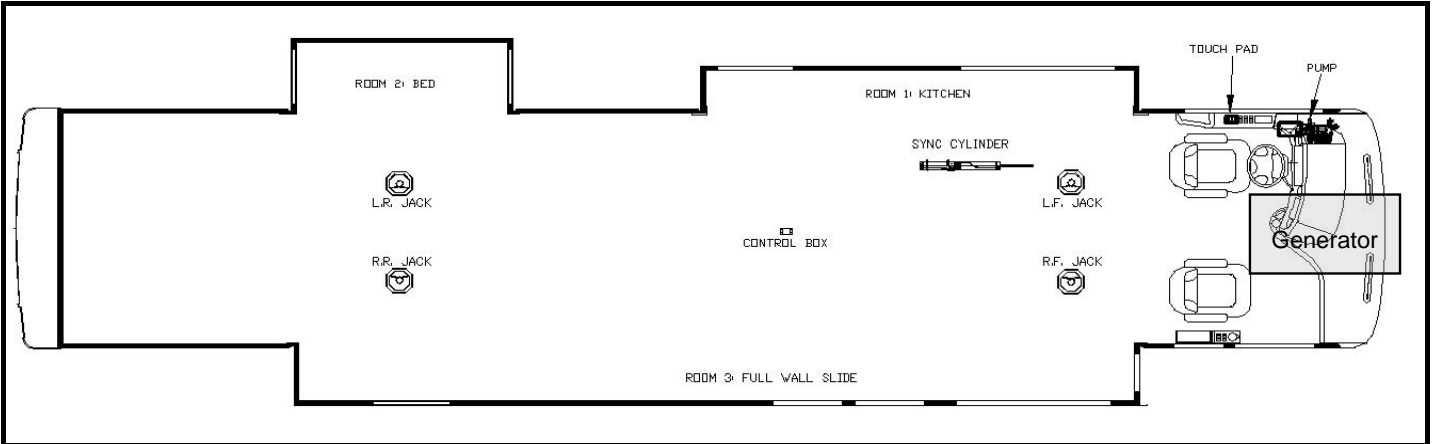

Notes:

- 1) Jacks mount to chassis brackets providing 8-9 inches of ground clearance with the air bags dumped.
- 2) Level sensor attaches to bottom of structure; on lower hat section flanges or square tube.
- 3) Hydraulic hose terminations for room #1 & #3 require 90 degree swivel elbows.
- 4) Hoses marked w90 will have the 90 deg. Fitting shipped loose
- 5) All in floor slides to have automatic travel lock sensor

Item, Length	Description / Location	Qty	Color	Vendor PN	
Kit	(Items listed below)	1		8360	
Pump	8-Function, 3 Rooms, & Jacks	1		7474BR	
Jack	17,000 lbs, 18" Stroke	4		7134	
Touch Pad	Located to the left of the drivers seat	1		2318	
Control Box	Attached to bottom of structure	1		2730	
Sync Cylinder	Mounted behind LP tank	1		7397	
Hose, 144	Pump to Jack, Left Front	2	Brown	2467	
Hose, 480	Pump to Jack, Left Rear	2	Orange	2490	
Hose, 144	Pump to Jack, Right Front	2	White	2467	
Hose, 480	Pump to Jack, Right Rear	2	Yellow	2490	
Hose, 144	Pump to synchronizing cylinder	2	Grey	2467	Mounts to bracket on structure
Hose, 216	Pump to Room 1	2	Green	2473	165 / Drivers Side
Slide Unit	Room 1 - 18" above floor slide	1		7469	
Hose w90, 516	Pump to Room 2	2	Purple	2491	408 / Drivers Side
Slide Unit	Room 2 - 30" Bed slide (Lippert)	1		143960	
Hose w90, 288	Sync cylinder to front slide, Room 3	2	Grey	2478	90 / Passenger side
Hose w90, 288	Sync cylinder to rear slide, Room 3	2	Grey	2478	378 / Passenger side
Slide Unit	Room 3 - 24" flush floor slide (angled)	2		7477	
Slide Unit	Room 3 - 24" flush floor slide (angled)	1		7384	Slave
Hose, 60	Pump to Generator Slide	2	Red	2460	Inside generator tray
Travel Clamp	(two per slide, except the bed slide)	4		HWH	N/A

Measuring from inside of firewall, this is the end location of the hydraulic hoses where they attach to the slide mechanism.

Options

Revisions

**43B Mandalay
EQUALIZER JACKS (FULLY AUTOMATIC)
STANDARD ON THIS UNIT**

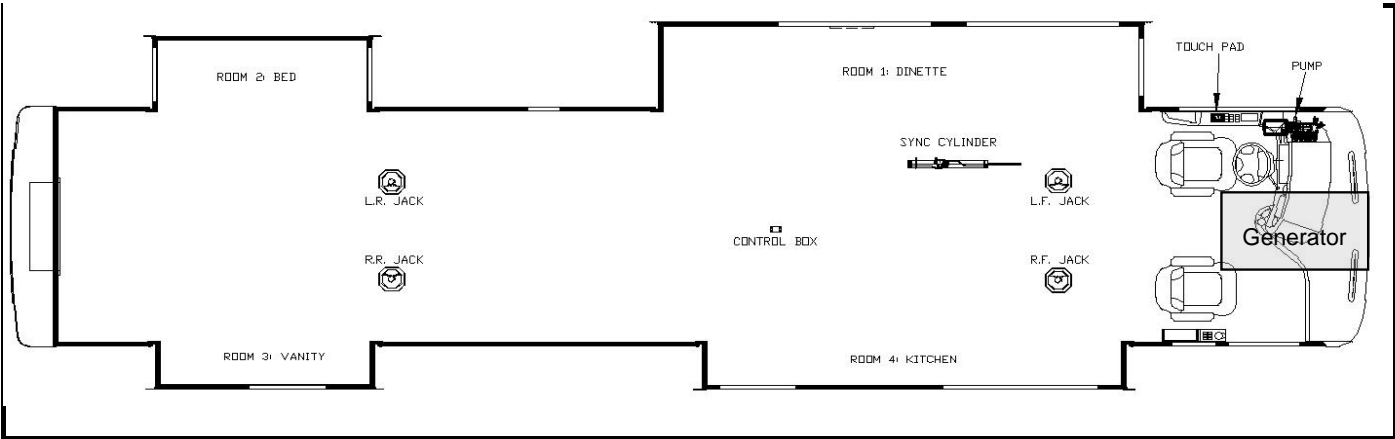

- Notes:**
- 1) Jacks mount to chassis brackets providing 8-9 inches of ground clearance with the air bags dumped.
 - 2) Level sensor attaches to bottom of structure; on lower hat section flanges or square tube.
 - 3) Hydraulic hose terminations for room #1, #3 & #4 require 90 degree swivel elbows.
 - 4) Hoses marked w90 will have the 90 deg. Fitting shipped loose
 - 5) All in floor slides to have automatic travel lock sensor

Item, Length	Description / Location	Qty	Color	Vendor PN	
Kit	(Items listed below)	1		8364	
Pump	9-Function, 4 Rooms, & Jacks	1		7464BR	
Jack	17,000 lbs, 18" Stroke	4		7134	
Touch Pad	Located to the left of the drivers seat	1		2318	
Control Box	Attached to bottom of structure	1		2730	
Sync Cylinder	Mounted behind LP tank	1		7387	
Hose, 144	Pump to Jack, Left Front	2	Brown	2467	
Hose, 480	Pump to Jack, Left Rear	2	Orange	2490	
Hose, 144	Pump to Jack, Right Front	2	White	2467	
Hose, 480	Pump to Jack, Right Rear	2	Yellow	2490	
Hose, 144	Pump to synchronizing cylinder	2	Green	2467	Mounts to bracket on structure
Hose w90, 276	Sync cylinder to front slide, Room 1	2	Green	2477	110 / Drivers Side
Hose w90, 276	Sync cylinder to rear slide, Room 1	2	Green	2477	256 / Drivers Side
Slide Unit	Room 1 - 36" flush floor slide (angled)	2		7481	
Hose, 432	Pump to Room 2	2	Purple	2486	408 / Drivers Side
Slide Unit	Room 2 - 30" Bed slide (Lippert)	1		143960	
Hose w90, 432	Pump to Room 3	2	Grey	2486	408 / Passenger side
Slide Unit	Room 3 - 18" above floor slide	1		7469	
Hose w90, 204	Pump to Room 4	2	Red	2472	164 / Passenger side
Slide Unit	Room 4 - 18" above floor slide	1		7469	
Hose, 60	Pump to Generator Slide	2	Blue	2460	Inside generator tray
Travel Clamp	(two per slide, except the bed slide)	6		HWH	N/A

Measuring from inside of firewall, this is the end location of the hydraulic hoses where they attach to the slide mechanism.

Options					

Revisions					
1					

**40E Mandalay
EQUALIZER JACKS (FULLY AUTOMATIC)
STANDARD ON THIS UNIT**

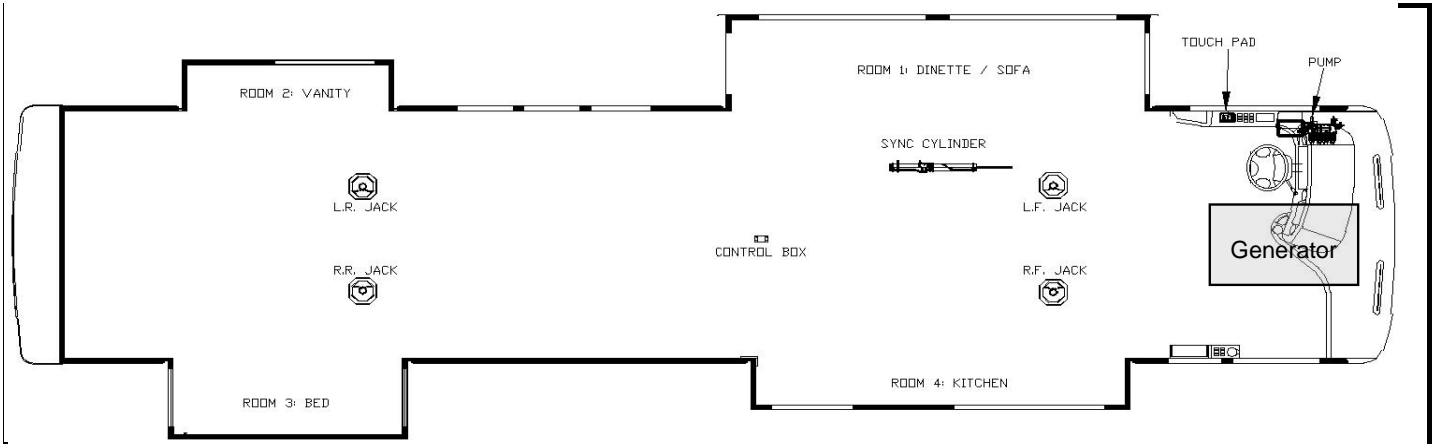

Notes:

- 1) Jacks mount to chassis brackets providing 8-9 inches of ground clearance with the air bags dumped.
- 2) Level sensor attaches to bottom of structure; on lower hat section flanges or square tube.
- 3) Hydraulic hose terminations for room #1, #2, & #4 require 90 degree swivel elbows.
- 4) Hoses marked w90 will have the 90 deg. Fitting shipped loose

Item, Length	Description / Location	Qty	Color	Vendor PN	
Kit	(Items listed below)	1		8359	
Pump	9-Function, 4 Rooms, & Jacks	1		7464BR	Measuring from inside of firewall, this is the end location of the hydraulic hoses where they attach to the slide mechanism.
Jack	17,000 lbs, 18" Stroke	4		7134	
Touch Pad	Located to the left of the drivers seat	1		2318	
Control Box	Attached to bottom of structure	1		2730	
Sync Cylinder	Mounted behind LP tank	1		7387	
Hose, 144	Pump to Jack, Left Front	2	Brown	2467	
Hose, 480	Pump to Jack, Left Rear	2	Orange	2490	
Hose, 144	Pump to Jack, Right Front	2	White	2467	
Hose, 480	Pump to Jack, Right Rear	2	Yellow	2490	
Hose, 144	Pump to synchronizing cylinder	2	Green	2467	
Hose w90, 168	Sync cylinder to front slide, Room 1	2	Green	2469	103 / Drivers side
Hose w90, 168	Sync cylinder to rear slide, Room 1	2	Green	2469	196 / Drivers side
	Pump to Room 1	N/A	Green		
Hose w90, 432	Pump to Room 2	2	Purple	2486	373 / Drivers Side
Hose, 480	Pump to Room 3	2	Gray	2490	352 / Passenger Side
Hose w90, 228	Pump to Room 4	2	Red	2474	153 / Passenger Side
Hose, 60	Pump to Generator Slide	2	Blue	2460	Inside generator tray
Travel Clamp	(two per slide, except the bed slide)	6		HWH	N/A

Options

Revisions

**40F Mandalay
EQUALIZER JACKS (FULLY AUTOMATIC)
STANDARD ON THIS UNIT**

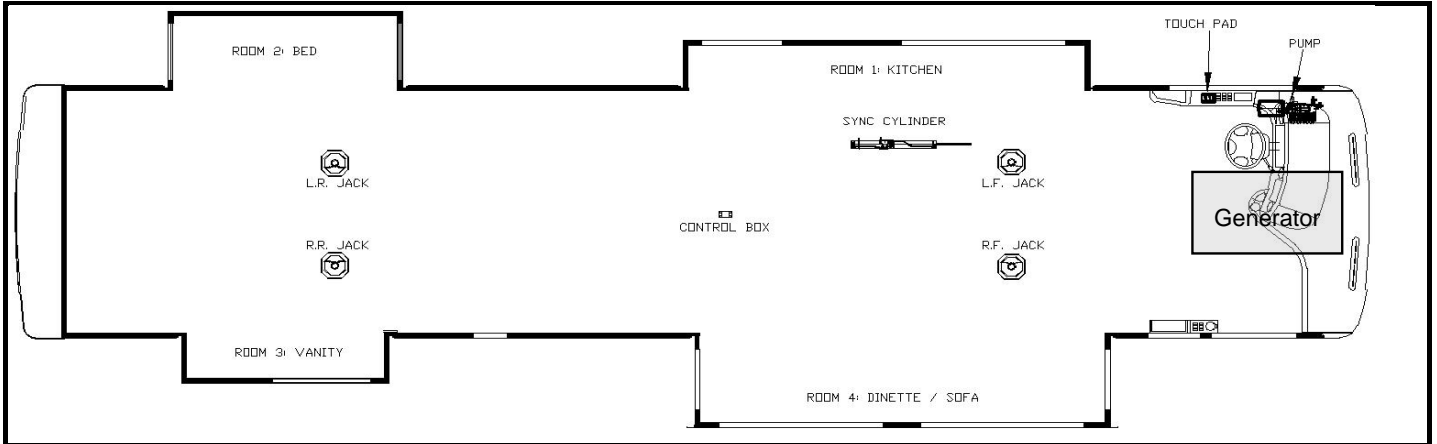

- Notes:**
- 1) Jacks mount to chassis brackets providing 8-9 inches of ground clearance with the air bags dumped.
 - 2) Level sensor attaches to bottom of structure; on lower hat section flanges or square tube.
 - 3) Hydraulic hose terminations for room #1, #3, & #4 require 90 degree swivel elbows.
 - 4) Hoses marked w90 will have the 90 deg. Fitting shipped loose

Item, Length	Description / Location	Qty	Color	Vendor PN		
Kit	(Items listed below)	1		8278		
Pump	9-Function, 4 Rooms, & Jacks	1		7302		
Jack	17,000 lbs, 18" Stroke	4		7134	Measuring from inside of firewall, this is the end location of the hydraulic hoses where they attach to the slide mechanism.	
Touch Pad	Located to the left of the drivers seat	1		2318		
Control Box	Attached to bottom of structure	1		2319		
Sync Cylinder	Mounted behind LP tank	1		7387		
Hose, 144	Pump to Jack, Left Front	2	Brown	2467		
Hose, 480	Pump to Jack, Left Rear	2	Orange	2490		
Hose, 144	Pump to Jack, Right Front	2	White	2467		
Hose, 480	Pump to Jack, Right Rear	2	Yellow	2490		
Hose, 144	Pump to synchronizing cylinder	2	Green	2467		mounts to bracket on structure
Hose w90, 168	Sync cylinder to front slide, Room 4	1	Green	2469		103 / Passenger side
Hose w90, 168	Sync cylinder to rear slide, Room 4	1	Green	2469	196 / Passenger side	
Hose w90, 168	Pump to Room 1	2	Green	2469	151 / Driver Side	
Hose, 480	Pump to Room 2	2	Purple	2490	353 / Drivers Side	
Hose w90, 432	Pump to Room 3	2	Gray	2486	386 / Passenger Side	
	Pump to Room 4	N/A	Red			
Hose, 60	Pump to Generator Slide	2			Inside generator tray	
Travel Clamp	(two per slide, except the bed slide)	6		HWH	N/A	

Options					

Revisions					

**40G Mandalay
EQUALIZER JACKS (FULLY AUTOMATIC)
STANDARD ON THIS UNIT**

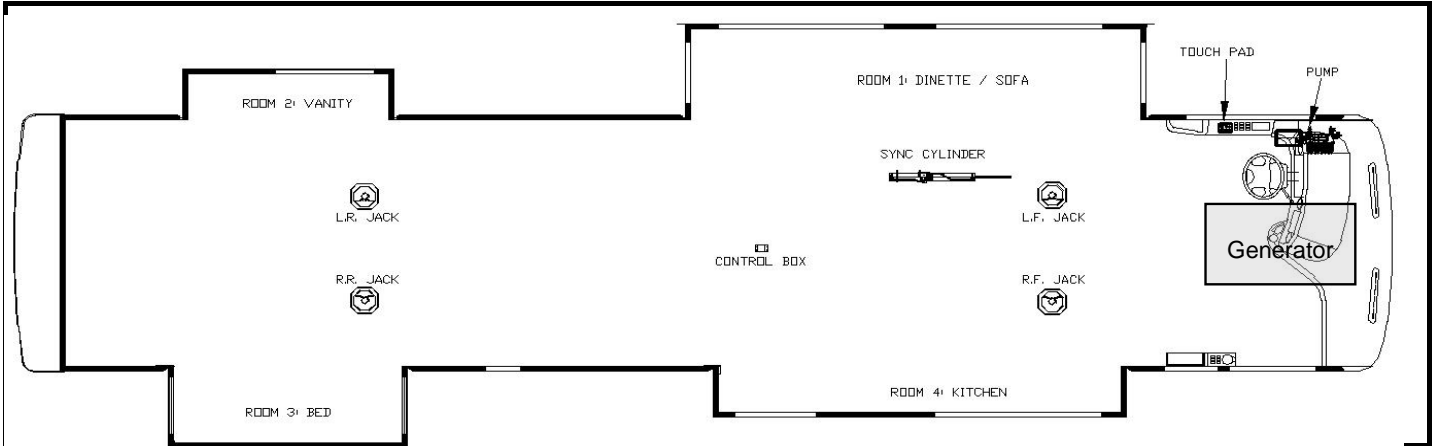

Notes:

- 1) Jacks mount to chassis brackets providing 8-9 inches of ground clearance with the air bags dumped.
- 2) Level sensor attaches to bottom of structure; on lower hat section flanges or square tube.
- 3) Hydraulic hose terminations for room #1, #3, & #4 require 90 degree swivel elbows.
- 4) Hoses marked w90 will have the 90 deg. Fitting shipped loose

Item, Length	Description / Location	Qty	Color	Vendor PN		
Kit	(Items listed below)	1		8359		
Pump	9-Function, 4 Rooms, & Jacks	1		7464BR	Measuring from inside of firewall, this is the end location of the hydraulic hoses where they attach to the slide mechanism.	
Jack	17,000 lbs, 18" Stroke	4		7134		
Touch Pad	Located to the left of the drivers seat	1		2318		
Control Box	Attached to bottom of structure	1		2730		
Sync Cylinder	Mounted behind LP tank	1		7387		
Hose, 144	Pump to Jack, Left Front	2	Brown	2467		
Hose, 480	Pump to Jack, Left Rear	2	Orange	2490		
Hose, 144	Pump to Jack, Right Front	2	White	2467		
Hose, 480	Pump to Jack, Right Rear	2	Yellow	2490		
Hose, 144	Pump to synchronizing cylinder	2	Green	2467		mounts to bracket on structure
Hose w90, 168	Sync cylinder to front slide, Room 1	2	Green	2469		99 / Drivers side
Hose w90, 168	Sync cylinder to rear slide, Room 1	2	Green	2469		201 / Drivers side
	Pump to Room 1	N/A	Green			
Hose w90, 432	Pump to Room 2	2	Purple	2486	373 / Drivers Side	
Hose, 480	Pump to Room 3	2	Gray	2490	352 / Passenger Side	
Hose w90, 228	Pump to Room 4	2	Red	2474	153 / Passenger Side	
Hose, 60	Pump to Generator Slide	2	Blue	2460	Inside generator tray	
Travel Clamp	(two per slide, except the bed slide)	6		HWH	N/A	

Options

Revisions

**40H Mandalay
EQUALIZER JACKS (FULLY AUTOMATIC)
STANDARD ON THIS UNIT**

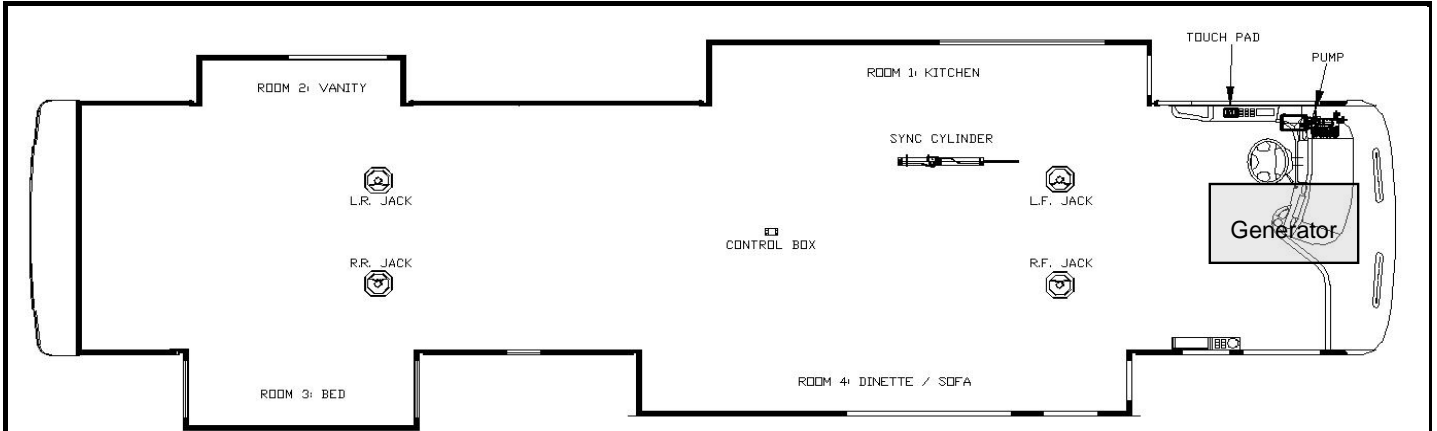

Notes:

- 1) Jacks mount to chassis brackets providing 8-9 inches of ground clearance with the air bags dumped.
- 2) Level sensor attaches to bottom of structure; on lower hat section flanges or square tube.
- 3) Hydraulic hose terminations for room #1, #3, & #4 require 90 degree swivel elbows.
- 4) Hoses marked w90 will have the 90 deg. Fitting shipped loose

Item, Length	Description / Location	Qty	Color	Vendor PN	
Kit	(Items listed below)	1		8357	
Pump	9-Function, 4 Rooms, & Jacks	1		7464BR	Measuring from inside of firewall, this is the end location of the hydraulic hoses where they attach to the slide mechanism.
Jack	17,000 lbs, 18" Stroke	4		7134	
Touch Pad	Located to the left of the drivers seat	1		2318	
Control Box	Attached to bottom of structure	1		2730	
Sync Cylinder	Mounted behind LP tank	2		7397	
Hose, 144	Pump to Jack, Left Front	2	Brown	2467	
Hose, 480	Pump to Jack, Left Rear	2	Orange	2490	
Hose, 144	Pump to Jack, Right Front	2	White	2467	
Hose, 480	Pump to Jack, Right Rear	2	Yellow	2490	
Hose, 144	Pump to synchronizing cylinder	2	Green	2467	
Hose, 144	Pump to synchronizing cylinder	2	Red	2467	Mounts to bracket on structure
Hose, 480	Pump to Room 2	2	Purple	2490	325 / Drivers Side
Hose w90, 432	Pump to Room 3	2	Gray	2486	355 / Passenger Side
Hose w90, 168	Sync cylinder to front slide, Room 1	2	Green	2469	95 / Drivers Side
Hose w90, 168	Sync cylinder to rear slide, Room 1	2	Green	2469	180 / Drivers Side
Hose w90, 168	Sync cylinder to front slide, Room 4	2	Red	2469	103 / Passenger side
Hose w90, 168	Sync cylinder to rear slide, Room 4	2	Red	2469	196 / Passenger side
Hose, 60	Pump to Generator Slide	2	Blue	2460	Inside generator tray
Travel Clamp	(two per slide, except the bed slide)	6		HWH	N/A

Options

Revisions

43A Mandalay
EQUALIZER JACKS (FULLY AUTOMATIC)
STANDARD ON THIS UNIT

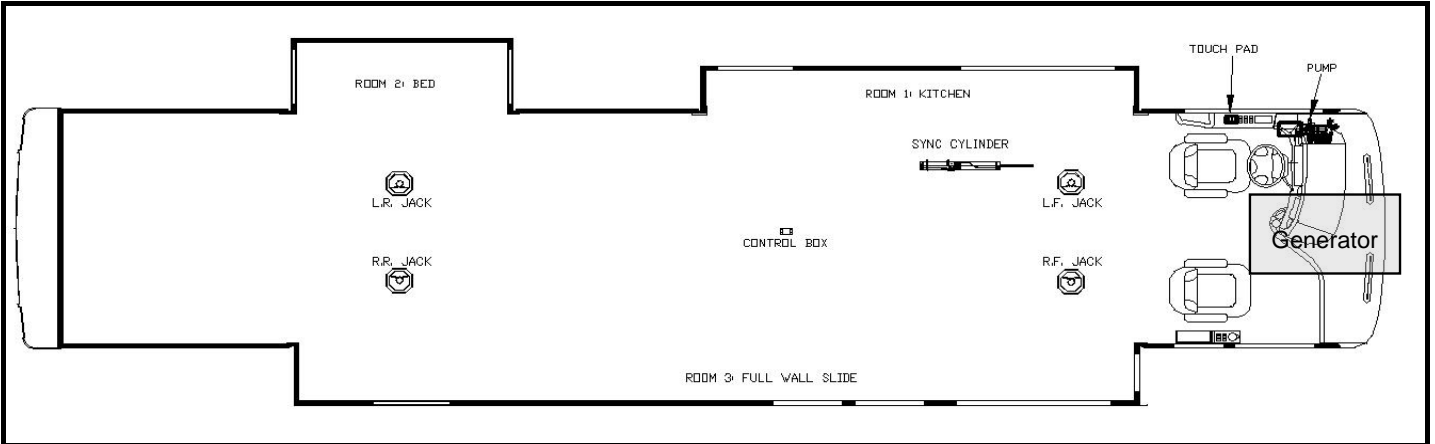

Notes:

- 1) Jacks mount to chassis brackets providing 8-9 inches of ground clearance with the air bags dumped.
- 2) Level sensor attaches to bottom of structure; on lower hat section flanges or square tube.
- 3) Hydraulic hose terminations for room #1 & #3 require 90 degree swivel elbows.
- 4) Hoses marked w90 will have the 90 deg. Fitting shipped loose
- 5) All in floor slides to have automatic travel lock sensor

Item, Length	Description / Location	Qty	Color	Vendor PN	
Kit	(Items listed below)	1		8360	
Pump	8-Function, 3 Rooms, & Jacks	1		7474BR	
Jack	17,000 lbs, 18" Stroke	4		7134	
Touch Pad	Located to the left of the drivers seat	1		2318	
Control Box	Attached to bottom of structure	1		2730	
Sync Cylinder	Mounted behind LP tank	1		7397	
Hose, 144	Pump to Jack, Left Front	2	Brown	2467	
Hose, 480	Pump to Jack, Left Rear	2	Orange	2490	
Hose, 144	Pump to Jack, Right Front	2	White	2467	
Hose, 480	Pump to Jack, Right Rear	2	Yellow	2490	
Hose, 144	Pump to synchronizing cylinder	2	Grey	2467	Mounts to bracket on structure
Hose, 216	Pump to Room 1	2	Green	2473	165 / Drivers Side
Slide Unit	Room 1 - 18" above floor slide	1		7469	
Hose w90, 516	Pump to Room 2	2	Purple	2491	408 / Drivers Side
Slide Unit	Room 2 - 30" Bed slide (Lippert)	1		134998	
Hose w90, 288	Sync cylinder to front slide, Room 3	2	Grey	2478	90 / Passenger side
Hose w90, 288	Sync cylinder to rear slide, Room 3	2	Grey	2478	378 / Passenger side
Slide Unit	Room 3 - 24" flush floor slide (angled)	2		7477	
Slide Unit	Room 3 - 24" flush floor slide (angled)	1		7384	Slave
Hose, 60	Pump to Generator Slide	2	Red	2460	Inside generator tray
Travel Clamp	(two per slide, except the bed slide)	4		HWH	N/A

Measuring from inside of firewall, this is the end location of the hydraulic hoses where they attach to the slide mechanism.

Options

Item, Length	Description / Location	Qty	Color	Vendor PN	

Revisions

Rev	Description	Date	By
1	Corrected the bed slide Vendor Part No. Was 143960.	8-15-07	JS

**43B Mandalay
EQUALIZER JACKS (FULLY AUTOMATIC)
STANDARD ON THIS UNIT**

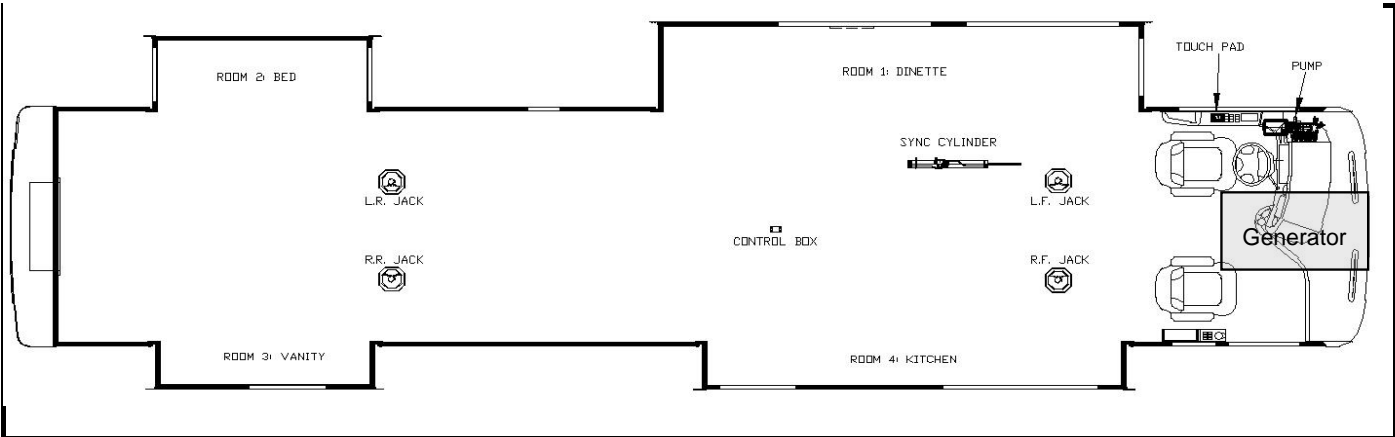

Notes:

- 1) Jacks mount to chassis brackets providing 8-9 inches of ground clearance with the air bags dumped.
- 2) Level sensor attaches to bottom of structure; on lower hat section flanges or square tube.
- 3) Hydraulic hose terminations for room #1, #3 & #4 require 90 degree swivel elbows.
- 4) Hoses marked w90 will have the 90 deg. Fitting shipped loose
- 5) All in floor slides to have automatic travel lock sensor

Item, Length	Description / Location	Qty	Color	Vendor PN	
Kit	(Items listed below)	1		8364	
Pump	9-Function, 4 Rooms, & Jacks	1		7464BR	
Jack	17,000 lbs, 18" Stroke	4		7134	
Touch Pad	Located to the left of the drivers seat	1		2318	
Control Box	Attached to bottom of structure	1		2730	
Sync Cylinder	Mounted behind LP tank	1		7387	
Hose, 144	Pump to Jack, Left Front	2	Brown	2467	
Hose, 480	Pump to Jack, Left Rear	2	Orange	2490	
Hose, 144	Pump to Jack, Right Front	2	White	2467	
Hose, 480	Pump to Jack, Right Rear	2	Yellow	2490	
Hose, 144	Pump to synchronizing cylinder	2	Green	2467	Mounts to bracket on structure
Hose w90, 216	Sync cylinder to front slide, Room 1	2	Green	2473	110 / Drivers Side
Hose w90, 216	Sync cylinder to rear slide, Room 1	2	Green	2473	256 / Drivers Side
Slide Unit	Room 1 - 36" flush floor slide (angled)	2		7481	
Hose, 480	Pump to Room 2	2	Purple	2490	408 / Drivers Side
Slide Unit	Room 2 - 30" Bed slide (Lippert)	1		134998	
Hose w90, 480	Pump to Room 3	2	Grey	2490	408 / Passenger side
Slide Unit	Room 3 - 18" above floor slide	1		7469	
Hose w90, 204	Pump to Room 4	2	Red	2472	164 / Passenger side
Slide Unit	Room 4 - 18" above floor slide	1		7469	
Hose, 60	Pump to Generator Slide	2	Blue	2460	Inside generator tray
Travel Clamp	(two per slide, except the bed slide)	6		HWH	N/A

Measuring from inside of firewall, this is the end location of the hydraulic hoses where they attach to the slide mechanism.

Options

Revisions

1	Corrected the bed slide Vendor Part No. Was 143960.	8-15-07	JS
2	Chg'd Room 1 Sync cylinder hose lengths from 276" (PN 2477) to 216" (PN 2473).	8-31-07	KK

43C Mandalay
EQUALIZER JACKS (FULLY AUTOMATIC)
STANDARD ON THIS UNIT

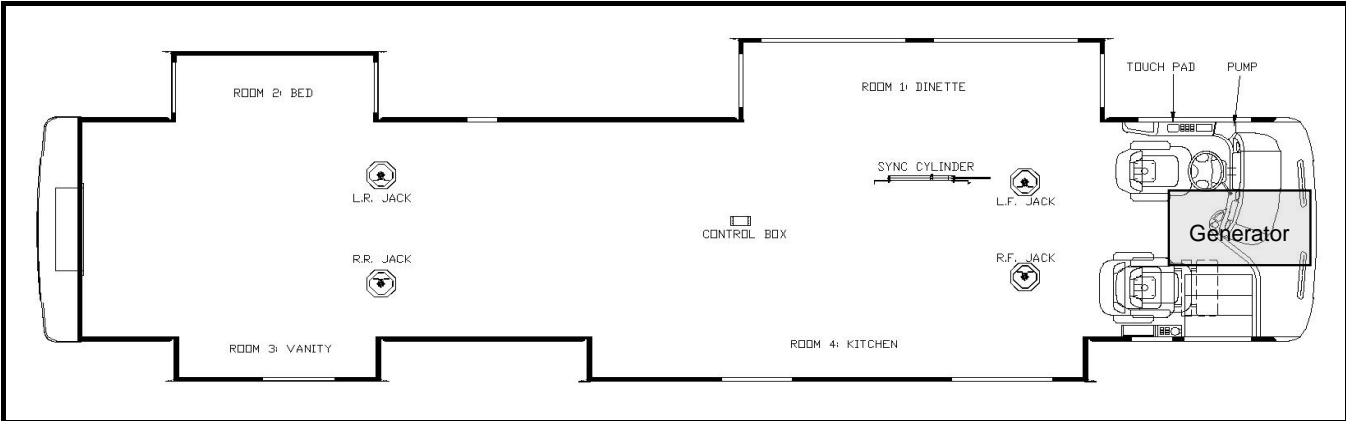

- Notes:**
- 1) Jacks mount to chassis brackets providing 8-9 inches of ground clearance with the air bags dumped.
 - 2) Level sensor attaches to bottom of structure; on lower hat section flanges or square tube.
 - 3) Hydraulic hose terminations for room #1, #3 & #4 require 90 degree swivel elbows.
 - 4) Hoses marked w90 will have the 90 deg. Fitting shipped loose
 - 5) All in floor slides to have automatic travel lock sensor

Item, Length	Description / Location	Qty	Color	Vendor PN	
Kit	(Items listed below)	1		8377	
Pump	9-Function, 4 Rooms, & Jacks	1		7464BR	
Jack	17,000 lbs, 18" Stroke	4		7134	
Touch Pad	Located to the left of the drivers seat	1		2318	
Control Box	Attached to bottom of structure	1		2730	
Sync Cylinder	Mounted behind LP tank, Room 1	1		7387	
Sync Cylinder	Mounted behind LP tank, Room 4	1		7511	
Hose, 144	Pump to Jack, Left Front	2	Brown	2467	
Hose, 480	Pump to Jack, Left Rear	2	Orange	2490	
Hose, 144	Pump to Jack, Right Front	2	White	2467	
Hose, 480	Pump to Jack, Right Rear	2	Yellow	2490	
Hose, 180	Pump to synchronizing cylinder	2	Green	2470	Mounts to bracket on structure
Hose w90, 168	Sync cylinder to front slide, Room 1	2	Green	2469	99 / Drivers Side
Hose w90, 168	Sync cylinder to rear slide, Room 1	2	Green	2469	187 / Drivers Side
Slide Unit	Room 1 - 36" flush floor slide (angled)	2		7481	
Hose, 432	Pump to Room 2	2	Purple	2486	408 / Drivers Side
Slide Unit	Room 2 - 30" Bed slide (Lippert)	1		134998	
Hose w90, 432	Pump to Room 3	2	Grey	2486	408 / Passenger side
Slide Unit	Room 3 - 18" above floor slide	1		7469	
Hose, 180	Pump to synchronizing cylinder	2	Red	2470	Mounts to bracket on structure
Hose w90, 228	Sync cylinder to front slide, Room 4	2	Red	2474	135 / Passenger Side
Hose w90, 228	Sync cylinder to rear slide, Room 4	2	Red	2474	220 / Passenger Side
Slide Unit	Room 4 - 18" above floor slide	2		7469	
Hose, 60	Pump to Generator Slide	2	Blue	2460	Inside generator tray
Travel Clamp	(two per slide, except the bed slide)	6		HWH	N/A

Measuring from inside of firewall, this is the end location of the hydraulic hoses where they attach to the slide mechanism.

Options

Revisions

**40E Mandalay
EQUALIZER JACKS (FULLY AUTOMATIC)
STANDARD ON THIS UNIT**

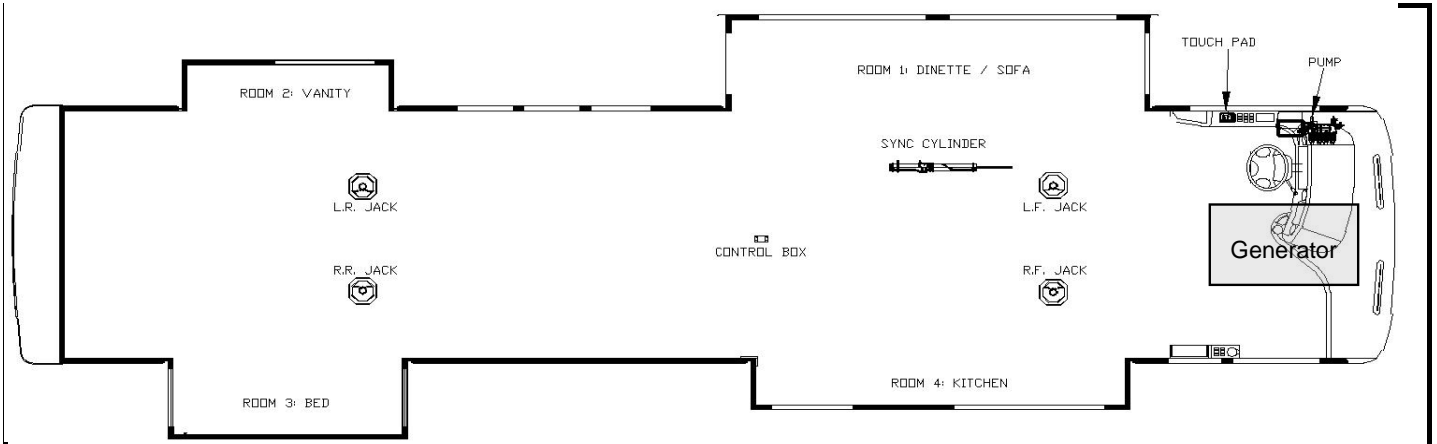

Notes:

- 1) Jacks mount to chassis brackets providing 8-9 inches of ground clearance with the air bags dumped.
- 2) Level sensor attaches to bottom of structure; on lower hat section flanges or square tube.
- 3) Hydraulic hose terminations for room #1, #2, & #4 require 90 degree swivel elbows.
- 4) Hoses marked w90 will have the 90 deg. Fitting shipped loose

Item, Length	Description / Location	Qty	Color	Vendor PN	
Kit	(Items listed below)	1		8359	
Pump	9-Function, 4 Rooms, & Jacks	1		7464BR	Measuring from inside of firewall, this is the end location of the hydraulic hoses where they attach to the slide mechanism.
Jack	17,000 lbs, 18" Stroke	4		7134	
Touch Pad	Located to the left of the drivers seat	1		2318	
Control Box	Attached to bottom of structure	1		2730	
Sync Cylinder	Mounted behind LP tank	1		7387	
Hose, 144	Pump to Jack, Left Front	2	Brown	2467	
Hose, 480	Pump to Jack, Left Rear	2	Orange	2490	
Hose, 144	Pump to Jack, Right Front	2	White	2467	
Hose, 480	Pump to Jack, Right Rear	2	Yellow	2490	
Hose, 144	Pump to synchronizing cylinder	2	Green	2467	
Hose w90, 168	Sync cylinder to front slide, Room 1	2	Green	2469	103 / Drivers side
Hose w90, 168	Sync cylinder to rear slide, Room 1	2	Green	2469	196 / Drivers side
	Pump to Room 1	N/A	Green		
Hose w90, 432	Pump to Room 2	2	Purple	2486	373 / Drivers Side
Hose, 480	Pump to Room 3	2	Gray	2490	352 / Passenger Side
Hose w90, 228	Pump to Room 4	2	Red	2474	153 / Passenger Side
Hose, 60	Pump to Generator Slide	2	Blue	2460	Inside generator tray
Travel Clamp	(two per slide, except the bed slide)	6		HWH	N/A

Options

Revisions

**40F Mandalay
EQUALIZER JACKS (FULLY AUTOMATIC)
STANDARD ON THIS UNIT**

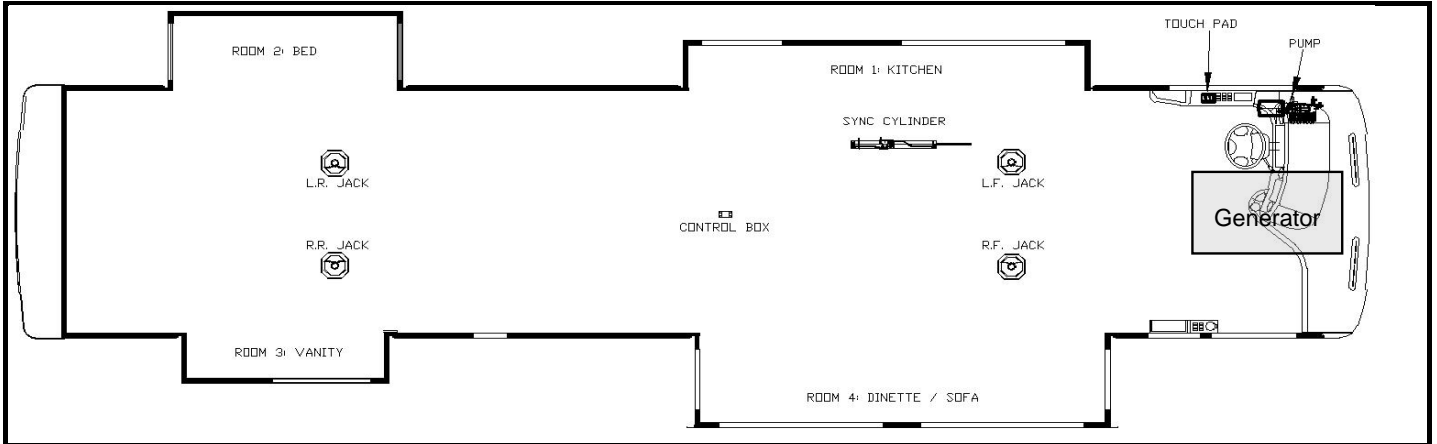

- Notes:**
- 1) Jacks mount to chassis brackets providing 8-9 inches of ground clearance with the air bags dumped.
 - 2) Level sensor attaches to bottom of structure; on lower hat section flanges or square tube.
 - 3) Hydraulic hose terminations for room #1, #3, & #4 require 90 degree swivel elbows.
 - 4) Hoses marked w90 will have the 90 deg. Fitting shipped loose

Item, Length	Description / Location	Qty	Color	Vendor PN	
Kit	(Items listed below)	1		8278	
Pump	9-Function, 4 Rooms, & Jacks	1		7302	
Jack	17,000 lbs, 18" Stroke	4		7134	
Touch Pad	Located to the left of the drivers seat	1		2318	
Control Box	Attached to bottom of structure	1		2319	
Sync Cylinder	Mounted behind LP tank	1		7387	
Hose, 144	Pump to Jack, Left Front	2	Brown	2467	
Hose, 480	Pump to Jack, Left Rear	2	Orange	2490	
Hose, 144	Pump to Jack, Right Front	2	White	2467	
Hose, 480	Pump to Jack, Right Rear	2	Yellow	2490	
Hose, 144	Pump to synchronizing cylinder	2	Green	2467	mounts to bracket on structure
Hose w90, 168	Sync cylinder to front slide, Room 4	1	Green	2469	103 / Passenger side
Hose w90, 168	Sync cylinder to rear slide, Room 4	1	Green	2469	196 / Passenger side
Hose w90, 168	Pump to Room 1	2	Green	2469	151 / Driver Side
Hose, 480	Pump to Room 2	2	Purple	2490	353 / Drivers Side
Hose w90, 432	Pump to Room 3	2	Gray	2486	386 / Passenger Side
	Pump to Room 4	N/A	Red		
Hose, 60	Pump to Generator Slide	2			Inside generator tray
Travel Clamp	(two per slide, except the bed slide)	6		HWH	N/A

Measuring from inside of firewall, this is the end location of the hydraulic hoses where they attach to the slide mechanism.

Options					

Revisions					

**40G Mandalay
EQUALIZER JACKS (FULLY AUTOMATIC)
STANDARD ON THIS UNIT**

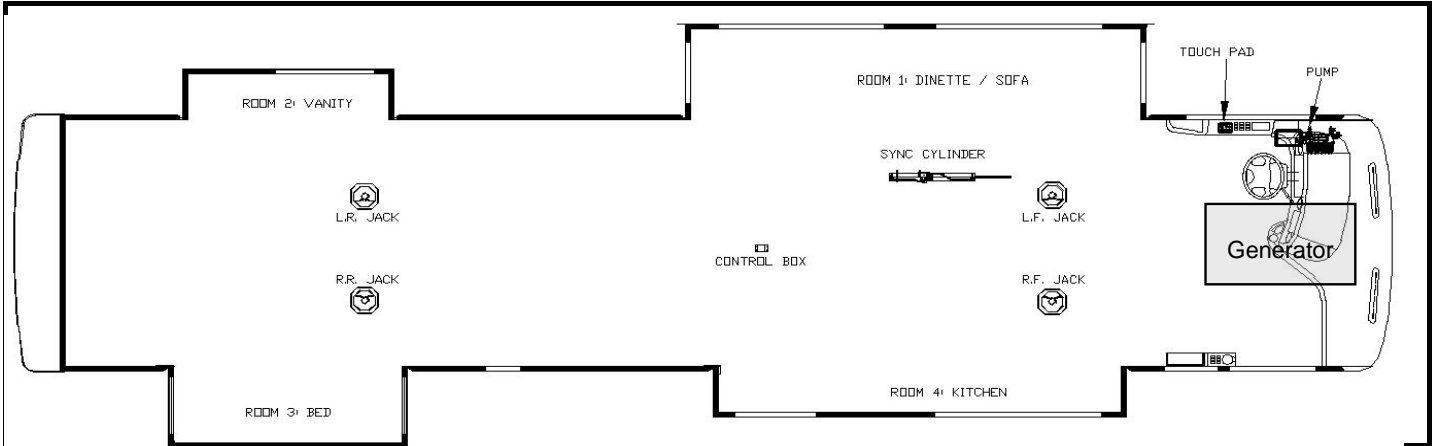

Notes:

- 1) Jacks mount to chassis brackets providing 8-9 inches of ground clearance with the air bags dumped.
- 2) Level sensor attaches to bottom of structure; on lower hat section flanges or square tube.
- 3) Hydraulic hose terminations for room #1, #3, & #4 require 90 degree swivel elbows.
- 4) Hoses marked w90 will have the 90 deg. Fitting shipped loose

Item, Length	Description / Location	Qty	Color	Vendor PN	
Kit	(Items listed below)	1		8359	
Pump	9-Function, 4 Rooms, & Jacks	1		7464BR	Measuring from inside of firewall, this is the end location of the hydraulic hoses where they attach to the slide mechanism.
Jack	17,000 lbs, 18" Stroke	4		7134	
Touch Pad	Located to the left of the drivers seat	1		2318	
Control Box	Attached to bottom of structure	1		2730	
Sync Cylinder	Mounted behind LP tank	1		7387	
Hose, 144	Pump to Jack, Left Front	2	Brown	2467	
Hose, 480	Pump to Jack, Left Rear	2	Orange	2490	
Hose, 144	Pump to Jack, Right Front	2	White	2467	
Hose, 480	Pump to Jack, Right Rear	2	Yellow	2490	
Hose, 144	Pump to synchronizing cylinder	2	Green	2467	
Hose w90, 168	Sync cylinder to front slide, Room 1	2	Green	2469	99 / Drivers side
Hose w90, 168	Sync cylinder to rear slide, Room 1	2	Green	2469	201 / Drivers side
	Pump to Room 1	N/A	Green		
Hose w90, 432	Pump to Room 2	2	Purple	2486	373 / Drivers Side
Hose, 480	Pump to Room 3	2	Gray	2490	352 / Passenger Side
Hose w90, 228	Pump to Room 4	2	Red	2474	153 / Passenger Side
Hose, 60	Pump to Generator Slide	2	Blue	2460	Inside generator tray
Travel Clamp	(two per slide, except the bed slide)	6		HWH	N/A

Options

Revisions

**40H Mandalay
EQUALIZER JACKS (FULLY AUTOMATIC)
STANDARD ON THIS UNIT**

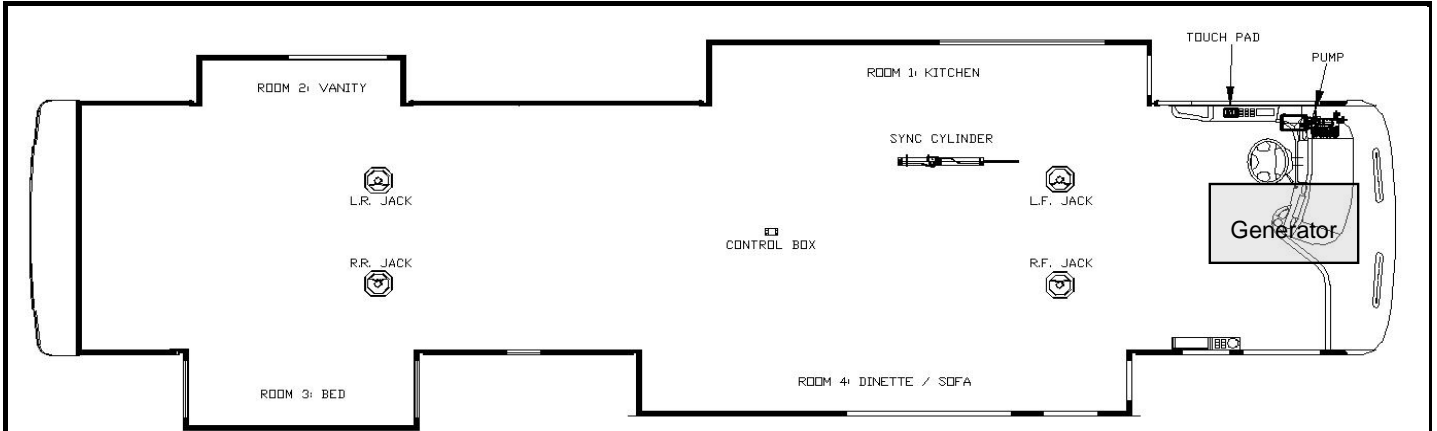

Notes:

- 1) Jacks mount to chassis brackets providing 8-9 inches of ground clearance with the air bags dumped.
- 2) Level sensor attaches to bottom of structure; on lower hat section flanges or square tube.
- 3) Hydraulic hose terminations for room #1, #3, & #4 require 90 degree swivel elbows.
- 4) Hoses marked w90 will have the 90 deg. Fitting shipped loose

Item, Length	Description / Location	Qty	Color	Vendor PN	
Kit	(Items listed below)	1		8357	
Pump	9-Function, 4 Rooms, & Jacks	1		7464BR	
Jack	17,000 lbs, 18" Stroke	4		7134	
Touch Pad	Located to the left of the drivers seat	1		2318	
Control Box	Attached to bottom of structure	1		2730	
Sync Cylinder	Mounted behind LP tank	2		7397	
Hose, 144	Pump to Jack, Left Front	2	Brown	2467	
Hose, 480	Pump to Jack, Left Rear	2	Orange	2490	
Hose, 144	Pump to Jack, Right Front	2	White	2467	
Hose, 480	Pump to Jack, Right Rear	2	Yellow	2490	
Hose, 144	Pump to synchronizing cylinder	2	Green	2467	Mounts to bracket on structure
Hose, 144	Pump to synchronizing cylinder	2	Red	2467	Mounts to bracket on structure
Hose, 480	Pump to Room 2	2	Purple	2490	325 / Drivers Side
Slide Unit	Room 2-18" above floor slide)	1		7469	
Hose w90, 432	Pump to Room 3	2	Gray	2486	355 / Passenger Side
Slide Unit	Room 3-30" Bed slide (Lippert)	1		134998	
Hose w90, 168	Sync cylinder to front slide, Room 1	2	Green	2469	95 / Drivers Side
Hose w90, 168	Sync cylinder to rear slide, Room 1	2	Green	2469	180 / Drivers Side
Slide Unit	Room 1-24" flush floor slide (angled)	2		7477	
Hose w90, 168	Sync cylinder to front slide, Room 4	2	Red	2469	103 / Passenger side
Hose w90, 168	Sync cylinder to rear slide, Room 4	2	Red	2469	196 / Passenger side
Slide Unit	Room 4-24" flush floor slide (angled)	2		7477	
Hose, 60	Pump to Generator Slide	2	Blue	2460	Inside generator tray
Travel Clamp	(two per slide, except the bed slide)	6		HWH	N/A

Measuring from inside of firewall, this is the end location of the hydraulic hoses where they attach to the slide mechanism.

Options

Revisions

43A Mandalay
EQUALIZER JACKS (FULLY AUTOMATIC)
STANDARD ON THIS UNIT

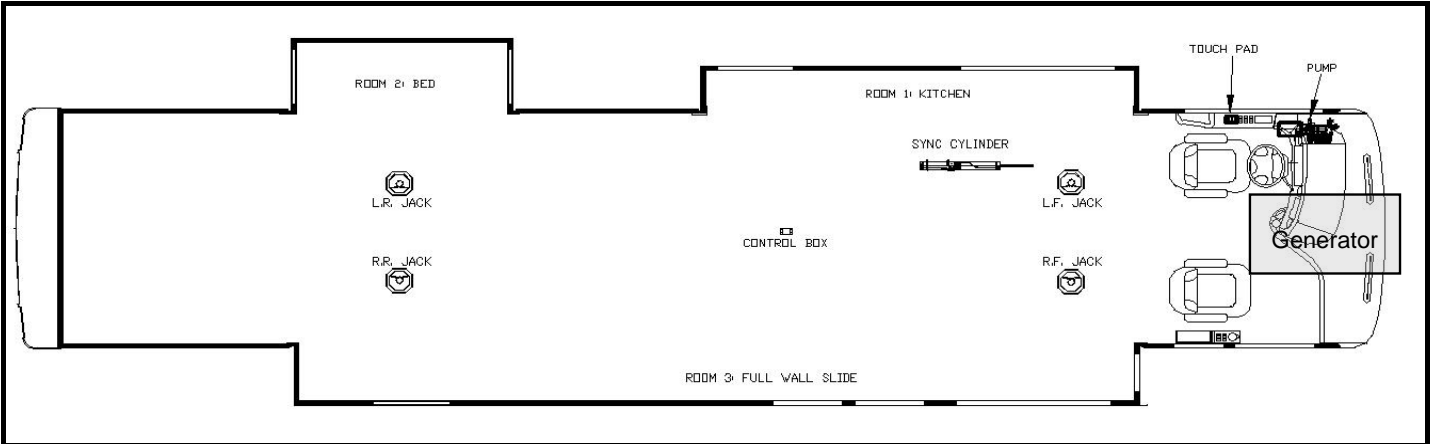

Notes:

- 1) Jacks mount to chassis brackets providing 8-9 inches of ground clearance with the air bags dumped.
- 2) Level sensor attaches to bottom of structure; on lower hat section flanges or square tube.
- 3) Hydraulic hose terminations for room #1 & #3 require 90 degree swivel elbows.
- 4) Hoses marked w90 will have the 90 deg. Fitting shipped loose
- 5) All in floor slides to have automatic travel lock sensor

Item, Length	Description / Location	Qty	Color	Vendor PN	
Kit	(Items listed below)	1		8360	
Pump	8-Function, 3 Rooms, & Jacks	1		7474BR	Measuring from inside of firewall, this is the end location of the hydraulic hoses where they attach to the slide mechanism.
Jack	17,000 lbs, 18" Stroke	4		7134	
Touch Pad	Located to the left of the drivers seat	1		2318	
Control Box	Attached to bottom of structure	1		2730	
Sync Cylinder	Mounted behind LP tank	1		7397	
Hose, 144	Pump to Jack, Left Front	2	Brown	2467	
Hose, 480	Pump to Jack, Left Rear	2	Orange	2490	
Hose, 144	Pump to Jack, Right Front	2	White	2467	
Hose, 480	Pump to Jack, Right Rear	2	Yellow	2490	
Hose, 144	Pump to synchronizing cylinder	2	Grey	2467	
Hose, 216	Pump to Room 1	2	Green	2473	165 / Drivers Side
Slide Unit	Room 1 - 18" above floor slide	1		7469	
Hose w90, 516	Pump to Room 2	2	Purple	2491	408 / Drivers Side
Slide Unit	Room 2 - 30" Bed slide (Lippert)	1		134998	
Hose w90, 288	Sync cylinder to front slide, Room 3	2	Grey	2478	90 / Passenger side
Hose w90, 288	Sync cylinder to rear slide, Room 3	2	Grey	2478	378 / Passenger side
Slide Unit	Room 3 - 24" flush floor slide (angled)	2		7477	
Slide Unit	Room 3 - 24" flush floor slide (angled)	1		7384	Slave
Hose, 60	Pump to Generator Slide	2	Red	2460	Inside generator tray
Travel Clamp	(two per slide, except the bed slide)	4		HWH	N/A

Options

Item, Length	Description / Location	Qty	Color	Vendor PN	

Revisions

Rev	Description	Date	By
1	Corrected the bed slide Vendor Part No. Was 143960.	8-15-07	JS

**43B Mandalay
EQUALIZER JACKS (FULLY AUTOMATIC)
STANDARD ON THIS UNIT**

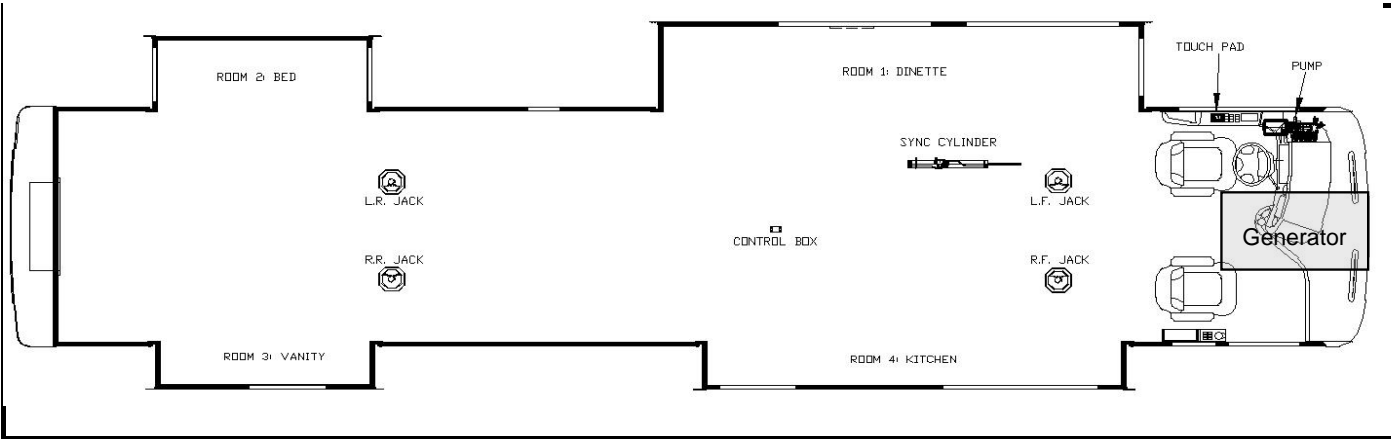

- Notes:**
- 1) Jacks mount to chassis brackets providing 8-9 inches of ground clearance with the air bags dumped.
 - 2) Level sensor attaches to bottom of structure; on lower hat section flanges or square tube.
 - 3) Hydraulic hose terminations for room #1, #3 & #4 require 90 degree swivel elbows.
 - 4) Hoses marked w90 will have the 90 deg. Fitting shipped loose
 - 5) All in floor slides to have automatic travel lock sensor

Item, Length	Description / Location	Qty	Color	Vendor PN		
Kit	(Items listed below)	1		8364	<p align="center">Measuring from inside of firewall, this is the end location of the hydraulic hoses where they attach to the slide mechanism.</p>	
Pump	9-Function, 4 Rooms, & Jacks	1		7464BR		
Jack	17,000 lbs, 18" Stroke	4		7134		
Touch Pad	Located to the left of the drivers seat	1		2318		
Control Box	Attached to bottom of structure	1		2730		
Sync Cylinder	Mounted behind LP tank	1		7387		
Hose, 144	Pump to Jack, Left Front	2	Brown	2467		
Hose, 480	Pump to Jack, Left Rear	2	Orange	2490		
Hose, 144	Pump to Jack, Right Front	2	White	2467		
Hose, 480	Pump to Jack, Right Rear	2	Yellow	2490		
Hose, 144	Pump to synchronizing cylinder	2	Green	2467		Mounts to bracket on structure
Hose w90, 216	Sync cylinder to front slide, Room 1	2	Green	2473		110 / Drivers Side
Hose w90, 216	Sync cylinder to rear slide, Room 1	2	Green	2473		256 / Drivers Side
Slide Unit	Room 1 - 36" flush floor slide (angled)	2		7481		
Hose, 516	Pump to Room 2	2	Purple	2491		408 / Drivers Side
Slide Unit	Room 2 - 30" Bed slide (Lippert)	1		134998		
Hose w90, 480	Pump to Room 3	2	Grey	2490		408 / Passenger side
Slide Unit	Room 3 - 18" above floor slide	1		7469		
Hose w90, 204	Pump to Room 4	2	Red	2472		164 / Passenger side
Slide Unit	Room 4 - 18" above floor slide	1		7469		
Hose, 60	Pump to Generator Slide	2	Blue	2460	Inside generator tray	
Travel Clamp	(two per slide, except the bed slide)	6		HWH	N/A	

Options					

Revisions					
1	Corrected the bed slide Vendor Part No. Was 143960.	8-15-07	JS		
2	Chg'd Room 1 Sync cylinder hose lengths from 276" (PN 2477) to 216" (PN 2473).	8-31-07	KK		

**43C Mandalay
EQUALIZER JACKS (FULLY AUTOMATIC)
STANDARD ON THIS UNIT**

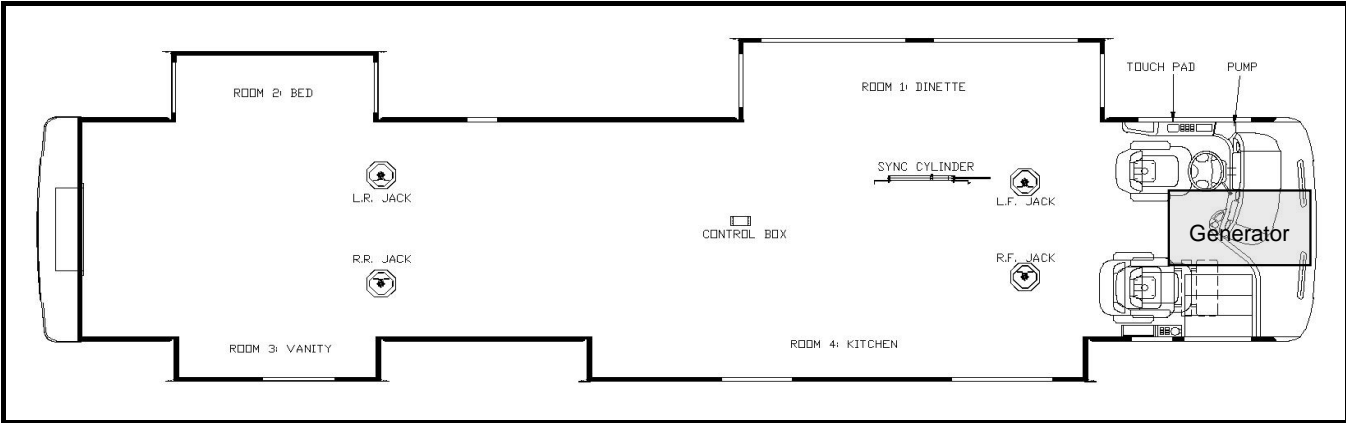

- Notes:**
- 1) Jacks mount to chassis brackets providing 8-9 inches of ground clearance with the air bags dumped.
 - 2) Level sensor attaches to bottom of structure; on lower hat section flanges or square tube.
 - 3) Hydraulic hose terminations for room #1, #3 & #4 require 90 degree swivel elbows.
 - 4) Hoses marked w90 will have the 90 deg. Fitting shipped loose
 - 5) All in floor slides to have automatic travel lock sensor

Item, Length	Description / Location	Qty	Color	Vendor PN		
Kit	(Items listed below)	1		8377	Measuring from inside of firewall, this is the end location of the hydraulic hoses where they attach to the slide mechanism.	
Pump	9-Function, 4 Rooms, & Jacks	1		7464BR		
Jack	17,000 lbs, 18" Stroke	4		7134		
Touch Pad	Located to the left of the drivers seat	1		2318		
Control Box	Attached to bottom of structure	1		2730		
Sync Cylinder	Mounted behind LP tank, Room 1	1		7387		
Sync Cylinder	Mounted behind LP tank, Room 4	1		7511		
Hose, 144	Pump to Jack, Left Front	2	Brown	2467		
Hose, 480	Pump to Jack, Left Rear	2	Orange	2490		
Hose, 144	Pump to Jack, Right Front	2	White	2467		
Hose, 480	Pump to Jack, Right Rear	2	Yellow	2490		
Hose, 180	Pump to synchronizing cylinder	2	Green	2470		Mounts to bracket on structure
Hose w90, 168	Sync cylinder to front slide, Room 1	2	Green	2469		99 / Drivers Side
Hose w90, 168	Sync cylinder to rear slide, Room 1	2	Green	2469		187 / Drivers Side
Slide Unit	Room 1 - 36" flush floor slide (angled)	2		7481		
Hose, 516	Pump to Room 2	2	Purple	2491	408 / Drivers Side	
Slide Unit	Room 2 - 30" Bed slide (Lippert)	1		134998		
Hose w90, 432	Pump to Room 3	2	Grey	2486	408 / Passenger side	
Slide Unit	Room 3 - 18" above floor slide	1		7469		
Hose, 180	Pump to synchronizing cylinder	2	Red	2470	Mounts to bracket on structure	
Hose w90, 228	Sync cylinder to front slide, Room 4	2	Red	2474	135 / Passenger Side	
Hose w90, 228	Sync cylinder to rear slide, Room 4	2	Red	2474	220 / Passenger Side	
Slide Unit	Room 4 - 18" above floor slide	2		7469		
Hose, 60	Pump to Generator Slide	2	Blue	2460	Inside generator tray	
Travel Clamp	(two per slide, except the bed slide)	6		HWH	N/A	
Options						
Revisions						

**40E Mandalay
EQUALIZER JACKS (FULLY AUTOMATIC)
STANDARD ON THIS UNIT**

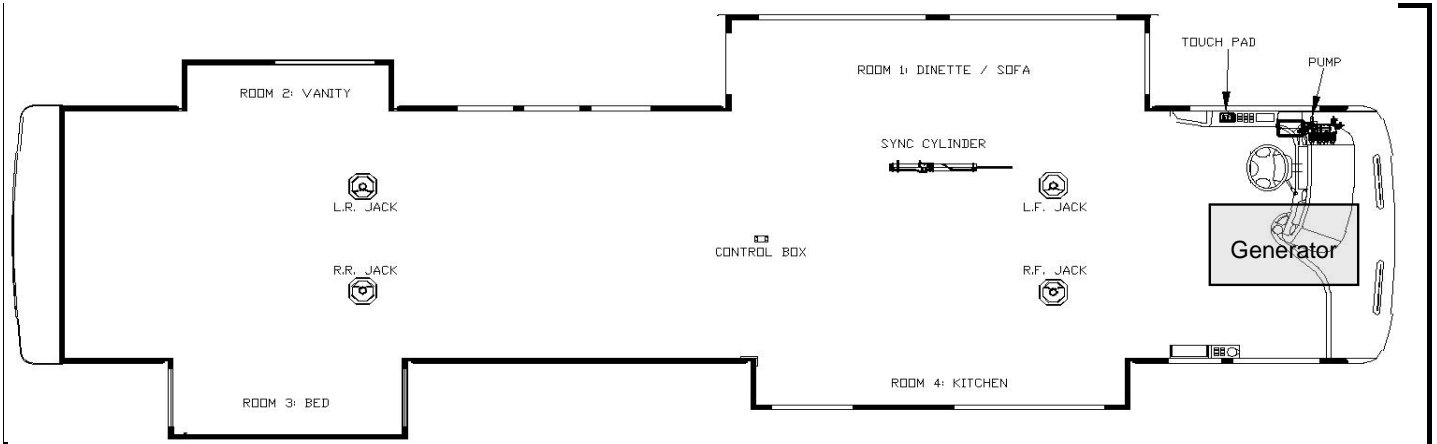

Notes:

- 1) Jacks mount to chassis brackets providing 8-9 inches of ground clearance with the air bags dumped.
- 2) Level sensor attaches to bottom of structure; on lower hat section flanges or square tube.
- 3) Hydraulic hose terminations for room #1, #2, & #4 require 90 degree swivel elbows.
- 4) Hoses marked w90 will have the 90 deg. Fitting shipped loose

Item, Length	Description / Location	Qty	Color	Vendor PN		
Kit	(Items listed below)	1		8357		
Pump	9-Function, 4 Rooms, & Jacks	1		7302		
Jack	17,000 lbs, 18" Stroke	4		7134	Measuring from inside of firewall, this is the end location of the hydraulic hoses where they attach to the slide mechanism.	
Touch Pad	Located to the left of the drivers seat	1		2318		
Control Box	Attached to bottom of structure	1		2319		
Sync Cylinder	Mounted behind LP tank	1		7387		
Hose, 144	Pump to Jack, Left Front	2	Brown	2467		
Hose, 480	Pump to Jack, Left Rear	2	Orange	2490		
Hose, 144	Pump to Jack, Right Front	2	White	2467		
Hose, 480	Pump to Jack, Right Rear	2	Yellow	2490		
Hose, 144	Pump to synchronizing cylinder	2	Green	2467		mounts to bracket on structure
Hose w90, 168	Sync cylinder to front slide, Room 1	1	Green	2469		103 / Drivers side
Hose w90, 168	Sync cylinder to rear slide, Room 1	1	Green	2469	196 / Drivers side	
	Pump to Room 1	N/A	Green			
Hose w90, 432	Pump to Room 2	2	Purple	2486	373 / Passenger Side	
Hose, 480	Pump to Room 3	2	Gray	2490	352 / Drivers Side	
Hose w90, 228	Pump to Room 4	2	Red	2474	153 / Passenger Side	
Hose, 60	Pump to Generator Slide	2			Inside generator tray	
Travel Clamp	(two per slide, except the bed slide)	6		HWH	N/A	

Options

Revisions

**40F Mandalay
EQUALIZER JACKS (FULLY AUTOMATIC)
STANDARD ON THIS UNIT**

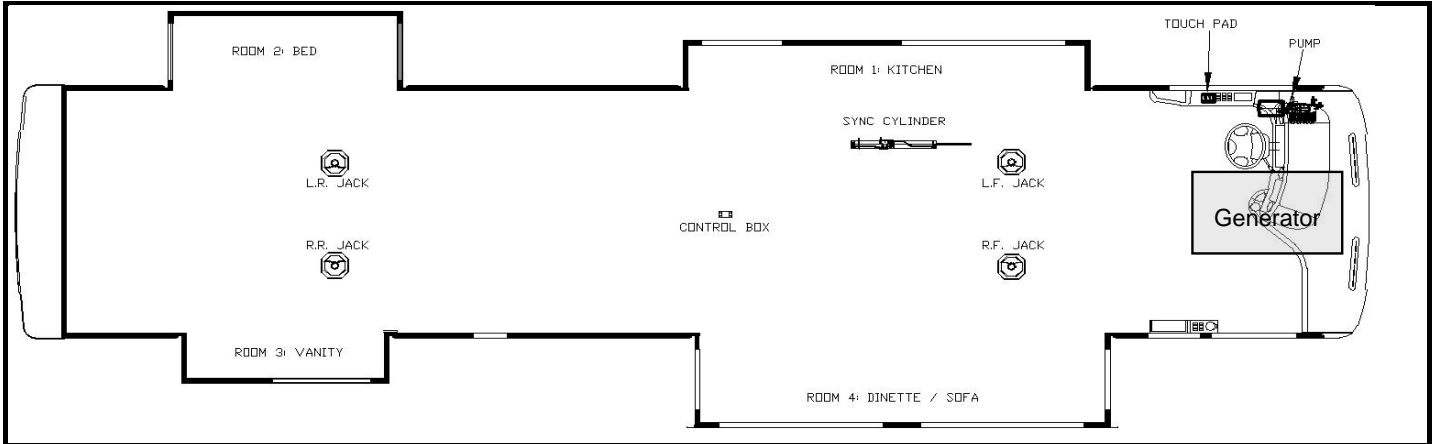

Notes:

- 1) Jacks mount to chassis brackets providing 8-9 inches of ground clearance with the air bags dumped.
- 2) Level sensor attaches to bottom of structure; on lower hat section flanges or square tube.
- 3) Hydraulic hose terminations for room #1, #3, & #4 require 90 degree swivel elbows.
- 4) Hoses marked w90 will have the 90 deg. Fitting shipped loose

Item, Length	Description / Location	Qty	Color	Vendor PN		
Kit	(Items listed below)	1		8278		
Pump	9-Function, 4 Rooms, & Jacks	1		7302		
Jack	17,000 lbs, 18" Stroke	4		7134	Measuring from inside of firewall, this is the end location of the hydraulic hoses where they attach to the slide mechanism.	
Touch Pad	Located to the left of the drivers seat	1		2318		
Control Box	Attached to bottom of structure	1		2319		
Sync Cylinder	Mounted behind LP tank	1		7387		
Hose, 144	Pump to Jack, Left Front	2	Brown	2467		
Hose, 480	Pump to Jack, Left Rear	2	Orange	2490		
Hose, 144	Pump to Jack, Right Front	2	White	2467		
Hose, 480	Pump to Jack, Right Rear	2	Yellow	2490		
Hose, 144	Pump to synchronizing cylinder	2	Green	2467		mounts to bracket on structure
Hose w90, 168	Sync cylinder to front slide, Room 4	1	Green	2469		103 / Passenger side
Hose w90, 168	Sync cylinder to rear slide, Room 4	1	Green	2469	196 / Passenger side	
Hose w90, 168	Pump to Room 1	2	Green	2469	151 / Driver Side	
Hose, 480	Pump to Room 2	2	Purple	2490	353 / Drivers Side	
Hose w90, 432	Pump to Room 3	2	Gray	2486	386 / Passenger Side	
	Pump to Room 4	N/A	Red			
Hose, 60	Pump to Generator Slide	2			Inside generator tray	
Travel Clamp	(two per slide, except the bed slide)	6		HWH	N/A	

Options

Revisions

**40G Mandalay
EQUALIZER JACKS (FULLY AUTOMATIC)
STANDARD ON THIS UNIT**

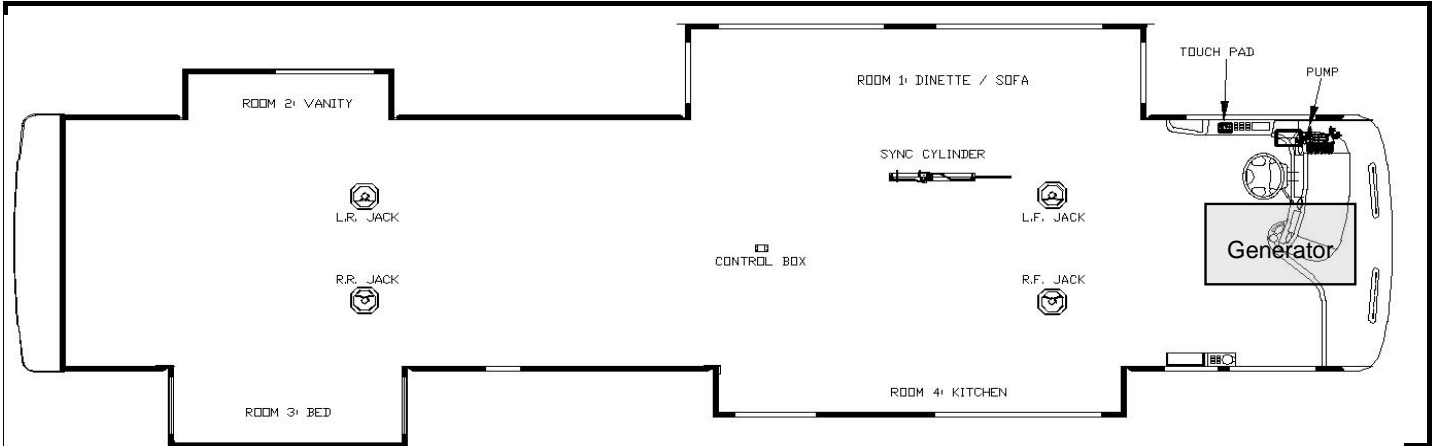

Notes:

- 1) Jacks mount to chassis brackets providing 8-9 inches of ground clearance with the air bags dumped.
- 2) Level sensor attaches to bottom of structure; on lower hat section flanges or square tube.
- 3) Hydraulic hose terminations for room #1, #3, & #4 require 90 degree swivel elbows.
- 4) Hoses marked w90 will have the 90 deg. Fitting shipped loose

Item, Length	Description / Location	Qty	Color	Vendor PN		
Kit	(Items listed below)	1		8278		
Pump	9-Function, 4 Rooms, & Jacks	1		7302		
Jack	17,000 lbs, 18" Stroke	4		7134	Measuring from inside of firewall, this is the end location of the hydraulic hoses where they attach to the slide mechanism.	
Touch Pad	Located to the left of the drivers seat	1		2318		
Control Box	Attached to bottom of structure	1		2319		
Sync Cylinder	Mounted behind LP tank	1		7387		
Hose, 144	Pump to Jack, Left Front	2	Brown	2467		
Hose, 480	Pump to Jack, Left Rear	2	Orange	2490		
Hose, 144	Pump to Jack, Right Front	2	White	2467		
Hose, 480	Pump to Jack, Right Rear	2	Yellow	2490		
Hose, 144	Pump to synchronizing cylinder	2	Green	2467		mounts to bracket on structure
Hose w90, 168	Sync cylinder to front slide, Room 1	1	Green	2469		99 / Drivers side
Hose w90, 168	Sync cylinder to rear slide, Room 1	1	Green	2469	201 / Drivers side	
	Pump to Room 1	N/A	Green			
Hose w90, 432	Pump to Room 2	2	Purple	2486	373 / Drivers Side	
Hose, 480	Pump to Room 3	2	Gray	2490	352 / Passenger Side	
Hose w90, 228	Pump to Room 4	2	Red	2474	153 / Passenger Side	
Hose, 60	Pump to Generator Slide	2			Inside generator tray	
Travel Clamp	(two per slide, except the bed slide)	6		HWH	N/A	

Options

Revisions

**40H Mandalay
EQUALIZER JACKS (FULLY AUTOMATIC)
STANDARD ON THIS UNIT**

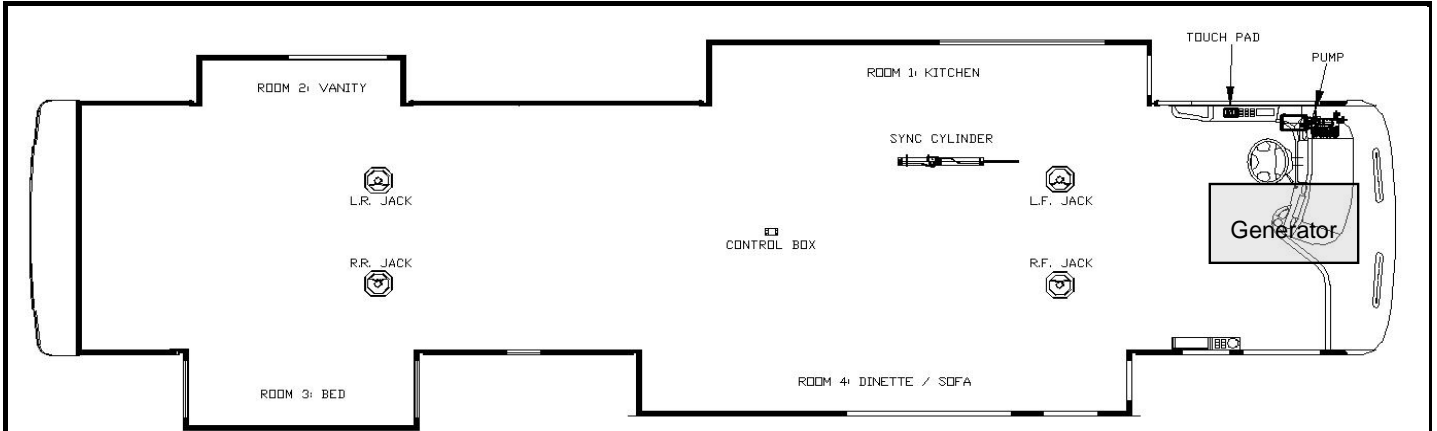

Notes:

- 1) Jacks mount to chassis brackets providing 8-9 inches of ground clearance with the air bags dumped.
- 2) Level sensor attaches to bottom of structure; on lower hat section flanges or square tube.
- 3) Hydraulic hose terminations for room #1, #3, & #4 require 90 degree swivel elbows.
- 4) Hoses marked w90 will have the 90 deg. Fitting shipped loose

Item, Length	Description / Location	Qty	Color	Vendor PN	
Kit	(Items listed below)	1		8357	
Pump	9-Function, 4 Rooms, & Jacks	1		7464BR	Measuring from inside of firewall, this is the end location of the hydraulic hoses where they attach to the slide mechanism.
Jack	17,000 lbs, 18" Stroke	4		7134	
Touch Pad	Located to the left of the drivers seat	1		2318	
Control Box	Attached to bottom of structure	1		2319	
Sync Cylinder	Mounted behind LP tank	2		7397	
Hose, 144	Pump to Jack, Left Front	2	Brown	2467	
Hose, 480	Pump to Jack, Left Rear	2	Orange	2490	
Hose, 144	Pump to Jack, Right Front	2	White	2467	
Hose, 480	Pump to Jack, Right Rear	2	Yellow	2490	
Hose, 144	Pump to synchronizing cylinder	2	Green	2467	
Hose, 144	Pump to synchronizing cylinder	2	Red	2467	Mounts to bracket on structure
Hose, 480	Pump to Room 2	2	Purple	2490	325 / Drivers Side
Hose w90, 432	Pump to Room 3	2	Gray	2486	355 / Passenger Side
Hose w90, 168	Sync cylinder to front slide, Room 1	2	Green	2469	95 / Drivers Side
Hose w90, 168	Sync cylinder to rear slide, Room 1	2	Green	2469	180 / Drivers Side
Hose w90, 168	Sync cylinder to front slide, Room 4	2	Red	2469	103 / Passenger side
Hose w90, 168	Sync cylinder to rear slide, Room 4	2	Red	2469	196 / Passenger side
Hose, 60	Pump to Generator Slide	2	Blue	2460	Inside generator tray
Travel Clamp	(two per slide, except the bed slide)	6		HWH	N/A

Options

Revisions

**32R WINDSPORT (22.5) TIRES
EQUALIZER JACKS (FULLY AUTOMATIC)
STANDARD ON THIS UNIT**

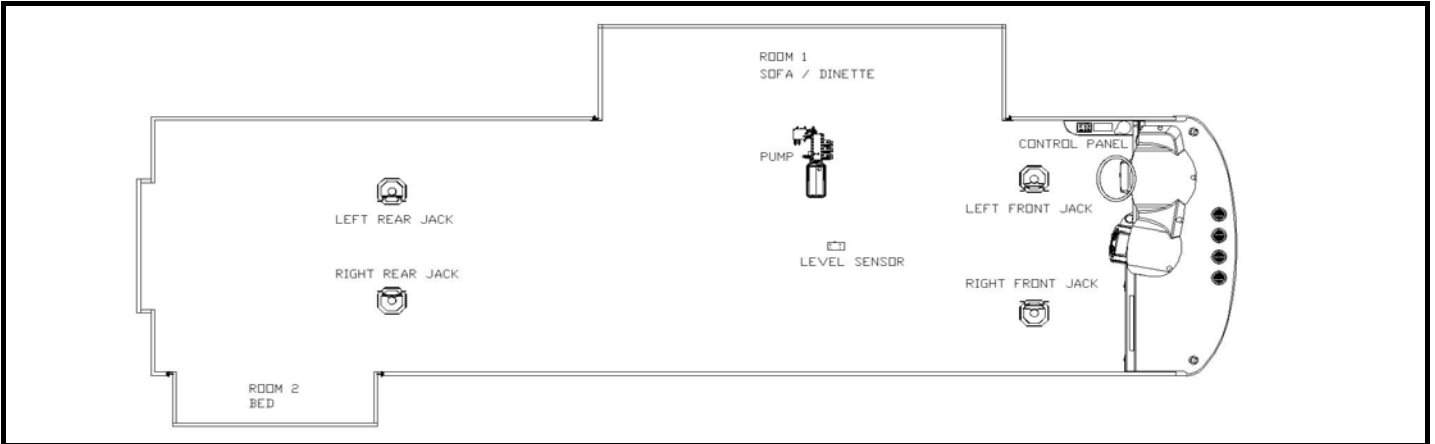

Notes:

- 1) Jacks mount in two different locations on bracket depending on tire size of chassis.
 - a) 19.5 Tires: Top hole in jack to top hole in bracket. Use 4 bolts in welded area of bracket.
 - b) 22.5 Tires: Top hole in jack to second hole in bracket. Use 6 bolts, 4 in welded area of bracket & 2 below welded area.

Item, Length	Description / Location	Qty	Color	Vendor PN	
Kit	(Items listed below)	1		8308	
Pump	6-Function, 2 Rooms & Jacks	1		7243	
Jack	12,000 lbs, 16" Stroke	4		7214	
Touch Pad	Located to the left of the drivers seat	1		2318	
Control Box	Attached to bottom of structure	1		2319	
Sync Cylinder	Mounted behind pump compartment	N/A		N/A	
Hose, 144	Pump to Jack, Left Front	2	Brown	2467	
Hose, 240	Pump to Jack, Left Rear	2	Orange	2475	
Hose, 180	Pump to Jack, Right Front	2	White	2470	
Hose, 288	Pump to Jack, Right Rear	2	Yellow	2478	
Hose, N/A	Pump to sync cylinder	N/A	Green	N/A	Inside pump compartment
Hose, N/A	Sync cylinder to front slide, Room 1	N/A	Green	N/A	N/A
Hose, N/A	Sync cylinder to rear slide, Room 1	N/A	Green	N/A	N/A
Hose, 36	Pump to Room 1	2	Green	2458	127 / Drivers Side
Hose, 372	Pump to Room 2	2	Purple	2481	310 / Passenger Side
Hose, N/A	Pump to Room 3	N/A	Gray	N/A	N/A
Hose, N/A	Pump to Room 4	N/A	Red	N/A	N/A
Hose, N/A	Pump to Generator Slide	N/A	N/A	N/A	N/A
Travel Clamp	Two per Slide	N/A		HWH	N/A

Measuring from inside of firewall, this is the end location of the hydraulic hoses where they attach to the slide mechanism.

Options

Revisions

1	New chart for Windsport for MY2007 due to Faux Flat on Rm 1, starting with the schedule released 04/24/06.

**34B WINDSPORT (22.5) TIRES
EQUALIZER JACKS (FULLY AUTOMATIC)
STANDARD ON THIS UNIT**

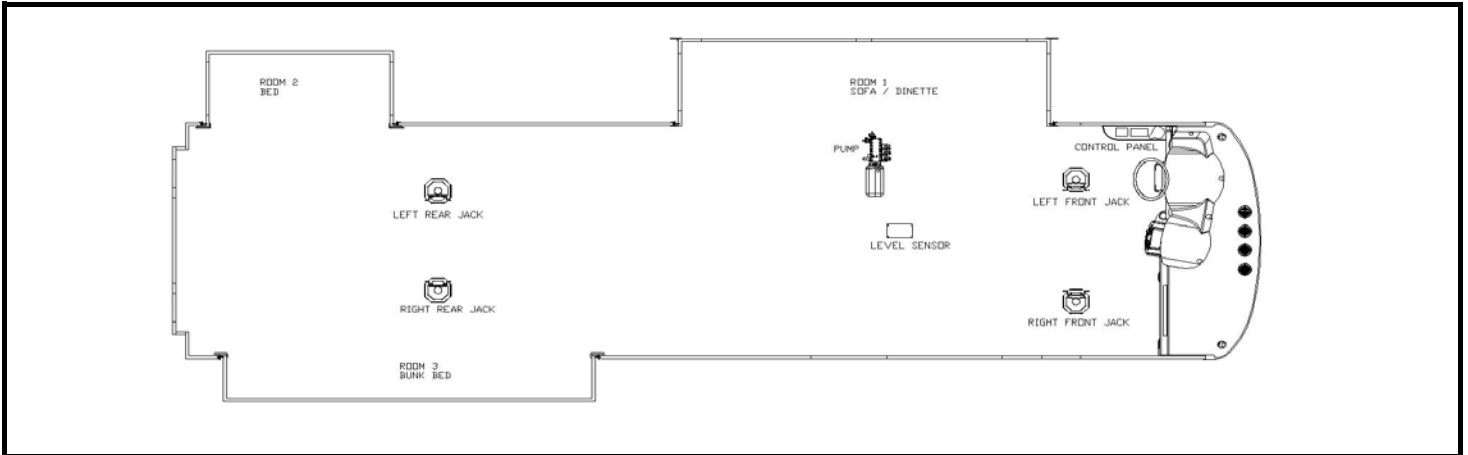

Notes:

- 1) Jacks mount in two different locations on bracket depending on tire size of chassis.
 - a) 19.5 Tires: Top hole in jack to top hole in bracket. Use 4 bolts in welded area of bracket.
 - b) 22.5 Tires: Top hole in jack to second hole in bracket. Use 6 bolts, 4 in welded area of bracket & 2 below welded area.

Item, Length	Description / Location	Qty	Color	Vendor PN		
Kit	(Items listed below)	1		8323	Measuring from inside of firewall, this is the end location of the hydraulic hoses where they attach to the slide mechanism.	
Pump	7-Function, 3 Rooms & Jacks	1		7301BR		
Jack	12,000 lbs, 16" Stroke	4		7214		
Touch Pad	Located to the left of the drivers seat	1		2318		
Control Box	Attached to bottom of structure	1		2567		
Sync Cylinder	Mounted behind pump compartment	N/A		N/A		
Hose, 144	Pump to Jack, Left Front	2	Brown	2467		
Hose, 264	Pump to Jack, Left Rear	2	Orange	2476		
Hose, 180	Pump to Jack, Right Front	2	White	2470		
Hose, 300	Pump to Jack, Right Rear	2	Yellow	2479		
Hose, N/A	Pump to sync cylinder	N/A	Green	N/A		Inside pump compartment
Hose, N/A	Sync cylinder to front slide, Room 1	N/A	Green	N/A		N/A
Hose, N/A	Sync cylinder to rear slide, Room 1	N/A	Green	N/A		N/A
Hose, 36	Pump to Room 1	2	Green	2458	127 / Drivers Side	
Hose, 372	Pump to Room 2	2	Purple	2481	347 / Drivers Side	
Hose w90, 372	Pump to Room 3	2	Gray	2481	307 / Passenger Side	
Hose, N/A	Pump to Room 4	N/A	Red	N/A	N/A	
Hose, N/A	Pump to Generator Slide	N/A		N/A	N/A	
Travel Clamp	Two per Slide	N/A		N/A	N/A	
Options						

**35B WINDSPORT (22.5) TIRES
EQUALIZER JACKS (FULLY AUTOMATIC)
STANDARD ON THIS UNIT**

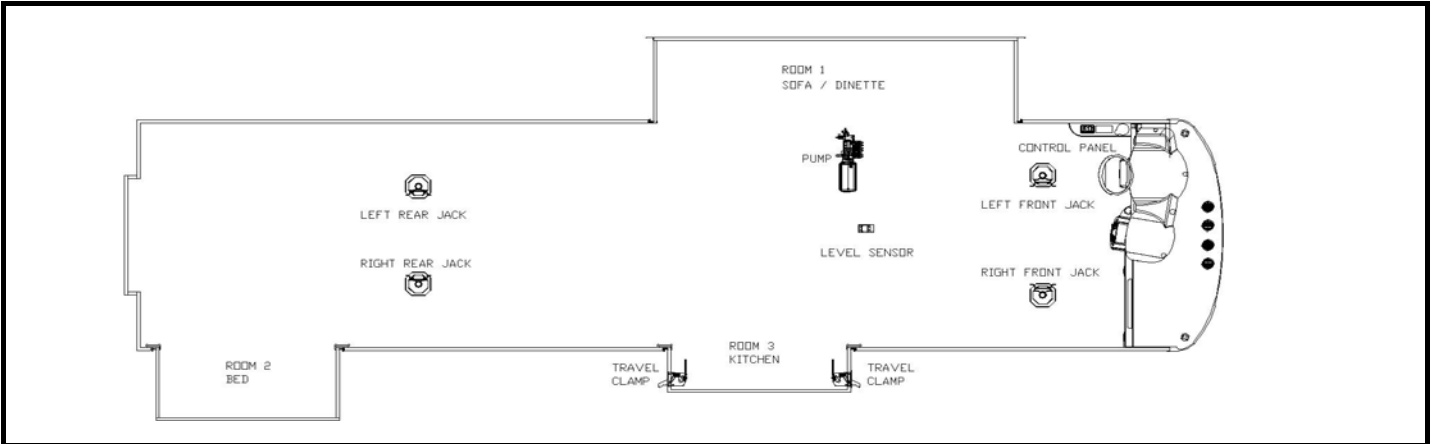

Notes:

- 1) Jacks mount in two different locations on bracket depending on tire size of chassis.
 - a) 19.5 Tires: Top hole in jack to top hole in bracket. Use 4 bolts in welded area of bracket.
 - b) 22.5 Tires: Top hole in jack to second hole in bracket. Use 6 bolts, 4 in welded area of bracket & 2 below welded area.

Item, Length	Description / Location	Qty	Color	Vendor PN		
Kit	(Items listed below)	1		8314		
Pump	7-Function, 2 Rooms & Jacks	1		7301		
Jack	12,000 lbs, 16" Stroke	4		7214		
Touch Pad	Located to the left of the drivers seat	1		2318		
Control Box	Attached to bottom of structure	1		2319		
Sync Cylinder	Mounted behind pump compartment	N/A		N/A		
Hose, 144	Pump to Jack, Left Front	2	Brown	2467	Measuring from inside of firewall, this is the end location of the hydraulic hoses where they attach to the slide mechanism.	
Hose, 264	Pump to Jack, Left Rear	2	Orange	2476		
Hose, 180	Pump to Jack, Right Front	2	White	2470		
Hose, 300	Pump to Jack, Right Rear	2	Yellow	2479		
Hose, N/A	Pump to sync cylinder	N/A	Green	N/A		Inside pump compartment
Hose, N/A	Sync cylinder to front slide, Room 1	N/A	Green	N/A		N/A
Hose, N/A	Sync cylinder to rear slide, Room 1	N/A	Green	N/A		N/A
Hose, 36	Pump to Room 1	2	Green	2458		127 / Drivers Side
Hose, 420	Pump to Room 2	2	Purple	2485		350 / Passenger Side
Hose w90, 108	Pump to Room 3	2	Gray	2464		160 / Passenger Side
Hose, N/A	Pump to Room 4	N/A	Red	N/A	N/A	
Hose, N/A	Pump to Generator Slide	N/A	N/A	N/A	N/A	
Travel Clamp	Two per Slide	2		HWH	N/A	

Options					

1	New chart for Windsport for MY2007 due to Faux Flat on Rm 1, starting with the schedule released 04/24/06.
2	Change name from 36B to 35B still starting with the release of 04/24/06

**36E WINDSPORT (22.5) TIRES
EQUALIZER JACKS (FULLY AUTOMATIC)
STANDARD ON THIS UNIT**

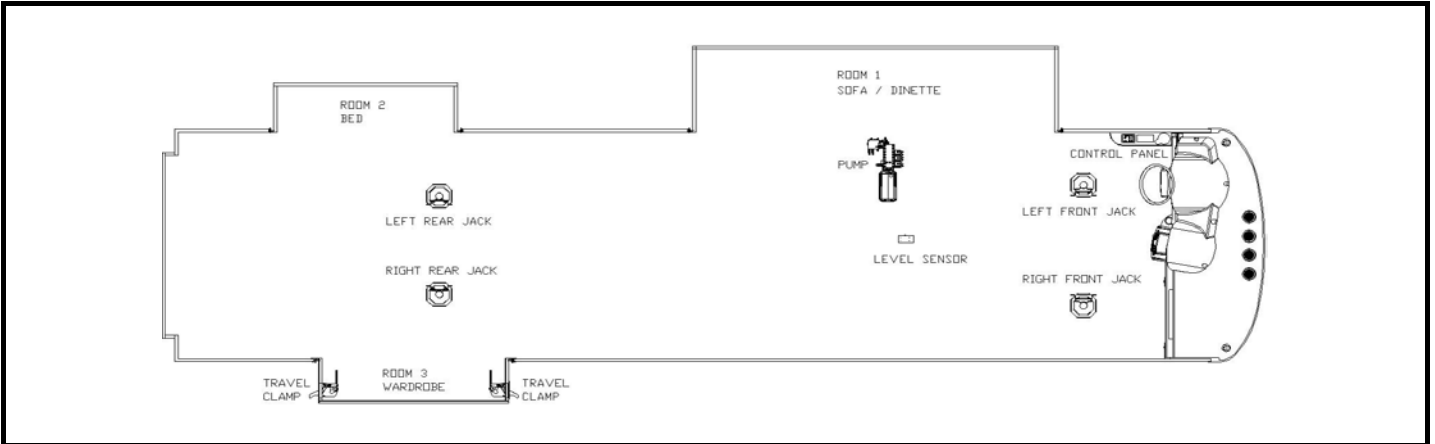

Notes:

- 1) Jacks mount in two different locations on bracket depending on tire size of chassis.
 - a) 19.5 Tires: Top hole in jack to top hole in bracket. Use 4 bolts in welded area of bracket.
 - b) 22.5 Tires: Top hole in jack to second hole in bracket. Use 6 bolts, 4 in welded area of bracket & 2 below welded area.

Item, Length	Description / Location	Qty	Color	Vendor PN	
Kit	(Items listed below)	1		8309	
Pump	7-Function, 3 Rooms & Jacks	1		7301	
Jack	12,000 lbs, 16" Stroke	4		7214	
Touch Pad	Located to the left of the drivers seat	1		2318	
Control Box	Attached to bottom of structure	1		2319	
Sync Cylinder	Mounted behind pump compartment	N/A		N/A	
Hose, 144	Pump to Jack, Left Front	2	Brown	2467	Measuring from inside of firewall, this is the end location of the hydraulic hoses where they attach to the slide mechanism.
Hose, 264	Pump to Jack, Left Rear	2	Orange	2476	
Hose, 180	Pump to Jack, Right Front	2	White	2470	
Hose, 300	Pump to Jack, Right Rear	2	Yellow	2479	
Hose, N/A	Pump to sync cylinder	N/A	Green	N/A	
Hose, N/A	Sync cylinder to front slide, Room 1	N/A	Green	N/A	N/A
Hose, N/A	Sync cylinder to rear slide, Room 1	N/A	Green	N/A	N/A
Hose, 36	Pump to Room 1	2	Green	2458	127 / Drivers Side
Hose, 372	Pump to Room 2	2	Purple	2481	319 / Drivers Side
Hose w/90, 372	Pump to Room 3	2	Gray	2481	319 / Passenger Side
Hose, N/A	Pump to Room 4	N/A	Red	N/A	N/A
Hose, N/A	Pump to Generator Slide	N/A	N/A	N/A	N/A
Travel Clamp	Two per Slide	2		HWH	N/A

Options

Revisions

1	New chart for Windsport for MY2007 due to Faux Flat on Rm 1, starting with the schedule released 04/24/06.

**36R WINDSPORT (22.5) TIRES
EQUALIZER JACKS (FULLY AUTOMATIC)
STANDARD ON THIS UNIT**

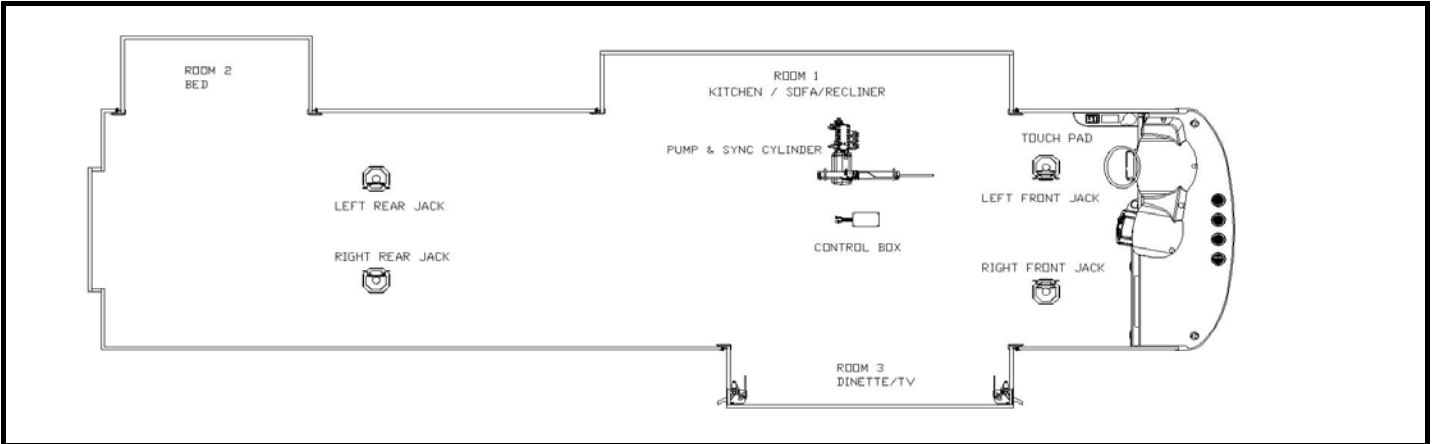

Notes:

- 1) Jacks mount in two different locations on bracket depending on tire size of chassis.
 - a) 19.5 Tires: Top hole in jack to top hole in bracket. Use 4 bolts in welded area of bracket.
 - b) 22.5 Tires: Top hole in jack to second hole in bracket. Use 6 bolts, 4 in welded area of bracket & 2 below welded area.
 - c) Hydraulic hose terminations for room #3 require 90 degree swivel elbows.

Item, Length	Description / Location	Qty	Color	Vendor PN		
Kit	(Items listed below)	1		8342	Measuring from inside of firewall, this is the end location of the hydraulic hoses where they attach to the slide mechanism.	
Pump	7-Function, 3 Rooms & Jacks	1		7301		
Jack	12,000 lbs, 16" Stroke	4		7214		
Touch Pad	Located to the left of the drivers seat	1		2318		
Control Box	Attached to bottom of structure	1		2319		
Sync Cylinder	Mounted behind pump compartment	1		7351		
Hose, 144	Pump to Jack, Left Front	2	Brown	2467		
Hose, 264	Pump to Jack, Left Rear	2	Orange	2476		
Hose, 180	Pump to Jack, Right Front	2	White	2470		
Hose, 300	Pump to Jack, Right Rear	2	Yellow	2479		
Hose, 36	Pump to sync cylinder	2	Gray	2458		Inside pump compartment
Hose, 120	Sync cylinder to front slide, Room 3	2	Gray	2465		90 / Passenger Side
Hose, 120	Sync cylinder to rear slide, Room 3	2	Gray	2465		145 / Passenger Side
Hose, 36	Pump to Room 1	2	Green	2458		127 / Drivers Side
Hose, 420	Pump to Room 2	2	Purple	2485	335 / Drivers Side	
Hose, N/A	Pump to Room 3	N/A	Gray	N/A	N/A	
Hose, N/A	Pump to Room 4	N/A	Red	N/A	N/A	
Hose, N/A	Pump to Generator Slide	N/A		N/A	N/A	
Travel Clamp	Two per Slide	2		HWH	N/A	

Options					

**36Z WINDSPORT (22.5) TIRES
EQUALIZER JACKS (FULLY AUTOMATIC)
STANDARD ON THIS UNIT**

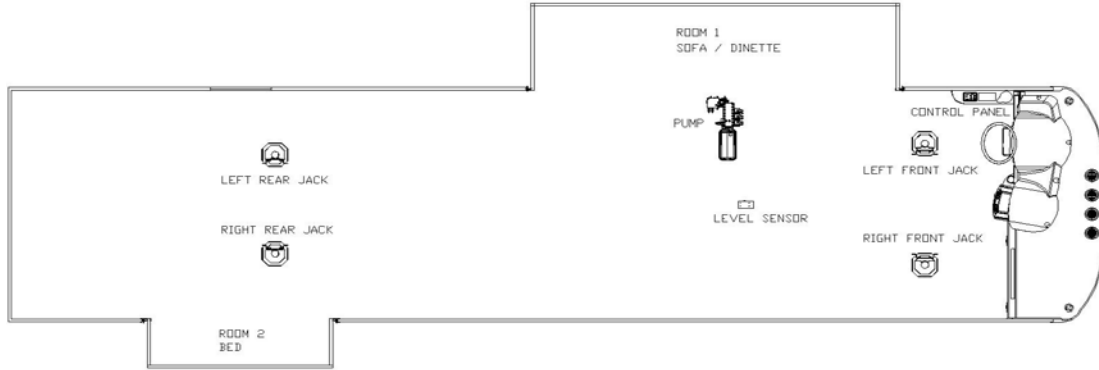

Notes:

1) Jacks mount in two different locations on bracket depending on tire size of chassis.

a) 19.5 Tires: Top hole in jack to top hole in bracket. Use 4 bolts in welded area of bracket.

b) 22.5 Tires: Top hole in jack to second hole in bracket. Use 6 bolts, 4 in welded area of bracket & 2 below welded area.

Item, Length	Description / Location	Qty	Color	Vendor PN	
Kit	(Items listed below)	1		8307	
Pump	6-Function, 2 Rooms & Jacks	1		7243	
Jack	12,000 lbs, 16" Stroke	4		7214	
Touch Pad	Located to the left of the drivers seat	1		2318	
Control Box	Attached to bottom of structure	1		2319	
Sync Cylinder	Mounted behind pump compartment	N/A		N/A	
Hose, 144	Pump to Jack, Left Front	2	Brown	2467	Measuring from inside of firewall, this is the end location of the hydraulic hoses where they attach to the slide mechanism.
Hose, 264	Pump to Jack, Left Rear	2	Orange	2476	
Hose, 180	Pump to Jack, Right Front	2	White	2470	
Hose, 300	Pump to Jack, Right Rear	2	Yellow	2479	
Hose, N/A	Pump to sync cylinder	N/A	Green	N/A	
Hose, N/A	Sync cylinder to front slide, Room 1	N/A	Green	N/A	N/A
Hose, N/A	Sync cylinder to rear slide, Room 1	N/A	Green	N/A	N/A
Hose, 36	Pump to Room 1	2	Green	2458	127 / Drivers Side
Hose, 372	Pump to Room 2	2	Purple	2481	319 / Passenger Side
Hose, N/A	Pump to Room 3	N/A	Gray	N/A	N/A
Hose, N/A	Pump to Room 4	N/A	Red	N/A	N/A
Hose, N/A	Pump to Generator Slide	N/A	N/A	N/A	N/A
Travel Clamp	Two per Slide	N/A		HWH	N/A

Options

Revisions

1	New chart for Windsport for MY2007 due to Faux Flat on Rm 1, starting with the schedule released 04/24/06.

**31D WINDSPORT (19.5) TIRES
EQUALIZER JACKS (FULLY AUTOMATIC)
OPTIONAL ON THIS UNIT**

FOR 30Q WINDSPORT

SEE CHART CH-0127

Notes:

Item, Length	Description / Location	Qty	Color	Vendor PN	
Kit	(Items listed below)				Measuring from inside of firewall, this is the end location of the hydraulic hoses where they attach to the slide mechanism.
Pump	X-Function, X Rooms & Jacks				
Jack	12,000 lbs, 16" Stroke				
Control Panel	Located to the left of the drivers seat				
Level Sensor	Attached to bottom of structure				
Sync Cylinder	Mounted behind pump compartment				
Hose, N/A	Pump to Jack, Left Front				
Hose, N/A	Pump to Jack, Left Rear				
Hose, N/A	Pump to Jack, Right Front				
Hose, N/A	Pump to Jack, Right Rear				
Hose, N/A	Pump to sync cylinder				
Hose, N/A	Sync cylinder to front slide, Room 1				
Hose, N/A	Sync cylinder to rear slide, Room 1				
Hose, N/A	Pump to Room 1				
Hose, N/A	Pump to Room 2				
Hose, N/A	Pump to Room 3				
Hose, N/A	Pump to Room 4				
Hose, N/A	Pump to Generator Slide				
Travel Clamp	Two per Slide				

Options					

Revisions	
1	New chart for Windsport for MY2007 due to Faux Flat on Rm 1, starting with the schedule released 04/24/06.

**31D WINDSPORT (19.5) TIRES
EQUALIZER JACKS (FULLY AUTOMATIC)
OPTIONAL ON THIS UNIT**

FOR 31D WINDSPORT

SEE CHART CH-0127

Notes:

Item, Length	Description / Location	Qty	Color	Vendor PN	
Kit	(Items listed below)				Measuring from inside of firewall, this is the end location of the hydraulic hoses where they attach to the slide mechanism.
Pump	X-Function, X Rooms & Jacks				
Jack	12,000 lbs, 16" Stroke				
Control Panel	Located to the left of the drivers seat				
Level Sensor	Attached to bottom of structure				
Sync Cylinder	Mounted behind pump compartment				
Hose, N/A	Pump to Jack, Left Front				
Hose, N/A	Pump to Jack, Left Rear				
Hose, N/A	Pump to Jack, Right Front				
Hose, N/A	Pump to Jack, Right Rear				
Hose, N/A	Pump to sync cylinder				
Hose, N/A	Sync cylinder to front slide, Room 1				
Hose, N/A	Sync cylinder to rear slide, Room 1				
Hose, N/A	Pump to Room 1				
Hose, N/A	Pump to Room 2				
Hose, N/A	Pump to Room 3				
Hose, N/A	Pump to Room 4				
Hose, N/A	Pump to Generator Slide				
Travel Clamp	Two per Slide				

Options

Revisions

1	New chart for Windsport for MY2007 due to Faux Flat on Rm 1, starting with the schedule released 04/24/06.

**31H WINDSPORT (19.5) TIRES
EQUALIZER JACKS (FULLY AUTOMATIC)
OPTIONAL ON THIS UNIT**

**FOR 31H WINDSPORT
SEE CHART CH-0127**

Notes:

Item, Length	Description / Location	Qty	Color	Vendor PN	
Kit	(Items listed below)				Measuring from inside of firewall, this is the end location of the hydraulic hoses where they attach to the slide mechanism.
Pump	X-Function, X Rooms & Jacks				
Jack	12,000 lbs, 16" Stroke				
Control Panel	Located to the left of the drivers seat				
Level Sensor	Attached to bottom of structure				
Sync Cylinder	Mounted behind pump compartment				
Hose, N/A	Pump to Jack, Left Front				
Hose, N/A	Pump to Jack, Left Rear				
Hose, N/A	Pump to Jack, Right Front				
Hose, N/A	Pump to Jack, Right Rear				
Hose, N/A	Pump to sync cylinder				
Hose, N/A	Sync cylinder to front slide, Room 1				
Hose, N/A	Sync cylinder to rear slide, Room 1				
Hose, N/A	Pump to Room 1				
Hose, N/A	Pump to Room 2				
Hose, N/A	Pump to Room 3				
Hose, N/A	Pump to Room 4				
Hose, N/A	Pump to Generator Slide				
Travel Clamp	Two per Slide				

Options

Revisions

1	New chart for Windsport for MY2007 due to Faux Flat on Rm 1, starting with the schedule released 04/24/06.

**32E WINDSPORT (19.5) TIRES
EQUALIZER JACKS (FULLY AUTOMATIC)
OPTIONAL ON THIS UNIT**

**FOR 32E WINDSPORT
SEE CHART CH-0127**

Notes:

Item, Length	Description / Location	Qty	Color	Vendor PN	
Kit	(Items listed below)				Measuring from inside of firewall, this is the end location of the hydraulic hoses where they attach to the slide mechanism.
Pump	X-Function, X Rooms & Jacks				
Jack	12,000 lbs, 16" Stroke				
Control Panel	Located to the left of the drivers seat				
Level Sensor	Attached to bottom of structure				
Sync Cylinder	Mounted behind pump compartment				
Hose, N/A	Pump to Jack, Left Front				
Hose, N/A	Pump to Jack, Left Rear				
Hose, N/A	Pump to Jack, Right Front				
Hose, N/A	Pump to Jack, Right Rear				
Hose, N/A	Pump to sync cylinder				
Hose, N/A	Sync cylinder to front slide, Room 1				
Hose, N/A	Sync cylinder to rear slide, Room 1				
Hose, N/A	Pump to Room 1				
Hose, N/A	Pump to Room 2				
Hose, N/A	Pump to Room 3				
Hose, N/A	Pump to Room 4				
Hose, N/A	Pump to Generator Slide				
Travel Clamp	Two per Slide				

Options					

Revisions	
1	New chart for Windsport for MY2007 due to Faux Flat on Rm 1, starting with the schedule released 04/24/06.

**32R WINDSPORT (22.5) TIRES
EQUALIZER JACKS (FULLY AUTOMATIC)
STANDARD ON THIS UNIT**

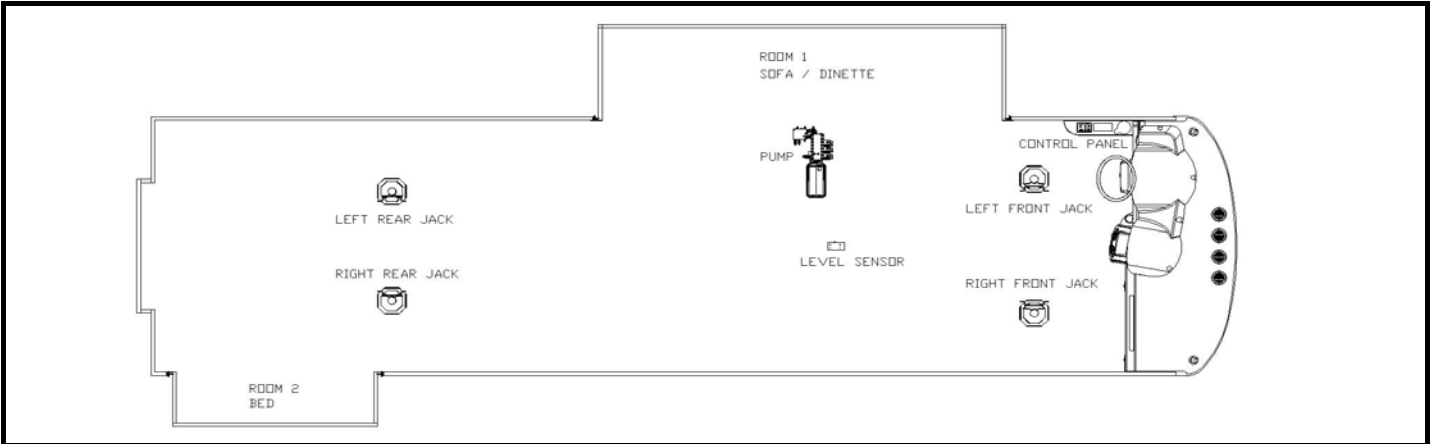

Notes:

- 1) Jacks mount in two different locations on bracket depending on tire size of chassis.
 - a) 19.5 Tires: Top hole in jack to top hole in bracket. Use 4 bolts in welded area of bracket.
 - b) 22.5 Tires: Top hole in jack to second hole in bracket. Use 6 bolts, 4 in welded area of bracket & 2 below welded area.

Item, Length	Description / Location	Qty	Color	Vendor PN	
Kit	(Items listed below)	1		8308	
Pump	6-Function, 2 Rooms & Jacks	1		7243BR	
Jack	12,000 lbs, 16" Stroke	4		7214	
Touch Pad	Located to the left of the drivers seat	1		2318	
Control Box	Attached to bottom of structure	1		2730	
Sync Cylinder	Mounted behind pump compartment	N/A		N/A	
Hose, 144	Pump to Jack, Left Front	2	Brown	2467	Measuring from inside of firewall, this is the end location of the hydraulic hoses where they attach to the slide mechanism.
Hose, 240	Pump to Jack, Left Rear	2	Orange	2475	
Hose, 180	Pump to Jack, Right Front	2	White	2470	
Hose, 288	Pump to Jack, Right Rear	2	Yellow	2478	
Hose, N/A	Pump to sync cylinder	N/A	Green	N/A	
Hose, N/A	Sync cylinder to front slide, Room 1	N/A	Green	N/A	N/A
Hose, N/A	Sync cylinder to rear slide, Room 1	N/A	Green	N/A	N/A
Hose, 36	Pump to Room 1	2	Green	2458	127 / Drivers Side
Hose, 372	Pump to Room 2	2	Purple	2481	310 / Passenger Side
Hose, N/A	Pump to Room 3	N/A	Gray	N/A	N/A
Hose, N/A	Pump to Room 4	N/A	Red	N/A	N/A
Hose, N/A	Pump to Generator Slide	N/A	N/A	N/A	N/A
Travel Clamp	Two per Slide	N/A		HWH	N/A

Options

Revisions

1	New chart for Windsport for MY2007 due to Faux Flat on Rm 1, starting with the schedule released 04/24/06.

**34B WINDSPORT (22.5) TIRES
EQUALIZER JACKS (FULLY AUTOMATIC)
STANDARD ON THIS UNIT**

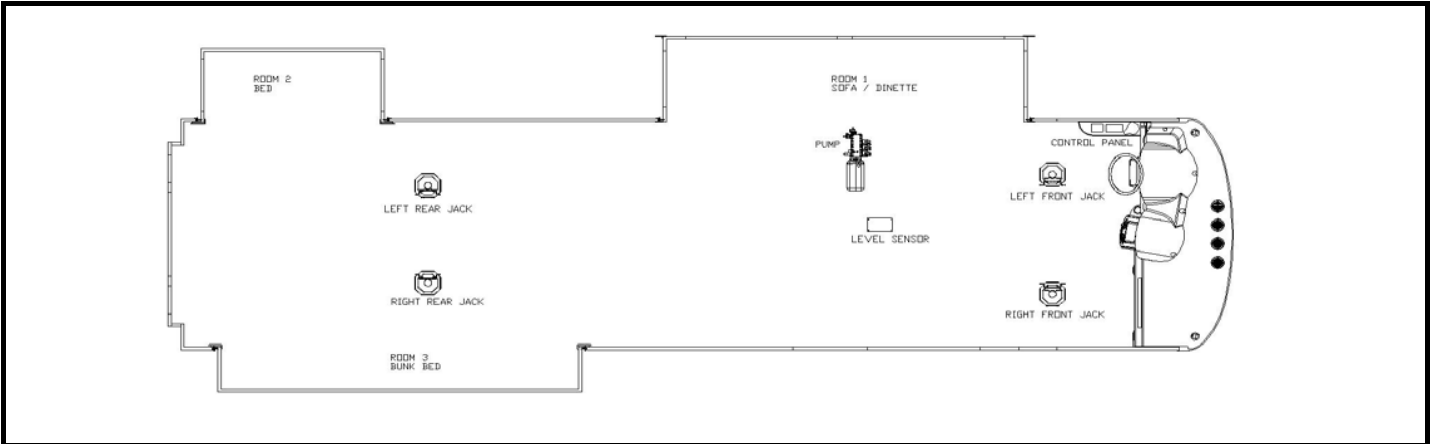

Notes:

- 1) Jacks mount in two different locations on bracket depending on tire size of chassis.
 - a) 19.5 Tires: Top hole in jack to top hole in bracket. Use 4 bolts in welded area of bracket.
 - b) 22.5 Tires: Top hole in jack to second hole in bracket. Use 6 bolts, 4 in welded area of bracket & 2 below welded area.

Item, Length	Description / Location	Qty	Color	Vendor PN	
Kit	(Items listed below)	1		8323	
Pump	7-Function, 3 Rooms & Jacks	1		7301BR	
Jack	12,000 lbs, 16" Stroke	4		7214	
Touch Pad	Located to the left of the drivers seat	1		2318	
Control Box	Attached to bottom of structure	1		2730	
Sync Cylinder	Mounted behind pump compartment	N/A		N/A	
Hose, 132	Pump to Jack, Left Front	2	Brown	2466	Measuring from inside of firewall, this is the end location of the hydraulic hoses where they attach to the slide mechanism.
Hose, 240	Pump to Jack, Left Rear	2	Orange	2475	
168	Pump to Jack, Right Front	2	White	2469	
Hose, 264	Pump to Jack, Right Rear	2	Yellow	2476	
Hose, N/A	Pump to sync cylinder	N/A	Green	N/A	
Hose, N/A	Sync cylinder to front slide, Room 1	N/A	Green	N/A	Inside pump compartment
Hose, N/A	Sync cylinder to rear slide, Room 1	N/A	Green	N/A	N/A
Hose, 36	Pump to Room 1	2	Green	2458	127 / Drivers Side
Hose, 372	Pump to Room 2	2	Purple	2481	347 / Drivers Side
Hose w90, 372	Pump to Room 3	2	Gray	2481	307 / Passenger Side
Hose, N/A	Pump to Room 4	N/A	Red	N/A	N/A
Hose, N/A	Pump to Generator Slide	N/A	N/A	N/A	N/A
Travel Clamp	Two per Slide	N/A		N/A	N/A

Options					

**34Y WINDSPORT (19.5) TIRES
EQUALIZER JACKS (FULLY AUTOMATIC)
STANDARD ON THIS UNIT**

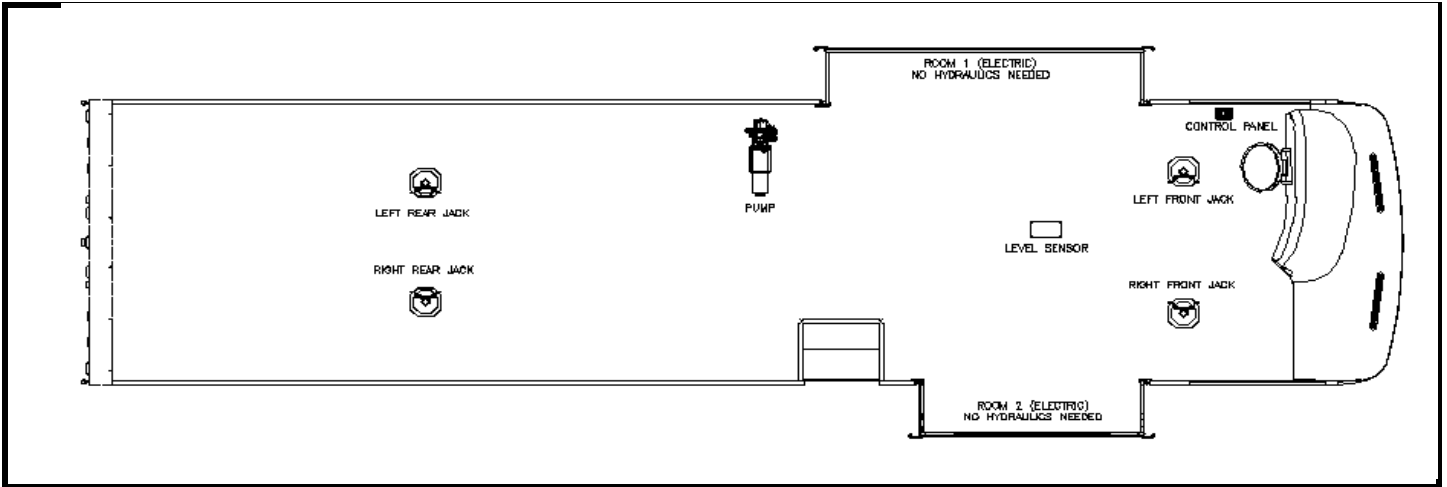

Notes:

1) Jacks mount 2nd hole from top to top mounting plate hole.

Item, Length	Description / Location	Qty	Color	Vendor PN		
Kit	(Items listed below)	1		8365	Measuring from back of cab floor, this is the end location of the hydraulic hoses where they attach to the slide mechanism.	
Pump	4-Function, Jacks Only	1		7239BR		
Jack	12,000 lbs, 16" Stroke	4		7214		
Touch Pad	Located to the left of the drivers seat	1		2318		
Control Box	Attached to bottom of structure	1		2730		
Sync Cylinder	Mounted behind pump compartment	N/A		N/A		
Hose, 180	Pump to Jack, Left Front	2	Brown	2470		
Hose, 180	Pump to Jack, Left Rear	2	Orange	2470		
Hose, 216	Pump to Jack, Right Front	2	White	2473		
Hose, 180	Pump to Jack, Right Rear	2	Yellow	2470		
Hose, N/A	Pump to Flow Divider	N/A	N/A	N/A		N/A
Hose, N/A	Flow divider to front slide, Room 1	N/A	N/A	N/A		N/A
Hose, N/A	Flow divider to rear slide, Room 1	N/A	N/A	N/A		N/A
Hose, N/A	Pump to Room 1	N/A	Green	N/A		N/A
Hose, N/A	Pump to Room 2	N/A	Purple	N/A		N/A
Hose, N/A	Pump to Room 3	N/A	Gray	N/A		N/A
Hose, N/A	Pump to Room 4	N/A	Red	N/A		N/A
Hose, N/A	Pump to Generator Slide	N/A	TBD	N/A		N/A
Travel Clamp	Two per Slide	N/A		HWH		N/A
Options						
Revisions						
	Description			By	Date	

**35B WINDSPORT (22.5) TIRES
EQUALIZER JACKS (FULLY AUTOMATIC)
STANDARD ON THIS UNIT**

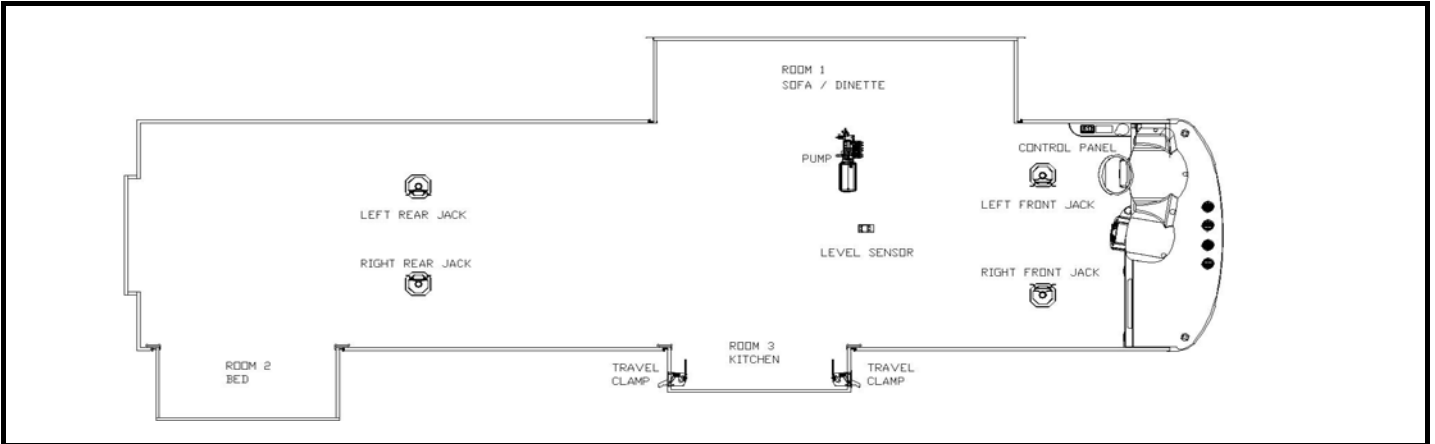

Notes:

- 1) Jacks mount in two different locations on bracket depending on tire size of chassis.
 - a) 19.5 Tires: Top hole in jack to top hole in bracket. Use 4 bolts in welded area of bracket.
 - b) 22.5 Tires: Top hole in jack to second hole in bracket. Use 6 bolts, 4 in welded area of bracket & 2 below welded area.

Item, Length	Description / Location	Qty	Color	Vendor PN	
Kit	(Items listed below)	1		8314	
Pump	7-Function, 3 Rooms & Jacks	1		7301BR	
Jack	12,000 lbs, 16" Stroke	4		7214	
Touch Pad	Located to the left of the drivers seat	1		2318	
Control Box	Attached to bottom of structure	1		2730	
Sync Cylinder	Mounted behind pump compartment	N/A		N/A	
Hose, 132	Pump to Jack, Left Front	2	Brown	2466	Measuring from inside of firewall, this is the end location of the hydraulic hoses where they attach to the slide mechanism.
Hose, 240	Pump to Jack, Left Rear	2	Orange	2475	
Hose, 180	Pump to Jack, Right Front	2	White	2470	
Hose, 264	Pump to Jack, Right Rear	2	Yellow	2476	
Hose, N/A	Pump to sync cylinder	N/A	Green	N/A	
Hose, N/A	Sync cylinder to front slide, Room 1	N/A	Green	N/A	N/A
Hose, N/A	Sync cylinder to rear slide, Room 1	N/A	Green	N/A	N/A
Hose, 36	Pump to Room 1	2	Green	2458	127 / Drivers Side
Hose, 420	Pump to Room 2	2	Purple	2485	350 / Passenger Side
Hose w90, 108	Pump to Room 3	2	Gray	2464	160 / Passenger Side
Hose, N/A	Pump to Room 4	N/A	Red	N/A	N/A
Hose, N/A	Pump to Generator Slide	N/A	N/A	N/A	N/A
Travel Clamp	Two per Slide	2		HWH	N/A

Options					

1	New chart for Windsport for MY2007 due to Faux Flat on Rm 1, starting with the schedule released 04/24/06.
2	Change name from 36B to 35B still starting with the release of 04/24/06

**36E WINDSPORT (22.5) TIRES
EQUALIZER JACKS (FULLY AUTOMATIC)
STANDARD ON THIS UNIT**

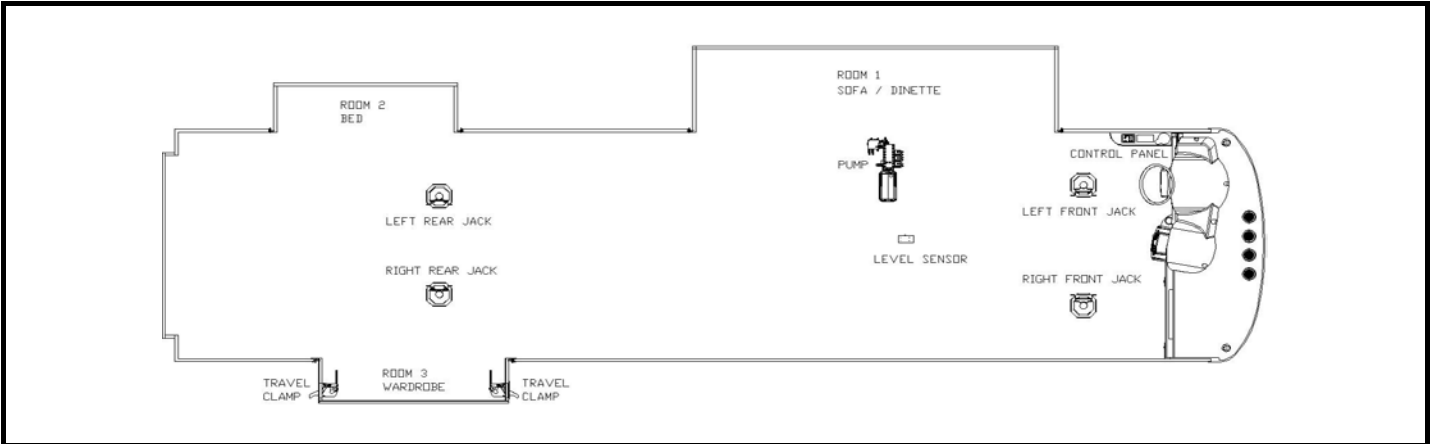

Notes:

1) Jacks mount in two different locations on bracket depending on tire size of chassis.

a) 19.5 Tires: Top hole in jack to top hole in bracket. Use 4 bolts in welded area of bracket.

b) 22.5 Tires: Top hole in jack to second hole in bracket. Use 6 bolts, 4 in welded area of bracket & 2 below welded area.

Item, Length	Description / Location	Qty	Color	Vendor PN	
Kit	(Items listed below)	1		8309	
Pump	7-Function, 3 Rooms & Jacks	1		7301BR	
Jack	12,000 lbs, 16" Stroke	4		7214	
Touch Pad	Located to the left of the drivers seat	1		2318	
Control Box	Attached to bottom of structure	1		2730	
Sync Cylinder	Mounted behind pump compartment	N/A		N/A	
Hose, 120	Pump to Jack, Left Front	2	Brown	2465	Measuring from inside of firewall, this is the end location of the hydraulic hoses where they attach to the slide mechanism.
Hose, 240	Pump to Jack, Left Rear	2	Orange	2475	
Hose, 168	Pump to Jack, Right Front	2	White	2469	
Hose, 252	Pump to Jack, Right Rear	2	Yellow	2587	
Hose, N/A	Pump to sync cylinder	N/A	Green	N/A	Inside pump compartment
Hose, N/A	Sync cylinder to front slide, Room 1	N/A	Green	N/A	N/A
Hose, N/A	Sync cylinder to rear slide, Room 1	N/A	Green	N/A	N/A
Hose, 36	Pump to Room 1	2	Green	2458	127 / Drivers Side
Hose, 372	Pump to Room 2	2	Purple	2481	319 / Drivers Side
Hose w/90, 372	Pump to Room 3	2	Gray	2481	319 / Passenger Side
Hose, N/A	Pump to Room 4	N/A	Red	N/A	N/A
Hose, N/A	Pump to Generator Slide	N/A	N/A	N/A	N/A
Travel Clamp	Two per Slide	2		HWH	N/A

Options

Revisions

1	New chart for Windsport for MY2007 due to Faux Flat on Rm 1, starting with the schedule released 04/24/06.

**36F WINDSPORT (22.5) TIRES
EQUALIZER JACKS (FULLY AUTOMATIC)
STANDARD ON THIS UNIT**

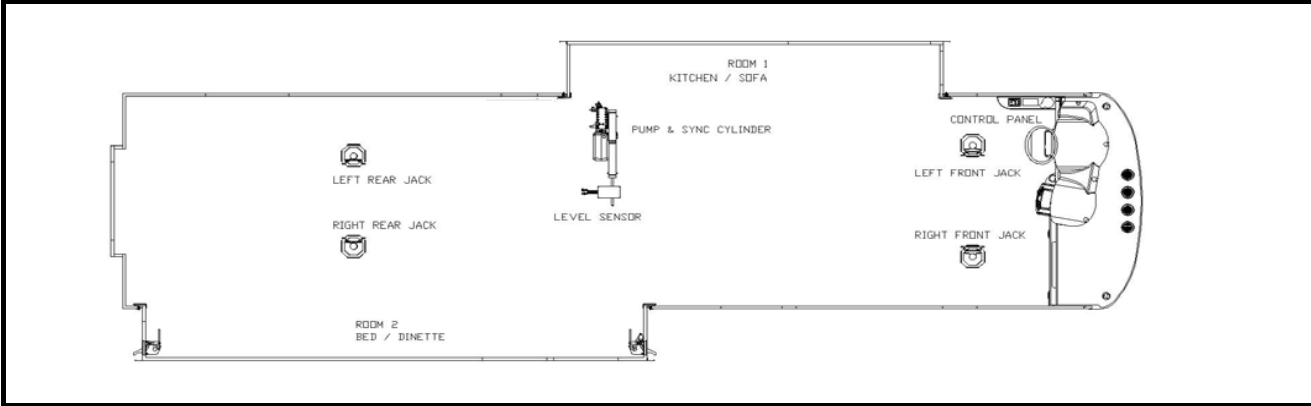

Notes:

- 1) Jacks mount in two different locations on bracket depending on tire size of chassis.
 - a) 19.5 Tires: Top hole in jack to top hole in bracket. Use 4 bolts in welded area of bracket.
 - b) 22.5 Tires: Top hole in jack to second hole in bracket. Use 6 bolts, 4 in welded area of bracket & 2 below welded area.
 - c) Hydraulic hose terminations for both rooms require 90 degree swivel elbows.

Item, Length	Description / Location	Qty	Color	Vendor PN	
Kit	(Items listed below)	1		8366	
Pump	6-Function, 2 Rooms & Jacks	1		7243BR	
Jack	12,000 lbs, 16" Stroke	4		7214	
Touch Pad	Located to the left of the drivers seat	1		2318	
Level Controller	Attached to bottom of structure	1		2730	
Sync Cylinder	Mounted inside pump compartment	1		7397	
Hose, 228	Pump to Jack, Left Front	2	Brown	2474	
Hose, 168	Pump to Jack, Left Rear	2	Orange	2469	
Hose, 264	Pump to Jack, Right Front	2	White	2476	
Hose, 204	Pump to Jack, Right Rear	2	Yellow	2472	
Hose, 36	Pump to sync cylinder	2	Purple	2458	Inside pump compartment
Hose w/90, 240	Sync cylinder to front slide, Room 2	2	Purple	2475	225 / Passenger Side
Hose w/90, 240	Sync cylinder to rear slide, Room 2	2	Purple	2475	371 / Passenger Side
Slide Unit	Room 2 - 24" flush floor slide (angled)	2		7388	
Hose w/90, 120	Pump to Room 1	2	Green	2465	135 / Drivers Side
Slide Unit	Room 1 - 24" above floor slide	1		7369	
Hose, N/A	Pump to Room 2	N/A	Purple	N/A	N/A
Hose, N/A	Pump to Room 3	N/A	Gray	N/A	N/A
Hose, N/A	Pump to Room 4	N/A	Red	N/A	N/A
Hose, N/A	Pump to Generator Slide	N/A		N/A	N/A
Travel Clamp	Two per Slide	2		HWH	N/A
Options					

**36R WINDSPORT (22.5) TIRES
EQUALIZER JACKS (FULLY AUTOMATIC)
STANDARD ON THIS UNIT**

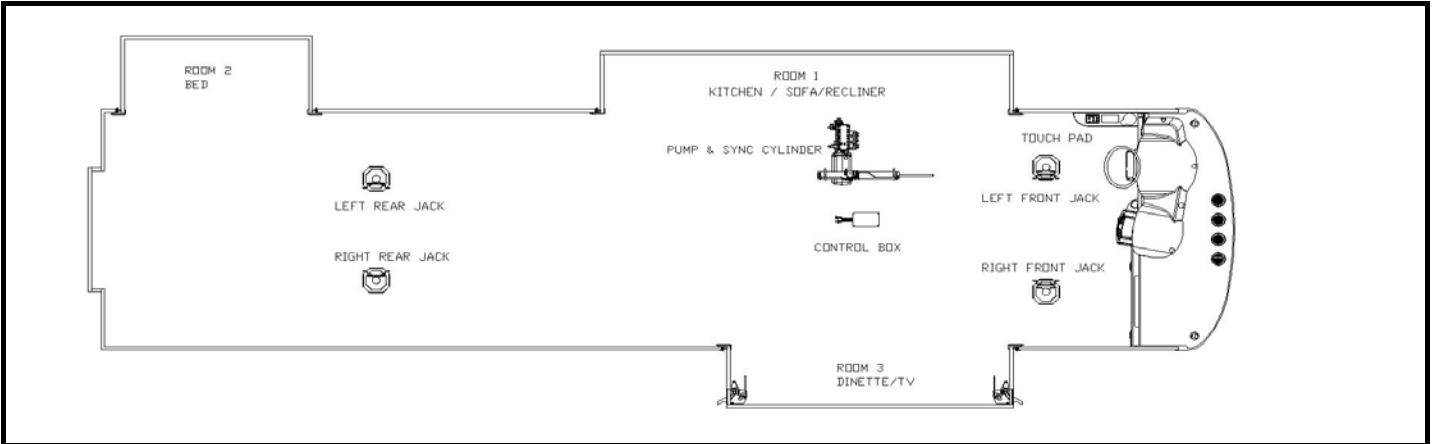

Notes:

- 1) Jacks mount in two different locations on bracket depending on tire size of chassis.
 - a) 19.5 Tires: Top hole in jack to top hole in bracket. Use 4 bolts in welded area of bracket.
 - b) 22.5 Tires: Top hole in jack to second hole in bracket. Use 6 bolts, 4 in welded area of bracket & 2 below welded area.
 - c) Hydraulic hose terminations for room #3 require 90 degree swivel elbows.

Item, Length	Description / Location	Qty	Color	Vendor PN		
Kit	(Items listed below)	1		8342		
Pump	7-Function, 3 Rooms & Jacks	1		7301BR		
Jack	12,000 lbs, 16" Stroke	4		7214		
Touch Pad	Located to the left of the drivers seat	1		2318		
Control Box	Attached to bottom of structure	1		2730		
Sync Cylinder	Mounted behind pump compartment	1		7397		
Hose, 120	Pump to Jack, Left Front	2	Brown	2465	Measuring from inside of firewall, this is the end location of the hydraulic hoses where they attach to the slide mechanism.	
Hose, 240	Pump to Jack, Left Rear	2	Orange	2475		
Hose, 168	Pump to Jack, Right Front	2	White	2469		
Hose, 240	Pump to Jack, Right Rear	2	Yellow	2475		
Hose, 36	Pump to sync cylinder	2	Gray	2458		Inside pump compartment
Hose, 120	Sync cylinder to front slide, Room 3	2	Gray	2465		90 / Passenger Side
Hose, 120	Sync cylinder to rear slide, Room 3	2	Gray	2465		145 / Passenger Side
Hose, 36	Pump to Room 1	2	Green	2458		127 / Drivers Side
Hose, 420	Pump to Room 2	2	Purple	2485		335 / Drivers Side
Hose, N/A	Pump to Room 3	N/A	Gray	N/A		N/A
Hose, N/A	Pump to Room 4	N/A	Red	N/A	N/A	
Hose, N/A	Pump to Generator Slide	N/A		N/A	N/A	
Travel Clamp	Two per Slide	2		HWH	N/A	

Options					

**36Z WINDSPORT (22.5) TIRES
EQUALIZER JACKS (FULLY AUTOMATIC)
STANDARD ON THIS UNIT**

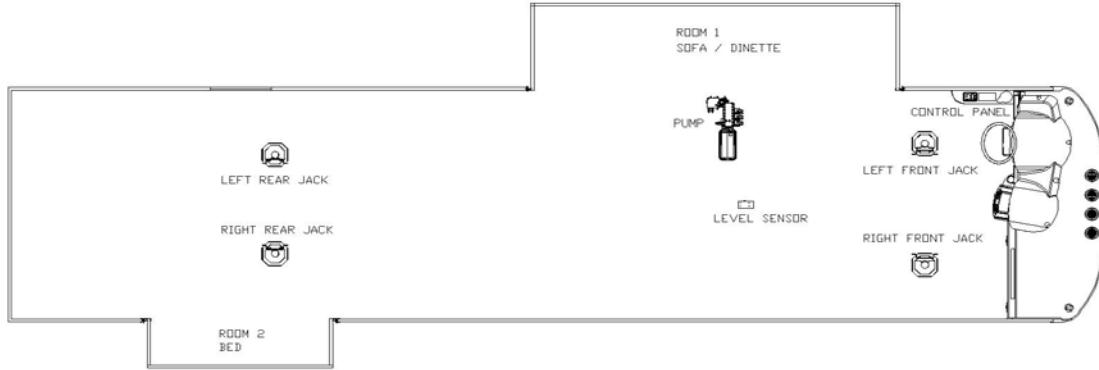

Notes:

1) Jacks mount in two different locations on bracket depending on tire size of chassis.

a) 19.5 Tires: Top hole in jack to top hole in bracket. Use 4 bolts in welded area of bracket.

b) 22.5 Tires: Top hole in jack to second hole in bracket. Use 6 bolts, 4 in welded area of bracket & 2 below welded area.

Item, Length	Description / Location	Qty	Color	Vendor PN	
Kit	(Items listed below)	1		8307	
Pump	6-Function, 2 Rooms & Jacks	1		7243BR	
Jack	12,000 lbs, 16" Stroke	4		7214	
Touch Pad	Located to the left of the drivers seat	1		2318	
Control Box	Attached to bottom of structure	1		2730	
Sync Cylinder	Mounted behind pump compartment	N/A		N/A	
Hose, 120	Pump to Jack, Left Front	2	Brown	2465	Measuring from inside of firewall, this is the end location of the hydraulic hoses where they attach to the slide mechanism.
Hose, 228	Pump to Jack, Left Rear	2	Orange	2474	
Hose, 156	Pump to Jack, Right Front	2	White	2468	
Hose, 252	Pump to Jack, Right Rear	2	Yellow	2587	
Hose, N/A	Pump to sync cylinder	N/A	Green	N/A	
Hose, N/A	Sync cylinder to front slide, Room 1	N/A	Green	N/A	N/A
Hose, N/A	Sync cylinder to rear slide, Room 1	N/A	Green	N/A	N/A
Hose, 36	Pump to Room 1	2	Green	2458	127 / Drivers Side
Hose, 372	Pump to Room 2	2	Purple	2481	319 / Passenger Side
Hose, N/A	Pump to Room 3	N/A	Gray	N/A	N/A
Hose, N/A	Pump to Room 4	N/A	Red	N/A	N/A
Hose, N/A	Pump to Generator Slide	N/A	N/A	N/A	N/A
Travel Clamp	Two per Slide	N/A		HWH	N/A

Options

Revisions

0	New chart for Windsport for MY2007 due to Faux Flat on Rm 1, starting with the schedule released 04/24/06.

**30Q WINDSPORT (19.5) TIRES
EQUALIZER JACKS (FULLY AUTOMATIC)
OPTIONAL ON THIS UNIT**



Notes:

- 1) Jacks mount in two different locations on bracket depending on tire size of chassis.
 a) 19.5 Tires: Top hole in jack to top hole in bracket. Use 4 bolts in welded area of bracket.
 b) 22.5 Tires: Top hole in jack to second hole in bracket. Use 6 bolts, 4 in welded area of bracket & 2 below welded area.

Item, Length	Description / Location	Qty	Color	Vendor PN	Measuring from inside of firewall, this is the end location of the hydraulic hoses where they attach to the slide mechanism.
Kit	(Items listed below)	1		8252	
Pump	4-Function, Jacks	1		7239BR	
Jack	12,000 lbs, 16" Stroke	4		7214	
Touch Pad	Located to the left of the drivers seat	1		2318	
Control Box	Attached to bottom of structure	1		2730	
Sync Cylinder	Mounted behind pump compartment	N/A		N/A	
Hose, 132	Pump to Jack, Left Front	2	Brown	2466	
Hose, 216	Pump to Jack, Left Rear	2	Orange	2473	
Hose, 180	Pump to Jack, Right Front	2	White	2470	
Hose, 264	Pump to Jack, Right Rear	2	Yellow	2476	
Hose, N/A	Pump to sync cylinder	N/A		N/A	
Hose, N/A	Sync cylinder to front slide, Room 1	N/A		N/A	
Hose, N/A	Sync cylinder to rear slide, Room 1	N/A		N/A	
Hose, N/A	Pump to Room 1	N/A		N/A	
Hose, N/A	Pump to Room 2	N/A		N/A	
Hose, N/A	Pump to Room 3	N/A		N/A	
Hose, N/A	Pump to Room 4	N/A		N/A	
Hose, N/A	Pump to Generator Slide	N/A		N/A	
Travel Clamp	Two per Slide	N/A		N/A	

Options

Item, Length	Description / Location	Qty	Color	Vendor PN

Revisions

1	New chart for Windsport for MY2007 due to Faux Flat on Rm 1, starting with the schedule released 04/24/06.
2	Update per Equalizer Specs

**31D WINDSPORT (19.5) TIRES
EQUALIZER JACKS (FULLY AUTOMATIC)
OPTIONAL ON THIS UNIT**

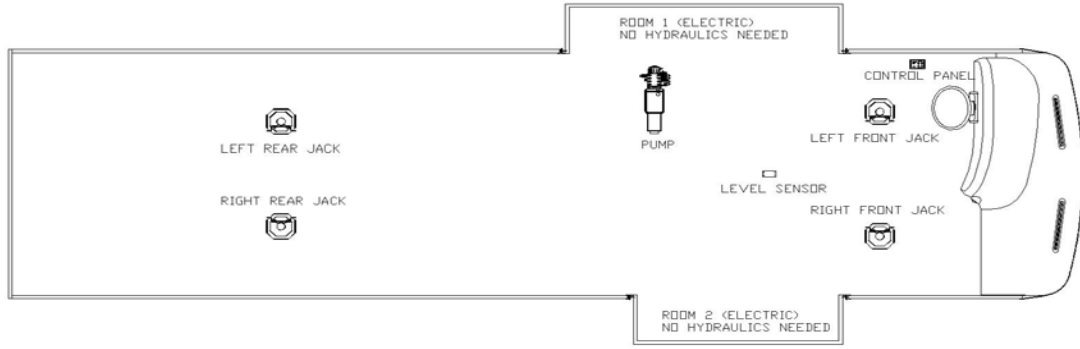

Notes:

- 1) Jacks mount in two different locations on bracket depending on tire size of chassis.
 - a) 19.5 Tires: Top hole in jack to top hole in bracket. Use 4 bolts in welded area of bracket.
 - b) 22.5 Tires: Top hole in jack to second hole in bracket. Use 6 bolts, 4 in welded area of bracket & 2 below welded area.

Item, Length	Description / Location	Qty	Color	Vendor PN	
Kit	(Items listed below)	1		8252	Measuring from inside of firewall, this is the end location of the hydraulic hoses where they attach to the slide mechanism.
Pump	X-Function, X Rooms & Jacks	1		7239BR	
Jack	12,000 lbs, 16" Stroke	4		7214	
Touch Pad	Located to the left of the drivers seat	1		2318	
Control Box	Attached to bottom of structure	1		2730	
Sync Cylinder	Mounted behind pump compartment	N/A		N/A	
Hose, 132	Pump to Jack, Left Front	2	Brown	2466	
Hose, 216	Pump to Jack, Left Rear	2	Orange	2473	
Hose, 180	Pump to Jack, Right Front	2	White	2470	
Hose, 264	Pump to Jack, Right Rear	2	Yellow	2476	
Hose, N/A	Pump to sync cylinder	N/A		N/A	
Hose, N/A	Sync cylinder to front slide, Room 1	N/A		N/A	
Hose, N/A	Sync cylinder to rear slide, Room 1	N/A		N/A	
Hose, N/A	Pump to Room 1	N/A		N/A	
Hose, N/A	Pump to Room 2	N/A		N/A	
Hose, N/A	Pump to Room 3	N/A		N/A	
Hose, N/A	Pump to Room 4	N/A		N/A	
Hose, N/A	Pump to Generator Slide	N/A		N/A	
Travel Clamp	Two per Slide	N/A		N/A	

Options

Revisions

1	New chart for Windsport for MY2007 due to Faux Flat on Rm 1, starting with the schedule released 04/24/06.
2	Update per Equalizer Specs

**31H WINDSPORT (19.5) TIRES
EQUALIZER JACKS (FULLY AUTOMATIC)
OPTIONAL ON THIS UNIT**

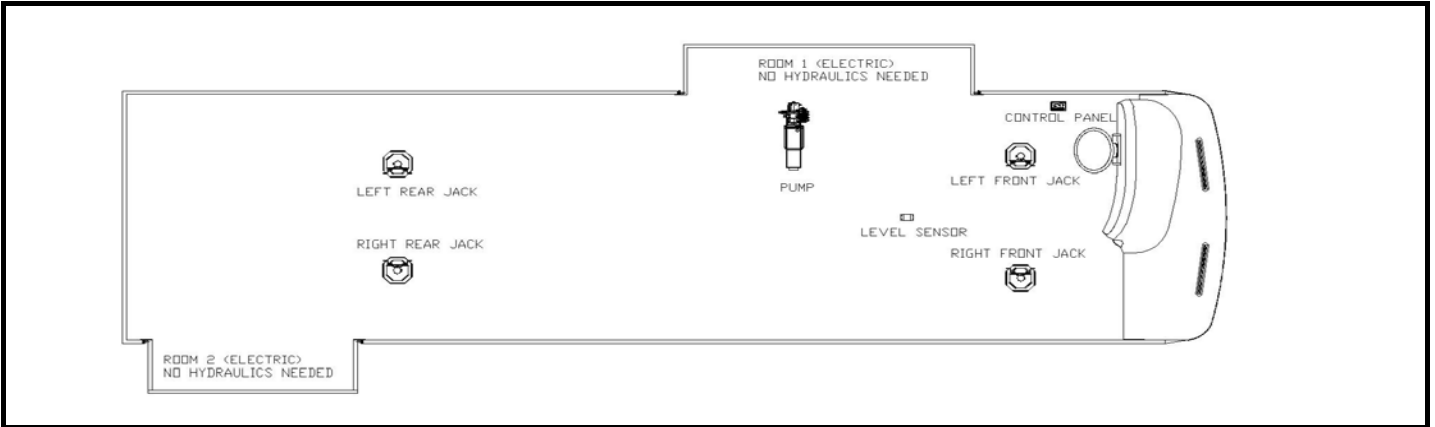

Notes:

- 1) Jacks mount in two different locations on bracket depending on tire size of chassis.
 - a) 19.5 Tires: Top hole in jack to top hole in bracket. Use 4 bolts in welded area of bracket.
 - b) 22.5 Tires: Top hole in jack to second hole in bracket. Use 6 bolts, 4 in welded area of bracket & 2 below welded area.

Item, Length	Description / Location	Qty	Color	Vendor PN	Measuring from inside of firewall, this is the end location of the hydraulic hoses where they attach to the slide mechanism.
Kit	(Items listed below)	1		8252	
Pump	X-Function, X Rooms & Jacks	1		7239BR	
Jack	12,000 lbs, 16" Stroke	4		7214	
Touch Pad	Located to the left of the drivers seat	1		2318	
Control Box	Attached to bottom of structure	1		2730	
Sync Cylinder	Mounted behind pump compartment	N/A		N/A	
Hose, 132	Pump to Jack, Left Front	2	Brown	2466	
Hose, 216	Pump to Jack, Left Rear	2	Orange	2473	
Hose, 180	Pump to Jack, Right Front	2	White	2470	
Hose, 264	Pump to Jack, Right Rear	2	Yellow	2476	
Hose, N/A	Pump to sync cylinder	N/A		N/A	
Hose, N/A	Sync cylinder to front slide, Room 1	N/A		N/A	
Hose, N/A	Sync cylinder to rear slide, Room 1	N/A		N/A	
Hose, N/A	Pump to Room 1	N/A		N/A	
Hose, N/A	Pump to Room 2	N/A		N/A	
Hose, N/A	Pump to Room 3	N/A		N/A	
Hose, N/A	Pump to Room 4	N/A		N/A	
Hose, N/A	Pump to Generator Slide	N/A		N/A	
Travel Clamp	Two per Slide	N/A		N/A	

Options				

Revisions	
1	New chart for Windsport for MY2007 due to Faux Flat on Rm 1, starting with the schedule released 04/24/06.
2	Update per Equalizer Specs

**32E WINDSPORT (19.5) TIRES
EQUALIZER JACKS (FULLY AUTOMATIC)
OPTIONAL ON THIS UNIT**

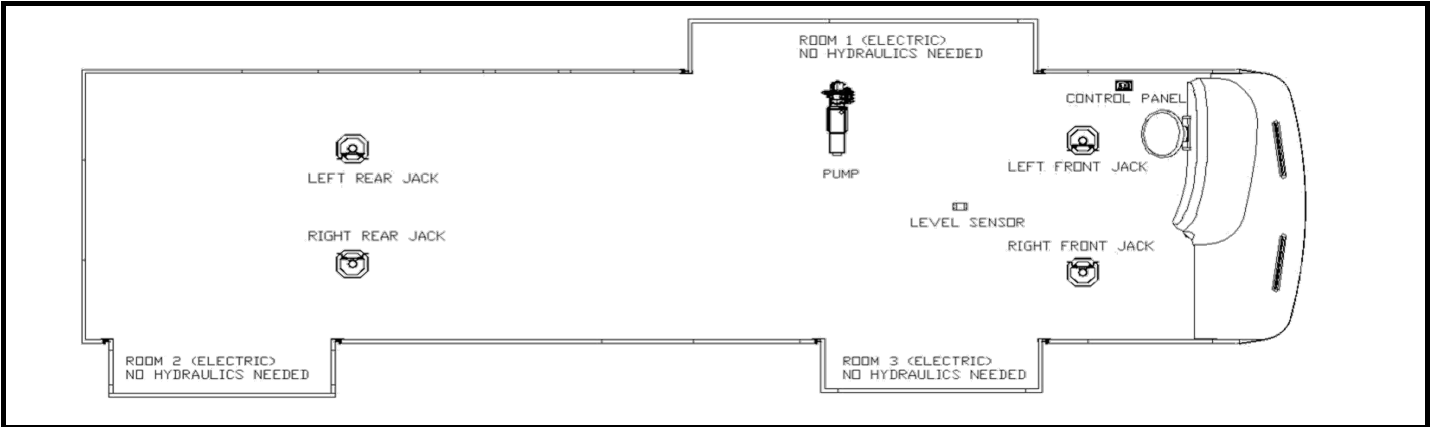

Notes:

- 1) Jacks mount in two different locations on bracket depending on tire size of chassis.
 - a) 19.5 Tires: Top hole in jack to top hole in bracket. Use 4 bolts in welded area of bracket.
 - b) 22.5 Tires: Top hole in jack to second hole in bracket. Use 6 bolts, 4 in welded area of bracket & 2 below welded area.

Item, Length	Description / Location	Qty	Color	Vendor PN	Measuring from inside of firewall, this is the end location of the hydraulic hoses where they attach to the slide mechanism.
Kit	(Items listed below)	1		8252	
Pump	X-Function, X Rooms & Jacks	1		7239BR	
Jack	12,000 lbs, 16" Stroke	4		7214	
Touch Pad	Located to the left of the drivers seat	1		2318	
Control Box	Attached to bottom of structure	1		2730	
Sync Cylinder	Mounted behind pump compartment	N/A		N/A	
Hose, 132	Pump to Jack, Left Front	2	Brown	2466	
Hose, 216	Pump to Jack, Left Rear	2	Orange	2473	
Hose, 180	Pump to Jack, Right Front	2	White	2470	
Hose, 264	Pump to Jack, Right Rear	2	Yellow	2476	
Hose, N/A	Pump to sync cylinder	N/A		N/A	
Hose, N/A	Sync cylinder to front slide, Room 1	N/A		N/A	
Hose, N/A	Sync cylinder to rear slide, Room 1	N/A		N/A	
Hose, N/A	Pump to Room 1	N/A		N/A	
Hose, N/A	Pump to Room 2	N/A		N/A	
Hose, N/A	Pump to Room 3	N/A		N/A	
Hose, N/A	Pump to Room 4	N/A		N/A	
Hose, N/A	Pump to Generator Slide	N/A		N/A	
Travel Clamp	Two per Slide	N/A		N/A	

Options				

Revisions	
1	New chart for Windsport for MY2007 due to Faux Flat on Rm 1, starting with the schedule released 04/24/06.
2	Update per Equalizer Specs

**33T WINDSPORT (19.5) TIRES
EQUALIZER JACKS (FULLY AUTOMATIC)
OPTIONAL ON THIS UNIT**

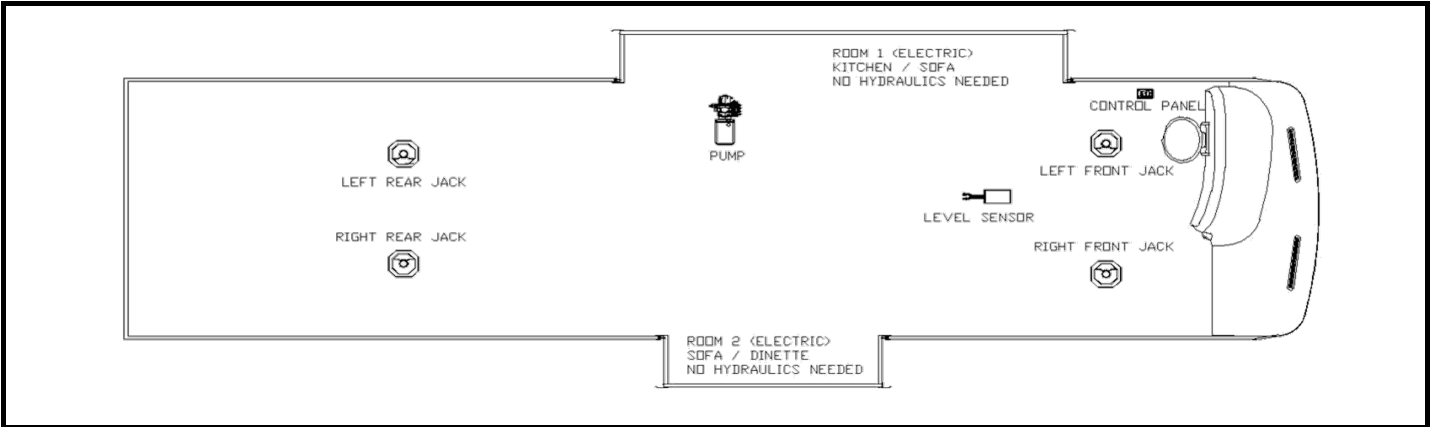

Notes:

- 1) Jacks mount in two different locations on bracket depending on tire size of chassis.
 - a) 19.5 Tires: Top hole in jack to top hole in bracket. Use 4 bolts in welded area of bracket.
 - b) 22.5 Tires: Top hole in jack to second hole in bracket. Use 6 bolts, 4 in welded area of bracket & 2 below welded area.

Item, Length	Description / Location	Qty	Color	Vendor PN	Measuring from inside of firewall, this is the end location of the hydraulic hoses where they attach to the slide mechanism.
Kit	(Items listed below)	1		8381	
Pump	X-Function, X Rooms & Jacks	1		7239BR	
Jack	12,000 lbs, 16" Stroke	4		7214	
Touch Pad	Located to the left of the drivers seat	1		2318	
Control Box	Attached to bottom of structure	1		2730	
Flow Divider	Mounted behind pump compartment	N/A		N/A	
Hose, 204	Pump to Jack, Left Front	2	Brown	2472	
Hose, 180	Pump to Jack, Left Rear	2	Orange	2470	
Hose, 252	Pump to Jack, Right Front	2	White	2587	
Hose, 216	Pump to Jack, Right Rear	2	Yellow	2473	
Hose, N/A	Pump to sync cylinder	N/A	Green	N/A	
Hose, N/A	Sync cylinder to front slide, Room 1	N/A	Green	N/A	
Hose, N/A	Sync cylinder to rear slide, Room 1	N/A	Green	N/A	
Hose, N/A	Pump to Room 1	N/A	Green	N/A	
Hose, N/A	Pump to Room 2	N/A	Purple	N/A	
Hose, N/A	Pump to Room 3	N/A	Gray	N/A	
Hose, N/A	Pump to Room 4	N/A	Red	N/A	
Hose, N/A	Pump to Generator Slide	N/A		N/A	
Travel Clamp	Two per Slide	N/A		HWH	

Options				

Revisions	
1	New chart for Windsport for MY2007 due to Faux Flat on Rm 1, starting with the schedule released 04/24/06.
2	Update per Equalizer Specs

**32R WINDSPORT (22.5) TIRES
EQUALIZER JACKS (FULLY AUTOMATIC)
STANDARD ON THIS UNIT**

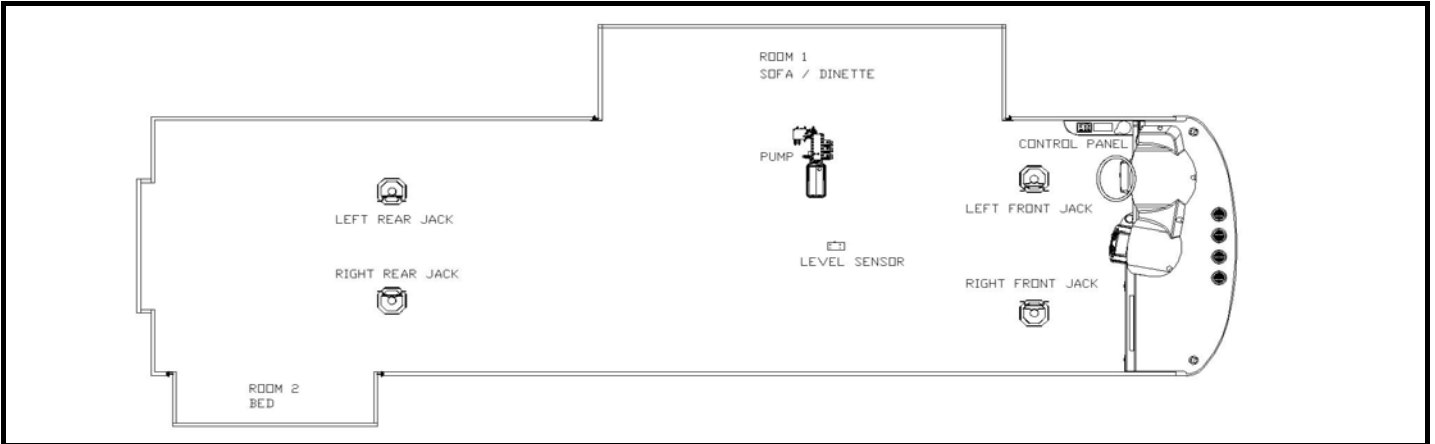

Notes:

- 1) Jacks mount in two different locations on bracket depending on tire size of chassis.
 - a) 19.5 Tires: Top hole in jack to top hole in bracket. Use 4 bolts in welded area of bracket.
 - b) 22.5 Tires: Top hole in jack to second hole in bracket. Use 6 bolts, 4 in welded area of bracket & 2 below welded area.

Item, Length	Description / Location	Qty	Color	Vendor PN	
Kit	(Items listed below)	1		8308	
Pump	6-Function, 2 Rooms & Jacks	1		7243BR	
Jack	12,000 lbs, 16" Stroke	4		7214	
Touch Pad	Located to the left of the drivers seat	1		2318	
Control Box	Attached to bottom of structure	1		2730	
Sync Cylinder	Mounted behind pump compartment	N/A		N/A	
Hose, 144	Pump to Jack, Left Front	2	Brown	2467	Measuring from inside of firewall, this is the end location of the hydraulic hoses where they attach to the slide mechanism.
Hose, 240	Pump to Jack, Left Rear	2	Orange	2475	
Hose, 180	Pump to Jack, Right Front	2	White	2470	
Hose, 288	Pump to Jack, Right Rear	2	Yellow	2478	
Hose, N/A	Pump to sync cylinder	N/A	Green	N/A	
Hose, N/A	Sync cylinder to front slide, Room 1	N/A	Green	N/A	N/A
Hose, N/A	Sync cylinder to rear slide, Room 1	N/A	Green	N/A	N/A
Hose, 36	Pump to Room 1	2	Green	2458	127 / Drivers Side
Hose, 372	Pump to Room 2	2	Purple	2481	310 / Passenger Side
Hose, N/A	Pump to Room 3	N/A	Gray	N/A	N/A
Hose, N/A	Pump to Room 4	N/A	Red	N/A	N/A
Hose, N/A	Pump to Generator Slide	N/A	N/A	N/A	N/A
Travel Clamp	Two per Slide	N/A		HWH	N/A

Options

Revisions

1	New chart for Windsport for MY2007 due to Faux Flat on Rm 1, starting with the schedule released 04/24/06.
2	Update per Equalizer Specs

**34B WINDSPORT/MAGELLAN (22.5) TIRES
EQUALIZER JACKS (FULLY AUTOMATIC)
STANDARD ON THIS UNIT**

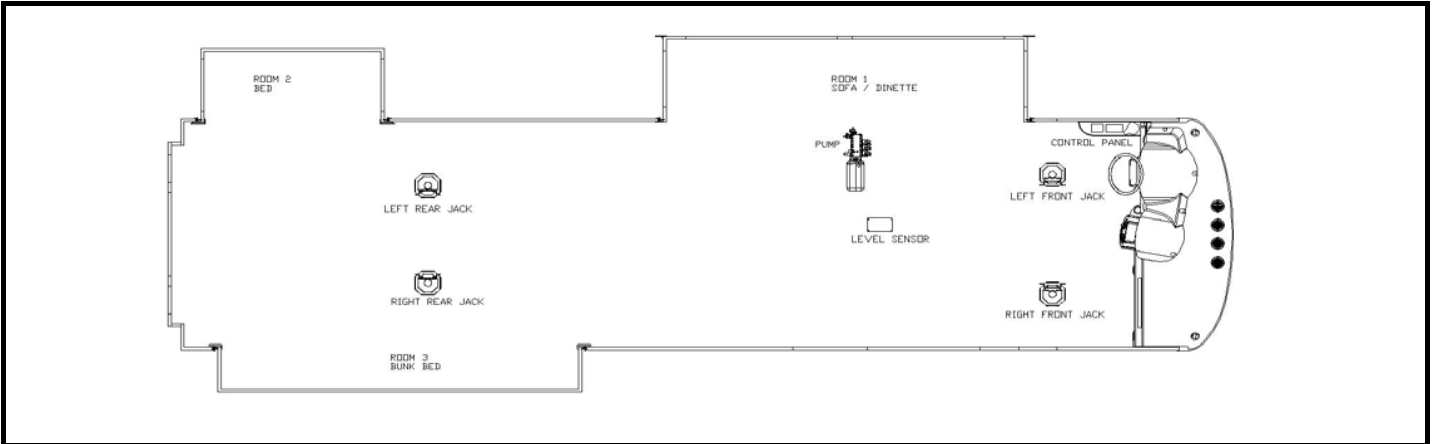

Notes:

- 1) Jacks mount in two different locations on bracket depending on tire size of chassis.
 - a) 19.5 Tires: Top hole in jack to top hole in bracket. Use 4 bolts in welded area of bracket.
 - b) 22.5 Tires: Top hole in jack to second hole in bracket. Use 6 bolts, 4 in welded area of bracket & 2 below welded area.

Item, Length	Description / Location	Qty	Color	Vendor PN	
Kit	(Items listed below)	1		8323	
Pump	7-Function, 3 Rooms & Jacks	1		7301BR	
Jack	12,000 lbs, 16" Stroke	4		7214	
Touch Pad	Located to the left of the drivers seat	1		2318	
Control Box	Attached to bottom of structure	1		2730	
Sync Cylinder	Mounted behind pump compartment	N/A		N/A	
Hose, 132	Pump to Jack, Left Front	2	Brown	2466	Measuring from inside of firewall, this is the end location of the hydraulic hoses where they attach to the slide mechanism.
Hose, 240	Pump to Jack, Left Rear	2	Orange	2475	
168	Pump to Jack, Right Front	2	White	2469	
Hose, 264	Pump to Jack, Right Rear	2	Yellow	2476	
Hose, N/A	Pump to sync cylinder	N/A	Green	N/A	Inside pump compartment
Hose, N/A	Sync cylinder to front slide, Room 1	N/A	Green	N/A	N/A
Hose, N/A	Sync cylinder to rear slide, Room 1	N/A	Green	N/A	N/A
Hose, 36	Pump to Room 1	2	Green	2458	127 / Drivers Side
Hose, 372	Pump to Room 2	2	Purple	2481	347 / Drivers Side
Hose w90, 372	Pump to Room 3	2	Gray	2481	307 / Passenger Side
Hose, N/A	Pump to Room 4	N/A	Red	N/A	N/A
Hose, N/A	Pump to Generator Slide	N/A	N/A	N/A	N/A
Travel Clamp	Two per Slide	N/A		N/A	N/A

Options

Revisions

1	Update per Equalizer Specs
2	Add Magellan to chart, same as Windsport per ECN 4582.

**34Y WINDSPORT (19.5) TIRES
EQUALIZER JACKS (FULLY AUTOMATIC)
STANDARD ON THIS UNIT**

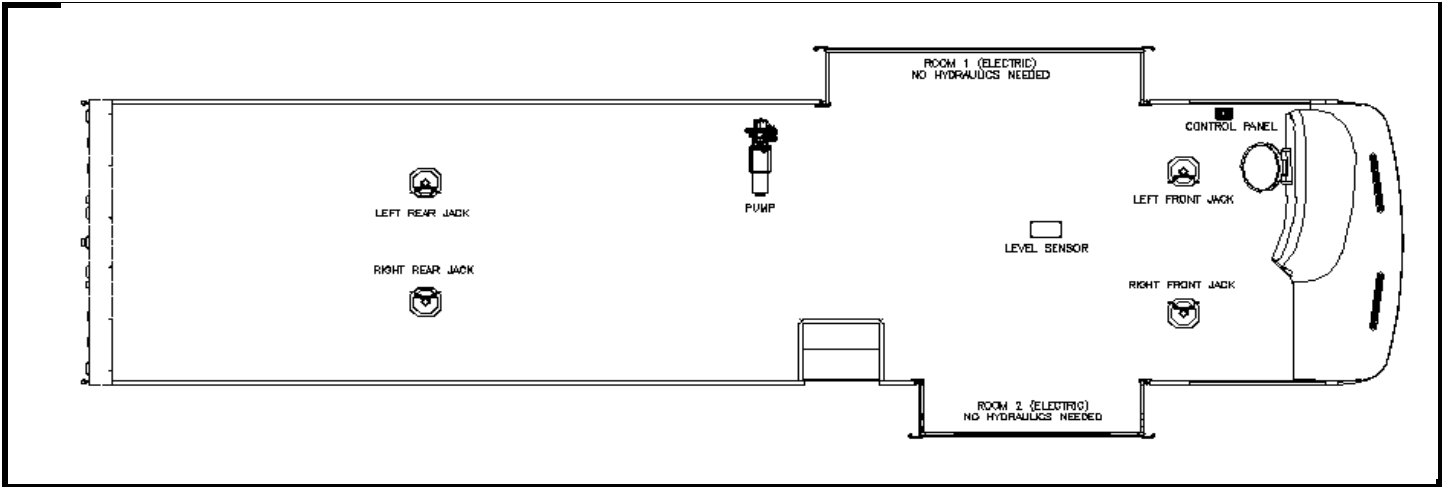

Notes:

1) Jacks mount 2nd hole from top to top mounting plate hole.

Item, Length	Description / Location	Qty	Color	Vendor PN		
Kit	(Items listed below)	1		8365	Measuring from back of cab floor, this is the end location of the hydraulic hoses where they attach to the slide mechanism.	
Pump	4-Function, Jacks Only	1		7239BR		
Jack	12,000 lbs, 16" Stroke	4		7214		
Touch Pad	Located to the left of the drivers seat	1		2318		
Control Box	Attached to bottom of structure	1		2730		
Sync Cylinder	Mounted behind pump compartment	N/A		N/A		
Hose, 180	Pump to Jack, Left Front	2	Brown	2470		
Hose, 180	Pump to Jack, Left Rear	2	Orange	2470		
Hose, 216	Pump to Jack, Right Front	2	White	2473		
Hose, 180	Pump to Jack, Right Rear	2	Yellow	2470		
Hose, N/A	Pump to Flow Divider	N/A	N/A	N/A		N/A
Hose, N/A	Flow divider to front slide, Room 1	N/A	N/A	N/A		N/A
Hose, N/A	Flow divider to rear slide, Room 1	N/A	N/A	N/A		N/A
Hose, N/A	Pump to Room 1	N/A	Green	N/A		N/A
Hose, N/A	Pump to Room 2	N/A	Purple	N/A		N/A
Hose, N/A	Pump to Room 3	N/A	Gray	N/A		N/A
Hose, N/A	Pump to Room 4	N/A	Red	N/A		N/A
Hose, N/A	Pump to Generator Slide	N/A	TBD	N/A		N/A
Travel Clamp	Two per Slide	N/A		HWH		N/A
Options						
Revisions						
1	Update per Equalizer Specs					

**36E WINDSPORT/MAGELLAN (22.5) TIRES
EQUALIZER JACKS (FULLY AUTOMATIC)
STANDARD ON THIS UNIT**

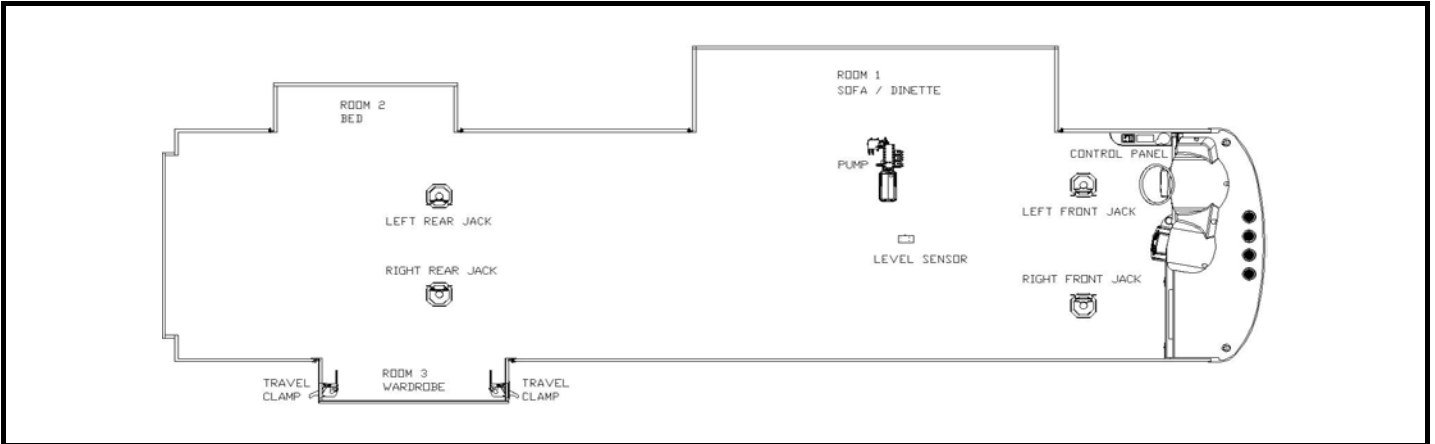

Notes:

1) Jacks mount in two different locations on bracket depending on tire size of chassis.

a) 19.5 Tires: Top hole in jack to top hole in bracket. Use 4 bolts in welded area of bracket.

b) 22.5 Tires: Top hole in jack to second hole in bracket. Use 6 bolts, 4 in welded area of bracket & 2 below welded area.

Item, Length	Description / Location	Qty	Color	Vendor PN	
Kit	(Items listed below)	1		8309	
Pump	7-Function, 3 Rooms & Jacks	1		7301BR	
Jack	12,000 lbs, 16" Stroke	4		7214	
Touch Pad	Located to the left of the drivers seat	1		2318	
Control Box	Attached to bottom of structure	1		2730	
Sync Cylinder	Mounted behind pump compartment	N/A		N/A	
Hose, 120	Pump to Jack, Left Front	2	Brown	2465	Measuring from inside of firewall, this is the end location of the hydraulic hoses where they attach to the slide mechanism.
Hose, 240	Pump to Jack, Left Rear	2	Orange	2475	
Hose, 168	Pump to Jack, Right Front	2	White	2469	
Hose, 252	Pump to Jack, Right Rear	2	Yellow	2587	
Hose, N/A	Pump to sync cylinder	N/A	Green	N/A	Inside pump compartment
Hose, N/A	Sync cylinder to front slide, Room 1	N/A	Green	N/A	N/A
Hose, N/A	Sync cylinder to rear slide, Room 1	N/A	Green	N/A	N/A
Hose, 36	Pump to Room 1	2	Green	2458	127 / Drivers Side
Hose, 372	Pump to Room 2	2	Purple	2481	319 / Drivers Side
Hose w/90, 372	Pump to Room 3	2	Gray	2481	319 / Passenger Side
Hose, N/A	Pump to Room 4	N/A	Red	N/A	N/A
Hose, N/A	Pump to Generator Slide	N/A	N/A	N/A	N/A
Travel Clamp	Two per Slide	2		HWH	N/A

Options

Revisions

1	New chart for Windsport for MY2007 due to Faux Flat on Rm 1, starting with the schedule released 04/24/06.
2	Update per Equalizer Specs

**36F WINDSPORT/MAGELLAN (22.5) TIRES
EQUALIZER JACKS (FULLY AUTOMATIC)
STANDARD ON THIS UNIT**

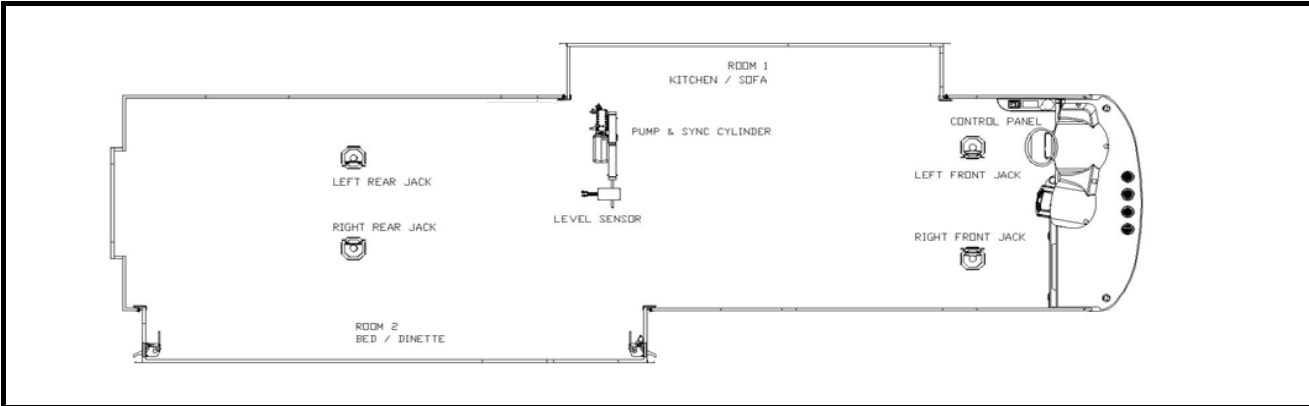

Notes:

- 1) Jacks mount in two different locations on bracket depending on tire size of chassis.
 - a) 19.5 Tires: Top hole in jack to top hole in bracket. Use 4 bolts in welded area of bracket.
 - b) 22.5 Tires: Top hole in jack to second hole in bracket. Use 6 bolts, 4 in welded area of bracket & 2 below welded area.
 - c) Hydraulic hose terminations for both rooms require 90 degree swivel elbows.

Item, Length	Description / Location	Qty	Color	Vendor PN	
Kit	(Items listed below)	1		8366	
Pump	6-Function, 2 Rooms & Jacks	1		7243BR	
Jack	12,000 lbs, 16" Stroke	4		7214	
Touch Pad	Located to the left of the drivers seat	1		2318	
Level Controller	Attached to bottom of structure	1		2730	
Sync Cylinder	Mounted inside pump compartment	1		7397	
Hose, 228	Pump to Jack, Left Front	2	Brown	2474	
Hose, 168	Pump to Jack, Left Rear	2	Orange	2469	
Hose, 264	Pump to Jack, Right Front	2	White	2476	
Hose, 204	Pump to Jack, Right Rear	2	Yellow	2472	
Hose, 36	Pump to sync cylinder	2	Purple	2458	Inside pump compartment
Hose w/90, 240	Sync cylinder to front slide, Room 2	2	Purple	2475	225 / Passenger Side
Hose w/90, 240	Sync cylinder to rear slide, Room 2	2	Purple	2475	371 / Passenger Side
Slide Unit	Room 2 - 24" flush floor slide (angled)	2		7388	
Hose w/90, 120	Pump to Room 1	2	Green	2465	135 / Drivers Side
Slide Unit	Room 1 - 24" above floor slide	1		7369	
Hose, N/A	Pump to Room 2	N/A	Purple	N/A	N/A
Hose, N/A	Pump to Room 3	N/A	Gray	N/A	N/A
Hose, N/A	Pump to Room 4	N/A	Red	N/A	N/A
Hose, N/A	Pump to Generator Slide	N/A		N/A	N/A
Travel Clamp	Two per Slide	2		HWH	N/A

Measuring from inside of firewall, this is the end location of the hydraulic hoses where they attach to the slide mechanism.

Options

Revisions

1	Update per Equalizer Specs
2	Add Magellan to usage in header per ECN 4582

**36R WINDSPORT/MAGELLAN (22.5) TIRES
EQUALIZER JACKS (FULLY AUTOMATIC)
STANDARD ON THIS UNIT**

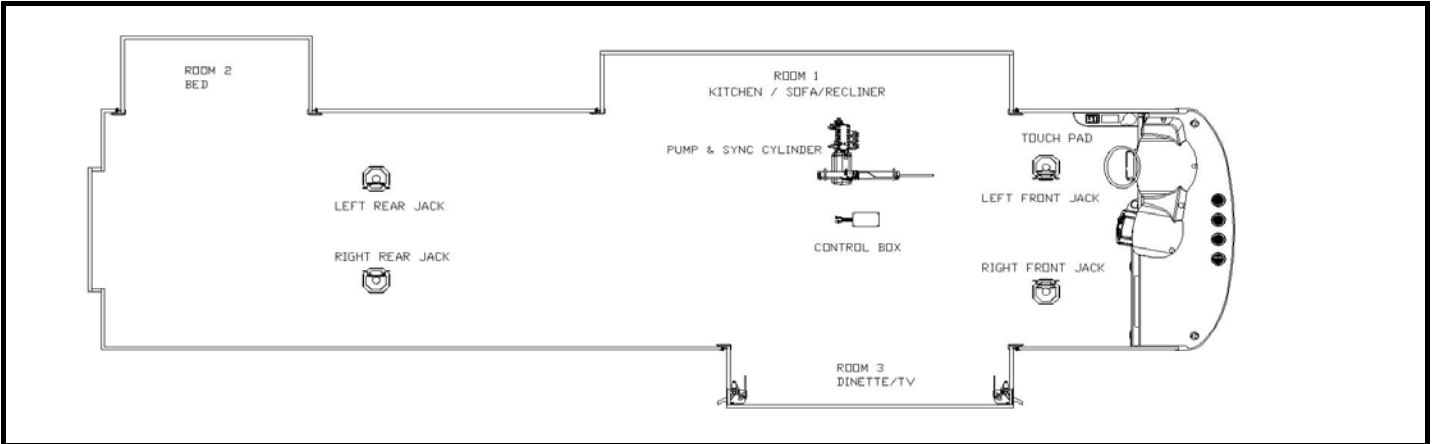

Notes:

- 1) Jacks mount in two different locations on bracket depending on tire size of chassis.
 - a) 19.5 Tires: Top hole in jack to top hole in bracket. Use 4 bolts in welded area of bracket.
 - b) 22.5 Tires: Top hole in jack to second hole in bracket. Use 6 bolts, 4 in welded area of bracket & 2 below welded area.
 - c) Hydraulic hose terminations for room #3 require 90 degree swivel elbows.

Item, Length	Description / Location	Qty	Color	Vendor PN		
Kit	(Items listed below)	1		8342	Measuring from inside of firewall, this is the end location of the hydraulic hoses where they attach to the slide mechanism.	
Pump	7-Function, 3 Rooms & Jacks	1		7301BR		
Jack	12,000 lbs, 16" Stroke	4		7214		
Touch Pad	Located to the left of the drivers seat	1		2318		
Control Box	Attached to bottom of structure	1		2730		
Sync Cylinder	Mounted behind pump compartment	1		7397		
Hose, 120	Pump to Jack, Left Front	2	Brown	2465		
Hose, 240	Pump to Jack, Left Rear	2	Orange	2475		
Hose, 168	Pump to Jack, Right Front	2	White	2469		
Hose, 240	Pump to Jack, Right Rear	2	Yellow	2475		
Hose, 36	Pump to sync cylinder	2	Gray	2458		Inside pump compartment
Hose, 120	Sync cylinder to front slide, Room 3	2	Gray	2465		90 / Passenger Side
Hose, 120	Sync cylinder to rear slide, Room 3	2	Gray	2465		145 / Passenger Side
Hose, 36	Pump to Room 1	2	Green	2458		127 / Drivers Side
Hose, 420	Pump to Room 2	2	Purple	2485		335 / Drivers Side
Hose, N/A	Pump to Room 3	N/A	Gray	N/A		N/A
Hose, N/A	Pump to Room 4	N/A	Red	N/A	N/A	
Hose, N/A	Pump to Generator Slide	N/A		N/A	N/A	
Travel Clamp	Two per Slide	2		HWH	N/A	

Options

Revisions

1	Update per Equalizer Specs
2	Add Magellan to usage in header per ECN 4582

**36Z WINDSPORT/MAGELLAN (22.5) TIRES
EQUALIZER JACKS (FULLY AUTOMATIC)
STANDARD ON THIS UNIT**

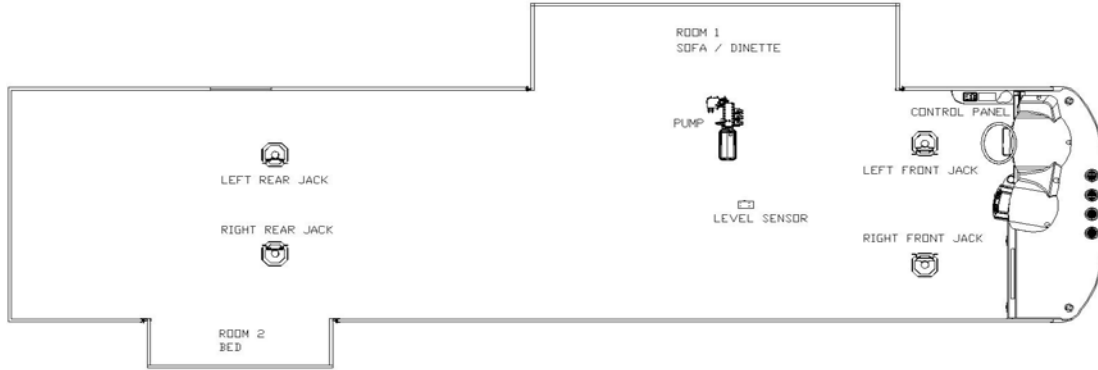

Notes:

1) Jacks mount in two different locations on bracket depending on tire size of chassis.

a) 19.5 Tires: Top hole in jack to top hole in bracket. Use 4 bolts in welded area of bracket.

b) 22.5 Tires: Top hole in jack to second hole in bracket. Use 6 bolts, 4 in welded area of bracket & 2 below welded area.

Item, Length	Description / Location	Qty	Color	Vendor PN	
Kit	(Items listed below)	1		8307	
Pump	6-Function, 2 Rooms & Jacks	1		7243BR	
Jack	12,000 lbs, 16" Stroke	4		7214	
Touch Pad	Located to the left of the drivers seat	1		2318	
Control Box	Attached to bottom of structure	1		2730	
Sync Cylinder	Mounted behind pump compartment	N/A		N/A	
Hose, 120	Pump to Jack, Left Front	2	Brown	2465	Measuring from inside of firewall, this is the end location of the hydraulic hoses where they attach to the slide mechanism.
Hose, 228	Pump to Jack, Left Rear	2	Orange	2474	
Hose, 156	Pump to Jack, Right Front	2	White	2468	
Hose, 252	Pump to Jack, Right Rear	2	Yellow	2587	
Hose, N/A	Pump to sync cylinder	N/A	Green	N/A	
Hose, N/A	Sync cylinder to front slide, Room 1	N/A	Green	N/A	N/A
Hose, N/A	Sync cylinder to rear slide, Room 1	N/A	Green	N/A	N/A
Hose, 36	Pump to Room 1	2	Green	2458	127 / Drivers Side
Hose, 372	Pump to Room 2	2	Purple	2481	319 / Passenger Side
Hose, N/A	Pump to Room 3	N/A	Gray	N/A	N/A
Hose, N/A	Pump to Room 4	N/A	Red	N/A	N/A
Hose, N/A	Pump to Generator Slide	N/A	N/A	N/A	N/A
Travel Clamp	Two per Slide	N/A		HWH	N/A

Options

Revisions

1	New chart for Windsport for MY2007 due to Faux Flat on Rm 1, starting with the schedule released 04/24/06.
2	Update per Equalizer Specs
3	Add Magellan to usage in header per ECN 4582

**30Q HURRICANE/WINDSPORT (19.5) TIRES
EQUALIZER JACKS (FULLY AUTOMATIC)
OPTIONAL ON THIS UNIT**



Notes:

1) Jacks mount in two different locations on bracket depending on tire size of chassis.

a) 19.5 Tires: Top hole in jack to top hole in bracket. Use 4 bolts in welded area of bracket.

b) 22.5 Tires: Top hole in jack to second hole in bracket. Use 6 bolts, 4 in welded area of bracket & 2 below welded area.

Item, Length	Description / Location	Qty	Color	Vendor PN		
Kit	(Items listed below)	1		8252	Measuring from inside of firewall, this is the end location of the hydraulic hoses where they attach to the slide mechanism.	
Pump	4-Function, Jacks	1		7239BR		
Jack	12,000 lbs, 16" Stroke	4		7214		
Touch Pad	Located to the left of the drivers seat	1		2318		
Control Box	Attached to bottom of structure	1		2730		
Flow Divider	Mounted inside pump compartment	N/A		N/A		
Hose, 132	Pump to Jack, Left Front	2	Brown	2466		
Hose, 216	Pump to Jack, Left Rear	2	Orange	2473		
Hose, 180	Pump to Jack, Right Front	1	White	2470		
Hose, 264	Pump to Jack, Right Rear	1	Yellow	2476		
Hose, 96	Left Front Jack, Right Front Jack	1	Whi/Brn.	2463		
Hose, 96	Left Rear Jack, Right Rear Jack	1	Yel/Ora.	2463		
Hose, N/A	Pump to Flow Divider	N/A	Green	N/A		N/A
Hose, N/A	Flow divider to front slide, Room 1	N/A	Green	N/A		N/A
Hose, N/A	Flow divider to rear slide, Room 1	N/A	Green	N/A	N/A	
Hose, N/A	Pump to Room 1	N/A	Green	N/A	N/A	
Hose, N/A	Pump to Room 2	N/A	Purple	N/A	N/A	
Hose, N/A	Pump to Room 3	N/A	Gray	N/A	N/A	
Hose, N/A	Pump to Room 4	N/A	Red	N/A	N/A	
Hose, N/A	Pump to Generator Slide	N/A		N/A	N/A	
Travel Clamp	Two per Slide	N/A		HWH	N/A	

Options

Revisions

1	Add Windsport to Title of this chart for MY2007.
2	Update per Equalizer Specs

**31D HURRICANE/WINDSPORT (19.5) TIRES
EQUALIZER JACKS (FULLY AUTOMATIC)
OPTIONAL ON THIS UNIT**

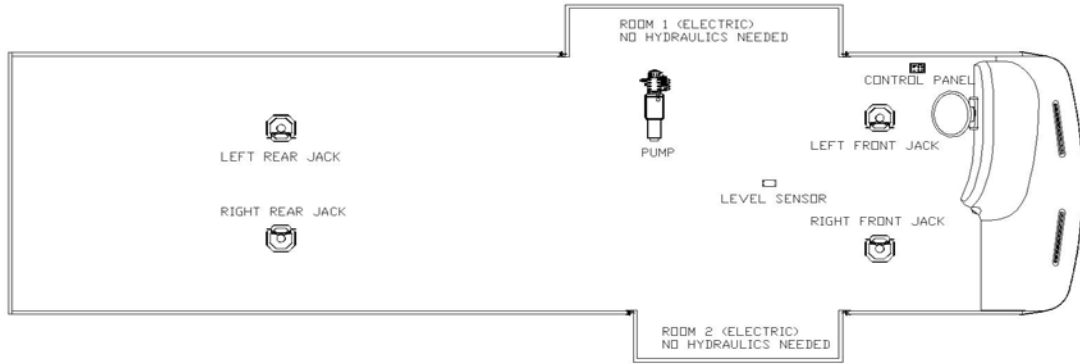

Notes:

- 1) Jacks mount in two different locations on bracket depending on tire size of chassis.
 - a) 19.5 Tires: Top hole in jack to top hole in bracket. Use 4 bolts in welded area of bracket.
 - b) 22.5 Tires: Top hole in jack to second hole in bracket. Use 6 bolts, 4 in welded area of bracket & 2 below welded area.

Item, Length	Description / Location	Qty	Color	Vendor PN		
Kit	(Items listed below)	1		8252	Measuring from inside of firewall, this is the end location of the hydraulic hoses where they attach to the slide mechanism.	
Pump	4-Function, Jacks	1		7239BR		
Jack	12,000 lbs, 16" Stroke	4		7214		
Touch Pad	Located to the left of the drivers seat	1		2318		
Control Box	Attached to bottom of structure	1		2730		
Flow Divider	Mounted inside pump compartment	N/A		N/A		
Hose, 132	Pump to Jack, Left Front	2	Brown	2466		
Hose, 216	Pump to Jack, Left Rear	2	Orange	2473		
Hose, 180	Pump to Jack, Right Front	1	White	2470		
Hose, 264	Pump to Jack, Right Rear	1	Yellow	2476		
Hose, 96	Left Front Jack, Right Front Jack	1	Whi/Brn.	2463		
Hose, 96	Left Rear Jack, Right Rear Jack	1	Yel/Ora.	2463		
Hose, N/A	Pump to Flow Divider	N/A	Green	N/A		N/A
Hose, N/A	Flow divider to front slide, Room 1	N/A	Green	N/A		N/A
Hose, N/A	Flow divider to rear slide, Room 1	N/A	Green	N/A	N/A	
Hose, N/A	Pump to Room 1	N/A	Green	N/A	N/A	
Hose, N/A	Pump to Room 2	N/A	Purple	N/A	N/A	
Hose, N/A	Pump to Room 3	N/A	Gray	N/A	N/A	
Hose, N/A	Pump to Room 4	N/A	Red	N/A	N/A	
Hose, N/A	Pump to Generator Slide	N/A		N/A	N/A	
Travel Clamp	Two per Slide	N/A		HWH	N/A	

Options

Revisions

1	Add Windsport to Title of this chart for MY2007.
2	Update per Equalizer Specs

**32E HURRICANE/WINDSPORT (19.5) TIRES
EQUALIZER JACKS (FULLY AUTOMATIC)
OPTIONAL ON THIS UNIT**

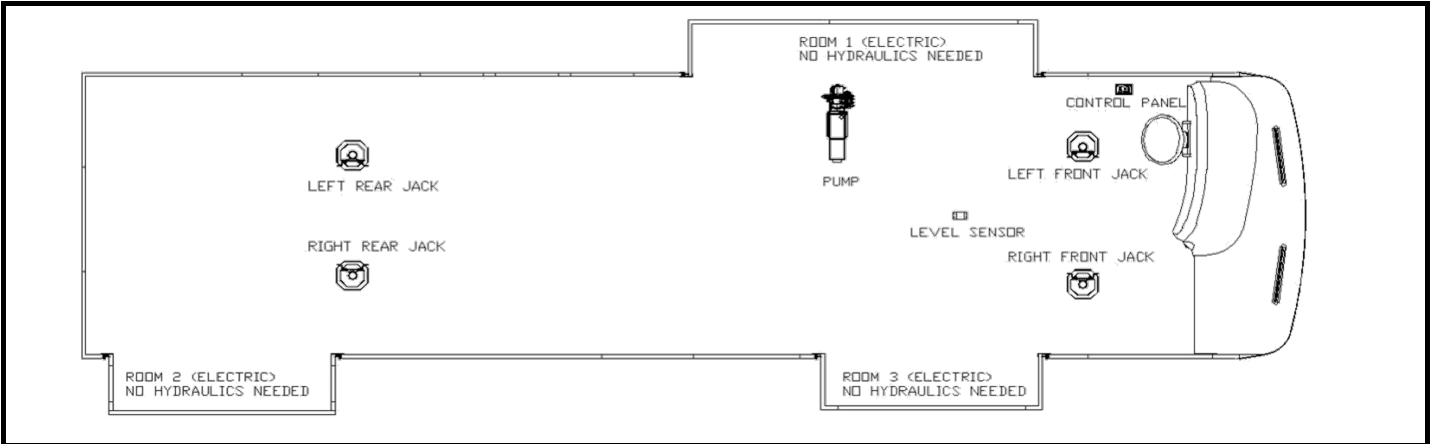

Notes:

- 1) Jacks mount in two different locations on bracket depending on tire size of chassis.
 - a) 19.5 Tires: Top hole in jack to top hole in bracket. Use 4 bolts in welded area of bracket.
 - b) 22.5 Tires: Top hole in jack to second hole in bracket. Use 6 bolts, 4 in welded area of bracket & 2 below welded area.

Item, Length	Description / Location	Qty	Color	Vendor PN		
Kit	(Items listed below)	1		8252	Measuring from inside of firewall, this is the end location of the hydraulic hoses where they attach to the slide mechanism.	
Pump	4-Function, Jacks	1		7239BR		
Jack	12,000 lbs, 16" Stroke	4		7214		
Touch Pad	Located to the left of the drivers seat	1		2318		
Control Box	Attached to bottom of structure	1		2730		
Flow Divider	Mounted inside pump compartment	N/A		N/A		
Hose, 132	Pump to Jack, Left Front	2	Brown	2466		
Hose, 216	Pump to Jack, Left Rear	2	Orange	2473		
Hose, 180	Pump to Jack, Right Front	1	White	2470		
Hose, 264	Pump to Jack, Right Rear	1	Yellow	2476		
Hose, 96	Left Front Jack, Right Front Jack	1	Whi/Brn.	2463		
Hose, 96	Left Rear Jack, Right Rear Jack	1	Yel/Ora.	2463		
Hose, N/A	Pump to Flow Divider	N/A	Green	N/A		N/A
Hose, N/A	Flow divider to front slide, Room 1	N/A	Green	N/A		N/A
Hose, N/A	Flow divider to rear slide, Room 1	N/A	Green	N/A		N/A
Hose, N/A	Pump to Room 1	N/A	Green	N/A	N/A	
Hose, N/A	Pump to Room 2	N/A	Purple	N/A	N/A	
Hose, N/A	Pump to Room 3	N/A	Gray	N/A	N/A	
Hose, N/A	Pump to Room 4	N/A	Red	N/A	N/A	
Hose, N/A	Pump to Generator Slide	N/A		N/A	N/A	
Travel Clamp	Two per Slide	N/A		HWH	N/A	

Options

Revisions

1	Update per Equalizer Specs

**33H HURRICANE (19.5) TIRES
EQUALIZER JACKS (FULLY AUTOMATIC)
STANDARD ON THIS UNIT**

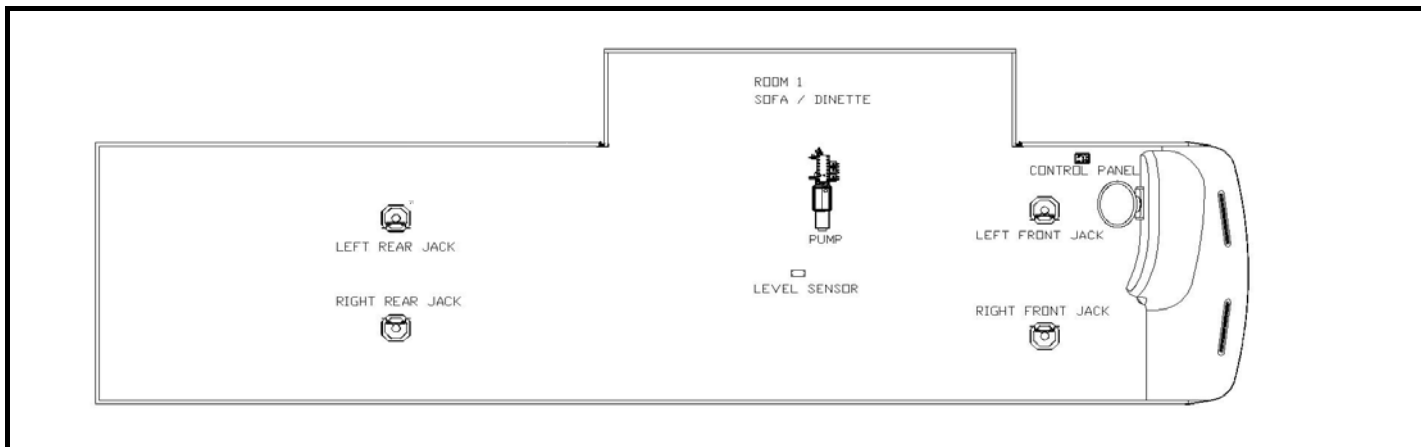

Notes:

1) Jacks mount in two different locations on bracket depending on tire size of chassis.

a) 19.5 Tires: Top hole in jack to top hole in bracket. Use 4 bolts in welded area of bracket.

b) 22.5 Tires: Top hole in jack to second hole in bracket. Use 6 bolts, 4 in welded area of bracket & 2 below welded area.

Item, Length	Description / Location	Qty	Color	Vendor PN	
Kit	(Items listed below)	1		8270	
Pump	5-Function, 1 Room, Jacks	1		7242BR	
Jack	12,000 lbs, 16" Stroke	4		7214	
Touch Pad	Located to the left of the drivers seat	1		2318	
Control Box	Attached to bottom of structure	1		2730	
Flow Divider	Mounted inside pump compartment	N/A		N/A	
Hose, 132	Pump to Jack, Left Front	2	Brown	2466	
Hose, 216	Pump to Jack, Left Rear	2	Orange	2473	
Hose, 180	Pump to Jack, Right Front	1	White	2470	
Hose, 264	Pump to Jack, Right Rear	1	Yellow	2476	
Hose, 96	Left Front Jack, Right Front Jack	1	Whi/Brn.	2463	
Hose, 96	Left Rear Jack, Right Rear Jack	1	Yel/Ora.	2463	
Hose, N/A	Pump to Flow Divider	N/A	Green	N/A	N/A
Hose, N/A	Flow divider to front slide, Room 1	N/A	Green	N/A	N/A
Hose, N/A	Flow divider to rear slide, Room 1	N/A	Green	N/A	N/A
Hose, 36	Pump to Room 1	2	Green	2458	127 / Drivers Side
Slide Unit	Room 1-36" Above floor slide	1		7164	
Hose, N/A	Pump to Room 2	N/A	Purple	N/A	N/A
Slide Unit					
Hose, N/A	Pump to Room 3	N/A	Gray	N/A	N/A
Slide Unit					
Hose, N/A	Pump to Room 4	N/A	Red	N/A	N/A
Slide Unit					
Travel Clamp	Two per Slide	N/A		HWH	N/A

Measuring from inside of firewall, this is the end location of the hydraulic hoses where they attach to the slide mechanism.

Options

Revisions

1	Update per Equalizer Specs				

**33T HURRICANE (19.5) TIRES
EQUALIZER JACKS (FULLY AUTOMATIC)
STANDARD ON THIS UNIT**

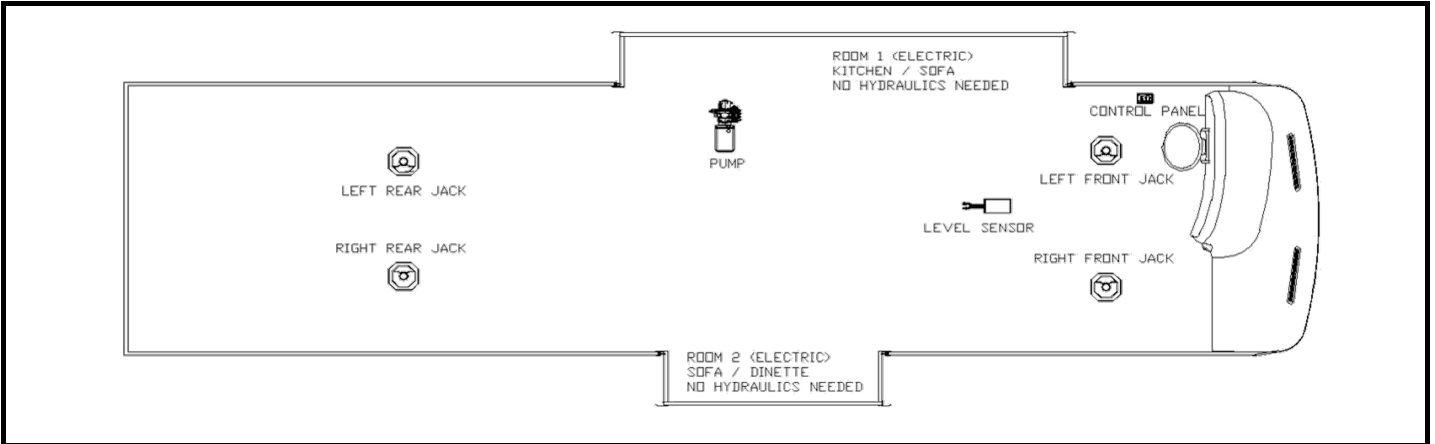

Notes:

- 1) Jacks mount in two different locations on bracket depending on tire size of chassis.
 - a) 19.5 Tires: Top hole in jack to top hole in bracket. Use 4 bolts in welded area of bracket.
 - b) 22.5 Tires: Top hole in jack to second hole in bracket. Use 6 bolts, 4 in welded area of bracket & 2 below welded area.

Item, Length	Description / Location	Qty	Color	Vendor PN		
Kit	(Items listed below)	1		8381	Measuring from inside of firewall, this is the end location of the hydraulic hoses where they attach to the slide mechanism.	
Pump	4-Function, Jacks	1		7239BR		
Jack	12,000 lbs, 16" Stroke	4		7214		
Touch Pad	Located to the left of the drivers seat	1		2318		
Control Box	Attached to bottom of structure	1		2730		
Flow Divider	Mounted inside pump compartment	N/A		N/A		
Hose, 204	Pump to Jack, Left Front	2	Brown	2472		
Hose, 180	Pump to Jack, Left Rear	2	Orange	2470		
Hose, 252	Pump to Jack, Right Front	1	White	2587		
Hose, 216	Pump to Jack, Right Rear	1	Yellow	2473		
Hose, 96	Left Front Jack, Right Front Jack	1	Whi/Brn.	2463		
Hose, 96	Left Rear Jack, Right Rear Jack	1	Yel/Ora.	2463		
Hose, N/A	Pump to Flow Divider	N/A	N/A	N/A		N/A
Hose, N/A	Flow divider to front slide, Room 1	N/A	N/A	N/A		N/A
Hose, N/A	Flow divider to rear slide, Room 1	N/A	N/A	N/A		N/A
Hose, N/A	Pump to Room 1	N/A	Green	N/A	N/A	
Hose, N/A	Pump to Room 2	N/A	Purple	N/A	N/A	
Hose, N/A	Pump to Room 3	N/A	Gray	N/A	N/A	
Hose, N/A	Pump to Room 4	N/A	Red	N/A	N/A	
Hose, N/A	Pump to Generator Slide	N/A	TBD	N/A	N/A	
Travel Clamp	Two per Slide	N/A		HWH	N/A	

Options

Revisions

**34B HURRICANE (19.5) TIRES
EQUALIZER JACKS (FULLY AUTOMATIC)
STANDARD ON THIS UNIT**

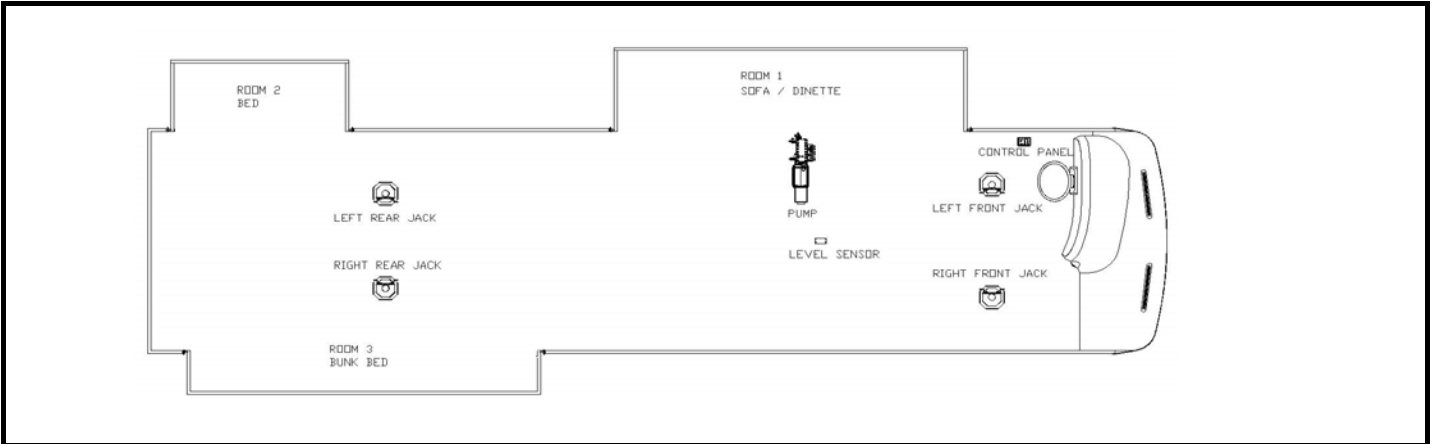

Notes:

- 1) Jacks mount in two different locations on bracket depending on tire size of chassis.
 - a) 19.5 Tires: Top hole in jack to top hole in bracket. Use 4 bolts in welded area of bracket.
 - b) 22.5 Tires: Top hole in jack to second hole in bracket. Use 6 bolts, 4 in welded area of bracket & 2 below welded area.

Item, Length	Description / Location	Qty	Color	Vendor PN	
Kit	(Items listed below)	1		8323	
Pump	7-Function, 3 Rooms, Jacks	1		7301BR	
Jack	12,000 lbs, 16" Stroke	4		7214	
Touch Pad	Located to the left of the drivers seat	1		2318	
Control Box	Attached to bottom of structure	1		2730	
Flow Divider	Mounted inside pump compartment	N/A		N/A	
Hose, 132	Pump to Jack, Left Front	2	Brown	2466	
Hose, 240	Pump to Jack, Left Rear	2	Orange	2475	
Hose, 168	Pump to Jack, Right Front	2	White	2469	
Hose, 264	Pump to Jack, Right Rear	1	Yellow	2476	
Hose, 96	Left Rear Jack, Right Rear Jack	1	Yel/Ora.	2463	
Hose, 36	Pump to Room 1	2	Green	2458	127 / Drivers Side
Slide Unit	Room 1-36" Above Floor Slide	1		7164	
Hose, 372	Pump to Room 2	2	Purple	2481	347 / Drivers Side
Slide Unit	Room 2-30" Bed Slide(Lipper)	1		134998	
Hose w90, 372	Pump to Room 3	2	Gray	2481	307 / Passenger Side
Slide Unit	Room 3-18" Above floor slide	1		7135	
Hose, N/A	Pump to Room 4	N/A	Red	N/A	N/A
Travel Clamp	Two per Slide	N/A		N/A	N/A

Measuring from inside of firewall, this is the end location of the hydraulic hoses where they attach to the slide mechanism.

Options

Revisions

9/1/2006	Add 34S to 34B chart
2	Update per Equalizer Specs

**34N HURRICANE (19.5) TIRES
EQUALIZER JACKS (FULLY AUTOMATIC)
STANDARD ON THIS UNIT**

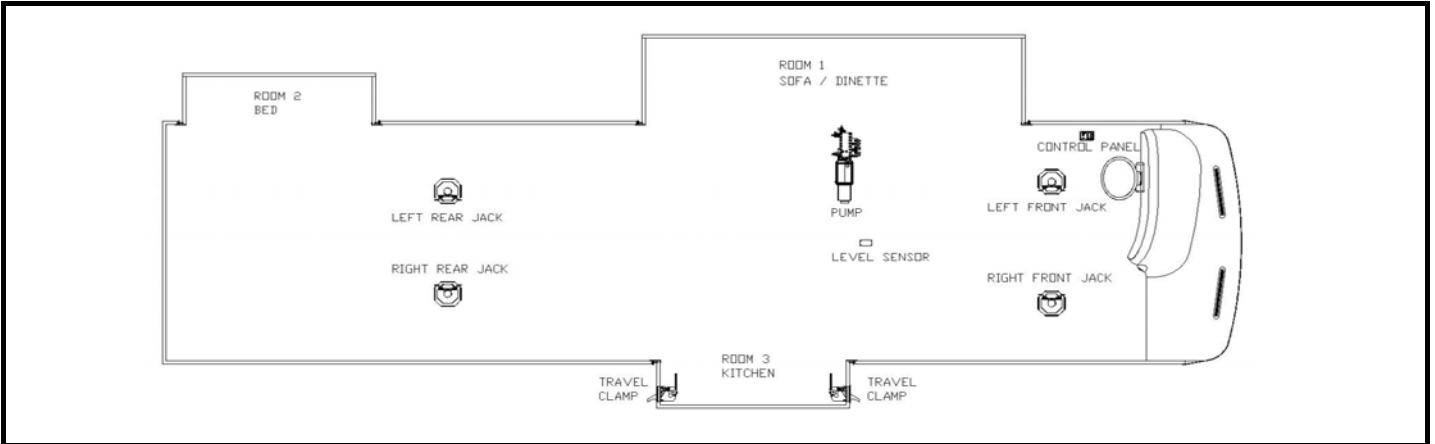

Notes:

1) Jacks mount in two different locations on bracket depending on tire size of chassis.

a) 19.5 Tires: Top hole in jack to top hole in bracket. Use 4 bolts in welded area of bracket.

b) 22.5 Tires: Top hole in jack to second hole in bracket. Use 6 bolts, 4 in welded area of bracket & 2 below welded area.

Item, Length	Description / Location	Qty	Color	Vendor PN	
Kit	(Items listed below)	1		8269	
Pump	7-Function, 3 Rooms, Jacks	1		7301BR	
Jack	12,000 lbs, 16" Stroke	4		7214	
Touch Pad	Located to the left of the drivers seat	1		2318	
Control Box	Attached to bottom of structure	1		2730	
Flow Divider	Mounted inside pump compartment	N/A		N/A	
Hose, 132	Pump to Jack, Left Front	2	Brown	2466	
Hose, 216	Pump to Jack, Left Rear	2	Orange	2473	
Hose, 180	Pump to Jack, Right Front	2	White	2470	
Hose, 264	Pump to Jack, Right Rear	1	Yellow	2476	
Hose, 96	Left Rear Jack, Right Rear Jack	1	Yel/Ora.	2463	
Hose, N/A	Pump to Flow Divider	N/A	Green	N/A	N/A
Hose, N/A	Flow divider to rear slide, Room 1	N/A	Green	N/A	N/A
Hose, N/A	Flow divider to front slide, Room 1	N/A	Green	N/A	N/A
Hose, 36	Pump to Room 1	2	Green	2458	127 / Drivers Side
Slide Unit	Room 1-36" Above Floor Slide	1		7164	
Hose, 372	Pump to Room 2	2	Purple	2481	305 / Passenger Side
Slide Unit	Room 2-30" Bed slide (Lippert)	1		134998	
Hose w90, 108	Pump to Room 3	2	Gray	2464	160 / Passenger Side
Slide Unit	Room 3-18" Above floor slide	1		7135	
Hose, N/A	Pump to Room 4	N/A	Red	N/A	N/A
Slide Unit					
Travel Clamp	Two per Slide	2		HWH	N/A

Measuring from inside of firewall, this is the end location of the hydraulic hoses where they attach to the slide mechanism.

Options

Revisions

1	Update per Equalizer Specs

**34Y HURRICANE (19.5) TIRES
EQUALIZER JACKS (FULLY AUTOMATIC)
STANDARD ON THIS UNIT**

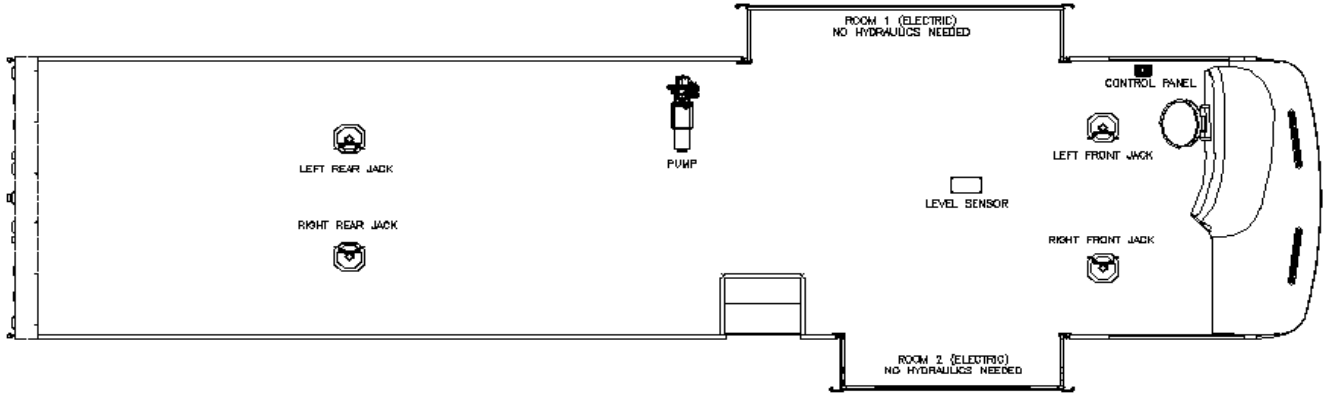

Notes:

1) Jacks mount 2nd hole from top to top mounting plate hole.

Item, Length	Description / Location	Qty	Color	Vendor PN		
Kit	(Items listed below)	1		8365	Measuring from back of cab floor, this is the end location of the hydraulic hoses where they attach to the slide mechanism.	
Pump	4-Function, Jacks Only	1		7239BR		
Jack	12,000 lbs, 16" Stroke	4		7214		
Touch Pad	Located to the left of the drivers seat	1		2318		
Control Box	Attached to bottom of structure	1		2730		
Flow Divider	Mounted inside pump compartment	N/A		N/A		
Hose, 180	Pump to Jack, Left Front	2	Brown	2470		
Hose, 180	Pump to Jack, Left Rear	2	Orange	2470		
Hose, 216	Pump to Jack, Right Front	1	White	2473		
Hose, 180	Pump to Jack, Right Rear	1	Yellow	2470		
Hose, 96	Left Front Jack, Right Front Jack	1	Whi/Brn.	2463		
Hose, 96	Left Rear Jack, Right Rear Jack	1	Yel/Ora.	2463		
Hose, N/A	Pump to Flow Divider	N/A	N/A	N/A		N/A
Hose, N/A	Flow divider to front slide, Room 1	N/A	N/A	N/A		N/A
Hose, N/A	Flow divider to rear slide, Room 1	N/A	N/A	N/A		N/A
Hose, N/A	Pump to Room 1	N/A	Green	N/A		N/A
Hose, N/A	Pump to Room 2	N/A	Purple	N/A		N/A
Hose, N/A	Pump to Room 3	N/A	Gray	N/A		N/A
Hose, N/A	Pump to Room 4	N/A	Red	N/A		N/A
Hose, N/A	Pump to Generator Slide	N/A	TBD	N/A		N/A
Travel Clamp	Two per Slide	N/A		HWH	N/A	
Options						

Revisions

1	Update per Equalizer Specs			

**30Q HURRICANE/WINDSPORT (19.5) TIRES
EQUALIZER JACKS (FULLY AUTOMATIC)
OPTIONAL ON THIS UNIT**



Notes:

1) Jacks mount in two different locations on bracket depending on tire size of chassis.

a) 19.5 Tires: Top hole in jack to top hole in bracket. Use 4 bolts in welded area of bracket.

b) 22.5 Tires: Top hole in jack to second hole in bracket. Use 6 bolts, 4 in welded area of bracket & 2 below welded area.

Item, Length	Description / Location	Qty	Color	Vendor PN		
Kit	(Items listed below)	1		8252	Measuring from inside of firewall, this is the end location of the hydraulic hoses where they attach to the slide mechanism.	
Pump	4-Function, Jacks	1		7239BR		
Jack	12,000 lbs, 16" Stroke	4		7214		
Touch Pad	Located to the left of the drivers seat	1		2318		
Control Box	Attached to bottom of structure	1		2730		
Flow Divider	Mounted inside pump compartment	N/A		N/A		
Hose, 132	Pump to Jack, Left Front	2	Brown	2466		
Hose, 216	Pump to Jack, Left Rear	2	Orange	2473		
Hose, 180	Pump to Jack, Right Front	1	White	2470		
Hose, 264	Pump to Jack, Right Rear	1	Yellow	2476		
Hose, 96	Left Front Jack, Right Front Jack	1	Whi/Brn.	2463		
Hose, 96	Left Rear Jack, Right Rear Jack	1	Yel/Ora.	2463		
Hose, N/A	Pump to Flow Divider	N/A	Green	N/A		N/A
Hose, N/A	Flow divider to front slide, Room 1	N/A	Green	N/A		N/A
Hose, N/A	Flow divider to rear slide, Room 1	N/A	Green	N/A	N/A	
Hose, N/A	Pump to Room 1	N/A	Green	N/A	N/A	
Hose, N/A	Pump to Room 2	N/A	Purple	N/A	N/A	
Hose, N/A	Pump to Room 3	N/A	Gray	N/A	N/A	
Hose, N/A	Pump to Room 4	N/A	Red	N/A	N/A	
Hose, N/A	Pump to Generator Slide	N/A		N/A	N/A	
Travel Clamp	Two per Slide	N/A		HWH	N/A	

Options

Revisions

1	Add Windsport to Title of this chart for MY2007.
2	Update per Equalizer Specs

**31D HURRICANE/WINDSPORT (19.5) TIRES
EQUALIZER JACKS (FULLY AUTOMATIC)
OPTIONAL ON THIS UNIT**

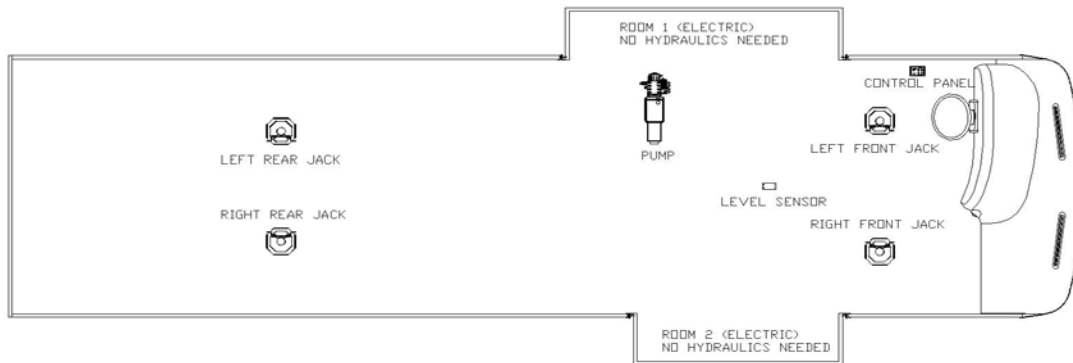

Notes:

1) Jacks mount in two different locations on bracket depending on tire size of chassis.

a) 19.5 Tires: Top hole in jack to top hole in bracket. Use 4 bolts in welded area of bracket.

b) 22.5 Tires: Top hole in jack to second hole in bracket. Use 6 bolts, 4 in welded area of bracket & 2 below welded area.

Item, Length	Description / Location	Qty	Color	Vendor PN		
Kit	(Items listed below)	1		8252		
Pump	4-Function, Jacks	1		7239BR		
Jack	12,000 lbs, 16" Stroke	4		7214		
Touch Pad	Located to the left of the drivers seat	1		2318		
Control Box	Attached to bottom of structure	1		2730		
Flow Divider	Mounted inside pump compartment	N/A		N/A		
Hose, 132	Pump to Jack, Left Front	2	Brown	2466	Measuring from inside of firewall, this is the end location of the hydraulic hoses where they attach to the slide mechanism.	
Hose, 216	Pump to Jack, Left Rear	2	Orange	2473		
Hose, 180	Pump to Jack, Right Front	1	White	2470		
Hose, 264	Pump to Jack, Right Rear	1	Yellow	2476		
Hose, 96	Left Front Jack, Right Front Jack	1	Whi/Brn.	2463		
Hose, 96	Left Rear Jack, Right Rear Jack	1	Yel/Ora.	2463		
Hose, N/A	Pump to Flow Divider	N/A	Green	N/A		N/A
Hose, N/A	Flow divider to front slide, Room 1	N/A	Green	N/A		N/A
Hose, N/A	Flow divider to rear slide, Room 1	N/A	Green	N/A		N/A
Hose, N/A	Pump to Room 1	N/A	Green	N/A		N/A
Hose, N/A	Pump to Room 2	N/A	Purple	N/A	N/A	
Hose, N/A	Pump to Room 3	N/A	Gray	N/A	N/A	
Hose, N/A	Pump to Room 4	N/A	Red	N/A	N/A	
Hose, N/A	Pump to Generator Slide	N/A		N/A	N/A	
Travel Clamp	Two per Slide	N/A		HWH	N/A	

Options

Revisions

1	Add Windsport to Title of this chart for MY2007.
2	Update per Equalizer Specs

**32E HURRICANE/WINDSPORT (19.5) TIRES
EQUALIZER JACKS (FULLY AUTOMATIC)
OPTIONAL ON THIS UNIT**

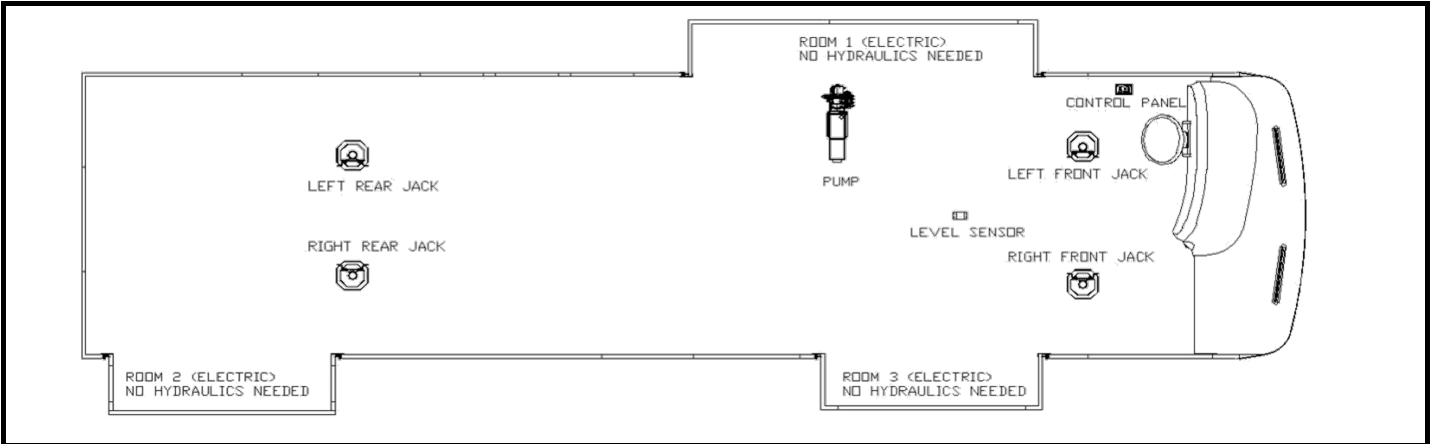

Notes:

1) Jacks mount in two different locations on bracket depending on tire size of chassis.

a) 19.5 Tires: Top hole in jack to top hole in bracket. Use 4 bolts in welded area of bracket.

b) 22.5 Tires: Top hole in jack to second hole in bracket. Use 6 bolts, 4 in welded area of bracket & 2 below welded area.

Item, Length	Description / Location	Qty	Color	Vendor PN	
Kit	(Items listed below)	1		8252	
Pump	4-Function, Jacks	1		7239BR	
Jack	12,000 lbs, 16" Stroke	4		7214	
Touch Pad	Located to the left of the drivers seat	1		2318	
Control Box	Attached to bottom of structure	1		2730	
Flow Divider	Mounted inside pump compartment	N/A		N/A	
Hose, 132	Pump to Jack, Left Front	2	Brown	2466	
Hose, 216	Pump to Jack, Left Rear	2	Orange	2473	
Hose, 180	Pump to Jack, Right Front	1	White	2470	
Hose, 264	Pump to Jack, Right Rear	1	Yellow	2476	
Hose, 96	Left Front Jack, Right Front Jack	1	Whi/Brn.	2463	
Hose, 96	Left Rear Jack, Right Rear Jack	1	Yel/Ora.	2463	
Hose, N/A	Pump to Flow Divider	N/A	Green	N/A	N/A
Hose, N/A	Flow divider to front slide, Room 1	N/A	Green	N/A	N/A
Hose, N/A	Flow divider to rear slide, Room 1	N/A	Green	N/A	N/A
Hose, N/A	Pump to Room 1	N/A	Green	N/A	N/A
Hose, N/A	Pump to Room 2	N/A	Purple	N/A	N/A
Hose, N/A	Pump to Room 3	N/A	Gray	N/A	N/A
Hose, N/A	Pump to Room 4	N/A	Red	N/A	N/A
Hose, N/A	Pump to Generator Slide	N/A		N/A	N/A
Travel Clamp	Two per Slide	N/A		HWH	N/A

Measuring from inside of firewall, this is the end location of the hydraulic hoses where they attach to the slide mechanism.

Options

Revisions

1	Update per Equalizer Specs

**33H HURRICANE (19.5) TIRES
EQUALIZER JACKS (FULLY AUTOMATIC)
STANDARD ON THIS UNIT**

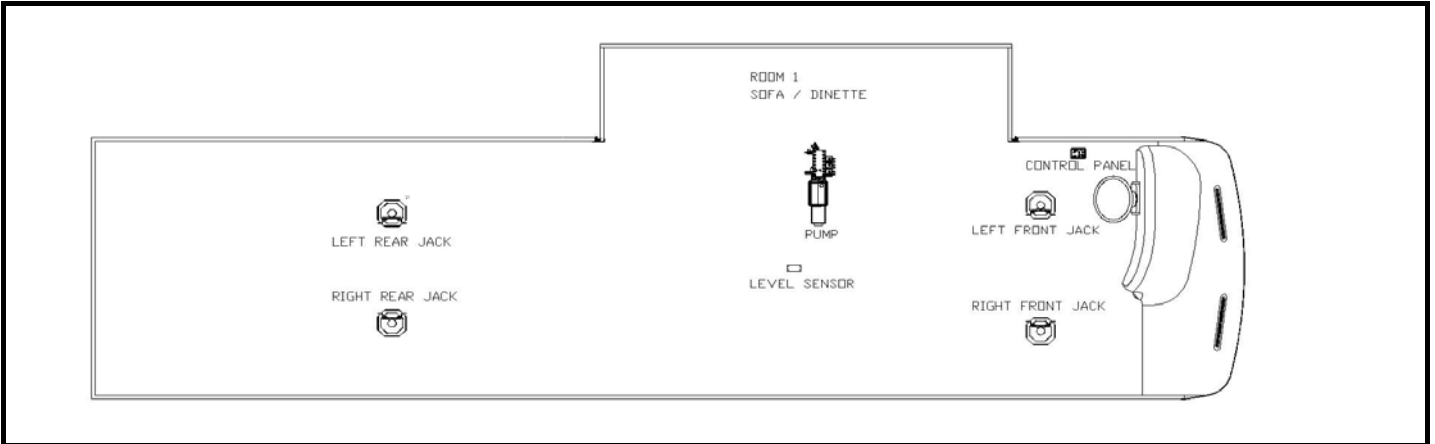

Notes:

1) Jacks mount in two different locations on bracket depending on tire size of chassis.

a) 19.5 Tires: Top hole in jack to top hole in bracket. Use 4 bolts in welded area of bracket.

b) 22.5 Tires: Top hole in jack to second hole in bracket. Use 6 bolts, 4 in welded area of bracket & 2 below welded area.

Item, Length	Description / Location	Qty	Color	Vendor PN		
Kit	(Items listed below)	1		8270		
Pump	5-Function, 1 Room, Jacks	1		7242BR		
Jack	12,000 lbs, 16" Stroke	4		7214		
Touch Pad	Located to the left of the drivers seat	1		2318		
Control Box	Attached to bottom of structure	1		2730		
Flow Divider	Mounted inside pump compartment	N/A		N/A		
Hose, 132	Pump to Jack, Left Front	2	Brown	2466	Measuring from inside of firewall, this is the end location of the hydraulic hoses where they attach to the slide mechanism.	
Hose, 216	Pump to Jack, Left Rear	2	Orange	2473		
Hose, 180	Pump to Jack, Right Front	1	White	2470		
Hose, 264	Pump to Jack, Right Rear	1	Yellow	2476		
Hose, 96	Left Front Jack, Right Front Jack	1	Whi/Brn.	2463		
Hose, 96	Left Rear Jack, Right Rear Jack	1	Yel/Ora.	2463		
Hose, N/A	Pump to Flow Divider	N/A	Green	N/A		N/A
Hose, N/A	Flow divider to front slide, Room 1	N/A	Green	N/A		N/A
Hose, N/A	Flow divider to rear slide, Room 1	N/A	Green	N/A		N/A
Hose, 36	Pump to Room 1	2	Green	2458		127 / Drivers Side
Slide Unit	Room 1-36" Above floor slide	1		7164		
Hose, N/A	Pump to Room 2	N/A	Purple	N/A	N/A	
Slide Unit						
Hose, N/A	Pump to Room 3	N/A	Gray	N/A	N/A	
Slide Unit						
Hose, N/A	Pump to Room 4	N/A	Red	N/A	N/A	
Slide Unit						
Travel Clamp	Two per Slide	N/A		HWH	N/A	

Options

Revisions

1	Update per Equalizer Specs				

**33T HURRICANE (19.5) TIRES
EQUALIZER JACKS (FULLY AUTOMATIC)
STANDARD ON THIS UNIT**

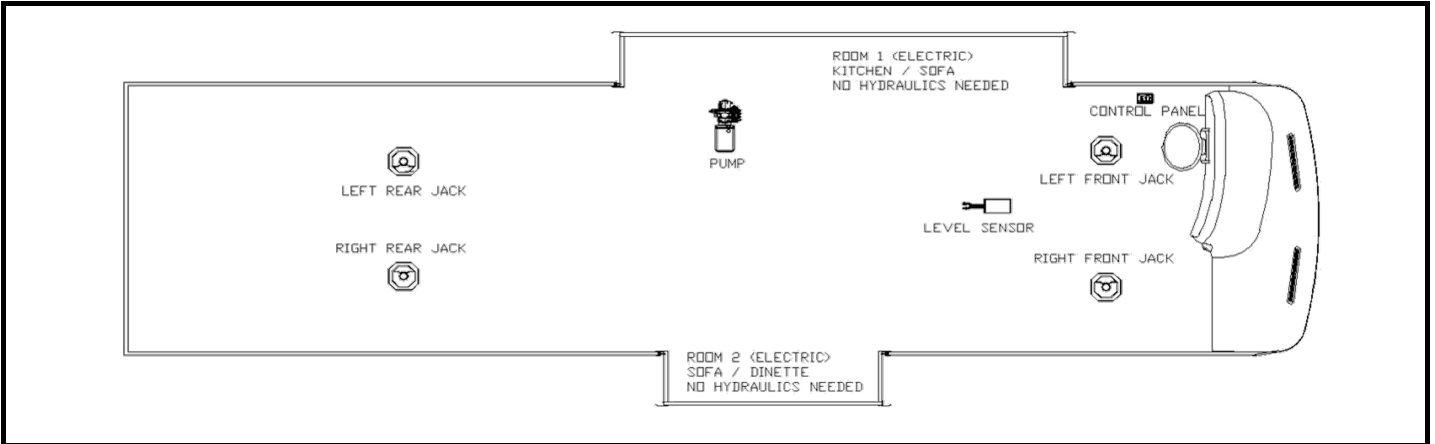

Notes:

1) Jacks mount in two different locations on bracket depending on tire size of chassis.

a) 19.5 Tires: Top hole in jack to top hole in bracket. Use 4 bolts in welded area of bracket.

b) 22.5 Tires: Top hole in jack to second hole in bracket. Use 6 bolts, 4 in welded area of bracket & 2 below welded area.

Item, Length	Description / Location	Qty	Color	Vendor PN	
Kit	(Items listed below)	1		8381	Measuring from inside of firewall, this is the end location of the hydraulic hoses where they attach to the slide mechanism.
Pump	4-Function, Jacks	1		7239BR	
Jack	12,000 lbs, 16" Stroke	4		7214	
Touch Pad	Located to the left of the drivers seat	1		2318	
Control Box	Attached to bottom of structure	1		2730	
Flow Divider	Mounted inside pump compartment	N/A		N/A	
Hose, 204	Pump to Jack, Left Front	2	Brown	2472	
Hose, 180	Pump to Jack, Left Rear	2	Orange	2470	
Hose, 252	Pump to Jack, Right Front	1	White	2587	
Hose, 216	Pump to Jack, Right Rear	1	Yellow	2473	
Hose, 96	Left Front Jack, Right Front Jack	1	Whi/Brn.	2463	
Hose, 96	Left Rear Jack, Right Rear Jack	1	Yel/Ora.	2463	
Hose, N/A	Pump to Flow Divider	N/A	N/A	N/A	N/A
Hose, N/A	Flow divider to front slide, Room 1	N/A	N/A	N/A	N/A
Hose, N/A	Flow divider to rear slide, Room 1	N/A	N/A	N/A	N/A
Hose, N/A	Pump to Room 1	N/A	Green	N/A	N/A
Hose, N/A	Pump to Room 2	N/A	Purple	N/A	N/A
Hose, N/A	Pump to Room 3	N/A	Gray	N/A	N/A
Hose, N/A	Pump to Room 4	N/A	Red	N/A	N/A
Hose, N/A	Pump to Generator Slide	N/A	TBD	N/A	N/A
Travel Clamp	Two per Slide	N/A		HWH	N/A

Options

Revisions

**34B HURRICANE (19.5) TIRES
EQUALIZER JACKS (FULLY AUTOMATIC)
STANDARD ON THIS UNIT**

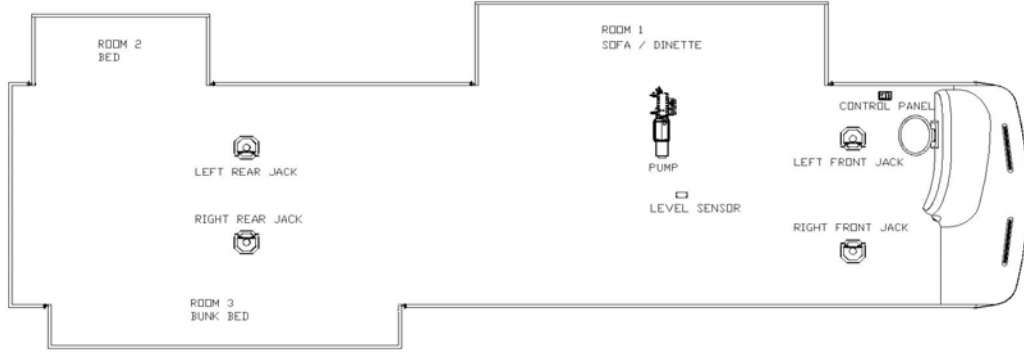

Notes:

1) Jacks mount in two different locations on bracket depending on tire size of chassis.

a) 19.5 Tires: Top hole in jack to top hole in bracket. Use 4 bolts in welded area of bracket.

b) 22.5 Tires: Top hole in jack to second hole in bracket. Use 6 bolts, 4 in welded area of bracket & 2 below welded area.

Item, Length	Description / Location	Qty	Color	Vendor PN	
Kit	(Items listed below)	1		8323	Measuring from inside of firewall, this is the end location of the hydraulic hoses where they attach to the slide mechanism.
Pump	7-Function, 3 Rooms, Jacks	1		7301BR	
Jack	12,000 lbs, 16" Stroke	4		7214	
Touch Pad	Located to the left of the drivers seat	1		2318	
Control Box	Attached to bottom of structure	1		2730	
Flow Divider	Mounted inside pump compartment	N/A		N/A	
Hose, 132	Pump to Jack, Left Front	2	Brown	2466	
Hose, 240	Pump to Jack, Left Rear	2	Orange	2475	
Hose, 168	Pump to Jack, Right Front	2	White	2469	
Hose, 264	Pump to Jack, Right Rear	1	Yellow	2476	
Hose, 96	Left Rear Jack, Right Rear Jack	1	Yel/Ora.	2463	
Hose, 36	Pump to Room 1	2	Green	2458	127 / Drivers Side
Slide Unit	Room 1-36" Above Floor Slide	1		7164	
Hose, 372	Pump to Room 2	2	Purple	2481	347 / Drivers Side
Slide Unit	Room 2-30" Bed Slide(Lipper)	1		134998	
Hose w90, 372	Pump to Room 3	2	Gray	2481	307 / Passenger Side
Slide Unit	Room 3-18" Above floor slide	1		7135	
Hose, N/A	Pump to Room 4	N/A	Red	N/A	N/A
Travel Clamp	Two per Slide	N/A		N/A	N/A

Options

Revisions

9/1/2006	Add 34S to 34B chart
2	Update per Equalizer Specs

**34N HURRICANE (19.5) TIRES
EQUALIZER JACKS (FULLY AUTOMATIC)
STANDARD ON THIS UNIT**

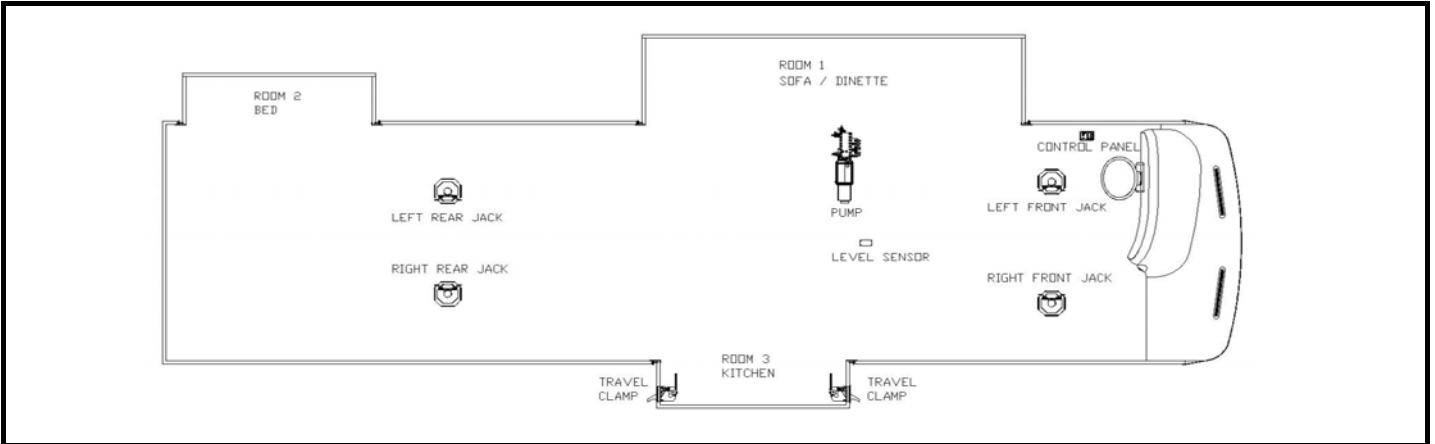

Notes:

1) Jacks mount in two different locations on bracket depending on tire size of chassis.

a) 19.5 Tires: Top hole in jack to top hole in bracket. Use 4 bolts in welded area of bracket.

b) 22.5 Tires: Top hole in jack to second hole in bracket. Use 6 bolts, 4 in welded area of bracket & 2 below welded area.

Item, Length	Description / Location	Qty	Color	Vendor PN		
Kit	(Items listed below)	1		8269		
Pump	7-Function, 3 Rooms, Jacks	1		7301BR		
Jack	12,000 lbs, 16" Stroke	4		7214		
Touch Pad	Located to the left of the drivers seat	1		2318		
Control Box	Attached to bottom of structure	1		2730		
Flow Divider	Mounted inside pump compartment	N/A		N/A		
Hose, 132	Pump to Jack, Left Front	2	Brown	2466	Measuring from inside of firewall, this is the end location of the hydraulic hoses where they attach to the slide mechanism.	
Hose, 216	Pump to Jack, Left Rear	2	Orange	2473		
Hose, 180	Pump to Jack, Right Front	2	White	2470		
Hose, 264	Pump to Jack, Right Rear	1	Yellow	2476		
Hose, 96	Left Rear Jack, Right Rear Jack	1	Yel/Ora.	2463		
Hose, N/A	Pump to Flow Divider	N/A	Green	N/A		N/A
Hose, N/A	Flow divider to rear slide, Room 1	N/A	Green	N/A		N/A
Hose, N/A	Flow divider to front slide, Room 1	N/A	Green	N/A		N/A
Hose, 36	Pump to Room 1	2	Green	2458		127 / Drivers Side
Slide Unit	Room 1-36" Above Floor Slide	1		7164		
Hose, 372	Pump to Room 2	2	Purple	2481	305 / Passenger Side	
Slide Unit	Room 2-30" Bed slide (Lippert)	1		134998		
Hose w90, 108	Pump to Room 3	2	Gray	2464	160 / Passenger Side	
Slide Unit	Room 3-18" Above floor slide	1		7135		
Hose, N/A	Pump to Room 4	N/A	Red	N/A	N/A	
Slide Unit						
Travel Clamp	Two per Slide	2		HWH	N/A	

Options

Revisions

1	Update per Equalizer Specs				

**34U HURRICANE (22.5) TIRES
EQUALIZER JACKS (FULLY AUTOMATIC)
STANDARD ON THIS UNIT**

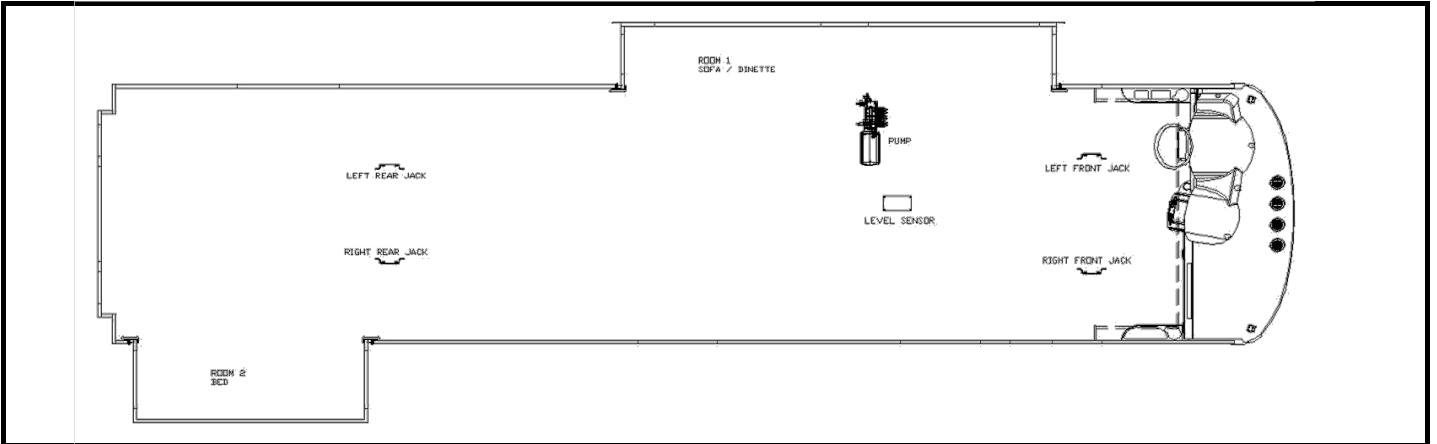

Notes:

- 1) Jacks mount in two different locations on bracket depending on tire size of chassis.
 - a) 19.5 Tires: Top hole in jack to top hole in bracket. Use 4 bolts in welded area of bracket.
 - b) 22.5 Tires: Top hole in jack to second hole in bracket. Use 6 bolts, 4 in welded area of bracket & 2 below welded area.

Item, Length	Description / Location	Qty	Color	Vendor PN	
Kit	(Items listed below)	1		8466	Measuring from inside of firewall, this is the end location of the hydraulic hoses where they attach to the slide mechanism.
Pump	6-Function, 2 Rooms & Jacks	1		7243BR	
Jack	12,000 lbs, 16" Stroke	4		7214	
Touch Pad	Located to the left of the drivers seat	1		2318	
Control Box	Attached to bottom of structure	1		2730	
Sync Cylinder	Mounted behind pump compartment	N/A		N/A	
Hose, 132	Pump to Jack, Left Front	2	Brown	2466	
Hose, 240	Pump to Jack, Left Rear	2	Orange	2475	
Hose, 168	Pump to Jack, Right Front	2	White	2469	
Hose, 264	Pump to Jack, Right Rear	1	Yellow	2476	
Hose, 96	Left Rear Jack, Right Rear Jack	1	Yel/Ora.	2463	Inside pump compartment
Hose, 36	Pump to Room 1	2	Green	2458	127 / Drivers Side
Slide Unit	Room 1-36" Above Floor Slide	1		7164	N/A
Hose, 372	Pump to Room 2	2	Purple	2481	347 / Passenger Side
Slide Unit	Room 2-30" Bed Slide(Lipper)	1		134998	
Hose, N/A	Pump to Room 3		Gray		
Slide Unit	Room 3-				N/A
Hose, N/A	Pump to Room 4	N/A	Red	N/A	N/A
Travel Clamp	Two per Slide	N/A		N/A	N/A

Options					

Revisions					

**34Y HURRICANE (19.5) TIRES
EQUALIZER JACKS (FULLY AUTOMATIC)
STANDARD ON THIS UNIT**

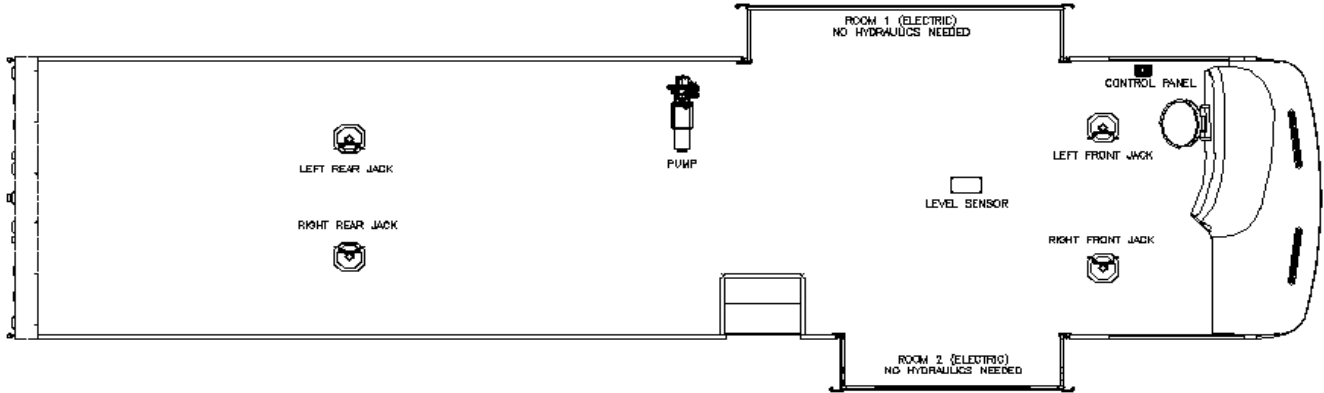

Notes:

1) Jacks mount 2nd hole from top to top mounting plate hole.

Item, Length	Description / Location	Qty	Color	Vendor PN		
Kit	(Items listed below)	1		8365	Measuring from back of cab floor, this is the end location of the hydraulic hoses where they attach to the slide mechanism.	
Pump	4-Function, Jacks Only	1		7239BR		
Jack	12,000 lbs, 16" Stroke	4		7214		
Touch Pad	Located to the left of the drivers seat	1		2318		
Control Box	Attached to bottom of structure	1		2730		
Flow Divider	Mounted inside pump compartment	N/A		N/A		
Hose, 180	Pump to Jack, Left Front	2	Brown	2470		
Hose, 180	Pump to Jack, Left Rear	2	Orange	2470		
Hose, 216	Pump to Jack, Right Front	1	White	2473		
Hose, 180	Pump to Jack, Right Rear	1	Yellow	2470		
Hose, 96	Left Front Jack, Right Front Jack	1	Whi/Brn.	2463		
Hose, 96	Left Rear Jack, Right Rear Jack	1	Yel/Ora.	2463		
Hose, N/A	Pump to Flow Divider	N/A	N/A	N/A		N/A
Hose, N/A	Flow divider to front slide, Room 1	N/A	N/A	N/A		N/A
Hose, N/A	Flow divider to rear slide, Room 1	N/A	N/A	N/A		N/A
Hose, N/A	Pump to Room 1	N/A	Green	N/A		N/A
Hose, N/A	Pump to Room 2	N/A	Purple	N/A		N/A
Hose, N/A	Pump to Room 3	N/A	Gray	N/A		N/A
Hose, N/A	Pump to Room 4	N/A	Red	N/A		N/A
Hose, N/A	Pump to Generator Slide	N/A	TBD	N/A		N/A
Travel Clamp	Two per Slide	N/A		HWH	N/A	
Options						

Revisions

1	Update per Equalizer Specs			

34Y FUNMOVER
EQUALIZER JACKS (FULLY AUTOMATIC)
STANDARD ON THIS UNIT

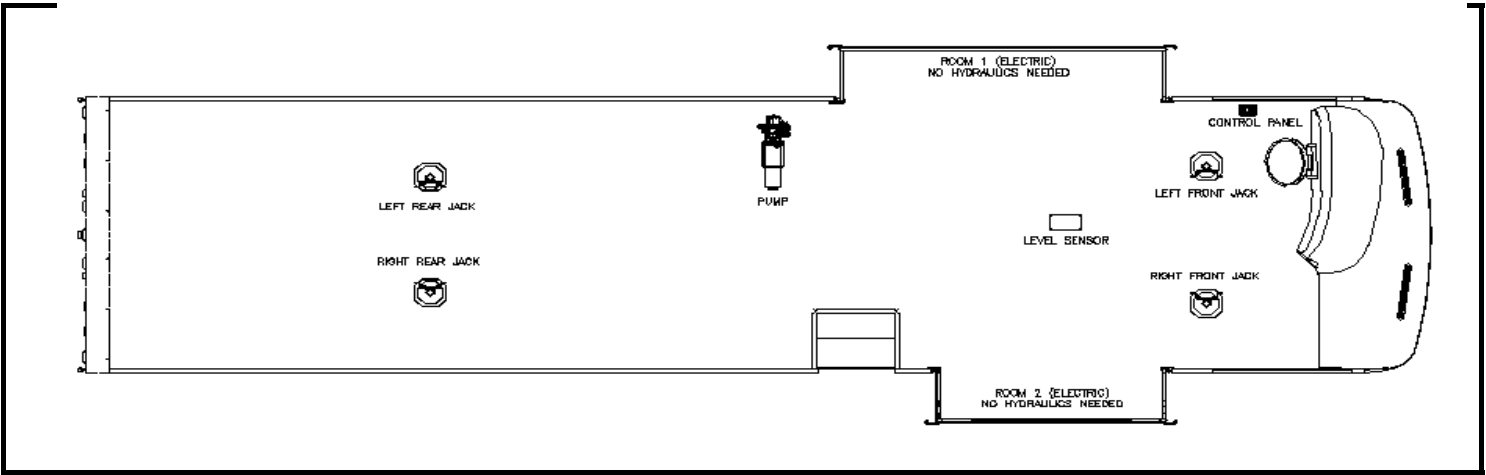

Notes:

1) Jacks mount 2nd hole from top to top mounting plate hole.

Item, Length	Description / Location	Qty	Color	Vendor PN		
Kit	(Items listed below)	1		8365	Measuring from back of cab floor, this is the end location of the hydraulic hoses where they attach to the slide mechanism.	
Pump	4-Function, Jacks Only	1		7239BR		
Jack	12,000 lbs, 16" Stroke	4		7214		
Touch Pad	Located to the left of the drivers seat	1		2318		
Control Box	Attached to bottom of structure	1		2730		
Flow Divider	Mounted inside pump compartment	N/A		N/A		
Hose, 180	Pump to Jack, Left Front	2	Brown	2470		
Hose, 180	Pump to Jack, Left Rear	2	Orange	2470		
Hose, 216	Pump to Jack, Right Front	1	White	2473		
Hose, 180	Pump to Jack, Right Rear	1	Yellow	2470		
Hose, 96	Left Front Jack, Right Front Jack	1	Whi/Brn.	2463		
Hose, 96	Left Rear Jack, Right Rear Jack	1	Yel/Ora.	2463		
Hose, N/A	Pump to Flow Divider	N/A	N/A	N/A		N/A
Hose, N/A	Flow divider to front slide, Room 1	N/A	N/A	N/A		N/A
Hose, N/A	Flow divider to rear slide, Room 1	N/A	N/A	N/A		N/A
Hose, N/A	Pump to Room 1	N/A	Green	N/A	N/A	
Hose, N/A	Pump to Room 2	N/A	Purple	N/A	N/A	
Hose, N/A	Pump to Room 3	N/A	Gray	N/A	N/A	
Hose, N/A	Pump to Room 4	N/A	Red	N/A	N/A	
Hose, N/A	Pump to Generator Slide	N/A	TBD	N/A	N/A	
Travel Clamp	Two per Slide	N/A		HWH	N/A	
Options						
Revisions	Description	By	Date			

**35 D FUNMOVER
EQUALIZER JACKS (FULLY AUTOMATIC)
OPTIONAL ON THIS UNIT**

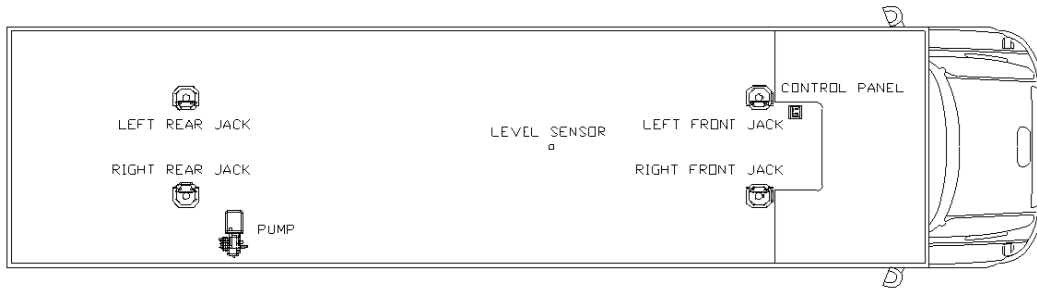

Notes:

1) Jacks mount 2nd hole from top to top mounting plate hole.

Item, Length	Description / Location	Qty	Color	Vendor PN		
Kit	(Items listed below)	1		8251	Measuring from back of cab floor, this is the end location of the hydraulic hoses where they attach to the slide mechanism.	
Pump	4-Function, Jacks Only	1		7239BR		
Jack	12,000 lbs, 16" Stroke	4		7214		
Touch Pad	Located to the right of the drivers seat	1		2318		
Control Box	Attached to bottom of structure	1		2730		
Flow Divider	Mounted inside pump compartment	N/A		N/A		
Hose, 288	Pump to Jack, Left Front	1	Brown	2478		
Hose, 108	Pump to Jack, Left Rear	2	Orange	2464		
Hose, 276	Pump to Jack, Right Front	2	White	2477		
Hose, 60	Pump to Jack, Right Rear	2	Yellow	2460		
Hose, 96	Left Front Jack, Right Front Jack	1	Whi/Brn.	2463		
Hose, N/A	Pump to Flow Divider	N/A	N/A	N/A		N/A
Hose, N/A	Flow divider to front slide, Room 1	N/A	N/A	N/A		N/A
Hose, N/A	Flow divider to rear slide, Room 1	N/A	N/A	N/A		N/A
Hose, N/A	Pump to Room 1	N/A	Green	N/A		N/A
Hose, N/A	Pump to Room 2	N/A	Purple	N/A		N/A
Hose, N/A	Pump to Room 3	N/A	Gray	N/A		N/A
Hose, N/A	Pump to Room 4	N/A	Red	N/A		N/A
Hose, N/A	Pump to Generator Slide	N/A	TBD	N/A		N/A
Travel Clamp	Two per Slide	N/A		HWH	N/A	
Options						
Revisions	Description		By	Date		

42D FUN MOVER
EQUALIZER JACKS (FULLY AUTOMATIC)
OPTIONAL ON THIS UNIT

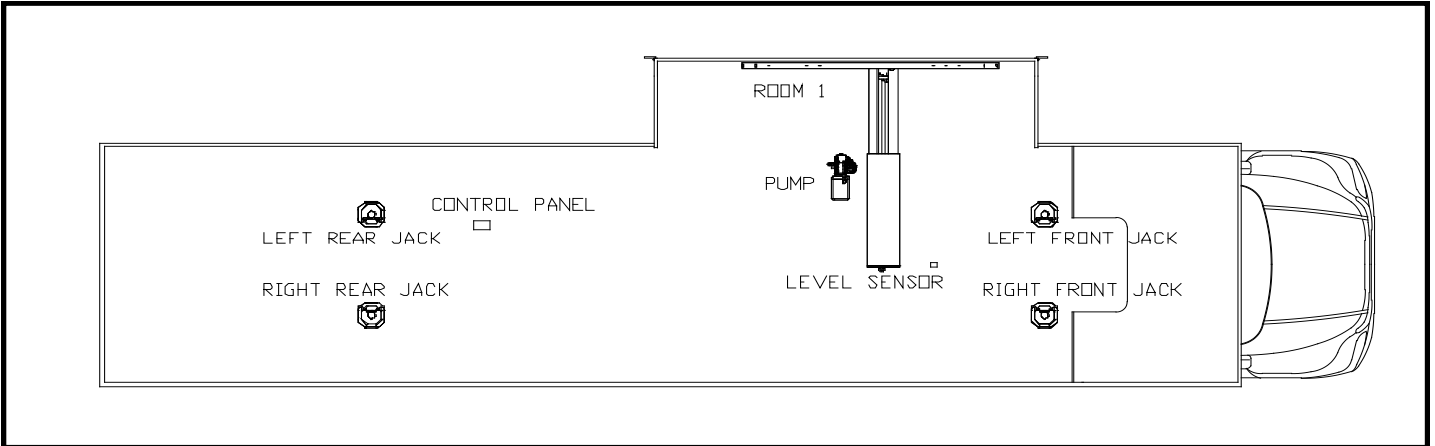

Notes:

1) Jacks mount 2nd hole from top to top mounting plate hole.

Item, Length	Description / Location	Qty	Color	Vendor PN	Measuring from back of cab floor, this is the end location of the hydraulic hoses where they attach to the slide mechanism.
Kit	(Items listed below)	1		8250	
Pump	5-Function, 1 Room, Jacks	1		7242BR	
Flow Divider	Mounted inside pump compartment	N/A		N/A	
Hose, N/A	Pump to Flow Divider	N/A	N/A	N/A	N/A
Hose, N/A	Flow divider to front slide, Room 1	N/A	N/A	N/A	N/A
Hose, N/A	Flow divider to rear slide, Room 1	N/A	N/A	N/A	N/A
Hose, 84	Pump to Room 1	2	Green	2462	73 / Drivers Side
Slide Unit	Room 1-36" Above floor Slide	1		7164	
Hose, N/A	Pump to Room 2	N/A	Purple	N/A	N/A
Hose, N/A	Pump to Room 3	N/A	Gray	N/A	N/A
Hose, N/A	Pump to Room 4	N/A	Red	N/A	N/A
Hose, N/A	Pump to Generator Slide	N/A	TBD	N/A	N/A
Travel Clamp	Two per Slide	N/A		HWH	N/A
Options					
Kit	(Items listed below)	1		8253	
Jack	12,000 lbs, 16" Stroke	4		7214	
Touch Pad	Located to the right of the drivers seat	1		2318	
Control Box	Attached to bottom of structure	1		2730	
Hose, 132	Pump to Jack, Left Front	2	Brown	2466	
Hose, 264	Pump to Jack, Left Rear	2	Orange	2476	
Hose, 168	Pump to Jack, Right Front	2	White	2469	
Hose, 276	Pump to Jack, Right Rear	1	Yellow	2477	
Hose, 96	Left Rear Jack, Right Rear Jack	1	Yel/Ora.	2463	
Revisions					

42C FUN MOVER
EQUALIZER JACKS (FULLY AUTOMATIC)
OPTIONAL ON THIS UNIT

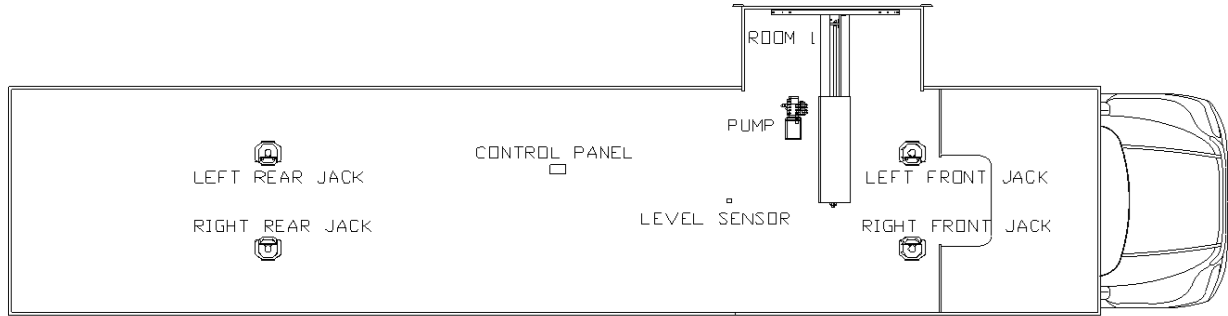

Notes:

1) Jacks mount top hole to 2nd from top mounting plate hole.

Item, Length	Description / Location	Qty	Color	Vendor PN	Measuring from back of cab floor, this is the end location of the hydraulic hoses where they attach to the slide mechanism.
Kit	(Items listed below)	1		8250	
Pump	5-Function, 1 Room, Jacks	1		7242BR	
Flow Divider	Mounted inside pump compartment	N/A		N/A	
Hose, N/A	Pump to Flow Divider	N/A	N/A	N/A	N/A
Hose, N/A	Flow divider to front slide, Room 1	N/A	N/A	N/A	N/A
Hose, N/A	Flow divider to rear slide, Room 1	N/A	N/A	N/A	N/A
Hose, 84	Pump to Room 1	2	Green	2462	42 / Drivers Side
Slide Unit	Room 1-36" Above floor Slide	1		7164	
Hose, N/A	Pump to Room 2	N/A	Purple	N/A	N/A
Hose, N/A	Pump to Room 3	N/A	Gray	N/A	N/A
Hose, N/A	Pump to Room 4	N/A	Red	N/A	N/A
Hose, N/A	Pump to Generator Slide	N/A	TBD	N/A	N/A
Travel Clamp	Two per Slide	N/A		HWH	N/A
Options					
Kit	(Items listed below)	1		8253	
Jack	12,000 lbs, 16" Stroke	4		7214	
Touch Pad	Located to the right of the drivers seat	1		2318	
Control Box	Attached to bottom of structure	1		2730	
Hose, 132	Pump to Jack, Left Front	2	Brown	2466	
Hose, 264	Pump to Jack, Left Rear	2	Orange	2476	
Hose, 168	Pump to Jack, Right Front	2	White	2469	
Hose, 276	Pump to Jack, Right Rear	1	Yellow	2477	
Hose, 96	Left Rear Jack, Right Rear Jack	1	Yel/Ora.	2463	
Revisions					

**32B KODIAK (19.5) TIRES
EQUALIZER JACKS (FULLY AUTOMATIC)
STANDARD ON THIS UNIT**

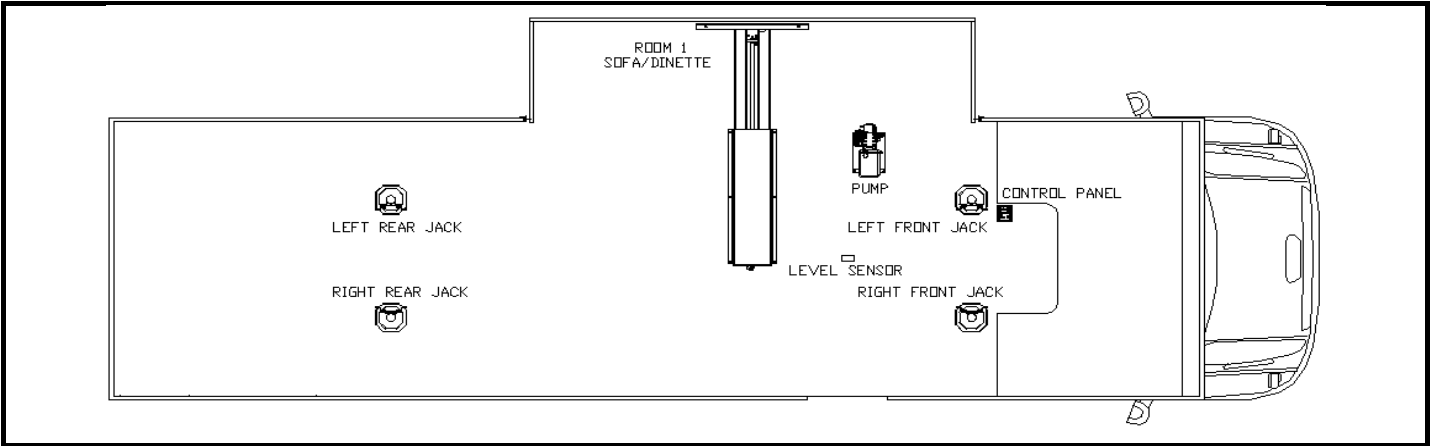

Notes:

1) Jacks mount 2nd hole from top to top mounting plate hole.

Item, Length	Description / Location	Qty	Color	Vendor PN	
Kit	(Items listed below)	1		8264	Measuring from back of cab floor, this is the end location of the hydraulic hoses where they attach to the slide mechanism.
Pump	5-Function, 1 Room, Jacks	1		7242BR	
Jack	12,000 lbs, 16" Stroke	4		7214	
Touch Pad	Located to the right of the drivers seat	1		2318	
Control Box	Attached to bottom of structure	1		2730	
Hose, 72	Pump to Jack, Left Front	2	Brown	2461	
Hose, 240	Pump to Jack, Left Rear	2	Orange	2475	
Hose, 108	Pump to Jack, Right Front	2	White	2464	
Hose, 240	Pump to Jack, Right Rear	1	Yellow	2475	
Hose, 96	Left Rear Jack, Right Rear Jack	1	Yellow	2463	
Hose, 84	Pump to Room 1	2	Green	2462	80 / Drivers Side
Slide Unit	Room 1-36" above floor slide	1		7164D	
Hose, N/A	Pump to Room 2	N/A	Purple	N/A	N/A
Slide Unit					
Hose, N/A	Pump to Room 3	N/A	Gray	N/A	N/A
Slide Unit					
Hose, N/A	Pump to Room 4	N/A	Red	N/A	N/A
Slide Unit					
Travel Clamp	Two per Slide	N/A		HWH	N/A
Options					
Revisions	Description		By	Date	
1	Made Jack, Control Panel, Level Sensor & hoses standard		JB	11/17/2005	

**33K KODIAK (19.5) TIRES
EQUALIZER JACKS (FULLY AUTOMATIC)
OPTIONAL ON THIS UNIT**

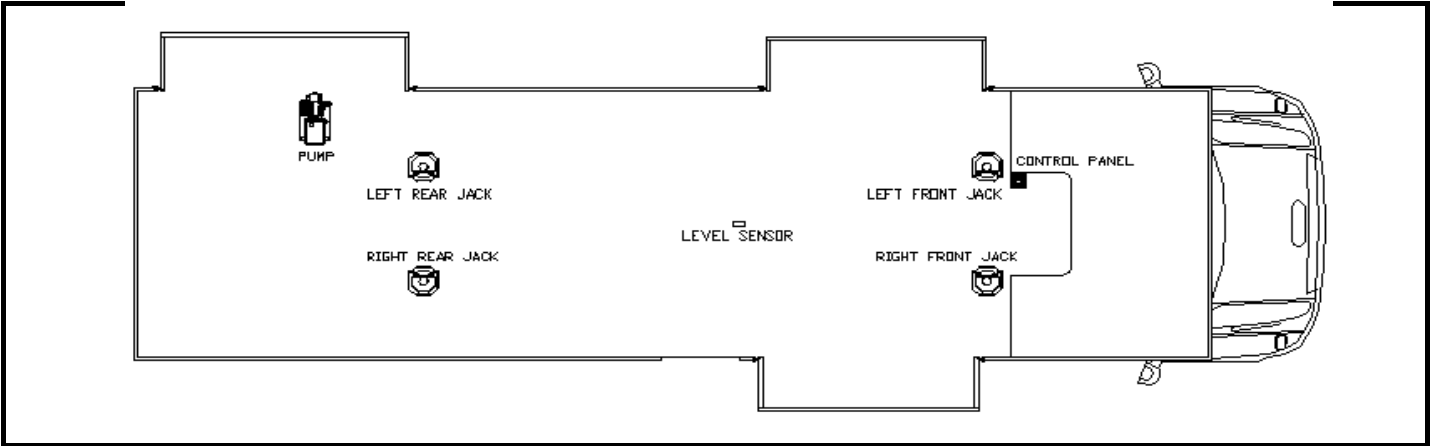

Notes:

1) Jacks mount 2nd hole from top to top mounting plate hole.

Item, Length	Description / Location	Qty	Color	Vendor PN	Measuring from back of cab floor, this is the end location of the hydraulic hoses where they attach to the slide mechanism.
Flow Divider	Mounted inside pump compartment	N/A		N/A	
Hose, N/A	Pump to Flow Divider	N/A	TBD	N/A	N/A
Hose, N/A	Flow divider to front slide, Room 1	N/A	TBD	N/A	N/A
Hose, N/A	Flow divider to rear slide, Room 1	N/A	TBD	N/A	N/A
Hose, N/A	Pump to Room 1	N/A	Green	N/A	N/A
Hose, N/A	Pump to Room 2	N/A	Purple	N/A	N/A
Hose, N/A	Pump to Room 3	N/A	Gray	N/A	N/A
Hose, N/A	Pump to Room 4	N/A	Red	N/A	N/A
Hose, N/A	Pump to Generator Slide	N/A	TBD	N/A	N/A
Travel Clamp	Two per Slide	N/A	N/A	HWH	N/A
Options					
Kit	(Items listed below)	1		8274	
Pump	4-Function, Jacks	1		7239BR	
Jack	12,000 lbs, 16" Stroke	4		7214	
Touch Pad	Located to the right of the drivers seat	1		2318	
Control Box	Attached to bottom of structure	1		2730	
Hose, 288	Pump to Jack, Left Front	2	Brown	2478	
Hose, 84	Pump to Jack, Left Rear	2	Orange	2462	
Hose, 300	Pump to Jack, Right Front	1	White	2479	
Hose, 120	Pump to Jack, Right Rear	2	Yellow	2465	
Hose, 96	Left Front Jack, Right Front Jack	1	Whi/Brn.	2463	
Revisions					

**34G KODIAK (19.5) TIRES
EQUALIZER JACKS (FULLY AUTOMATIC)
OPTIONAL ON THIS UNIT**

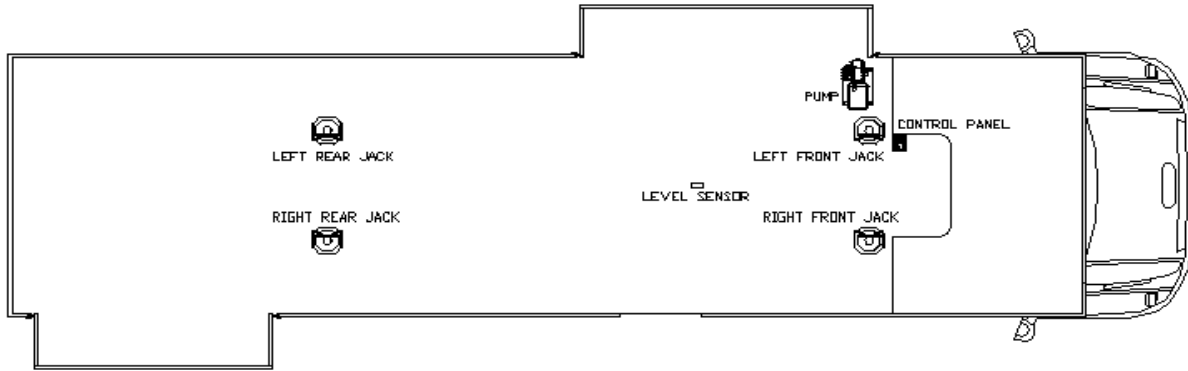

Notes:

1) Jacks mount 2nd hole from top to top mounting plate hole.

Item, Length	Description / Location	Qty	Color	Vendor PN	Measuring from back of cab floor, this is the end location of the hydraulic hoses where they attach to the slide mechanism.
Flow Divider	Mounted inside pump compartment	N/A		N/A	
Hose, N/A	Pump to Flow Divider	N/A	TBD	N/A	N/A
Hose, N/A	Flow divider to front slide, Room 1	N/A	TBD	N/A	N/A
Hose, N/A	Flow divider to rear slide, Room 1	N/A	TBD	N/A	N/A
Hose, N/A	Pump to Room 1	N/A	Green	N/A	N/A
Hose, N/A	Pump to Room 2	N/A	Purple	N/A	N/A
Hose, N/A	Pump to Room 3	N/A	Gray	N/A	N/A
Hose, N/A	Pump to Room 4	N/A	Red	N/A	N/A
Hose, N/A	Pump to Generator Slide	N/A	TBD	N/A	N/A
Travel Clamp	Two per Slide	N/A		HWH	N/A
Options					
Kit	(Items listed below)	1		8275	
Pump	4-Function, Jacks	1		7239BR	
Jack	12,000 lbs, 16" Stroke	4		7214	
Touch Pad	Located to the right of the drivers seat	1		2318	
Control Box	Attached to bottom of structure	1		2730	
Hose, 60	Pump to Jack, Left Front	2	Brown	2460	
Hose, 228	Pump to Jack, Left Rear	2	Orange	2474	
Hose, 108	Pump to Jack, Right Front	2	White	2464	
Hose, 264	Pump to Jack, Right Rear	1	Yellow	2476	
Hose, 96	Left Rear Jack, Right Rear Jack	1	Yellow	2463	
Revisions					

**34H KODIAK (19.5) TIRES
EQUALIZER JACKS (FULLY AUTOMATIC)
STANDARD ON THIS UNIT**

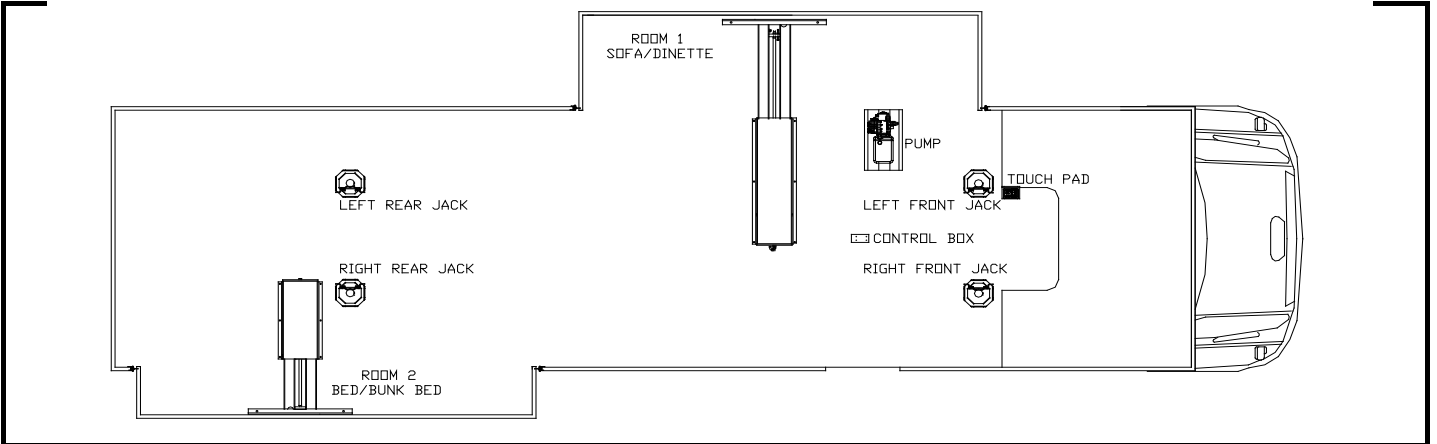

Notes:

1) Jacks mount 2nd hole from top to top mounting plate hole.

Item, Length	Description / Location	Qty	Color	Vendor PN		
Kit	(Items listed below)	1		8341	Measuring from back of cab floor, this is the end location of the hydraulic hoses where they attach to the slide mechanism.	
Pump	6-Function, 2 Room, Jacks	1		7243BR		
Jack	12,000 lbs, 16" Stroke	4		7214		
Touch Pad	Located to the right of the drivers seat	1		2318		
Control Box	Attached to bottom of structure	1		2730		
Hose, 84	Pump to Jack, Left Front	2	Brown	2462		
Hose, 252	Pump to Jack, Left Rear	2	Orange	2587		
Hose, 108	Pump to Jack, Right Front	2	White	2464		
Hose, 252	Pump to Jack, Right Rear	1	Yellow	2587		
Hose, 96	Left Rear Jack, Right Rear Jack	1	Yel/Ora.	2463		
Hose, 84	Pump to Room 1	2	Green	2462		80 / Drivers Side
Slide Unit	Room 1-36" above floor slide	1		7164B		
Hose, 300	Pump to Room 2	2	Purple	2479		245 / Passenger Side
Slide Unit	Room 2-18" above floor slide	1		7135B		
Hose, N/A	Pump to Room 3	N/A	Gray	N/A	N/A	
Slide Unit						
Hose, N/A	Pump to Room 4	N/A	Red	N/A	N/A	
Slide Unit						
Travel Clamp	Two per Slide	N/A		HWH	N/A	
Options						
Revisions	Description		By	Date		

**35B KODIAK (19.5) TIRES
EQUALIZER JACKS (FULLY AUTOMATIC)
STANDARD ON THIS UNIT**

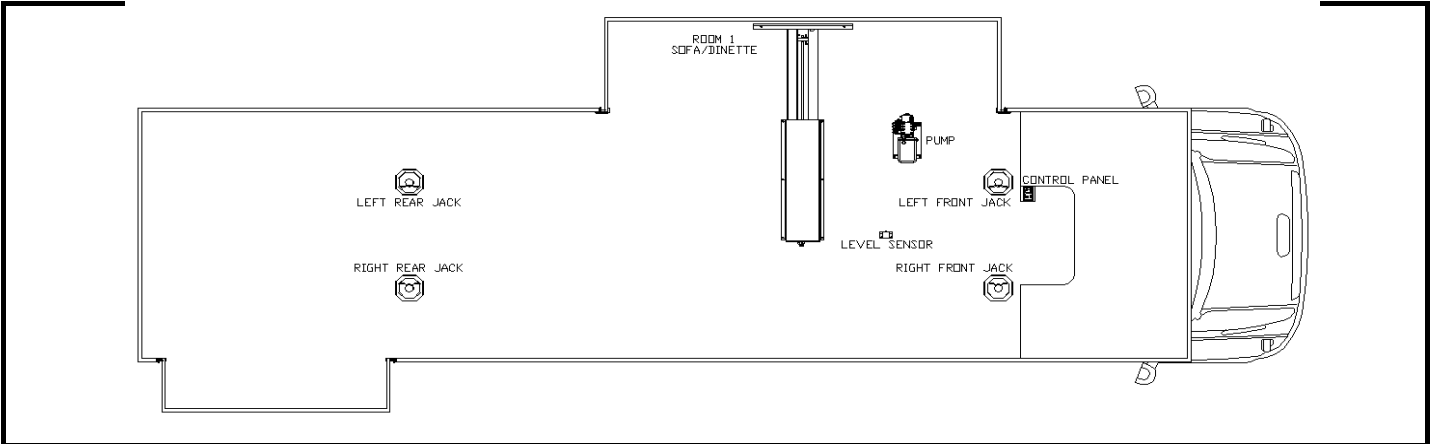

Notes:

1) Jacks mount 2nd hole from top to top mounting plate hole.

Item, Length	Description / Location	Qty	Color	Vendor PN	
Kit	(Items listed below)	1		8264	Measuring from back of cab floor, this is the end location of the hydraulic hoses where they attach to the slide mechanism.
Pump	5-Function, 1 Room, Jacks	1		7242BR	
Jack	12,000 lbs, 16" Stroke	4		7214	
Touch Pad	Located to the right of the drivers seat	1		2318	
Control Box	Attached to bottom of structure	1		2730	
Hose, 72	Pump to Jack, Left Front	2	Brown	2461	
Hose, 240	Pump to Jack, Left Rear	2	Orange	2475	
Hose, 108	Pump to Jack, Right Front	2	White	2464	
Hose, 240	Pump to Jack, Right Rear	1	Yellow	2475	
Hose, 96	Left Rear Jack, Right Rear Jack	1	Yel/Ora.	2463	
Hose, 84	Pump to Room 1	2	Green	2462	80 / Drivers Side
Slide Unit	Room 1-36" above floor slide	1		7164D	
Hose, N/A	Pump to Room 2		Purple		
Slide Unit					
Hose, N/A	Pump to Room 3		Gray		
Slide Unit					
Hose, N/A	Pump to Room 4		Red		
Slide Unit					
Travel Clamp	Two per Slide			HWH	
Options					
Revisions	Description		By	Date	

**32B KODIAK (19.5) TIRES
EQUALIZER JACKS (FULLY AUTOMATIC)
STANDARD ON THIS UNIT**

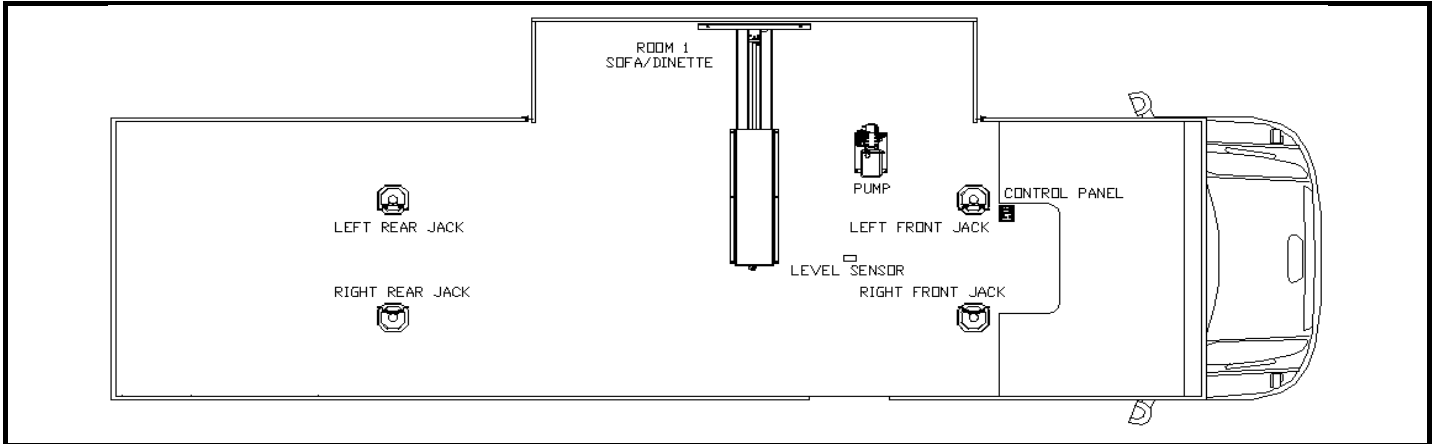

Notes:

1) Jacks mount 2nd hole from top to top mounting plate hole.

Item, Length	Description / Location	Qty	Color	Vendor PN	
Kit	(Items listed below)	1		8264	Measuring from back of cab floor, this is the end location of the hydraulic hoses where they attach to the slide mechanism.
Pump	5-Function, 1 Room, Jacks	1		7242BR	
Jack	12,000 lbs, 16" Stroke	4		7214	
Touch Pad	Located to the right of the drivers seat	1		2318	
Control Box	Attached to bottom of structure	1		2730	
Hose, 72	Pump to Jack, Left Front	2	Brown	2461	
Hose, 240	Pump to Jack, Left Rear	2	Orange	2475	
Hose, 108	Pump to Jack, Right Front	2	White	2464	
Hose, 240	Pump to Jack, Right Rear	1	Yellow	2475	
Hose, 96	Left Rear Jack, Right Rear Jack	1	Yel/Ora.	2463	
Hose, 84	Pump to Room 1	2	Green	2462	80 / Drivers Side
Slide Unit	Room 1-36" above floor slide	1		7164B	
Hose, N/A	Pump to Room 2	N/A	Purple	N/A	N/A
Slide Unit					
Hose, N/A	Pump to Room 3	N/A	Gray	N/A	N/A
Slide Unit					
Hose, N/A	Pump to Room 4	N/A	Red	N/A	N/A
Slide Unit					
Travel Clamp	Two per Slide	N/A		HWH	N/A
Options					
Revisions	Description		By	Date	
1	Made Jack, Control Panel, Level Sensor & hoses standard		JB	11/17/2005	

**33K KODIAK (19.5) TIRES
EQUALIZER JACKS (FULLY AUTOMATIC)
OPTIONAL ON THIS UNIT**

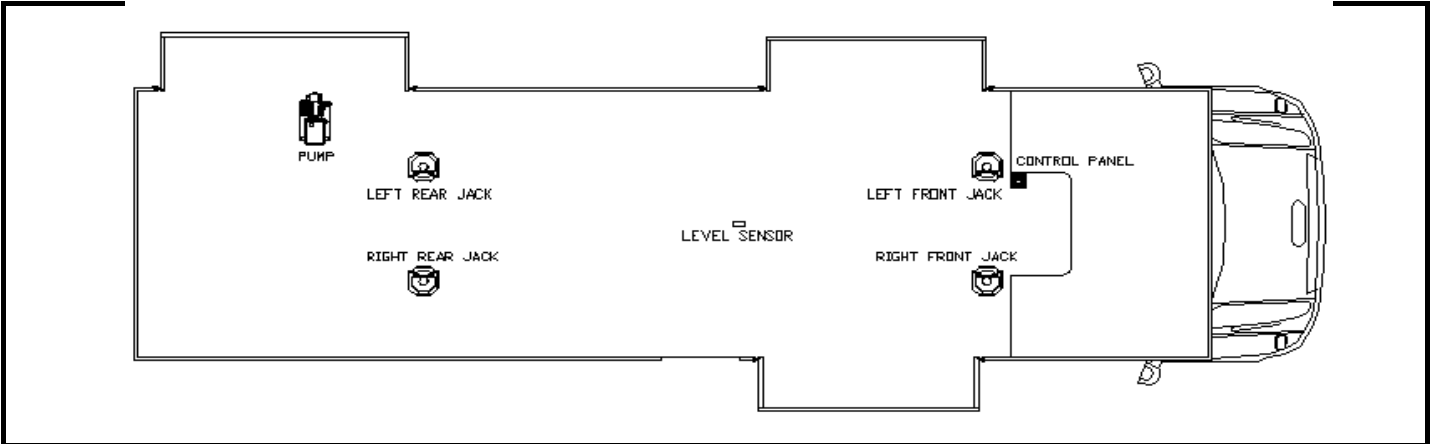

Notes:

1) Jacks mount 2nd hole from top to top mounting plate hole.

Item, Length	Description / Location	Qty	Color	Vendor PN	Measuring from back of cab floor, this is the end location of the hydraulic hoses where they attach to the slide mechanism.
Flow Divider	Mounted inside pump compartment	N/A		N/A	
Hose, N/A	Pump to Flow Divider	N/A	TBD	N/A	N/A
Hose, N/A	Flow divider to front slide, Room 1	N/A	TBD	N/A	N/A
Hose, N/A	Flow divider to rear slide, Room 1	N/A	TBD	N/A	N/A
Hose, N/A	Pump to Room 1	N/A	Green	N/A	N/A
Hose, N/A	Pump to Room 2	N/A	Purple	N/A	N/A
Hose, N/A	Pump to Room 3	N/A	Gray	N/A	N/A
Hose, N/A	Pump to Room 4	N/A	Red	N/A	N/A
Hose, N/A	Pump to Generator Slide	N/A	TBD	N/A	N/A
Travel Clamp	Two per Slide	N/A	N/A	HWH	N/A
Options					
Kit	(Items listed below)	1		8274	
Pump	4-Function, Jacks	1		7239BR	
Jack	12,000 lbs, 16" Stroke	4		7214	
Touch Pad	Located to the right of the drivers seat	1		2318	
Control Box	Attached to bottom of structure	1		2730	
Hose, 288	Pump to Jack, Left Front	2	Brown	2478	
Hose, 84	Pump to Jack, Left Rear	2	Orange	2462	
Hose, 300	Pump to Jack, Right Front	1	White	2479	
Hose, 120	Pump to Jack, Right Rear	2	Yellow	2465	
Hose, 96	Left Front Jack, Right Front Jack	1	Whi/Brn.	2463	
Revisions					

**34G KODIAK (19.5) TIRES
EQUALIZER JACKS (FULLY AUTOMATIC)
OPTIONAL ON THIS UNIT**

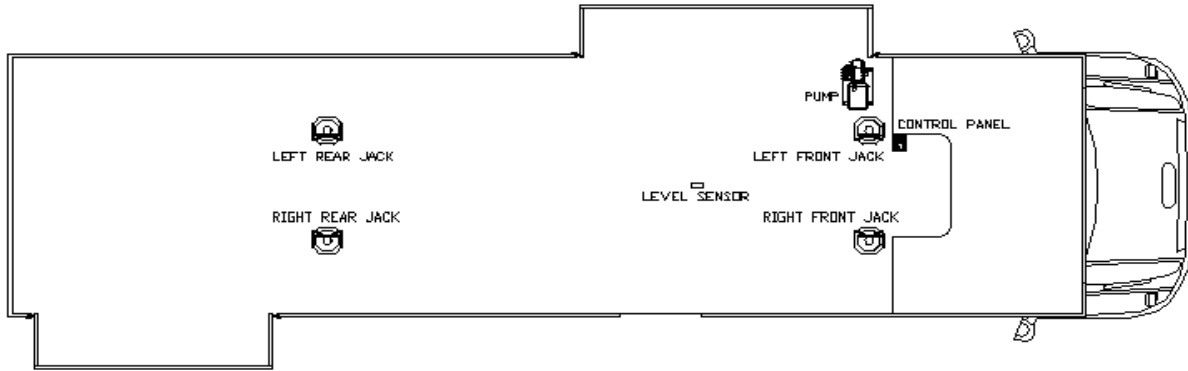

Notes:

1) Jacks mount 2nd hole from top to top mounting plate hole.

Item, Length	Description / Location	Qty	Color	Vendor PN	Measuring from back of cab floor, this is the end location of the hydraulic hoses where they attach to the slide mechanism.
Flow Divider	Mounted inside pump compartment	N/A		N/A	
Hose, N/A	Pump to Flow Divider	N/A	TBD	N/A	N/A
Hose, N/A	Flow divider to front slide, Room 1	N/A	TBD	N/A	N/A
Hose, N/A	Flow divider to rear slide, Room 1	N/A	TBD	N/A	N/A
Hose, N/A	Pump to Room 1	N/A	Green	N/A	N/A
Hose, N/A	Pump to Room 2	N/A	Purple	N/A	N/A
Hose, N/A	Pump to Room 3	N/A	Gray	N/A	N/A
Hose, N/A	Pump to Room 4	N/A	Red	N/A	N/A
Hose, N/A	Pump to Generator Slide	N/A	TBD	N/A	N/A
Travel Clamp	Two per Slide	N/A		HWH	N/A
Options					
Kit	(Items listed below)	1		8275	
Pump	4-Function, Jacks	1		7239BR	
Jack	12,000 lbs, 16" Stroke	4		7214	
Touch Pad	Located to the right of the drivers seat	1		2318	
Control Box	Attached to bottom of structure	1		2730	
Hose, 60	Pump to Jack, Left Front	2	Brown	2460	
Hose, 228	Pump to Jack, Left Rear	2	Orange	2474	
Hose, 108	Pump to Jack, Right Front	2	White	2464	
Hose, 264	Pump to Jack, Right Rear	1	Yellow	2476	
Hose, 96	Left Rear Jack, Right Rear Jack	1	Yel/Ora.	2463	
Revisions					

**34H KODIAK (19.5) TIRES
EQUALIZER JACKS (FULLY AUTOMATIC)
STANDARD ON THIS UNIT**

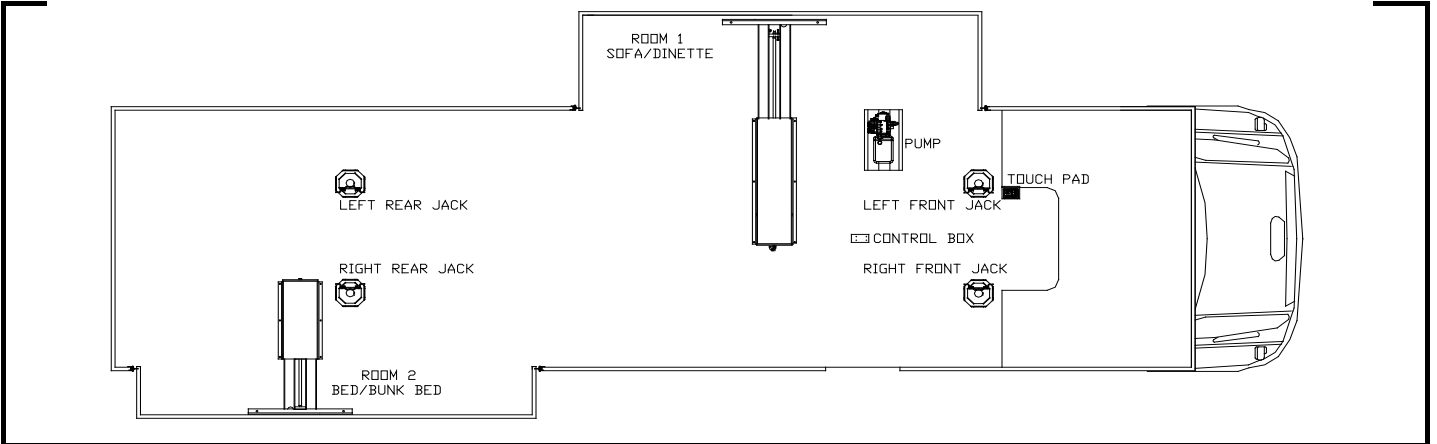

Notes:

1) Jacks mount 2nd hole from top to top mounting plate hole.

Item, Length	Description / Location	Qty	Color	Vendor PN		
Kit	(Items listed below)	1		8341	Measuring from back of cab floor, this is the end location of the hydraulic hoses where they attach to the slide mechanism.	
Pump	6-Function, 2 Room, Jacks	1		7243BR		
Jack	12,000 lbs, 16" Stroke	4		7214		
Touch Pad	Located to the right of the drivers seat	1		2318		
Control Box	Attached to bottom of structure	1		2730		
Hose, 84	Pump to Jack, Left Front	2	Brown	2462		
Hose, 252	Pump to Jack, Left Rear	2	Orange	2587		
Hose, 108	Pump to Jack, Right Front	2	White	2464		
Hose, 252	Pump to Jack, Right Rear	1	Yellow	2587		
Hose, 96	Left Rear Jack, Right Rear Jack	1	Yel/Ora.	2463		
Hose, 84	Pump to Room 1	2	Green	2462		80 / Drivers Side
Slide Unit	Room 1-36" above floor slide	1		7164B		
Hose, 300	Pump to Room 2	2	Purple	2479		245 / Passenger Side
Slide Unit	Room 2-18" above floor slide	1		7135B		
Hose, N/A	Pump to Room 3	N/A	Gray	N/A		N/A
Slide Unit						
Hose, N/A	Pump to Room 4	N/A	Red	N/A	N/A	
Slide Unit						
Travel Clamp	Two per Slide	N/A		HWH	N/A	
Options						
Revisions	Description		By	Date		

**35B KODIAK (19.5) TIRES
EQUALIZER JACKS (FULLY AUTOMATIC)
STANDARD ON THIS UNIT**

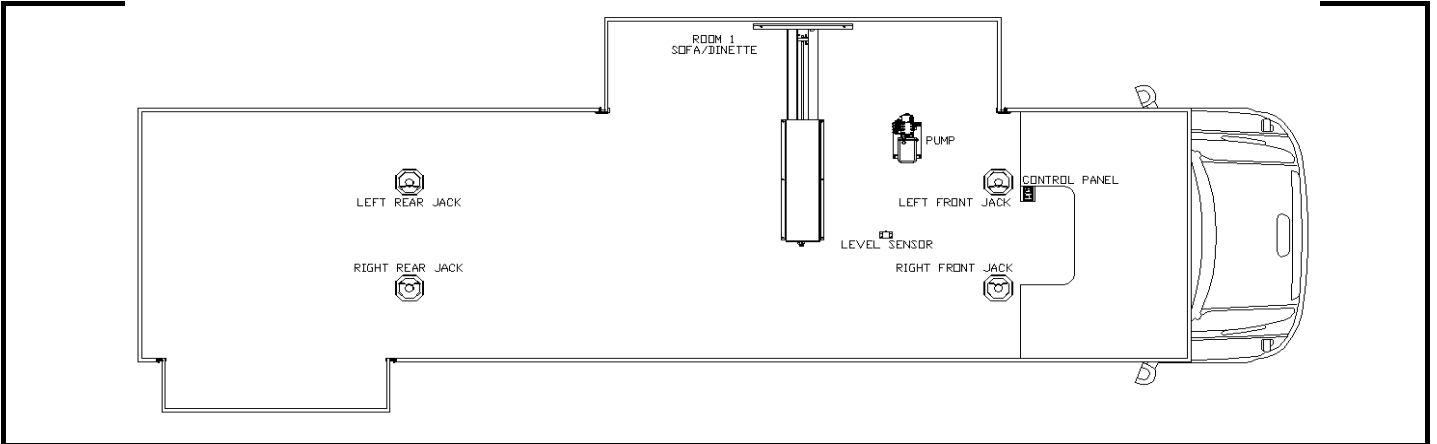

Notes:

1) Jacks mount 2nd hole from top to top mounting plate hole.

Item, Length	Description / Location	Qty	Color	Vendor PN	
Kit	(Items listed below)	1		8264	Measuring from back of cab floor, this is the end location of the hydraulic hoses where they attach to the slide mechanism.
Pump	5-Function, 1 Room, Jacks	1		7242BR	
Jack	12,000 lbs, 16" Stroke	4		7214	
Touch Pad	Located to the right of the drivers seat	1		2318	
Control Box	Attached to bottom of structure	1		2730	
Hose, 72	Pump to Jack, Left Front	2	Brown	2461	
Hose, 240	Pump to Jack, Left Rear	2	Orange	2475	
Hose, 108	Pump to Jack, Right Front	2	White	2464	
Hose, 240	Pump to Jack, Right Rear	1	Yellow	2475	
Hose, 96	Left Rear Jack, Right Rear Jack	1	Yel/Ora.	2463	
Hose, 84	Pump to Room 1	2	Green	2462	80 / Drivers Side
Slide Unit	Room 1-36" above floor slide	1		7164B	
Hose, N/A	Pump to Room 2		Purple		
Slide Unit					
Hose, N/A	Pump to Room 3		Gray		
Slide Unit					
Hose, N/A	Pump to Room 4		Red		
Slide Unit					
Travel Clamp	Two per Slide			HWH	
Options					
Revisions	Description		By	Date	

**34B MAGELLAN (22.5) TIRES
EQUALIZER JACKS (FULLY AUTOMATIC)
STANDARD ON THIS UNIT**

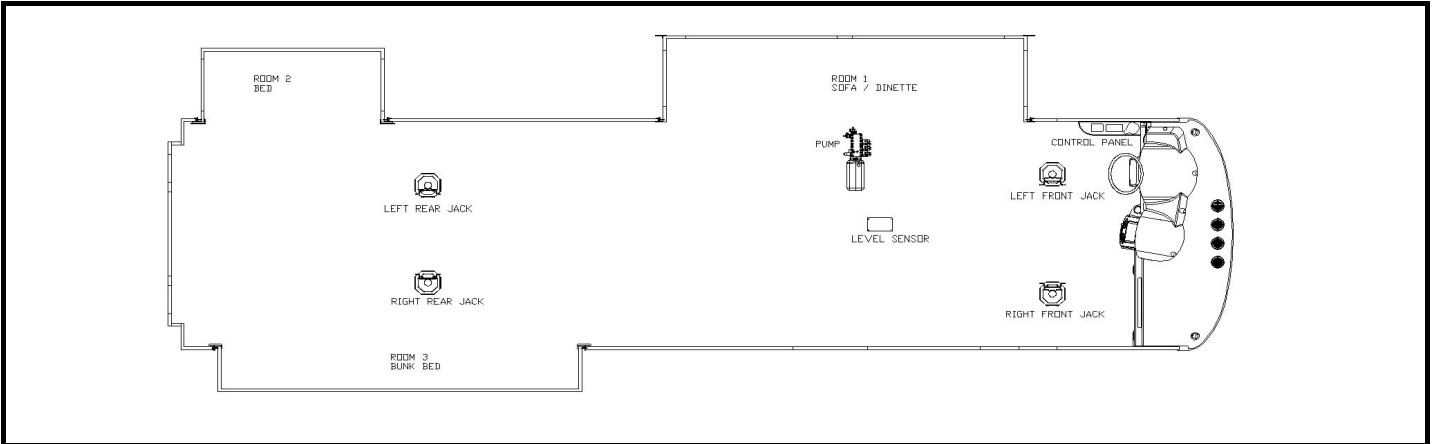

Notes:

- 1) Jacks mount in two different locations on bracket depending on tire size of chassis.
 - a) 19.5 Tires: Top hole in jack to top hole in bracket. Use 4 bolts in welded area of bracket.
 - b) 22.5 Tires: Top hole in jack to second hole in bracket. Use 6 bolts, 4 in welded area of bracket & 2 below welded area.

Item, Length	Description / Location	Qty	Color	Vendor PN	
Kit	(Items listed below)	1		8323	
Pump	7-Function, 3 Rooms & Jacks	1		7301BR	
Jack	12,000 lbs, 16" Stroke	4		7214	
Touch Pad	Located to the left of the drivers seat	1		2318	
Control Box	Attached to bottom of structure	1		2730	
Sync Cylinder	Mounted behind pump compartment	N/A		N/A	
Hose, 132	Pump to Jack, Left Front	2	Brown	2466	
Hose, 240	Pump to Jack, Left Rear	2	Orange	2475	
168	Pump to Jack, Right Front	2	White	2469	
Hose, 264	Pump to Jack, Right Rear	1	Yellow	2476	
Hose, 96	Left Rear Jack, Right Rear Jack	1	Yellow	2463	
Hose, 36	Pump to Room 1	2	Green	2458	127 / Drivers Side
Slide Unit	Room 1-36" Above Floor Slide	1		7164	
Hose, 372	Pump to Room 2	2	Purple	2481	347 / Drivers Side
Slide Unit	Room 2-30" Bed Slide(Lipper)	1		134998	
Hose w90, 372	Pump to Room 3	2	Gray	2481	307 / Passenger Side
Slide Unit	Room 3-18" Above floor slide	1		7135	
Hose, N/A	Pump to Room 4	N/A	Red	N/A	N/A
Travel Clamp	Two per Slide	N/A		N/A	N/A

Measuring from inside of firewall, this is the end location of the hydraulic hoses where they attach to the slide mechanism.

Options

Revisions

1	Update per Equalizer Specs
2	Add Magellan to chart, same as Windsport per ECN 4582.

**36E MAGELLAN (22.5) TIRES
EQUALIZER JACKS (FULLY AUTOMATIC)
STANDARD ON THIS UNIT**

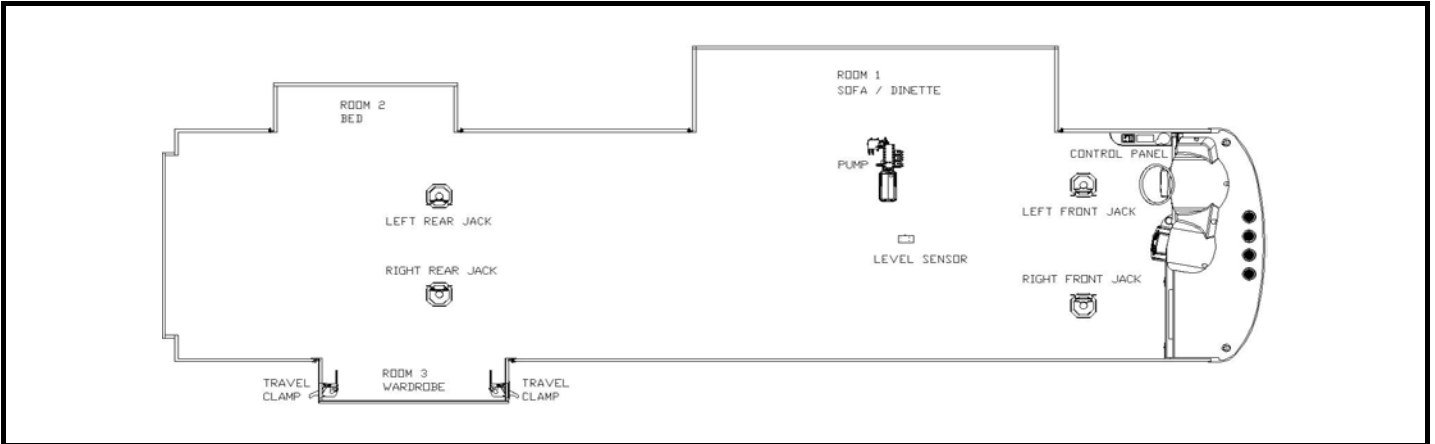

Notes:

- 1) Jacks mount in two different locations on bracket depending on tire size of chassis.
 - a) 19.5 Tires: Top hole in jack to top hole in bracket. Use 4 bolts in welded area of bracket.
 - b) 22.5 Tires: Top hole in jack to second hole in bracket. Use 6 bolts, 4 in welded area of bracket & 2 below welded area.

Item, Length	Description / Location	Qty	Color	Vendor PN	
Kit	(Items listed below)	1		8309	
Pump	7-Function, 3 Rooms & Jacks	1		7301BR	
Jack	12,000 lbs, 16" Stroke	4		7214	
Touch Pad	Located to the left of the drivers seat	1		2318	
Control Box	Attached to bottom of structure	1		2730	
Sync Cylinder	Mounted behind pump compartment	N/A		N/A	
Hose, 120	Pump to Jack, Left Front	2	Brown	2465	
Hose, 240	Pump to Jack, Left Rear	2	Orange	2475	
Hose, 168	Pump to Jack, Right Front	2	White	2469	
Hose, 252	Pump to Jack, Right Rear	1	Yellow	2587	
Hose,96	Left Rear Jack,Right Rear Jack	1	Yel/Ora.	2463	
Hose, 36	Pump to Room 1	2	Green	2458	127 / Drivers Side
Slide Unit	Room 1-36" Above floor slide	1		7164	
Hose, 372	Pump to Room 2	2	Purple	2481	319 / Drivers Side
Slide Unit	Room 2-30" Bed slide(Lippert)	1		134998	
Hose w/90, 372	Pump to Room 3	2	Gray	2481	319 / Passenger Side
Slide Unit	Room 3-18" Above floor slide	1		7135	
Hose, N/A	Pump to Room 4	N/A	Red	N/A	N/A
Travel Clamp	Two per Slide	2		HWH	N/A

Measuring from inside of firewall, this is the end location of the hydraulic hoses where they attach to the slide mechanism.

Options

Revisions

1	New chart for Windsport for MY2007 due to Faux Flat on Rm 1, starting with the schedule released 04/24/06.
2	Update per Equalizer Specs

**36R MAGELLAN (22.5) TIRES
EQUALIZER JACKS (FULLY AUTOMATIC)
STANDARD ON THIS UNIT**

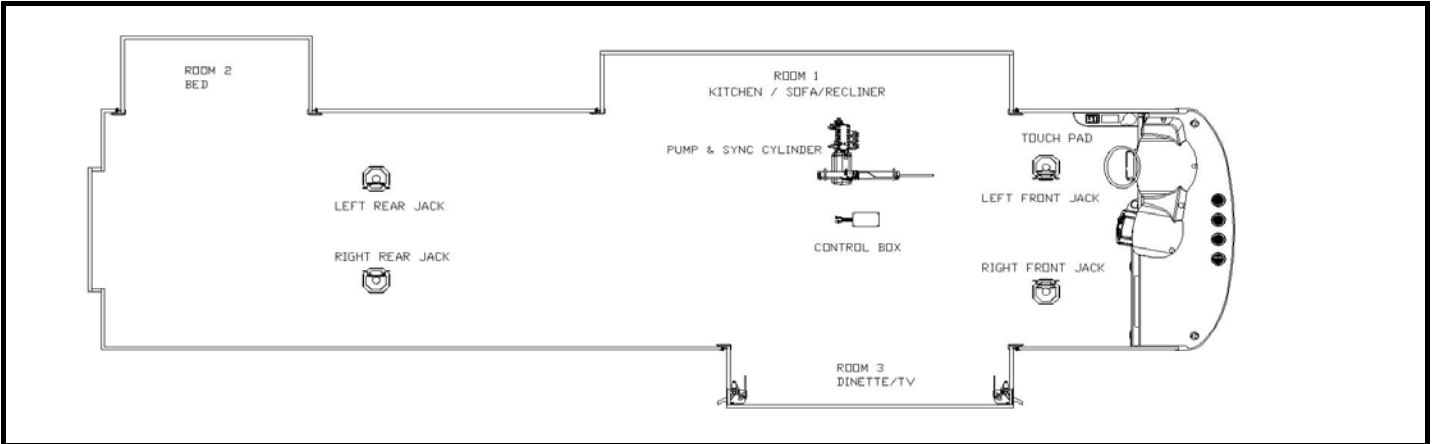

Notes:

- 1) Jacks mount in two different locations on bracket depending on tire size of chassis.
 - a) 19.5 Tires: Top hole in jack to top hole in bracket. Use 4 bolts in welded area of bracket.
 - b) 22.5 Tires: Top hole in jack to second hole in bracket. Use 6 bolts, 4 in welded area of bracket & 2 below welded area.
 - c) Hydraulic hose terminations for room #3 require 90 degree swivel elbows.

Item, Length	Description / Location	Qty	Color	Vendor PN		
Kit	(Items listed below)	1		8342	Measuring from inside of firewall, this is the end location of the hydraulic hoses where they attach to the slide mechanism.	
Pump	7-Function, 3 Rooms & Jacks	1		7301BR		
Jack	12,000 lbs, 16" Stroke	4		7214		
Touch Pad	Located to the left of the drivers seat	1		2318		
Control Box	Attached to bottom of structure	1		2730		
Sync Cylinder	Mounted behind pump compartment	1		7397		
Hose, 120	Pump to Jack, Left Front	2	Brown	2465		
Hose, 240	Pump to Jack, Left Rear	2	Orange	2475		
Hose, 168	Pump to Jack, Right Front	2	White	2469		
Hose, 240	Pump to Jack, Right Rear	1	Yellow	2475		
Hose, 96	Left Rear Jack, Right Rear Jack	1	Yel/Ora.	2463		
Hose, 36	Pump to Room 1	2	Green	2458		127 / Drivers Side
Slide Unit	Room 1- 24" Above Floor slide	1		7369		
Hose, 420	Pump to Room 2	2	Purple	2485		335 / Drivers Side
Slide Unit	Room 2-30" bed slide(Lippert)	1		134998		
Hose, 36	Pump to sync cylinder	2	Gray	2458	Inside pump compartment	
Hose, 120	Sync cylinder to front slide, Room 3	2	Gray	2465	90 / Passenger Side	
Hose, 120	Sync cylinder to rear slide, Room 3	2	Gray	2465	145 / Passenger Side	
Slide Unit	Room 3-24" Flush Floor slide	2		7388		
Hose, N/A	Pump to Room 4	N/A	Red	N/A	N/A	
Travel Clamp	Two per Slide	2		HWH	N/A	

Options

Item, Length	Description / Location	Qty	Color	Vendor PN	

Revisions

1	Update per Equalizer Specs
2	Add Magellan to usage in header per ECN 4582

**36Z MAGELLAN (22.5) TIRES
EQUALIZER JACKS (FULLY AUTOMATIC)
STANDARD ON THIS UNIT**

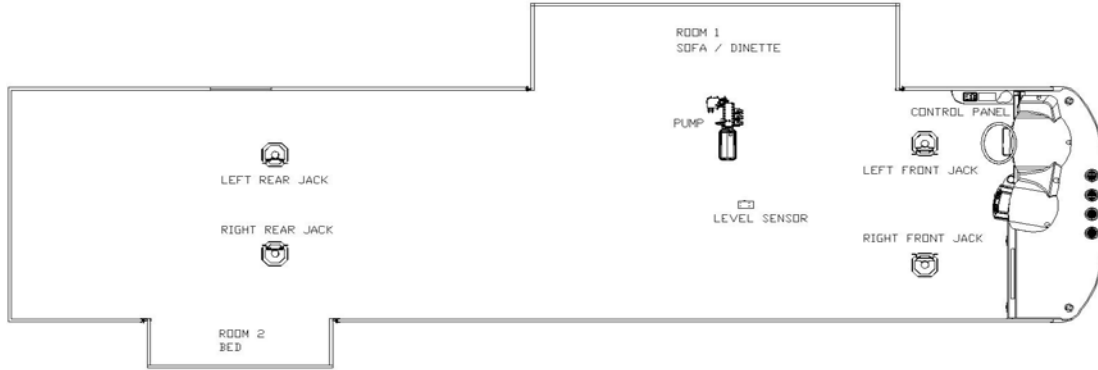

Notes:

1) Jacks mount in two different locations on bracket depending on tire size of chassis.

a) 19.5 Tires: Top hole in jack to top hole in bracket. Use 4 bolts in welded area of bracket.

b) 22.5 Tires: Top hole in jack to second hole in bracket. Use 6 bolts, 4 in welded area of bracket & 2 below welded area.

Item, Length	Description / Location	Qty	Color	Vendor PN	
Kit	(Items listed below)	1		8307	
Pump	6-Function, 2 Rooms & Jacks	1		7243BR	
Jack	12,000 lbs, 16" Stroke	4		7214	
Touch Pad	Located to the left of the drivers seat	1		2318	
Control Box	Attached to bottom of structure	1		2730	
Sync Cylinder	Mounted behind pump compartment	N/A		N/A	
Hose, 120	Pump to Jack, Left Front	2	Brown	2465	
Hose, 228	Pump to Jack, Left Rear	2	Orange	2474	
Hose, 156	Pump to Jack, Right Front	2	White	2468	
Hose, 252	Pump to Jack, Right Rear	1	Yellow	2587	
Hose, 108	Left Rear Jack, Right Rear Jack	1	Yel/Ora	2464	
Hose, 36	Pump to Room 1	2	Green	2458	127 / Drivers Side
Slide Unit	Room 1-36" Above floor slide	1		7164	
Hose, 372	Pump to Room 2	2	Purple	2481	319 / Passenger Side
Slide Unit	Room 2-30" Bed slide(Lippert)	1		134998	
Hose, N/A	Pump to Room 3	N/A	Gray	N/A	N/A
Hose, N/A	Pump to Room 4	N/A	Red	N/A	N/A
Hose, N/A	Pump to Generator Slide	N/A		N/A	N/A
Travel Clamp	Two per Slide	N/A		HWH	N/A

Measuring from inside of firewall, this is the end location of the hydraulic hoses where they attach to the slide mechanism.

Options

Revisions

1	New chart for Windsport for MY2007 due to Faux Flat on Rm 1, starting with the schedule released 04/24/06.
2	Update per Equalizer Specs
3	Add Magellan to usage in header per ECN 4582

**34B MAGELLAN (22.5) TIRES
EQUALIZER JACKS (FULLY AUTOMATIC)
STANDARD ON THIS UNIT**

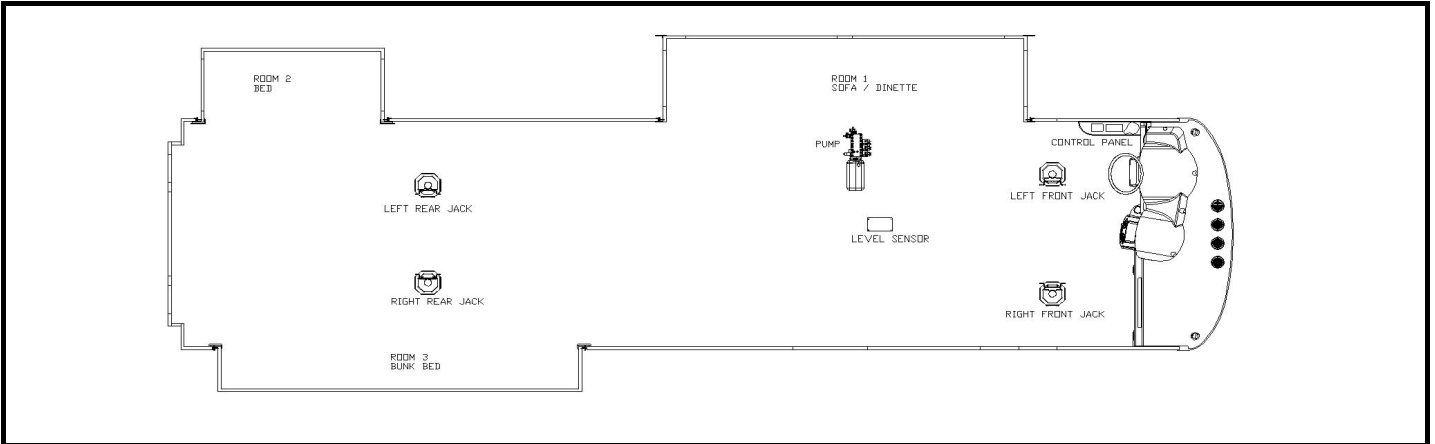

Notes:

- 1) Jacks mount in two different locations on bracket depending on tire size of chassis.
 - a) 19.5 Tires: Top hole in jack to top hole in bracket. Use 4 bolts in welded area of bracket.
 - b) 22.5 Tires: Top hole in jack to second hole in bracket. Use 6 bolts, 4 in welded area of bracket & 2 below welded area.

Item, Length	Description / Location	Qty	Color	Vendor PN	
Kit	(Items listed below)	1		8323	
Pump	7-Function, 3 Rooms & Jacks	1		7301BR	
Jack	12,000 lbs, 16" Stroke	4		7214	
Touch Pad	Located to the left of the drivers seat	1		2318	
Control Box	Attached to bottom of structure	1		2730	
Sync Cylinder	Mounted behind pump compartment	N/A		N/A	
Hose, 132	Pump to Jack, Left Front	2	Brown	2466	
Hose, 240	Pump to Jack, Left Rear	2	Orange	2475	
168	Pump to Jack, Right Front	2	White	2469	
Hose, 264	Pump to Jack, Right Rear	1	Yellow	2476	
Hose, 96	Left Rear Jack, Right Rear Jack	1	Yel/Ora.	2463	
Hose, 36	Pump to Room 1	2	Green	2458	127 / Drivers Side
Slide Unit	Room 1-36" Above Floor Slide	1		7164	
Hose, 372	Pump to Room 2	2	Purple	2481	347 / Drivers Side
Slide Unit	Room 2-30" Bed Slide(Lipper)	1		134998	
Hose w90, 372	Pump to Room 3	2	Gray	2481	307 / Passenger Side
Slide Unit	Room 3-18" Above floor slide	1		7135	
Hose, N/A	Pump to Room 4	N/A	Red	N/A	N/A
Travel Clamp	Two per Slide	N/A		N/A	N/A

Measuring from inside of firewall, this is the end location of the hydraulic hoses where they attach to the slide mechanism.

Options

Revisions

1	Update per Equalizer Specs
2	Add Magellan to chart, same as Windsport per ECN 4582.

**34U MAGELLAN (22.5) TIRES
EQUALIZER JACKS (FULLY AUTOMATIC)
STANDARD ON THIS UNIT**

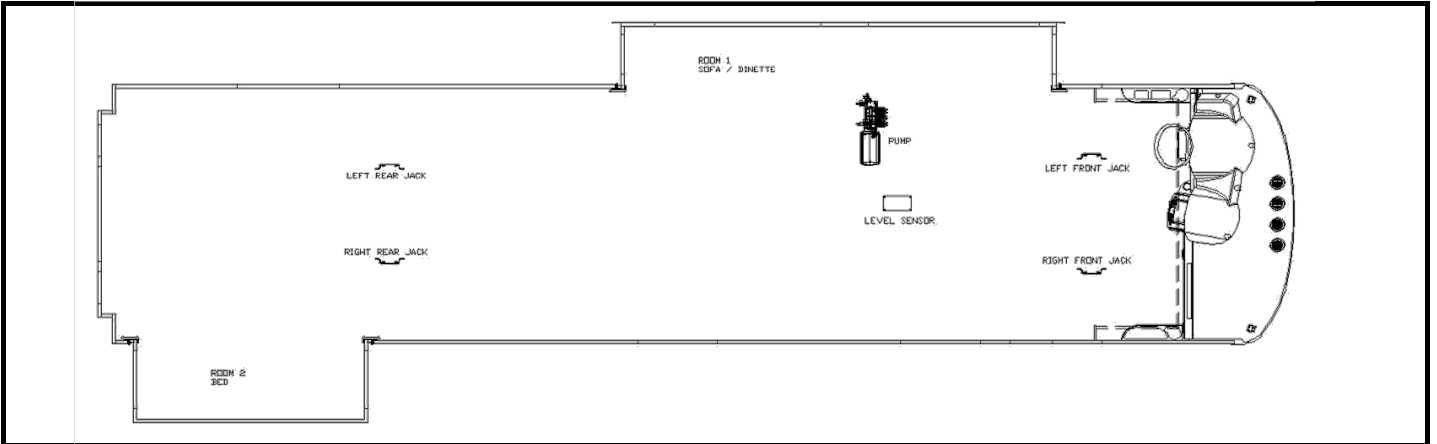

Notes:

- 1) Jacks mount in two different locations on bracket depending on tire size of chassis.
 - a) 19.5 Tires: Top hole in jack to top hole in bracket. Use 4 bolts in welded area of bracket.
 - b) 22.5 Tires: Top hole in jack to second hole in bracket. Use 6 bolts, 4 in welded area of bracket & 2 below welded area.

Item, Length	Description / Location	Qty	Color	Vendor PN		
Kit	(Items listed below)	1		8466		
Pump	6-Function, 2 Rooms & Jacks	1		7243BR		
Jack	12,000 lbs, 16" Stroke	4		7214		
Touch Pad	Located to the left of the drivers seat	1		2318		
Control Box	Attached to bottom of structure	1		2730		
Sync Cylinder	Mounted behind pump compartment	N/A		N/A		
Hose, 132	Pump to Jack, Left Front	2	Brown	2466	Measuring from inside of firewall, this is the end location of the hydraulic hoses where they attach to the slide mechanism.	
Hose, 240	Pump to Jack, Left Rear	2	Orange	2475		
Hose, 168	Pump to Jack, Right Front	2	White	2469		
Hose, 264	Pump to Jack, Right Rear	1	Yellow	2476		
Hose, 96	Left Rear Jack, Right Rear Jack	1	Yel/Ora.	2463		Inside pump compartment
Hose, 36	Pump to Room 1	2	Green	2458		127 / Drivers Side
Slide Unit	Room 1-24" Above Floor Slide	1		7369		N/A
Hose, 372	Pump to Room 2	2	Purple	2481		347 / Passenger Side
Slide Unit	Room 2-30" Bed Slide(Lippert)	1		134998		
Hose, N/A	Pump to Room 3		Gray			
Slide Unit	Room 3-				N/A	
Hose, N/A	Pump to Room 4	N/A	Red	N/A	N/A	
Travel Clamp	Two per Slide	N/A		N/A	N/A	

Options

Revisions

**36E MAGELLAN (22.5) TIRES
EQUALIZER JACKS (FULLY AUTOMATIC)
STANDARD ON THIS UNIT**

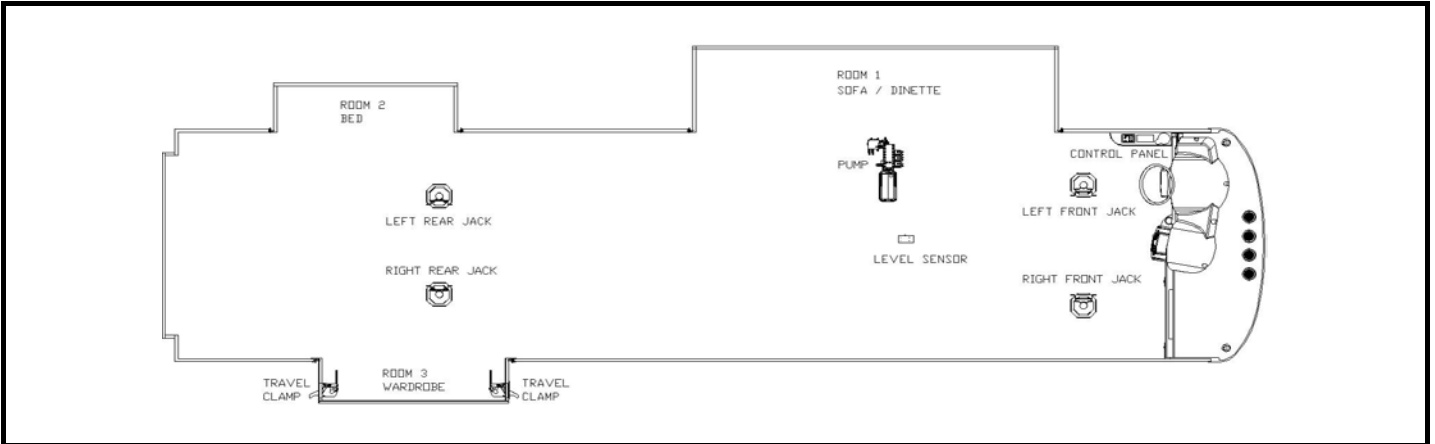

Notes:

1) Jacks mount in two different locations on bracket depending on tire size of chassis.

a) 19.5 Tires: Top hole in jack to top hole in bracket. Use 4 bolts in welded area of bracket.

b) 22.5 Tires: Top hole in jack to second hole in bracket. Use 6 bolts, 4 in welded area of bracket & 2 below welded area.

Item, Length	Description / Location	Qty	Color	Vendor PN	
Kit	(Items listed below)	1		8309	
Pump	7-Function, 3 Rooms & Jacks	1		7301BR	
Jack	12,000 lbs, 16" Stroke	4		7214	
Touch Pad	Located to the left of the drivers seat	1		2318	
Control Box	Attached to bottom of structure	1		2730	
Sync Cylinder	Mounted behind pump compartment	N/A		N/A	
Hose, 120	Pump to Jack, Left Front	2	Brown	2465	
Hose, 240	Pump to Jack, Left Rear	2	Orange	2475	
Hose, 168	Pump to Jack, Right Front	2	White	2469	
Hose, 252	Pump to Jack, Right Rear	1	Yellow	2587	
Hose,96	Left Rear Jack,Right Rear Jack	1	Yel/Ora.	2463	
Hose, 36	Pump to Room 1	2	Green	2458	127 / Drivers Side
Slide Unit	Room 1-36" Above floor slide	1		7164	
Hose, 372	Pump to Room 2	2	Purple	2481	319 / Drivers Side
Slide Unit	Room 2-30" Bed slide(Lippert)	1		134998	
Hose w/90, 372	Pump to Room 3	2	Gray	2481	319 / Passenger Side
Slide Unit	Room 3-18" Above floor slide	1		7135	
Hose, N/A	Pump to Room 4	N/A	Red	N/A	N/A
Travel Clamp	Two per Slide	2		HWH	N/A

Measuring from inside of firewall, this is the end location of the hydraulic hoses where they attach to the slide mechanism.

Options

Revisions

1	New chart for Windsport for MY2007 due to Faux Flat on Rm 1, starting with the schedule released 04/24/06.
2	Update per Equalizer Specs

**36R MAGELLAN (22.5) TIRES
EQUALIZER JACKS (FULLY AUTOMATIC)
STANDARD ON THIS UNIT**

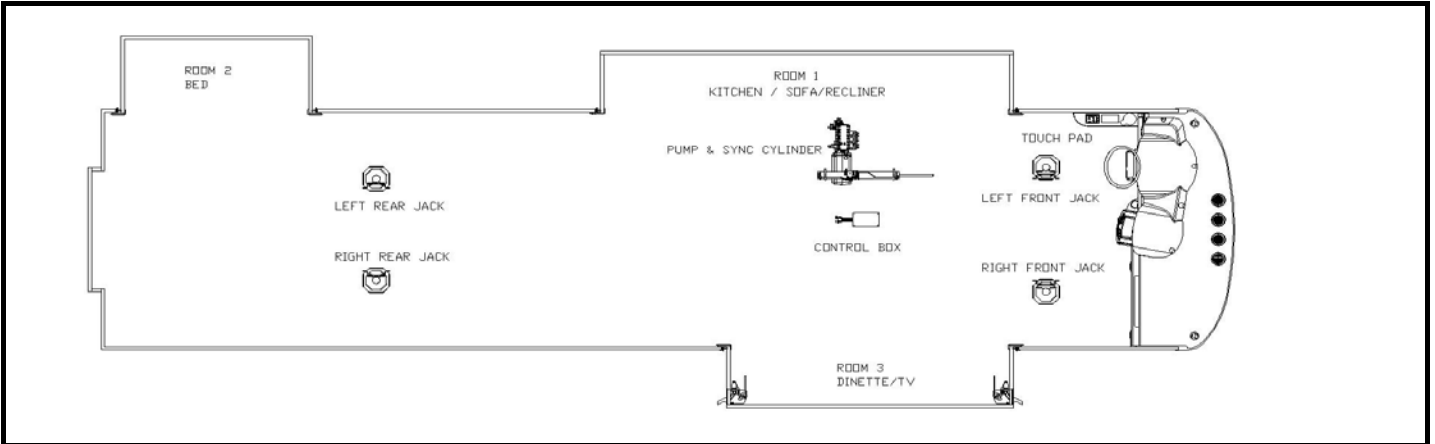

Notes:

- 1) Jacks mount in two different locations on bracket depending on tire size of chassis.
 - a) 19.5 Tires: Top hole in jack to top hole in bracket. Use 4 bolts in welded area of bracket.
 - b) 22.5 Tires: Top hole in jack to second hole in bracket. Use 6 bolts, 4 in welded area of bracket & 2 below welded area.
 - c) Hydraulic hose terminations for room #3 require 90 degree swivel elbows.

Item, Length	Description / Location	Qty	Color	Vendor PN		
Kit	(Items listed below)	1		8342	Measuring from inside of firewall, this is the end location of the hydraulic hoses where they attach to the slide mechanism.	
Pump	7-Function, 3 Rooms & Jacks	1		7301BR		
Jack	12,000 lbs, 16" Stroke	4		7214		
Touch Pad	Located to the left of the drivers seat	1		2318		
Control Box	Attached to bottom of structure	1		2730		
Sync Cylinder	Mounted behind pump compartment	1		7397		
Hose, 120	Pump to Jack, Left Front	2	Brown	2465		
Hose, 240	Pump to Jack, Left Rear	2	Orange	2475		
Hose, 168	Pump to Jack, Right Front	2	White	2469		
Hose, 240	Pump to Jack, Right Rear	1	Yellow	2475		
Hose, 96	Left Rear Jack, Right Rear Jack	1	Yel/Ora.	2463		
Hose, 36	Pump to Room 1	2	Green	2458		127 / Drivers Side
Slide Unit	Room 1- 24" Above Floor slide	1		7369		
Hose, 420	Pump to Room 2	2	Purple	2485		335 / Drivers Side
Slide Unit	Room 2-30" bed slide(Lippert)	1		134998		
Hose, 36	Pump to sync cylinder	2	Gray	2458	Inside pump compartment	
Hose, 120	Sync cylinder to front slide, Room 3	2	Gray	2465	90 / Passenger Side	
Hose, 120	Sync cylinder to rear slide, Room 3	2	Gray	2465	145 / Passenger Side	
Slide Unit	Room 3-24" Flush Floor slide	2		7388		
Hose, N/A	Pump to Room 4	N/A	Red	N/A	N/A	
Travel Clamp	Two per Slide	2		HWH	N/A	

Options

Item, Length	Description / Location	Qty	Color	Vendor PN	

Revisions

1	Update per Equalizer Specs
2	Add Magellan to usage in header per ECN 4582

**36Z MAGELLAN (22.5) TIRES
EQUALIZER JACKS (FULLY AUTOMATIC)
STANDARD ON THIS UNIT**

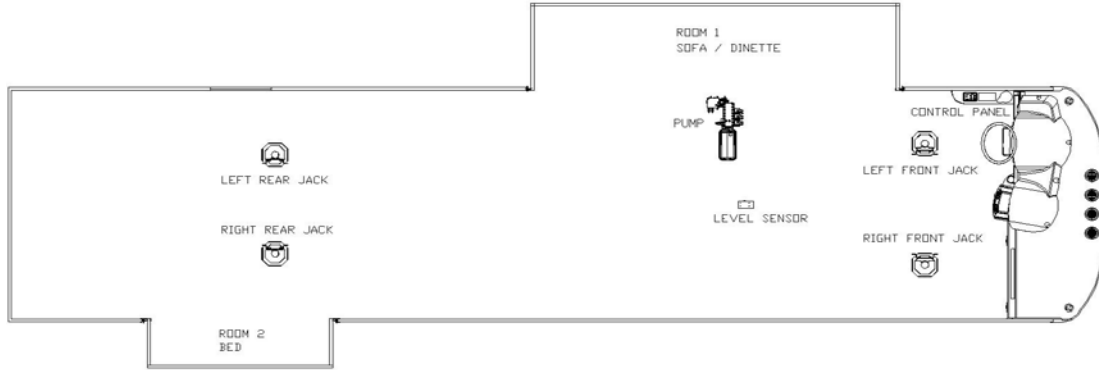

Notes:

1) Jacks mount in two different locations on bracket depending on tire size of chassis.

a) 19.5 Tires: Top hole in jack to top hole in bracket. Use 4 bolts in welded area of bracket.

b) 22.5 Tires: Top hole in jack to second hole in bracket. Use 6 bolts, 4 in welded area of bracket & 2 below welded area.

Item, Length	Description / Location	Qty	Color	Vendor PN	
Kit	(Items listed below)	1		8307	
Pump	6-Function, 2 Rooms & Jacks	1		7243BR	
Jack	12,000 lbs, 16" Stroke	4		7214	
Touch Pad	Located to the left of the drivers seat	1		2318	
Control Box	Attached to bottom of structure	1		2730	
Sync Cylinder	Mounted behind pump compartment	N/A		N/A	
Hose, 120	Pump to Jack, Left Front	2	Brown	2465	
Hose, 228	Pump to Jack, Left Rear	2	Orange	2474	
Hose, 156	Pump to Jack, Right Front	2	White	2468	
Hose, 252	Pump to Jack, Right Rear	1	Yellow	2587	
Hose, 108	Left Rear Jack, Right Rear Jack	1	Yel/Ora	2464	
Hose, 36	Pump to Room 1	2	Green	2458	127 / Drivers Side
Slide Unit	Room 1-36" Above floor slide	1		7164	
Hose, 372	Pump to Room 2	2	Purple	2481	319 / Passenger Side
Slide Unit	Room 2-30" Bed slide(Lippert)	1		134998	
Hose, N/A	Pump to Room 3	N/A	Gray	N/A	N/A
Hose, N/A	Pump to Room 4	N/A	Red	N/A	N/A
Hose, N/A	Pump to Generator Slide	N/A		N/A	N/A
Travel Clamp	Two per Slide	N/A		HWH	N/A

Measuring from inside of firewall, this is the end location of the hydraulic hoses where they attach to the slide mechanism.

Options

Revisions

1	New chart for Windsport for MY2007 due to Faux Flat on Rm 1, starting with the schedule released 04/24/06.
2	Update per Equalizer Specs
3	Add Magellan to usage in header per ECN 4582

**30Q WINDSPORT (19.5) TIRES
EQUALIZER JACKS (FULLY AUTOMATIC)
OPTIONAL ON THIS UNIT**



Notes:

1) Jacks mount in two different locations on bracket depending on tire size of chassis.

a) 19.5 Tires: Top hole in jack to top hole in bracket. Use 4 bolts in welded area of bracket.

b) 22.5 Tires: Top hole in jack to second hole in bracket. Use 6 bolts, 4 in welded area of bracket & 2 below welded area.

Item, Length	Description / Location	Qty	Color	Vendor PN	
Kit	(Items listed below)	1		8252	Measuring from inside of firewall, this is the end location of the hydraulic hoses where they attach to the slide mechanism.
Pump	4-Function, Jacks	1		7239BR	
Jack	12,000 lbs, 16" Stroke	4		7214	
Touch Pad	Located to the left of the drivers seat	1		2318	
Control Box	Attached to bottom of structure	1		2730	
Sync Cylinder	Mounted behind pump compartment	N/A		N/A	
Hose, 132	Pump to Jack, Left Front	2	Brown	2466	
Hose, 216	Pump to Jack, Left Rear	2	Orange	2473	
Hose, 180	Pump to Jack, Right Front	1	White	2470	
Hose, 264	Pump to Jack, Right Rear	1	Yellow	2476	
Hose, 96	Left Front Jack, Right Front Jack	1	Whi/Brn.	2463	
Hose, 96	Left Rear Jack, Right Rear Jack	1	Yel/Ora.	2463	
Hose, N/A	Pump to sync cylinder	N/A		N/A	
Hose, N/A	Sync cylinder to front slide, Room 1	N/A		N/A	
Hose, N/A	Sync cylinder to rear slide, Room 1	N/A		N/A	
Hose, N/A	Pump to Room 1	N/A		N/A	
Hose, N/A	Pump to Room 2	N/A		N/A	
Hose, N/A	Pump to Room 3	N/A		N/A	
Hose, N/A	Pump to Room 4	N/A		N/A	
Hose, N/A	Pump to Generator Slide	N/A		N/A	
Travel Clamp	Two per Slide	N/A		N/A	
Options					
Revisions					
1	New chart for Windsport for MY2007 due to Faux Flat on Rm 1, starting with the schedule released 04/24/06.				
2	Update per Equalizer Specs				

**31D WINDSPORT (19.5) TIRES
EQUALIZER JACKS (FULLY AUTOMATIC)
OPTIONAL ON THIS UNIT**

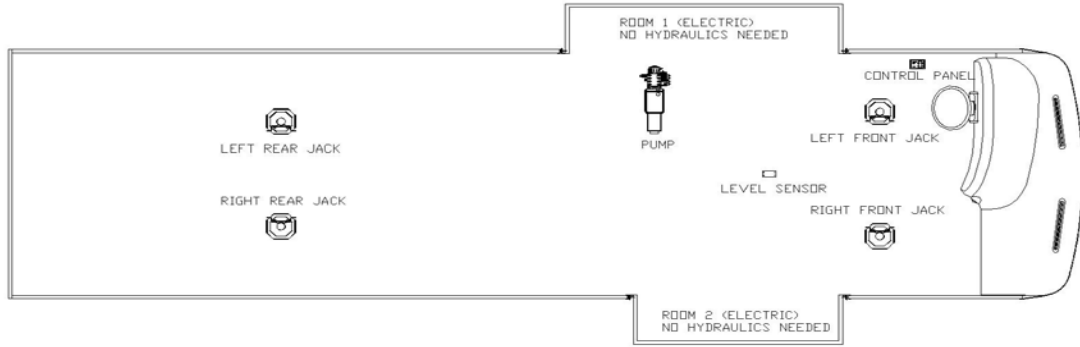

Notes:

- 1) Jacks mount in two different locations on bracket depending on tire size of chassis.
 - a) 19.5 Tires: Top hole in jack to top hole in bracket. Use 4 bolts in welded area of bracket.
 - b) 22.5 Tires: Top hole in jack to second hole in bracket. Use 6 bolts, 4 in welded area of bracket & 2 below welded area.

Item, Length	Description / Location	Qty	Color	Vendor PN	
Kit	(Items listed below)	1		8252	Measuring from inside of firewall, this is the end location of the hydraulic hoses where they attach to the slide mechanism.
Pump	4-Function, Jacks	1		7239BR	
Jack	12,000 lbs, 16" Stroke	4		7214	
Touch Pad	Located to the left of the drivers seat	1		2318	
Control Box	Attached to bottom of structure	1		2730	
Sync Cylinder	Mounted behind pump compartment	N/A		N/A	
Hose, 132	Pump to Jack, Left Front	2	Brown	2466	
Hose, 216	Pump to Jack, Left Rear	2	Orange	2473	
Hose, 180	Pump to Jack, Right Front	1	White	2470	
Hose, 264	Pump to Jack, Right Rear	1	Yellow	2476	
Hose, 96	Left Front Jack, Right Front Jack	1	Whi/Brn.	2463	
Hose, 96	Left Rear Jack, Right Rear Jack	1	Yel/Ora.	2463	
Hose, N/A	Pump to sync cylinder	N/A		N/A	
Hose, N/A	Sync cylinder to front slide, Room 1	N/A		N/A	
Hose, N/A	Sync cylinder to rear slide, Room 1	N/A		N/A	
Hose, N/A	Pump to Room 1	N/A		N/A	
Hose, N/A	Pump to Room 2	N/A		N/A	
Hose, N/A	Pump to Room 3	N/A		N/A	
Hose, N/A	Pump to Room 4	N/A		N/A	
Hose, N/A	Pump to Generator Slide	N/A		N/A	
Travel Clamp	Two per Slide	N/A		N/A	
Options					
Revisions					
1	New chart for Windsport for MY2007 due to Faux Flat on Rm 1, starting with the schedule released 04/24/06.				
2	Update per Equalizer Specs				

**32E WINDSPORT (19.5) TIRES
EQUALIZER JACKS (FULLY AUTOMATIC)
OPTIONAL ON THIS UNIT**

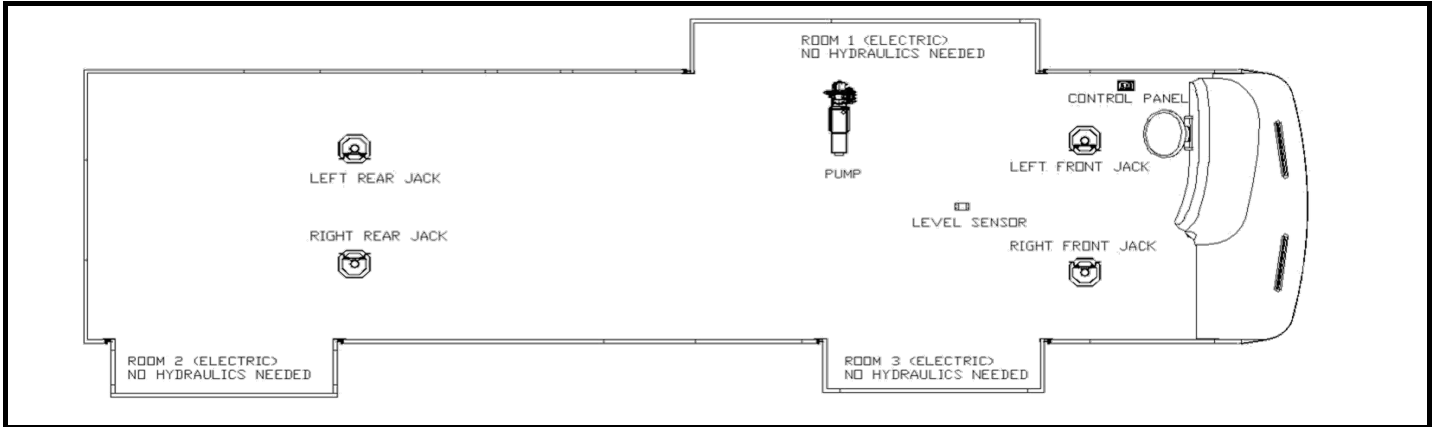

Notes:

- 1) Jacks mount in two different locations on bracket depending on tire size of chassis.
 - a) 19.5 Tires: Top hole in jack to top hole in bracket. Use 4 bolts in welded area of bracket.
 - b) 22.5 Tires: Top hole in jack to second hole in bracket. Use 6 bolts, 4 in welded area of bracket & 2 below welded area.

Item, Length	Description / Location	Qty	Color	Vendor PN	
Kit	(Items listed below)	1		8252	Measuring from inside of firewall, this is the end location of the hydraulic hoses where they attach to the slide mechanism.
Pump	4-Function, Jacks	1		7239BR	
Jack	12,000 lbs, 16" Stroke	4		7214	
Touch Pad	Located to the left of the drivers seat	1		2318	
Control Box	Attached to bottom of structure	1		2730	
Sync Cylinder	Mounted behind pump compartment	N/A		N/A	
Hose, 132	Pump to Jack, Left Front	2	Brown	2466	
Hose, 216	Pump to Jack, Left Rear	2	Orange	2473	
Hose, 180	Pump to Jack, Right Front	1	White	2470	
Hose, 264	Pump to Jack, Right Rear	1	Yellow	2476	
Hose, 96	Left Front Jack, Right Front Jack	1	Whi/Brn.	2463	
Hose, 96	Left Rear Jack, Right Rear Jack	1	Yel/Ora.	2463	
Hose, N/A	Pump to sync cylinder	N/A		N/A	
Hose, N/A	Sync cylinder to front slide, Room 1	N/A		N/A	
Hose, N/A	Sync cylinder to rear slide, Room 1	N/A		N/A	
Hose, N/A	Pump to Room 1	N/A		N/A	
Hose, N/A	Pump to Room 2	N/A		N/A	
Hose, N/A	Pump to Room 3	N/A		N/A	
Hose, N/A	Pump to Room 4	N/A		N/A	
Hose, N/A	Pump to Generator Slide	N/A		N/A	
Travel Clamp	Two per Slide	N/A		N/A	
Options					
Revisions					
1	New chart for Windsport for MY2007 due to Faux Flat on Rm 1, starting with the schedule released 04/24/06.				
2	Update per Equalizer Specs				

**33T WINDSPORT (19.5) TIRES
EQUALIZER JACKS (FULLY AUTOMATIC)
OPTIONAL ON THIS UNIT**

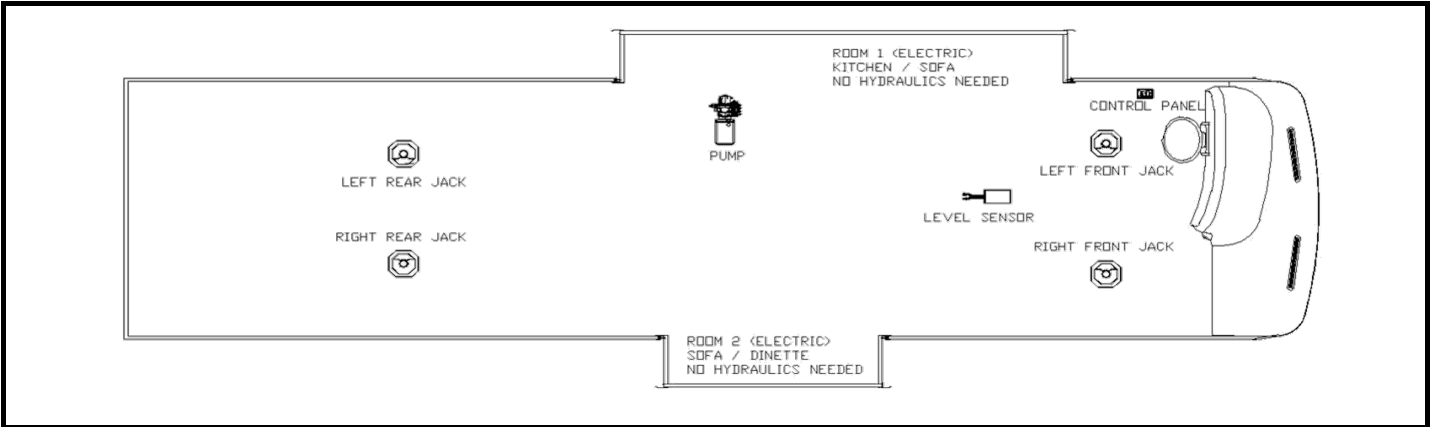

Notes:

- 1) Jacks mount in two different locations on bracket depending on tire size of chassis.
 a) 19.5 Tires: Top hole in jack to top hole in bracket. Use 4 bolts in welded area of bracket.
 b) 22.5 Tires: Top hole in jack to second hole in bracket. Use 6 bolts, 4 in welded area of bracket & 2 below welded area.

Item, Length	Description / Location	Qty	Color	Vendor PN		
Kit	(Items listed below)	1		8381	Measuring from inside of firewall, this is the end location of the hydraulic hoses where they attach to the slide mechanism.	
Pump	4-Function, Jacks	1		7239BR		
Jack	12,000 lbs, 16" Stroke	4		7214		
Touch Pad	Located to the left of the drivers seat	1		2318		
Control Box	Attached to bottom of structure	1		2730		
Flow Divider	Mounted behind pump compartment	N/A		N/A		
Hose, 204	Pump to Jack, Left Front	2	Brown	2472		
Hose, 180	Pump to Jack, Left Rear	2	Orange	2470		
Hose, 252	Pump to Jack, Right Front	1	White	2587		
Hose, 216	Pump to Jack, Right Rear	1	Yellow	2473		
Hose, 96	Left Front Jack, Right Front Jack	1	Whi/Brn.	2463		
Hose, 96	Left Rear Jack, Right Rear Jack	1	Yel/Ora.	2463		
Hose, N/A	Pump to Flow Divider	N/A	N/A	N/A		N/A
Hose, N/A	Flow divider to front slide, Room 1	N/A	N/A	N/A		N/A
Hose, N/A	Flow divider to rear slide, Room 1	N/A	N/A	N/A	N/A	
Hose, N/A	Pump to Room 1	N/A	Green	N/A	N/A	
Hose, N/A	Pump to Room 2	N/A	Purple	N/A	N/A	
Hose, N/A	Pump to Room 3	N/A	Gray	N/A	N/A	
Hose, N/A	Pump to Room 4	N/A	Red	N/A	N/A	
Hose, N/A	Pump to Generator Slide	N/A	TBD	N/A	N/A	
Travel Clamp	Two per Slide	N/A		HWH	N/A	
Options						
Revisions						
1	New chart for Windsport for MY2007 due to Faux Flat on Rm 1, starting with the schedule released 04/24/06.					
2	Update per Equalizer Specs					

**32R WINDSPORT (22.5) TIRES
EQUALIZER JACKS (FULLY AUTOMATIC)
STANDARD ON THIS UNIT**

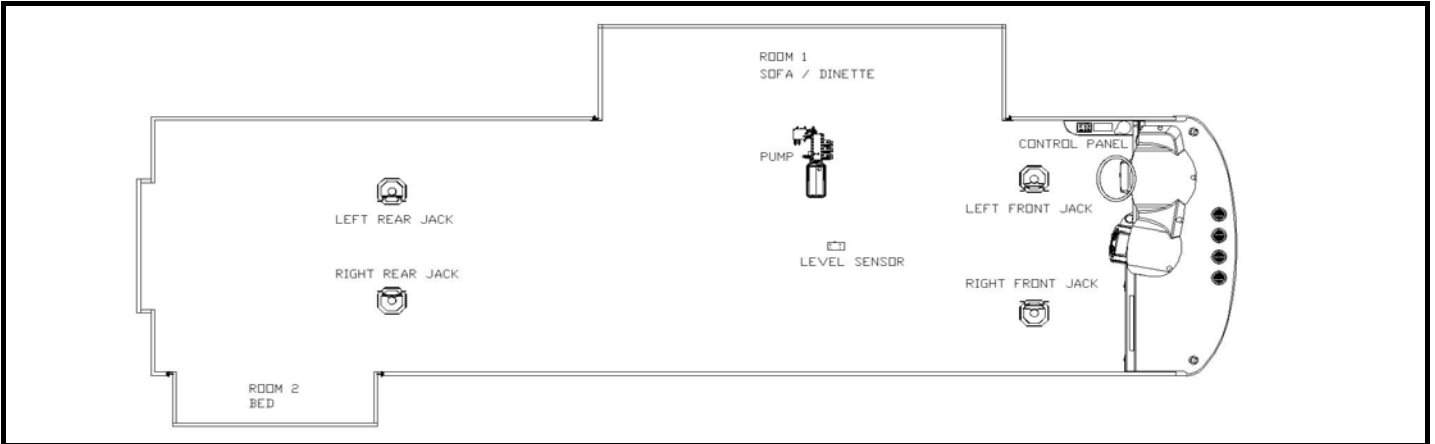

Notes:

1) Jacks mount in two different locations on bracket depending on tire size of chassis.

a) 19.5 Tires: Top hole in jack to top hole in bracket. Use 4 bolts in welded area of bracket.

b) 22.5 Tires: Top hole in jack to second hole in bracket. Use 6 bolts, 4 in welded area of bracket & 2 below welded area.

Item, Length	Description / Location	Qty	Color	Vendor PN	
Kit	(Items listed below)	1		8308	Measuring from inside of firewall, this is the end location of the hydraulic hoses where they attach to the slide mechanism.
Pump	6-Function, 2 Rooms & Jacks	1		7243BR	
Jack	12,000 lbs, 16" Stroke	4		7214	
Touch Pad	Located to the left of the drivers seat	1		2318	
Control Box	Attached to bottom of structure	1		2730	
Sync Cylinder	Mounted behind pump compartment	N/A		N/A	
Hose, 144	Pump to Jack, Left Front	2	Brown	2467	
Hose, 240	Pump to Jack, Left Rear	2	Orange	2475	
Hose, 180	Pump to Jack, Right Front	1	White	2470	
Hose, 288	Pump to Jack, Right Rear	1	Yellow	2478	
Hose, 96	Left Front Jack, Right Front Jack	1	White	2463	
Hose, 96	Left Rear Jack, Right Rear Jack	1	Yellow	2463	
Hose, N/A	Pump to sync cylinder	N/A	Green	N/A	Inside pump compartment
Hose, N/A	Sync cylinder to front slide, Room 1	N/A	Green	N/A	N/A
Hose, N/A	Sync cylinder to rear slide, Room 1	N/A	Green	N/A	N/A
Hose, 36	Pump to Room 1	2	Green	2458	127 / Drivers Side
Slide Unit	Room 1-36" Above floor slide	1		7164	
Hose, 372	Pump to Room 2	2	Purple	2481	310 / Passenger Side
Slide Unit	Room 2-30" Bed Slide (Lippert)	1		134998	
Hose, N/A	Pump to Room 3	N/A	Gray	N/A	N/A
Slide Unit					
Hose, N/A	Pump to Room 4	N/A	Red	N/A	N/A
Slide Unit					
Travel Clamp	Two per Slide	N/A		HWH	N/A

Options

Revisions

1	New chart for Windsport for MY2007 due to Faux Flat on Rm 1, starting with the schedule released 04/24/06.
2	Update per Equalizer Specs

**34B WINDSPORT/MAGELLAN (22.5) TIRES
EQUALIZER JACKS (FULLY AUTOMATIC)
STANDARD ON THIS UNIT**

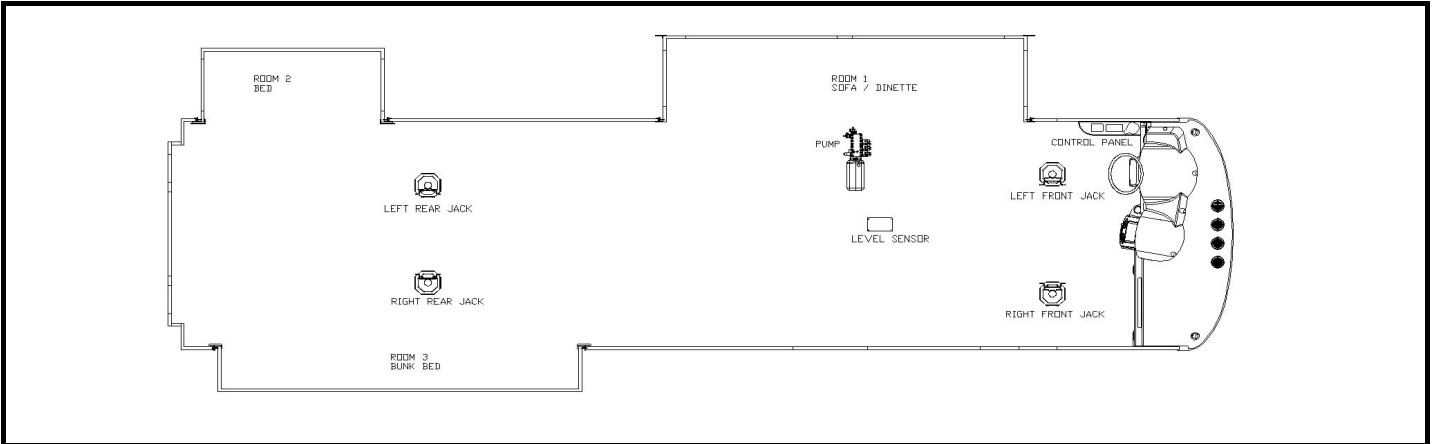

Notes:

- 1) Jacks mount in two different locations on bracket depending on tire size of chassis.
 - a) 19.5 Tires: Top hole in jack to top hole in bracket. Use 4 bolts in welded area of bracket.
 - b) 22.5 Tires: Top hole in jack to second hole in bracket. Use 6 bolts, 4 in welded area of bracket & 2 below welded area.

Item, Length	Description / Location	Qty	Color	Vendor PN	
Kit	(Items listed below)	1		8323	
Pump	7-Function, 3 Rooms & Jacks	1		7301BR	
Jack	12,000 lbs, 16" Stroke	4		7214	
Touch Pad	Located to the left of the drivers seat	1		2318	
Control Box	Attached to bottom of structure	1		2730	
Sync Cylinder	Mounted behind pump compartment	N/A		N/A	
Hose, 132	Pump to Jack, Left Front	2	Brown	2466	
Hose, 240	Pump to Jack, Left Rear	2	Orange	2475	
168	Pump to Jack, Right Front	2	White	2469	
Hose, 264	Pump to Jack, Right Rear	1	Yellow	2476	
Hose, 96	Left Rear Jack, Right Rear Jack	1	Yellow	2463	
Hose, 36	Pump to Room 1	2	Green	2458	127 / Drivers Side
Slide Unit	Room 1-36" Above Floor Slide	1		7164	
Hose, 372	Pump to Room 2	2	Purple	2481	347 / Drivers Side
Slide Unit	Room 2-30" Bed Slide(Lipper)	1		134998	
Hose w90, 372	Pump to Room 3	2	Gray	2481	307 / Passenger Side
Slide Unit	Room 3-18" Above floor slide	1		7135	
Hose, N/A	Pump to Room 4	N/A	Red	N/A	N/A
Travel Clamp	Two per Slide	N/A		N/A	N/A

Measuring from inside of firewall, this is the end location of the hydraulic hoses where they attach to the slide mechanism.

Options

Revisions

1	Update per Equalizer Specs
2	Add Magellan to chart, same as Windsport per ECN 4582.

**34Y WINDSPORT (19.5) TIRES
EQUALIZER JACKS (FULLY AUTOMATIC)
STANDARD ON THIS UNIT**

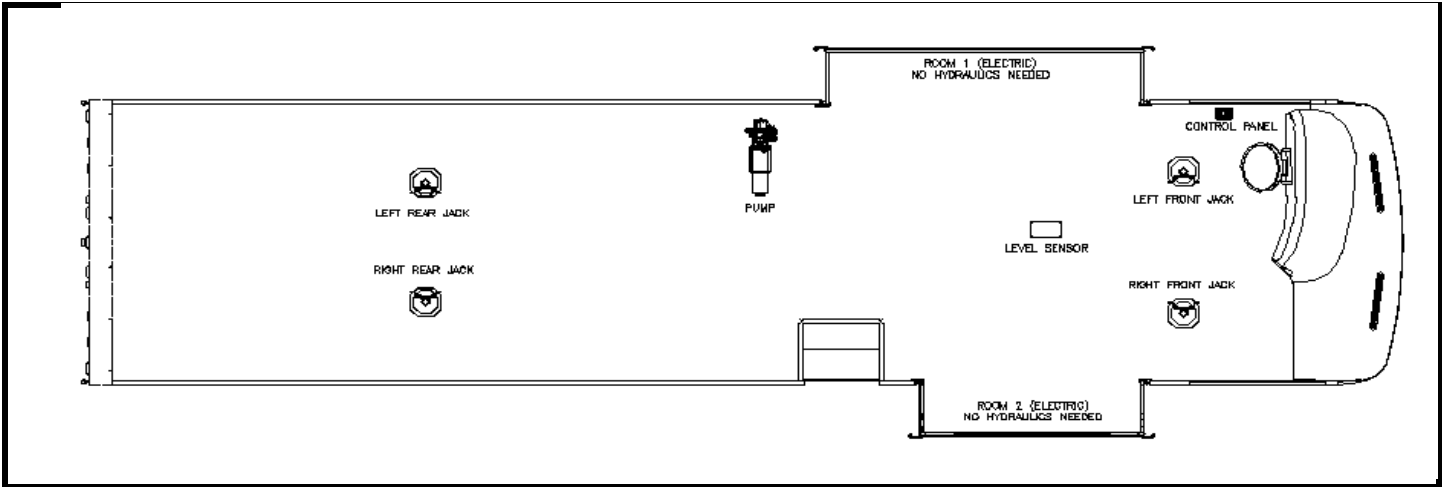

Notes:

1) Jacks mount 2nd hole from top to top mounting plate hole.

Item, Length	Description / Location	Qty	Color	Vendor PN		
Kit	(Items listed below)	1		8365	Measuring from back of cab floor, this is the end location of the hydraulic hoses where they attach to the slide mechanism.	
Pump	4-Function, Jacks Only	1		7239BR		
Jack	12,000 lbs, 16" Stroke	4		7214		
Touch Pad	Located to the left of the drivers seat	1		2318		
Control Box	Attached to bottom of structure	1		2730		
Sync Cylinder	Mounted behind pump compartment	N/A		N/A		
Hose, 180	Pump to Jack, Left Front	2	Brown	2470		
Hose, 180	Pump to Jack, Left Rear	2	Orange	2470		
Hose, 216	Pump to Jack, Right Front	1	White	2473		
Hose, 180	Pump to Jack, Right Rear	1	Yellow	2470		
Hose, 96	Left Front Jack, Right Front Jack	1	Whi/Brn.	2463		
Hose, 96	Left Rear Jack, Right Rear Jack	1	Yel/Ora.	2463		
Hose, N/A	Pump to Flow Divider	N/A	N/A	N/A		N/A
Hose, N/A	Flow divider to front slide, Room 1	N/A	N/A	N/A		N/A
Hose, N/A	Flow divider to rear slide, Room 1	N/A	N/A	N/A		N/A
Hose, N/A	Pump to Room 1	N/A	Green	N/A		N/A
Hose, N/A	Pump to Room 2	N/A	Purple	N/A		N/A
Hose, N/A	Pump to Room 3	N/A	Gray	N/A		N/A
Hose, N/A	Pump to Room 4	N/A	Red	N/A		N/A
Hose, N/A	Pump to Generator Slide	N/A	TBD	N/A		N/A
Travel Clamp	Two per Slide	N/A		HWH	N/A	
Options						
Revisions						
1	Update per Equalizer Specs					

**36E WINDSPORT/MAGELLAN (22.5) TIRES
EQUALIZER JACKS (FULLY AUTOMATIC)
STANDARD ON THIS UNIT**

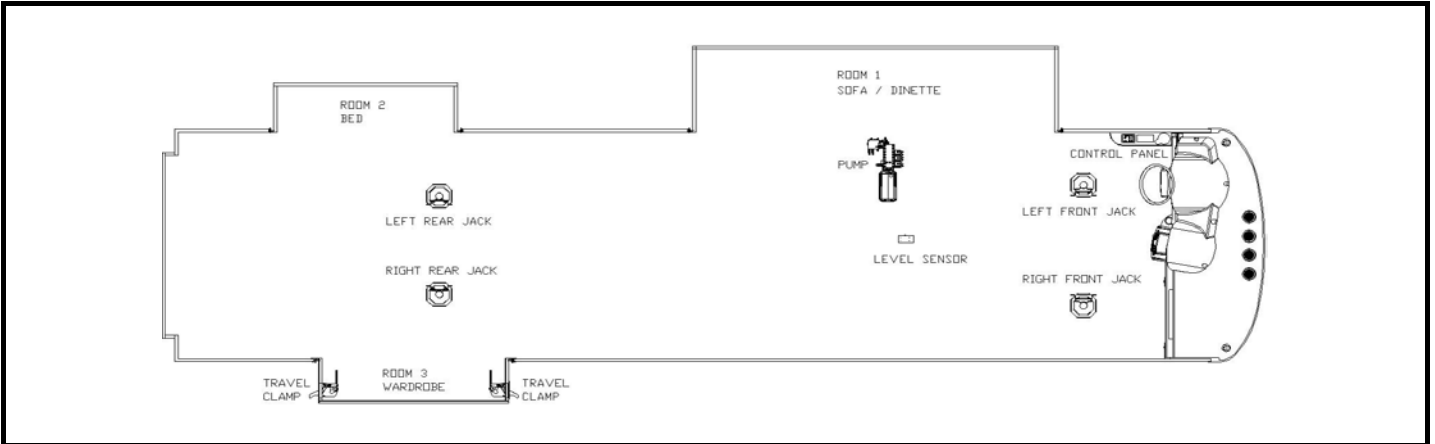

Notes:

- 1) Jacks mount in two different locations on bracket depending on tire size of chassis.
 - a) 19.5 Tires: Top hole in jack to top hole in bracket. Use 4 bolts in welded area of bracket.
 - b) 22.5 Tires: Top hole in jack to second hole in bracket. Use 6 bolts, 4 in welded area of bracket & 2 below welded area.

Item, Length	Description / Location	Qty	Color	Vendor PN	
Kit	(Items listed below)	1		8309	
Pump	7-Function, 3 Rooms & Jacks	1		7301BR	
Jack	12,000 lbs, 16" Stroke	4		7214	
Touch Pad	Located to the left of the drivers seat	1		2318	
Control Box	Attached to bottom of structure	1		2730	
Sync Cylinder	Mounted behind pump compartment	N/A		N/A	
Hose, 120	Pump to Jack, Left Front	2	Brown	2465	
Hose, 240	Pump to Jack, Left Rear	2	Orange	2475	
Hose, 168	Pump to Jack, Right Front	2	White	2469	
Hose, 252	Pump to Jack, Right Rear	1	Yellow	2587	
Hose,96	Left Rear Jack,Right Rear Jack	1	Yel/Ora.	2463	
Hose, 36	Pump to Room 1	2	Green	2458	127 / Drivers Side
Slide Unit	Room 1-36" Above floor slide	1		7164	
Hose, 372	Pump to Room 2	2	Purple	2481	319 / Drivers Side
Slide Unit	Room 2-30" Bed slide(Lippert)	1		134998	
Hose w/90, 372	Pump to Room 3	2	Gray	2481	319 / Passenger Side
Slide Unit	Room 3-18" Above floor slide	1		7135	
Hose, N/A	Pump to Room 4	N/A	Red	N/A	N/A
Travel Clamp	Two per Slide	2		HWH	N/A

Measuring from inside of firewall, this is the end location of the hydraulic hoses where they attach to the slide mechanism.

Options

Revisions

1	New chart for Windsport for MY2007 due to Faux Flat on Rm 1, starting with the schedule released 04/24/06.
2	Update per Equalizer Specs

**36F WINDSPORT/MAGELLAN (22.5) TIRES
EQUALIZER JACKS (FULLY AUTOMATIC)
STANDARD ON THIS UNIT**

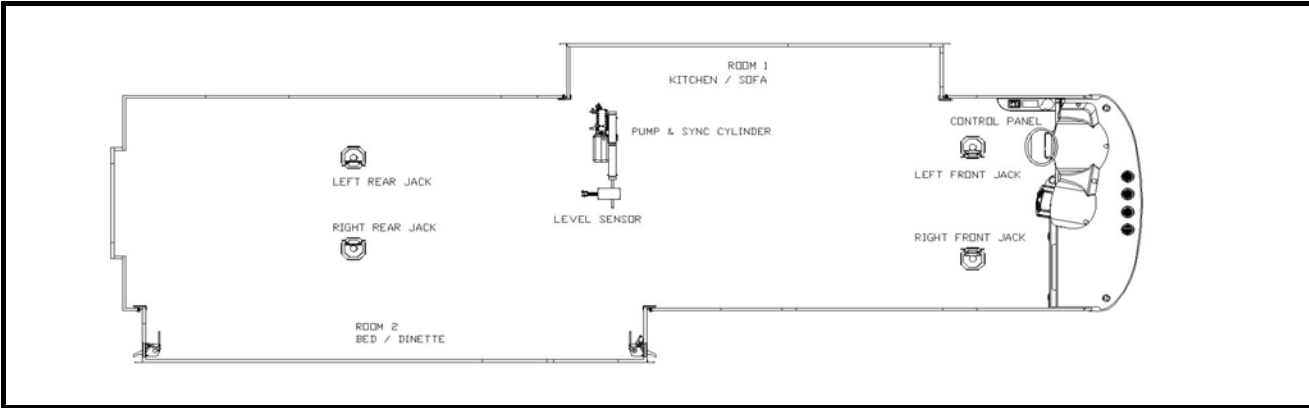

Notes:

- 1) Jacks mount in two different locations on bracket depending on tire size of chassis.
 - a) 19.5 Tires: Top hole in jack to top hole in bracket. Use 4 bolts in welded area of bracket.
 - b) 22.5 Tires: Top hole in jack to second hole in bracket. Use 6 bolts, 4 in welded area of bracket & 2 below welded area.
 - c) Hydraulic hose terminations for both rooms require 90 degree swivel elbows.

Item, Length	Description / Location	Qty	Color	Vendor PN	
Kit	(Items listed below)	1		8366	
Pump	6-Function, 2 Rooms & Jacks	1		7243BR	
Jack	12,000 lbs, 16" Stroke	4		7214	
Touch Pad	Located to the left of the drivers seat	1		2318	
Level Controller	Attached to bottom of structure	1		2730	
Sync Cylinder	Mounted inside pump compartment	1		7397	
Hose, 228	Pump to Jack, Left Front	2	Brown	2474	
Hose, 168	Pump to Jack, Left Rear	2	Orange	2469	
Hose, 264	Pump to Jack, Right Front	1	White	2476	
Hose, 204	Pump to Jack, Right Rear	1	Yellow	2472	
Hose, 96	Left Front Jack, Right Front Jack	1	Whi/Brn	2463	
Hose, 96	Left Front Jack, Right Rear Jack	1	Yel/Ora.	2463	
Hose w/90, 120	Pump to Room 1	2	Green	2465	135 / Drivers Side
Slide Unit	Room 1 - 24" above floor slide	1		7369	
Hose, 36	Pump to sync cylinder	2	Purple	2458	Inside pump compartment
Hose w/90, 240	Sync cylinder to front slide, Room 2	2	Purple	2475	225 / Passenger Side
Hose w/90, 240	Sync cylinder to rear slide, Room 2	2	Purple	2475	371 / Passenger Side
Slide Unit	Room 2 - 24" flush floor slide (angled)	2		7388	
Hose, N/A	Pump to Room 3	N/A	Gray	N/A	N/A
Hose, N/A	Pump to Room 4	N/A	Red	N/A	N/A
Travel Clamp	Two per Slide	2		HWH	N/A

Measuring from inside of firewall, this is the end location of the hydraulic hoses where they attach to the slide mechanism.

Options

Revisions

1	Update per Equalizer Specs
2	Add Magellan to usage in header per ECN 4582

**36R WINDSPORT/MAGELLAN (22.5) TIRES
EQUALIZER JACKS (FULLY AUTOMATIC)
STANDARD ON THIS UNIT**

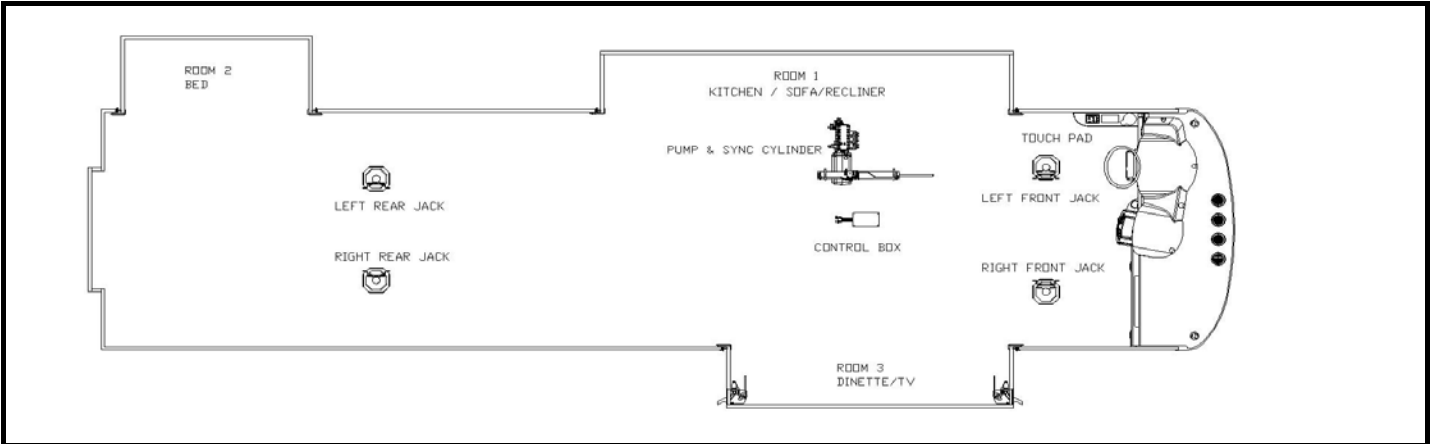

Notes:

- 1) Jacks mount in two different locations on bracket depending on tire size of chassis.
 - a) 19.5 Tires: Top hole in jack to top hole in bracket. Use 4 bolts in welded area of bracket.
 - b) 22.5 Tires: Top hole in jack to second hole in bracket. Use 6 bolts, 4 in welded area of bracket & 2 below welded area.
 - c) Hydraulic hose terminations for room #3 require 90 degree swivel elbows.

Item, Length	Description / Location	Qty	Color	Vendor PN	
Kit	(Items listed below)	1		8342	
Pump	7-Function, 3 Rooms & Jacks	1		7301BR	
Jack	12,000 lbs, 16" Stroke	4		7214	
Touch Pad	Located to the left of the drivers seat	1		2318	
Control Box	Attached to bottom of structure	1		2730	
Sync Cylinder	Mounted behind pump compartment	1		7397	
Hose, 120	Pump to Jack, Left Front	2	Brown	2465	
Hose, 240	Pump to Jack, Left Rear	2	Orange	2475	
Hose, 168	Pump to Jack, Right Front	2	White	2469	
Hose, 240	Pump to Jack, Right Rear	1	Yellow	2475	
Hose, 96	Left Rear Jack, Right Rear Jack	1	Yel/Ora.	2463	
Hose, 36	Pump to Room 1	2	Green	2458	127 / Drivers Side
Slide Unit	Room 1- 24" Above Floor slide	1		7369	
Hose, 420	Pump to Room 2	2	Purple	2485	335 / Drivers Side
Slide Unit	Room 2-30" bed slide(Lippert)	1		134998	
Hose, 36	Pump to sync cylinder	2	Gray	2458	Inside pump compartment
Hose, 120	Sync cylinder to front slide, Room 3	2	Gray	2465	90 / Passenger Side
Hose, 120	Sync cylinder to rear slide, Room 3	2	Gray	2465	145 / Passenger Side
Slide Unit	Room 3-24" Flush Floor slide	2		7388	
Hose, N/A	Pump to Room 4	N/A	Red	N/A	N/A
Travel Clamp	Two per Slide	2		HWH	N/A

Measuring from inside of firewall, this is the end location of the hydraulic hoses where they attach to the slide mechanism.

Options

Revisions

1	Update per Equalizer Specs
2	Add Magellan to usage in header per ECN 4582

**36Z WINDSPORT/MAGELLAN (22.5) TIRES
EQUALIZER JACKS (FULLY AUTOMATIC)
STANDARD ON THIS UNIT**

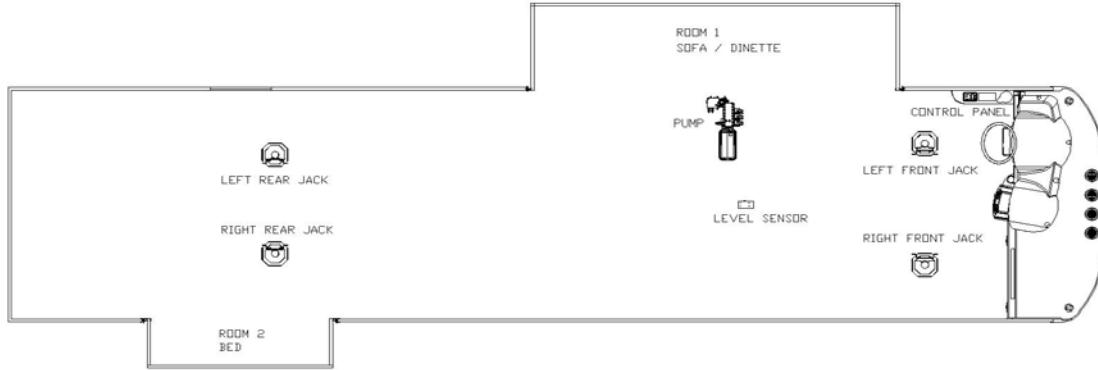

Notes:

1) Jacks mount in two different locations on bracket depending on tire size of chassis.

a) 19.5 Tires: Top hole in jack to top hole in bracket. Use 4 bolts in welded area of bracket.

b) 22.5 Tires: Top hole in jack to second hole in bracket. Use 6 bolts, 4 in welded area of bracket & 2 below welded area.

Item, Length	Description / Location	Qty	Color	Vendor PN	
Kit	(Items listed below)	1		8307	
Pump	6-Function, 2 Rooms & Jacks	1		7243BR	
Jack	12,000 lbs, 16" Stroke	4		7214	
Touch Pad	Located to the left of the drivers seat	1		2318	
Control Box	Attached to bottom of structure	1		2730	
Sync Cylinder	Mounted behind pump compartment	N/A		N/A	
Hose, 120	Pump to Jack, Left Front	2	Brown	2465	
Hose, 228	Pump to Jack, Left Rear	2	Orange	2474	
Hose, 156	Pump to Jack, Right Front	2	White	2468	
Hose, 252	Pump to Jack, Right Rear	1	Yellow	2587	
Hose, 108	Left Rear Jack, Right Rear Jack	1	Yel/Ora	2464	
Hose, 36	Pump to Room 1	2	Green	2458	127 / Drivers Side
Slide Unit	Room 1-36" Above floor slide	1		7164	
Hose, 372	Pump to Room 2	2	Purple	2481	319 / Passenger Side
Slide Unit	Room 2-30" Bed slide(Lippert)	1		134998	
Hose, N/A	Pump to Room 3	N/A	Gray	N/A	N/A
Hose, N/A	Pump to Room 4	N/A	Red	N/A	N/A
Hose, N/A	Pump to Generator Slide	N/A		N/A	N/A
Travel Clamp	Two per Slide	N/A		HWH	N/A

Measuring from inside of firewall, this is the end location of the hydraulic hoses where they attach to the slide mechanism.

Options

Revisions

1	New chart for Windsport for MY2007 due to Faux Flat on Rm 1, starting with the schedule released 04/24/06.
2	Update per Equalizer Specs
3	Add Magellan to usage in header per ECN 4582

**30Q WINDSPORT (19.5) TIRES
EQUALIZER JACKS (FULLY AUTOMATIC)
OPTIONAL ON THIS UNIT**



Notes:

1) Jacks mount in two different locations on bracket depending on tire size of chassis.

a) 19.5 Tires: Top hole in jack to top hole in bracket. Use 4 bolts in welded area of bracket.

b) 22.5 Tires: Top hole in jack to second hole in bracket. Use 6 bolts, 4 in welded area of bracket & 2 below welded area.

Item, Length	Description / Location	Qty	Color	Vendor PN	
Kit	(Items listed below)	1		8252	Measuring from inside of firewall, this is the end location of the hydraulic hoses where they attach to the slide mechanism.
Pump	4-Function, Jacks	1		7239BR	
Jack	12,000 lbs, 16" Stroke	4		7214	
Touch Pad	Located to the left of the drivers seat	1		2318	
Control Box	Attached to bottom of structure	1		2730	
Sync Cylinder	Mounted behind pump compartment	N/A		N/A	
Hose, 132	Pump to Jack, Left Front	2	Brown	2466	
Hose, 216	Pump to Jack, Left Rear	2	Orange	2473	
Hose, 180	Pump to Jack, Right Front	1	White	2470	
Hose, 264	Pump to Jack, Right Rear	1	Yellow	2476	
Hose, 96	Left Front Jack, Right Front Jack	1	Whi/Brn.	2463	
Hose, 96	Left Rear Jack, Right Rear Jack	1	Yel/Ora.	2463	
Hose, N/A	Pump to sync cylinder	N/A		N/A	
Hose, N/A	Sync cylinder to front slide, Room 1	N/A		N/A	
Hose, N/A	Sync cylinder to rear slide, Room 1	N/A		N/A	
Hose, N/A	Pump to Room 1	N/A		N/A	
Hose, N/A	Pump to Room 2	N/A		N/A	
Hose, N/A	Pump to Room 3	N/A		N/A	
Hose, N/A	Pump to Room 4	N/A		N/A	
Hose, N/A	Pump to Generator Slide	N/A		N/A	
Travel Clamp	Two per Slide	N/A		N/A	
Options					
Revisions					
1	New chart for Windsport for MY2007 due to Faux Flat on Rm 1, starting with the schedule released 04/24/06.				
2	Update per Equalizer Specs				

**31D WINDSPORT (19.5) TIRES
EQUALIZER JACKS (FULLY AUTOMATIC)
OPTIONAL ON THIS UNIT**

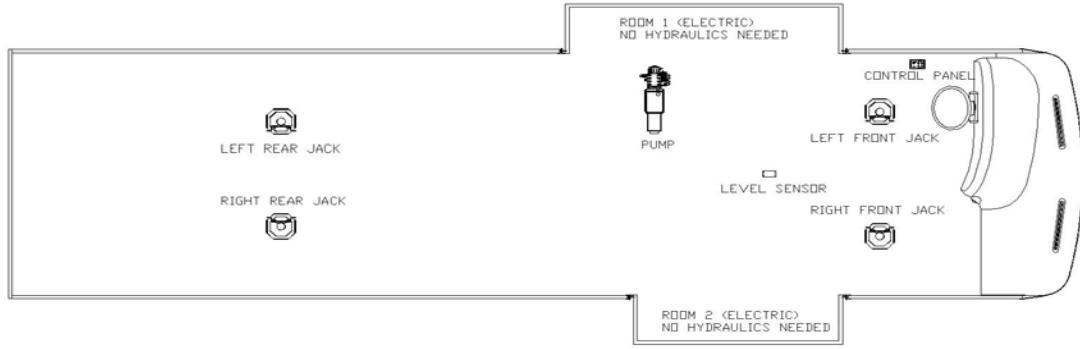

Notes:

- 1) Jacks mount in two different locations on bracket depending on tire size of chassis.
 - a) 19.5 Tires: Top hole in jack to top hole in bracket. Use 4 bolts in welded area of bracket.
 - b) 22.5 Tires: Top hole in jack to second hole in bracket. Use 6 bolts, 4 in welded area of bracket & 2 below welded area.

Item, Length	Description / Location	Qty	Color	Vendor PN	
Kit	(Items listed below)	1		8252	Measuring from inside of firewall, this is the end location of the hydraulic hoses where they attach to the slide mechanism.
Pump	4-Function, Jacks	1		7239BR	
Jack	12,000 lbs, 16" Stroke	4		7214	
Touch Pad	Located to the left of the drivers seat	1		2318	
Control Box	Attached to bottom of structure	1		2730	
Sync Cylinder	Mounted behind pump compartment	N/A		N/A	
Hose, 132	Pump to Jack, Left Front	2	Brown	2466	
Hose, 216	Pump to Jack, Left Rear	2	Orange	2473	
Hose, 180	Pump to Jack, Right Front	1	White	2470	
Hose, 264	Pump to Jack, Right Rear	1	Yellow	2476	
Hose, 96	Left Front Jack, Right Front Jack	1	Whi/Brn.	2463	
Hose, 96	Left Rear Jack, Right Rear Jack	1	Yel/Ora.	2463	
Hose, N/A	Pump to sync cylinder	N/A		N/A	
Hose, N/A	Sync cylinder to front slide, Room 1	N/A		N/A	
Hose, N/A	Sync cylinder to rear slide, Room 1	N/A		N/A	
Hose, N/A	Pump to Room 1	N/A		N/A	
Hose, N/A	Pump to Room 2	N/A		N/A	
Hose, N/A	Pump to Room 3	N/A		N/A	
Hose, N/A	Pump to Room 4	N/A		N/A	
Hose, N/A	Pump to Generator Slide	N/A		N/A	
Travel Clamp	Two per Slide	N/A		N/A	
Options					
Revisions					
1	New chart for Windsport for MY2007 due to Faux Flat on Rm 1, starting with the schedule released 04/24/06.				
2	Update per Equalizer Specs				

**32E WINDSPORT (19.5) TIRES
EQUALIZER JACKS (FULLY AUTOMATIC)
OPTIONAL ON THIS UNIT**

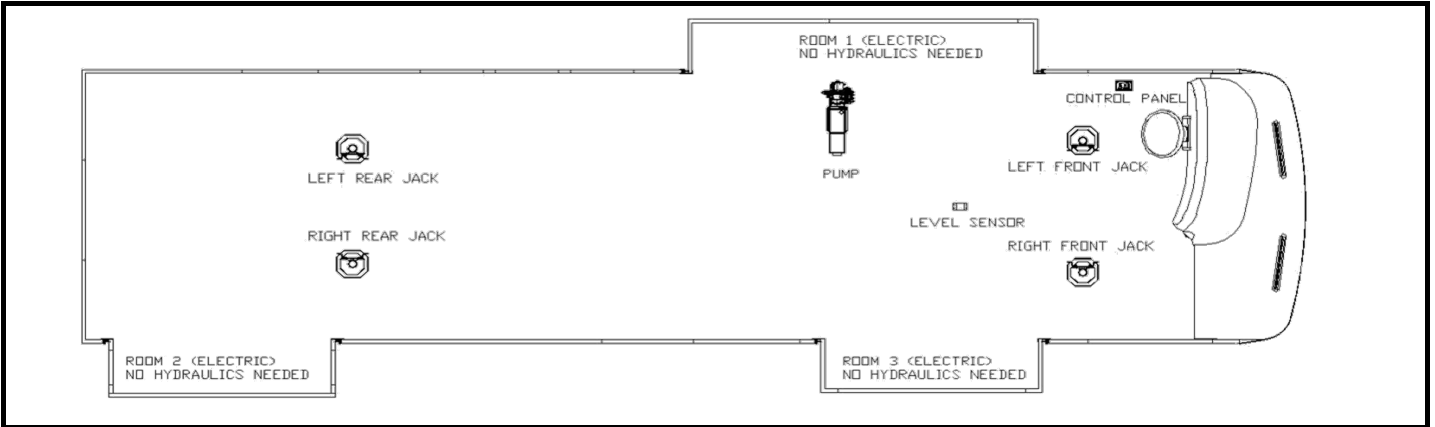

Notes:

- 1) Jacks mount in two different locations on bracket depending on tire size of chassis.
 - a) 19.5 Tires: Top hole in jack to top hole in bracket. Use 4 bolts in welded area of bracket.
 - b) 22.5 Tires: Top hole in jack to second hole in bracket. Use 6 bolts, 4 in welded area of bracket & 2 below welded area.

Item, Length	Description / Location	Qty	Color	Vendor PN	
Kit	(Items listed below)	1		8252	<p align="center">Measuring from inside of firewall, this is the end location of the hydraulic hoses where they attach to the slide mechanism.</p>
Pump	4-Function, Jacks	1		7239BR	
Jack	12,000 lbs, 16" Stroke	4		7214	
Touch Pad	Located to the left of the drivers seat	1		2318	
Control Box	Attached to bottom of structure	1		2730	
Sync Cylinder	Mounted behind pump compartment	N/A		N/A	
Hose, 132	Pump to Jack, Left Front	2	Brown	2466	
Hose, 216	Pump to Jack, Left Rear	2	Orange	2473	
Hose, 180	Pump to Jack, Right Front	1	White	2470	
Hose, 264	Pump to Jack, Right Rear	1	Yellow	2476	
Hose, 96	Left Front Jack, Right Front Jack	1	Whi/Brn.	2463	
Hose, 96	Left Rear Jack, Right Rear Jack	1	Yel/Ora.	2463	
Hose, N/A	Pump to sync cylinder	N/A		N/A	
Hose, N/A	Sync cylinder to front slide, Room 1	N/A		N/A	
Hose, N/A	Sync cylinder to rear slide, Room 1	N/A		N/A	
Hose, N/A	Pump to Room 1	N/A		N/A	
Hose, N/A	Pump to Room 2	N/A		N/A	
Hose, N/A	Pump to Room 3	N/A		N/A	
Hose, N/A	Pump to Room 4	N/A		N/A	
Hose, N/A	Pump to Generator Slide	N/A		N/A	
Travel Clamp	Two per Slide	N/A		N/A	
Options					
Revisions					
1	New chart for Windsport for MY2007 due to Faux Flat on Rm 1, starting with the schedule released 04/24/06.				
2	Update per Equalizer Specs				

**33T WINDSPORT (19.5) TIRES
EQUALIZER JACKS (FULLY AUTOMATIC)
OPTIONAL ON THIS UNIT**

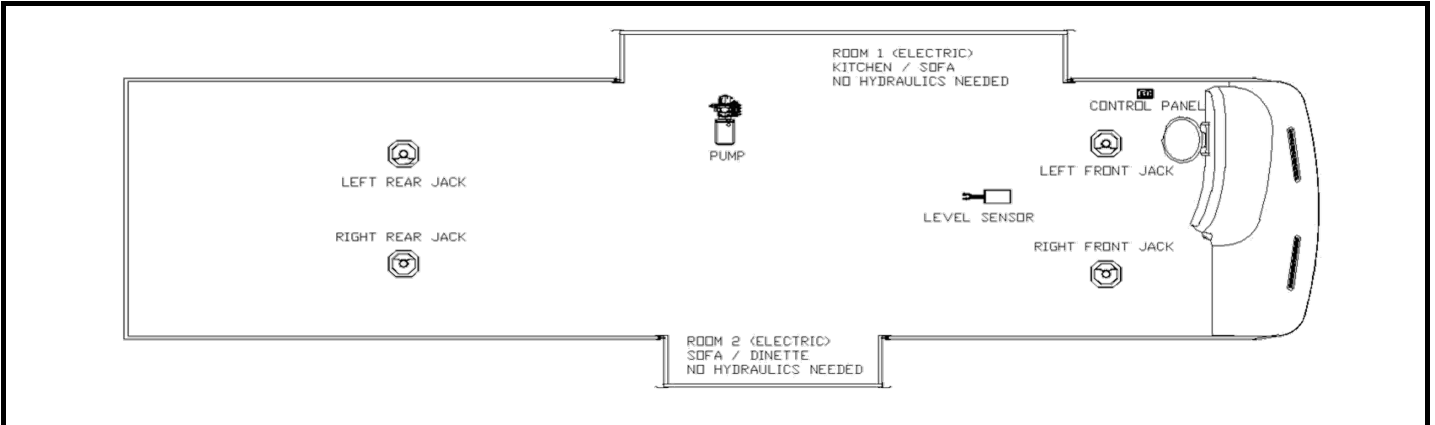

Notes:

- 1) Jacks mount in two different locations on bracket depending on tire size of chassis.
 - a) 19.5 Tires: Top hole in jack to top hole in bracket. Use 4 bolts in welded area of bracket.
 - b) 22.5 Tires: Top hole in jack to second hole in bracket. Use 6 bolts, 4 in welded area of bracket & 2 below welded area.

Item, Length	Description / Location	Qty	Color	Vendor PN	
Kit	(Items listed below)	1		8381	Measuring from inside of firewall, this is the end location of the hydraulic hoses where they attach to the slide mechanism.
Pump	4-Function, Jacks	1		7239BR	
Jack	12,000 lbs, 16" Stroke	4		7214	
Touch Pad	Located to the left of the drivers seat	1		2318	
Control Box	Attached to bottom of structure	1		2730	
Flow Divider	Mounted behind pump compartment	N/A		N/A	
Hose, 204	Pump to Jack, Left Front	2	Brown	2472	
Hose, 180	Pump to Jack, Left Rear	2	Orange	2470	
Hose, 252	Pump to Jack, Right Front	1	White	2587	
Hose, 216	Pump to Jack, Right Rear	1	Yellow	2473	
Hose, 96	Left Front Jack, Right Front Jack	1	Whi/Brn.	2463	
Hose, 96	Left Rear Jack, Right Rear Jack	1	Yel/Ora.	2463	
Hose, N/A	Pump to Flow Divider	N/A	N/A	N/A	
Hose, N/A	Flow divider to front slide, Room 1	N/A	N/A	N/A	N/A
Hose, N/A	Flow divider to rear slide, Room 1	N/A	N/A	N/A	N/A
Hose, N/A	Pump to Room 1	N/A	Green	N/A	N/A
Hose, N/A	Pump to Room 2	N/A	Purple	N/A	N/A
Hose, N/A	Pump to Room 3	N/A	Gray	N/A	N/A
Hose, N/A	Pump to Room 4	N/A	Red	N/A	N/A
Hose, N/A	Pump to Generator Slide	N/A	TBD	N/A	N/A
Travel Clamp	Two per Slide	N/A		HWH	N/A
Options					

Revisions	
1	New chart for Windsport for MY2007 due to Faux Flat on Rm 1, starting with the schedule released 04/24/06.
2	Update per Equalizer Specs

**32R WINDSPORT (22.5) TIRES
EQUALIZER JACKS (FULLY AUTOMATIC)
STANDARD ON THIS UNIT**

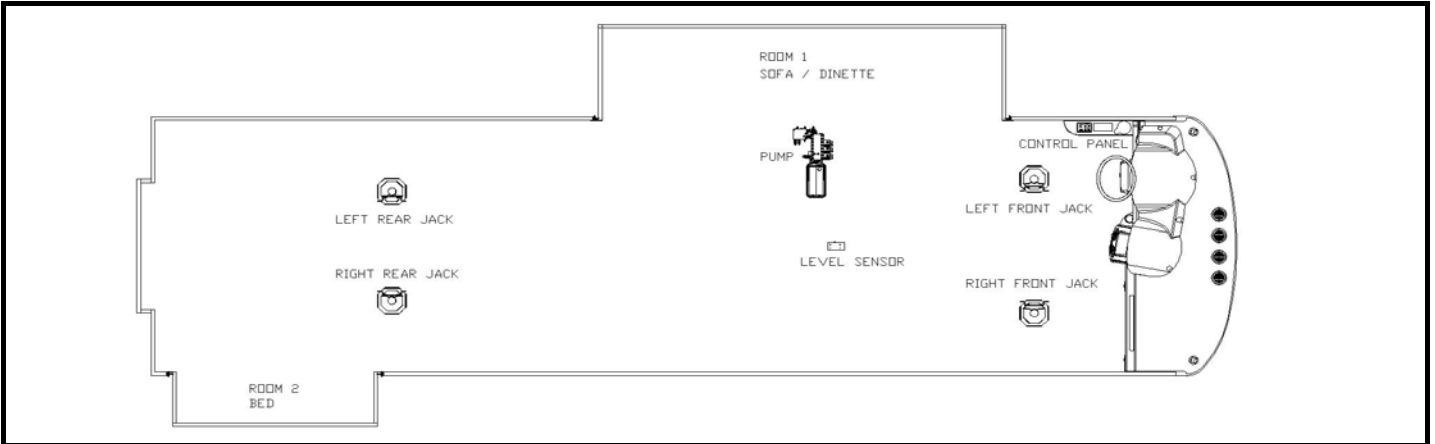

Notes:

1) Jacks mount in two different locations on bracket depending on tire size of chassis.

a) 19.5 Tires: Top hole in jack to top hole in bracket. Use 4 bolts in welded area of bracket.

b) 22.5 Tires: Top hole in jack to second hole in bracket. Use 6 bolts, 4 in welded area of bracket & 2 below welded area.

Item, Length	Description / Location	Qty	Color	Vendor PN	
Kit	(Items listed below)	1		8308	Measuring from inside of firewall, this is the end location of the hydraulic hoses where they attach to the slide mechanism.
Pump	6-Function, 2 Rooms & Jacks	1		7243BR	
Jack	12,000 lbs, 16" Stroke	4		7214	
Touch Pad	Located to the left of the drivers seat	1		2318	
Control Box	Attached to bottom of structure	1		2730	
Sync Cylinder	Mounted behind pump compartment	N/A		N/A	
Hose, 144	Pump to Jack, Left Front	2	Brown	2467	
Hose, 240	Pump to Jack, Left Rear	2	Orange	2475	
Hose, 180	Pump to Jack, Right Front	1	White	2470	
Hose, 288	Pump to Jack, Right Rear	1	Yellow	2478	
Hose, 96	Left Front Jack, Right Front Jack	1	Whi/Brn	2463	
Hose, 96	Left Rear Jack, Right Rear Jack	1	Yel/Ora.	2463	
Hose, N/A	Pump to sync cylinder	N/A	Green	N/A	Inside pump compartment
Hose, N/A	Sync cylinder to front slide, Room 1	N/A	Green	N/A	N/A
Hose, N/A	Sync cylinder to rear slide, Room 1	N/A	Green	N/A	N/A
Hose, 36	Pump to Room 1	2	Green	2458	127 / Drivers Side
Slide Unit	Room 1-36" Above floor slide	1		7164	
Hose, 372	Pump to Room 2	2	Purple	2481	310 / Passenger Side
Slide Unit	Room 2-30" Bed Slide (Lippert)	1		134998	
Hose, N/A	Pump to Room 3	N/A	Gray	N/A	N/A
Slide Unit					
Hose, N/A	Pump to Room 4	N/A	Red	N/A	N/A
Slide Unit					
Travel Clamp	Two per Slide	N/A		HWH	N/A

Options

Revisions

1	New chart for Windsport for MY2007 due to Faux Flat on Rm 1, starting with the schedule released 04/24/06.
2	Update per Equalizer Specs

**34B WINDSPORT/MAGELLAN (22.5) TIRES
EQUALIZER JACKS (FULLY AUTOMATIC)
STANDARD ON THIS UNIT**

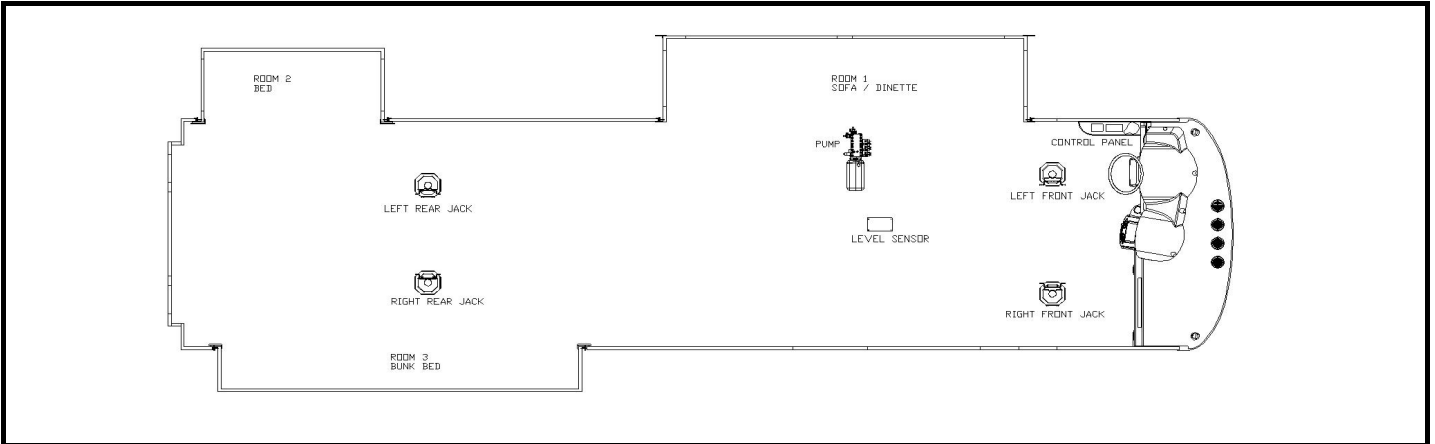

Notes:

1) Jacks mount in two different locations on bracket depending on tire size of chassis.

a) 19.5 Tires: Top hole in jack to top hole in bracket. Use 4 bolts in welded area of bracket.

b) 22.5 Tires: Top hole in jack to second hole in bracket. Use 6 bolts, 4 in welded area of bracket & 2 below welded area.

Item, Length	Description / Location	Qty	Color	Vendor PN	
Kit	(Items listed below)	1		8323	
Pump	7-Function, 3 Rooms & Jacks	1		7301BR	
Jack	12,000 lbs, 16" Stroke	4		7214	
Touch Pad	Located to the left of the drivers seat	1		2318	
Control Box	Attached to bottom of structure	1		2730	
Sync Cylinder	Mounted behind pump compartment	N/A		N/A	
Hose, 132	Pump to Jack, Left Front	2	Brown	2466	
Hose, 240	Pump to Jack, Left Rear	2	Orange	2475	
168	Pump to Jack, Right Front	2	White	2469	
Hose, 264	Pump to Jack, Right Rear	1	Yellow	2476	
Hose, 96	Left Rear Jack, Right Rear Jack	1	Yel/Ora	2463	
Hose, 36	Pump to Room 1	2	Green	2458	127 / Drivers Side
Slide Unit	Room 1-36" Above Floor Slide	1		7164	
Hose, 372	Pump to Room 2	2	Purple	2481	347 / Drivers Side
Slide Unit	Room 2-30" Bed Slide(Lipper)	1		134998	
Hose w90, 372	Pump to Room 3	2	Gray	2481	307 / Passenger Side
Slide Unit	Room 3-18" Above floor slide	1		7135	
Hose, N/A	Pump to Room 4	N/A	Red	N/A	N/A
Travel Clamp	Two per Slide	N/A		N/A	N/A

Measuring from inside of firewall, this is the end location of the hydraulic hoses where they attach to the slide mechanism.

Options

Revisions

1	Update per Equalizer Specs
2	Add Magellan to chart, same as Windsport per ECN 4582.

**34U WINDSPORT/MAGELLAN (22.5) TIRES
EQUALIZER JACKS (FULLY AUTOMATIC)
STANDARD ON THIS UNIT**

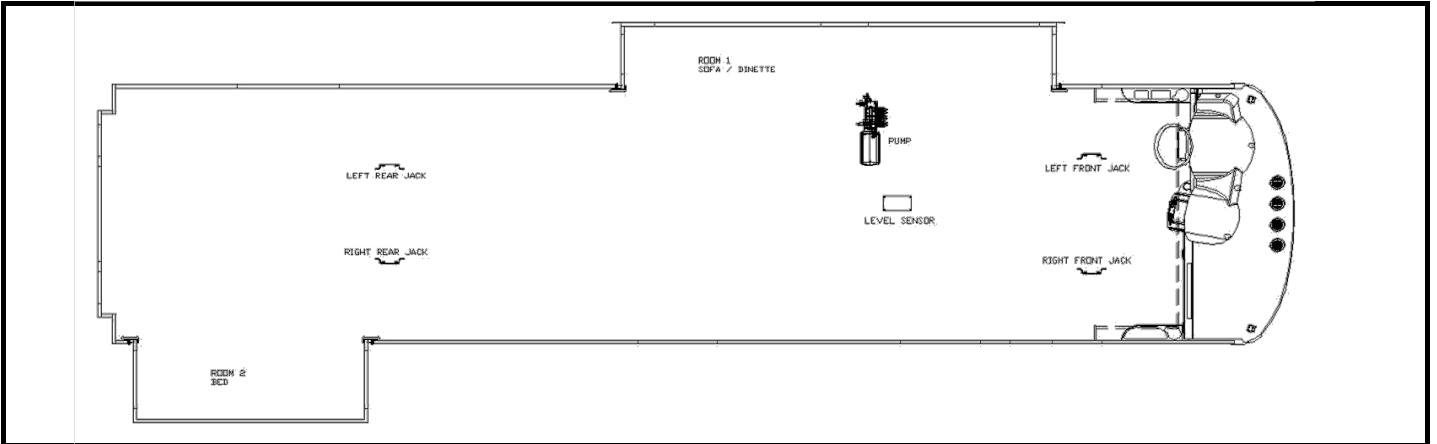

Notes:

- 1) Jacks mount in two different locations on bracket depending on tire size of chassis.
 - a) 19.5 Tires: Top hole in jack to top hole in bracket. Use 4 bolts in welded area of bracket.
 - b) 22.5 Tires: Top hole in jack to second hole in bracket. Use 6 bolts, 4 in welded area of bracket & 2 below welded area.

Item, Length	Description / Location	Qty	Color	Vendor PN		
Kit	(Items listed below)	1		8466	Measuring from inside of firewall, this is the end location of the hydraulic hoses where they attach to the slide mechanism.	
Pump	6-Function, 2 Rooms & Jacks	1		7243BR		
Jack	12,000 lbs, 16" Stroke	4		7214		
Touch Pad	Located to the left of the drivers seat	1		2318		
Control Box	Attached to bottom of structure	1		2730		
Sync Cylinder	Mounted behind pump compartment	N/A		N/A		
Hose, 132	Pump to Jack, Left Front	2	Brown	2466		
Hose, 240	Pump to Jack, Left Rear	2	Orange	2475		
Hose, 168	Pump to Jack, Right Front	2	White	2469		
Hose, 264	Pump to Jack, Right Rear	1	Yellow	2476		
Hose, 96	Left Rear Jack, Right Rear Jack	1	Yel/Ora.	2463		Inside pump compartment
Hose, 36	Pump to Room 1	2	Green	2458		127 / Drivers Side
Slide Unit	Room 1-36" Above Floor Slide	1		7164		N/A
Hose, 372	Pump to Room 2	2	Purple	2481	347 / Passenger Side	
Slide Unit	Room 2-30" Bed Slide(Lipper)	1		134998		
Hose, N/A	Pump to Room 3		Gray			
Slide Unit	Room 3-				N/A	
Hose, N/A	Pump to Room 4	N/A	Red	N/A	N/A	
Travel Clamp	Two per Slide	N/A		N/A	N/A	

Options

Revisions

**34Y WINDSPORT (19.5) TIRES
EQUALIZER JACKS (FULLY AUTOMATIC)
STANDARD ON THIS UNIT**

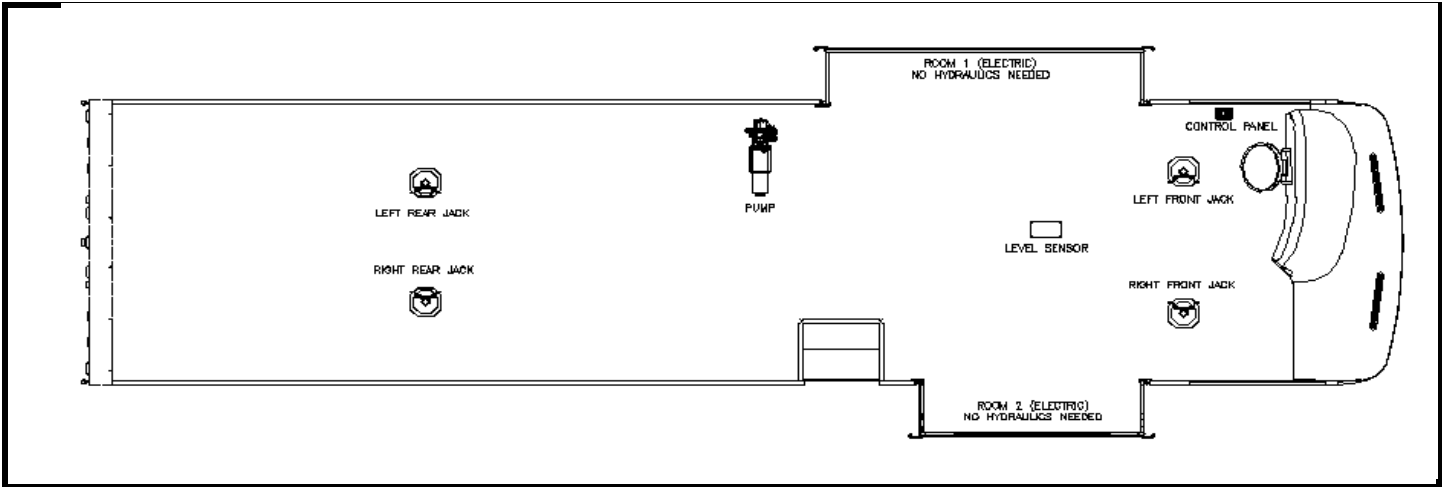

Notes:

1) Jacks mount 2nd hole from top to top mounting plate hole.

Item, Length	Description / Location	Qty	Color	Vendor PN		
Kit	(Items listed below)	1		8365	Measuring from back of cab floor, this is the end location of the hydraulic hoses where they attach to the slide mechanism.	
Pump	4-Function, Jacks Only	1		7239BR		
Jack	12,000 lbs, 16" Stroke	4		7214		
Touch Pad	Located to the left of the drivers seat	1		2318		
Control Box	Attached to bottom of structure	1		2730		
Sync Cylinder	Mounted behind pump compartment	N/A		N/A		
Hose, 180	Pump to Jack, Left Front	2	Brown	2470		
Hose, 180	Pump to Jack, Left Rear	2	Orange	2470		
Hose, 216	Pump to Jack, Right Front	1	White	2473		
Hose, 180	Pump to Jack, Right Rear	1	Yellow	2470		
Hose, 96	Left Front Jack, Right Front Jack	1	Whi/Brn.	2463		
Hose, 96	Left Rear Jack, Right Rear Jack	1	Yel/Ora.	2463		
Hose, N/A	Pump to Flow Divider	N/A	N/A	N/A		N/A
Hose, N/A	Flow divider to front slide, Room 1	N/A	N/A	N/A		N/A
Hose, N/A	Flow divider to rear slide, Room 1	N/A	N/A	N/A		N/A
Hose, N/A	Pump to Room 1	N/A	Green	N/A		N/A
Hose, N/A	Pump to Room 2	N/A	Purple	N/A		N/A
Hose, N/A	Pump to Room 3	N/A	Gray	N/A		N/A
Hose, N/A	Pump to Room 4	N/A	Red	N/A		N/A
Hose, N/A	Pump to Generator Slide	N/A	TBD	N/A	N/A	
Travel Clamp	Two per Slide	N/A		HWH	N/A	
Options						

Revisions

1	Update per Equalizer Specs			

**36E WINDSPORT/MAGELLAN (22.5) TIRES
EQUALIZER JACKS (FULLY AUTOMATIC)
STANDARD ON THIS UNIT**

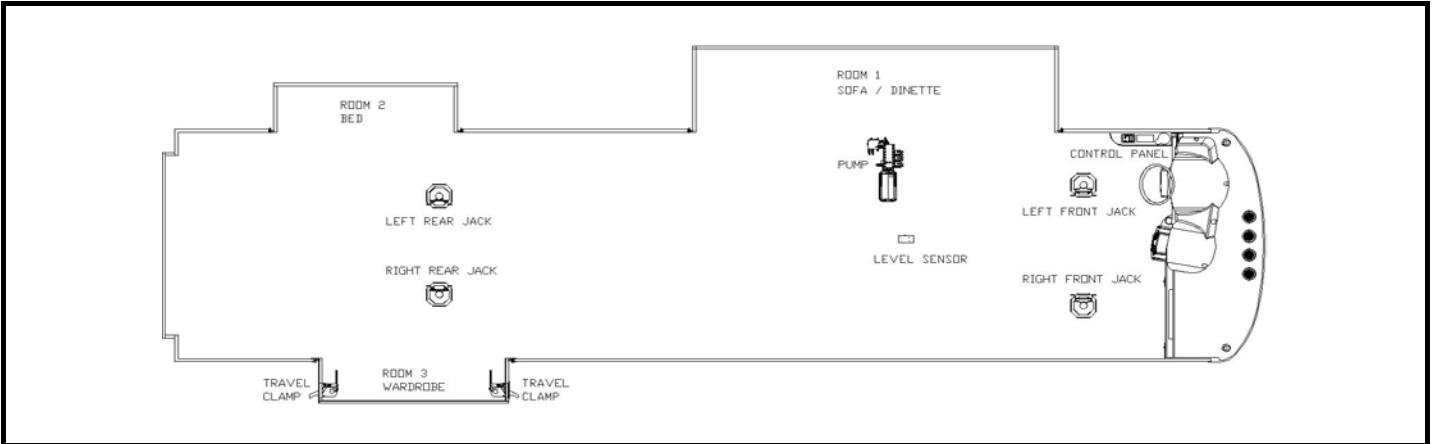

Notes:

- 1) Jacks mount in two different locations on bracket depending on tire size of chassis.
 - a) 19.5 Tires: Top hole in jack to top hole in bracket. Use 4 bolts in welded area of bracket.
 - b) 22.5 Tires: Top hole in jack to second hole in bracket. Use 6 bolts, 4 in welded area of bracket & 2 below welded area.

Item, Length	Description / Location	Qty	Color	Vendor PN		
Kit	(Items listed below)	1		8309	Measuring from inside of firewall, this is the end location of the hydraulic hoses where they attach to the slide mechanism.	
Pump	7-Function, 3 Rooms & Jacks	1		7301BR		
Jack	12,000 lbs, 16" Stroke	4		7214		
Touch Pad	Located to the left of the drivers seat	1		2318		
Control Box	Attached to bottom of structure	1		2730		
Sync Cylinder	Mounted behind pump compartment	N/A		N/A		
Hose, 120	Pump to Jack, Left Front	2	Brown	2465		
Hose, 240	Pump to Jack, Left Rear	2	Orange	2475		
Hose, 168	Pump to Jack, Right Front	2	White	2469		
Hose, 252	Pump to Jack, Right Rear	1	Yellow	2587		
Hose,96	Left Rear Jack, Right Rear Jack	1	Yel/Ora.	2463		
Hose, 36	Pump to Room 1	2	Green	2458		127 / Drivers Side
Slide Unit	Room 1-36" Above floor slide	1		7164		
Hose, 372	Pump to Room 2	2	Purple	2481		319 / Drivers Side
Slide Unit	Room 2-30" Bed slide(Lippert)	1		134998		
Hose w/90, 372	Pump to Room 3	2	Gray	2481	319 / Passenger Side	
Slide Unit	Room 3-18" Above floor slide	1		7135		
Hose, N/A	Pump to Room 4	N/A	Red	N/A	N/A	
Travel Clamp	Two per Slide	2		HWH	N/A	

Options

Revisions

1	New chart for Windsport for MY2007 due to Faux Flat on Rm 1, starting with the schedule released 04/24/06.
2	Update per Equalizer Specs

**36R WINDSPORT/MAGELLAN (22.5) TIRES
EQUALIZER JACKS (FULLY AUTOMATIC)
STANDARD ON THIS UNIT**

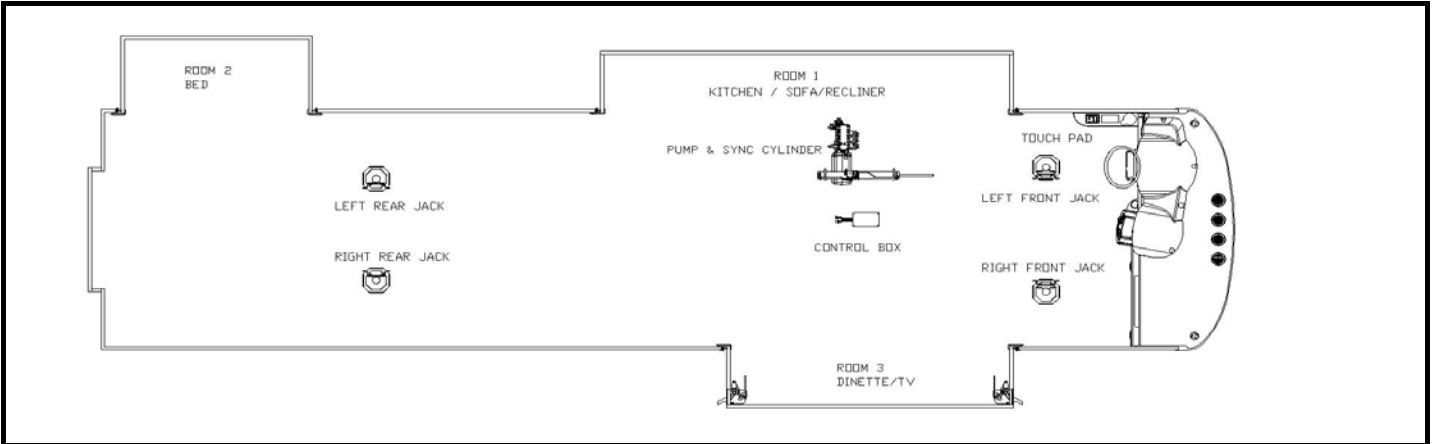

Notes:

- 1) Jacks mount in two different locations on bracket depending on tire size of chassis.
 - a) 19.5 Tires: Top hole in jack to top hole in bracket. Use 4 bolts in welded area of bracket.
 - b) 22.5 Tires: Top hole in jack to second hole in bracket. Use 6 bolts, 4 in welded area of bracket & 2 below welded area.
 - c) Hydraulic hose terminations for room #3 require 90 degree swivel elbows.

Item, Length	Description / Location	Qty	Color	Vendor PN		
Kit	(Items listed below)	1		8342	Measuring from inside of firewall, this is the end location of the hydraulic hoses where they attach to the slide mechanism.	
Pump	7-Function, 3 Rooms & Jacks	1		7301BR		
Jack	12,000 lbs, 16" Stroke	4		7214		
Touch Pad	Located to the left of the drivers seat	1		2318		
Control Box	Attached to bottom of structure	1		2730		
Sync Cylinder	Mounted behind pump compartment	1		7397		
Hose, 120	Pump to Jack, Left Front	2	Brown	2465		
Hose, 240	Pump to Jack, Left Rear	2	Orange	2475		
Hose, 168	Pump to Jack, Right Front	2	White	2469		
Hose, 240	Pump to Jack, Right Rear	1	Yellow	2475		
Hose, 96	Left Rear Jack, Right Rear Jack	1	Yel/Ora.	2463		
Hose, 36	Pump to Room 1	2	Green	2458		127 / Drivers Side
Slide Unit	Room 1- 24" Above Floor slide	1		7369		
Hose, 420	Pump to Room 2	2	Purple	2485	335 / Drivers Side	
Slide Unit	Room 2-30" bed slide(Lippert)	1		134998		
Hose, 36	Pump to sync cylinder	2	Gray	2458	Inside pump compartment	
Hose, 120	Sync cylinder to front slide, Room 3	2	Gray	2465	90 / Passenger Side	
Hose, 120	Sync cylinder to rear slide, Room 3	2	Gray	2465	145 / Passenger Side	
Slide Unit	Room 3-24" Flush Floor slide	2		7388		
Hose, N/A	Pump to Room 4	N/A	Red	N/A	N/A	
Travel Clamp	Two per Slide	2		HWH	N/A	

Options

Item, Length	Description / Location	Qty	Color	Vendor PN	

Revisions

1	Update per Equalizer Specs
2	Add Magellan to usage in header per ECN 4582

**36Z WINDSPORT/MAGELLAN (22.5) TIRES
EQUALIZER JACKS (FULLY AUTOMATIC)
STANDARD ON THIS UNIT**

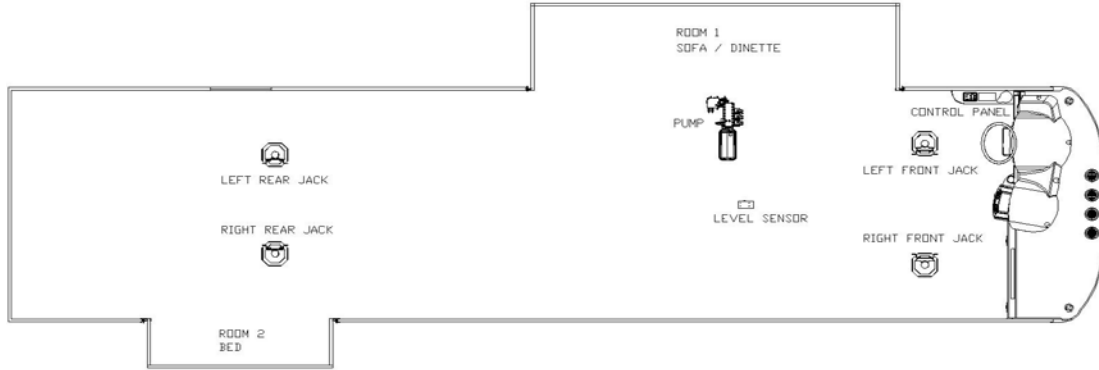

Notes:

1) Jacks mount in two different locations on bracket depending on tire size of chassis.

a) 19.5 Tires: Top hole in jack to top hole in bracket. Use 4 bolts in welded area of bracket.

b) 22.5 Tires: Top hole in jack to second hole in bracket. Use 6 bolts, 4 in welded area of bracket & 2 below welded area.

Item, Length	Description / Location	Qty	Color	Vendor PN	
Kit	(Items listed below)	1		8307	
Pump	6-Function, 2 Rooms & Jacks	1		7243BR	
Jack	12,000 lbs, 16" Stroke	4		7214	
Touch Pad	Located to the left of the drivers seat	1		2318	
Control Box	Attached to bottom of structure	1		2730	
Sync Cylinder	Mounted behind pump compartment	N/A		N/A	
Hose, 120	Pump to Jack, Left Front	2	Brown	2465	Measuring from inside of firewall, this is the end location of the hydraulic hoses where they attach to the slide mechanism.
Hose, 228	Pump to Jack, Left Rear	2	Orange	2474	
Hose, 156	Pump to Jack, Right Front	2	White	2468	
Hose, 252	Pump to Jack, Right Rear	1	Yellow	2587	
Hose, 108	Left Rear Jack, Right Rear Jack	1	Yel/Ora	2464	
Hose, 36	Pump to Room 1	2	Green	2458	127 / Drivers Side
Slide Unit	Room 1-36" Above floor slide	1		7164	
Hose, 372	Pump to Room 2	2	Purple	2481	319 / Passenger Side
Slide Unit	Room 2-30" Bed slide(Lippert)	1		134998	
Hose, N/A	Pump to Room 3	N/A	Gray	N/A	N/A
Hose, N/A	Pump to Room 4	N/A	Red	N/A	N/A
Hose, N/A	Pump to Generator Slide	N/A		N/A	N/A
Travel Clamp	Two per Slide	N/A		HWH	N/A

Options

Revisions

1	New chart for Windsport for MY2007 due to Faux Flat on Rm 1, starting with the schedule released 04/24/06.
2	Update per Equalizer Specs
3	Add Magellan to usage in header per ECN 4582

**38D Presidio
EQUALIZER JACKS (FULLY AUTOMATIC)
STANDARD ON THIS UNIT**

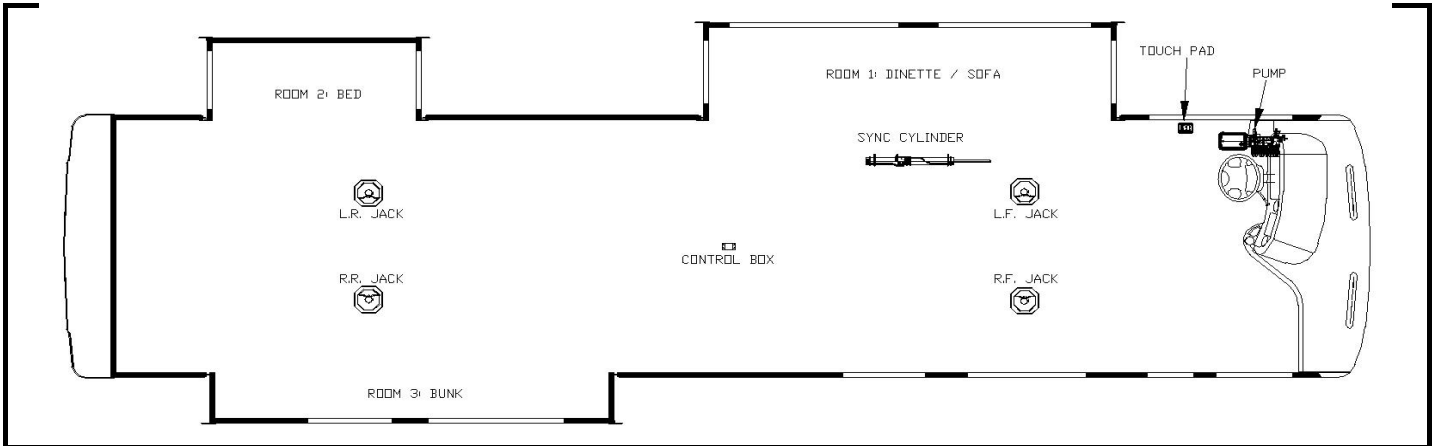

Notes:

- 1) Jacks mount to chassis brackets with the lowest holes of the jacks aligned with the lowest holes of the mounting brackets.
- 2) Level sensor attaches to bottom of structure; on lower hat section flanges or square tube.
- 3) Hydraulic hose terminations for room #1 & #3 require 90 degree swivel elbows.
- 4) Reference FM-3991 for a better visual of Room 1 hydraulic connections.
- 5) Hoses marked w90 will have the 90 deg fitting shipped loose.

Item, Length	Description / Location	Qty	Color	Vendor PN	
Kit	(Items listed below)	1		8347	
Pump	7-Function, 3 Rooms & Jacks	1		7319BR	
Jack	17,000 lbs, 18" Stroke	4		7134	
Touch Pad	Located to the left of the drivers seat	1		2318	
Control Box	Attached to bottom of structure	1		2730	
Sync Cylinder	Mounted behind LP tank	1		7387	
Hose, 132	Pump to Jack, Left Front	2	Brown	2466	
Hose, 384	Pump to Jack, Left Rear	2	Orange	2482	
Hose, 144	Pump to Jack, Right Front	2	White	2467	
Hose, 396	Pump to Jack, Right Rear	1	Yellow	2483	
Hose, 108	Left Rear Jack, Right Rear Jack	1	Yel/Ora.	2464	
Hose, 144	Pump to synchronizing manifold	2	Green	2467	Mounts to bracket on structure
Hose w90, 168	Sync cylinder to front slide, Room 1	2	Green	2469	196 / Drivers side
Hose w90, 168	Sync cylinder to rear slide, Room 1	2	Green	2469	196 / Drivers side
	Pump to Room 1	N/A	Green		
Slide Unit	Room 1 - 36" flush floor slide	2		7523	
Hose, 444	Pump to Room 2	2	Purple	2487	325 / Drivers Side
Slide Unit	Room 2 - 30" Bed slide (Lippert)	1		134998	
Hose w90, 468	Pump to Room 3	2	Gray	2489	355 / Passenger Side
Slide Unit	Room 3 - 18" above floor slide	1		7135	
	Pump to Generator Slide	N/A			
Travel Clamp	(two per slide, dinette / sofa slide only)	2		HWH	N/A

Measuring from inside of firewall, this is the end location of the hydraulic hoses where they attach to the slide mechanism.

Options

Revisions

1					

**40J Presidio
EQUALIZER JACKS (FULLY AUTOMATIC)
STANDARD ON THIS UNIT**

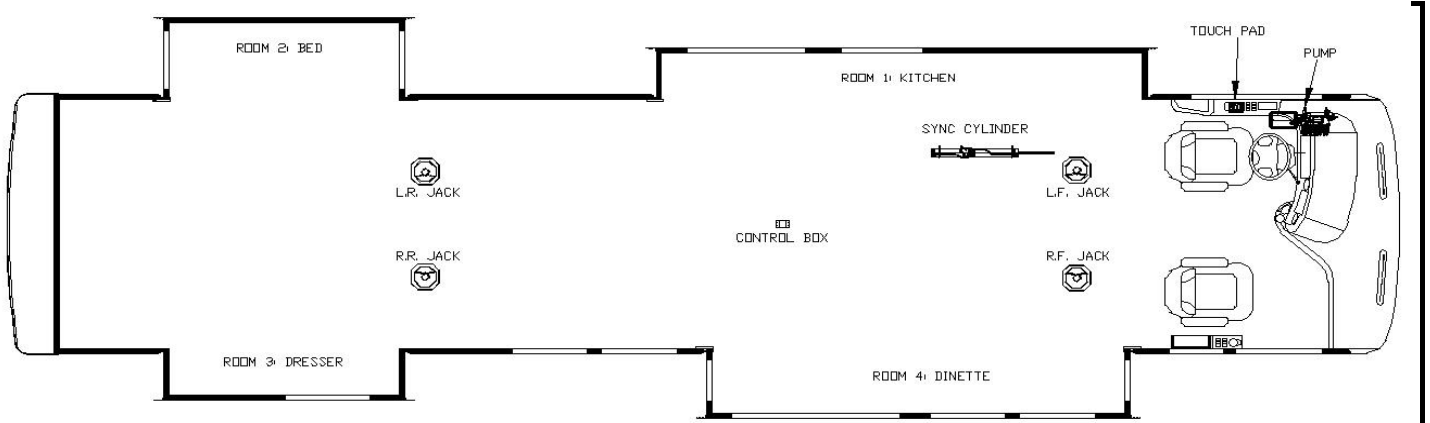

Notes:

- 1) Jacks mount to chassis brackets with the lowest holes of the jacks aligned with the lowest holes of the mounting brackets.
- 2) Level sensor attaches to bottom of structure; on the square tube the runs full length from axle to axle.
- 3) Hydraulic hose terminations for room #1, #3, & #4 require 90 degree swivel elbows.
- 4) Reference FM-3991 for a better visual of Room 4 hydraulic connections.
- 5) Hoses marked w90 will have the 90 deg fitting shipped loose.

Item, Length	Description / Location	Qty	Color	Vendor PN	
Kit	(Items listed below)	1		8421	
Pump	8-Function, 4 Rooms & Jacks	1		7302BR	
Jack	17,000 lbs, 18" Stroke	4		7134	
Touch Pad	Located to the left of the drivers seat	1		2318	
Control Box	Attached to bottom of structure	1		2730	
Sync Cylinder	Mounted behind LP tank	1		7397	
Sync Cylinder	Mounted behind LP tank	1		7511	
Hose, 144	Pump to Jack, Left Front	2	Brown	2467	
Hose, 408	Pump to Jack, Left Rear	2	Orange	2484	
Hose, 144	Pump to Jack, Right Front	2	White	2467	
Hose, 408	Pump to Jack, Right Rear	1	Yellow	2484	
Hose, 108	Left Rear Jack, Right Rear Jack	1	Yel/Ora.	2464	
Hose, 192	Pump to synchronizing cylinder	2	Green	2471	Mounts to bracket on structure
Hose w90, 144	Sync cylinder to front slide, Room 1	2	Green	2467	124 / Drivers side
Hose w90, 144	Sync cylinder to rear slide, Room 1	2	Green	2467	214 / Drivers side
Slide Unit	Room 1 - 18" above floor slide	2		7135	
Hose, 480	Pump to Room 2	2	Purple	2490	386 / Drivers Side
Slide Unit	Room 2 - 30" Bed slide (Lippert)	1		134998	
Hose w90, 480	Pump to Room 3	2	Gray	2490	365 / Passenger Side
Slide Unit	Room 3 - 18" above floor slide	1		7135	
Hose, 192	Pump to synchronizing cylinder	2	Red	2471	Mounts to bracket on structure
Hose w90, 144	Sync cylinder to front slide, Room 4	2	Red	2467	124 / Passenger side
Hose w90, 144	Sync cylinder to rear slide, Room 4	2	Red	2467	214 / Passenger side
Slide Unit	Room 4 - 24" flush floor slide	2		7388	
	Pump to Generator Slide	N/A			N/A
Travel Clamp	(two per slide, except the bed slide)	6		HWH	N/A
Options					
Revisions					
1					

Measuring from inside of firewall, this is the end location of the hydraulic hoses where they attach to the slide mechanism.

**42A Presidio
EQUALIZER JACKS (FULLY AUTOMATIC)
STANDARD ON THIS UNIT**

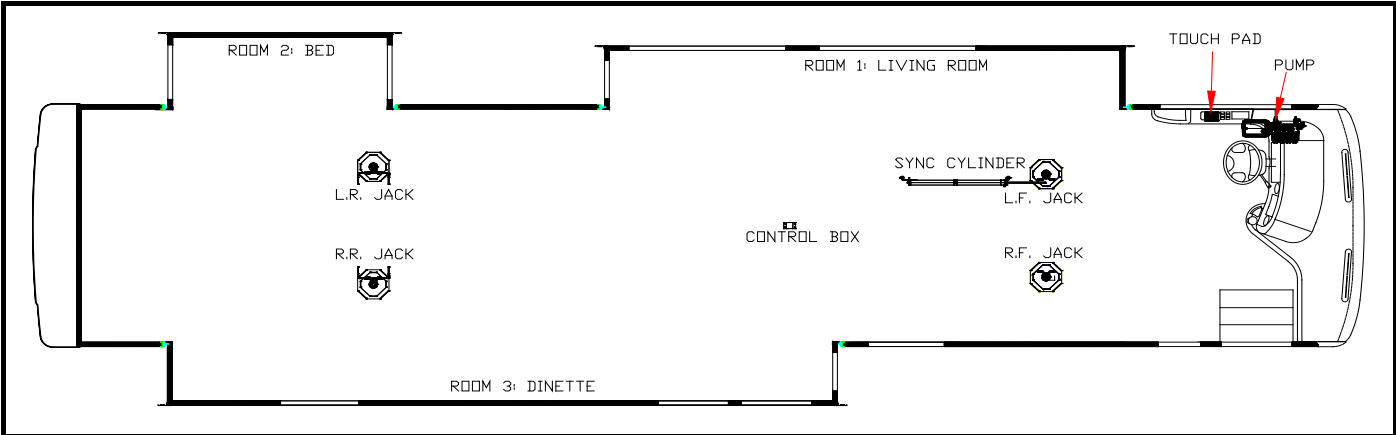

- Notes:**
- 1) Jacks mount to chassis brackets with the lowest holes of the jacks aligned with the lowest holes of the mounting brackets.
 - 2) Level sensor attaches to bottom of structure; on the square tube the runs full length from axle to axle.
 - 3) Hydraulic hose terminations for room #1 & #3 require 90 degree swivel elbows.
 - 4) Hoses marked w90 will have the 90 deg fitting shipped loose.

Item, Length	Description / Location	Qty	Color	Vendor PN		
Kit	(Items listed below)	1		8373		
Pump	7-Function, 3 Rooms & Jacks	1		7319BR		
Jack	17,000 lbs, 18" Stroke	4		7134		
Touch Pad	Located to the left of the drivers seat	1		2318	<p align="center">Measuring from inside of firewall, this is the end location of the hydraulic hoses where they attach to the slide mechanism.</p>	
Control Box	Attached to bottom of structure	1		2730		
Sync Cylinder	Mounted behind LP tank	2		7397		
Hose, 144	Pump to Jack, Left Front	2	Brown	2467		
Hose, 408	Pump to Jack, Left Rear	2	Orange	2484		
Hose, 144	Pump to Jack, Right Front	2	White	2467		
Hose, 408	Pump to Jack, Right Rear	1	Yellow	2484		
Hose, 108	Left Rear Jack, Right Rear Jack	1	Yel/Ora.	2464		
Hose, 168	Pump to synchronizing cylinder	2	Green	2469		Mounts to bracket on structure
Hose w90, 168	Sync cylinder to front slide, Room 1	2	Green	2469		130 / Drivers side
Hose w90, 168	Sync cylinder to rear slide, Room 1	2	Green	2469	220 / Drivers side	
Slide Unit	Room 1 - 24" flush floor slide (angled)	2		7388		
Hose, 516	Pump to Room 2	2	Purple	2491	420 / Drivers Side	
Slide Unit	Room 2 - 30" Bed slide (Lippert)	1		134998		
Hose, 168	Pump to synchronizing cylinder	2	Gray	2469	Mounts to bracket on structure	
Hose w90, 360	Sync cylinder to front slide, Room 3	2	Gray	2527	235 / Passenger side	
Hose w90, 360	Sync cylinder to rear slide, Room 3	2	Gray	2527	385 / Passenger side	
Slide Unit	Room 3 - 24" flush floor slide (angled)	2		7388		
	Pump to Generator Slide	N/A			N/A	
Travel Clamp	(two per slide, except the bed slide)	4		HWH	N/A	
Options						
Revisions						
1						

42B Presidio
EQUALIZER JACKS (FULLY AUTOMATIC)
STANDARD ON THIS UNIT

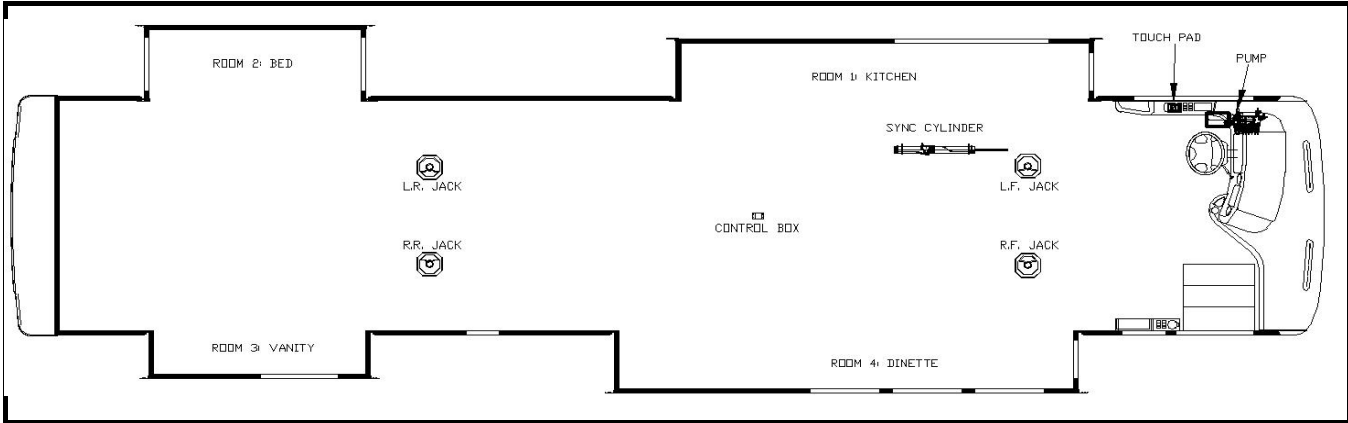

- Notes:**
- 1) Jacks mount to chassis brackets with the lowest holes of the jacks aligned with the lowest holes of the mounting brackets.
 - 2) Level sensor attaches to bottom of structure; on the square tube the runs full length from axle to axle.
 - 3) Hydraulic hose terminations for room #1 & #3 require 90 degree swivel elbows.
 - 4) Hoses marked w90 will have the 90 deg fitting shipped loose.

Item, Length	Description / Location	Qty	Color	Vendor PN		
Kit	(Items listed below)	1		8379	Measuring from inside of firewall, this is the end location of the hydraulic hoses where they attach to the slide mechanism.	
Pump	8-Function, 4 Rooms & Jacks	1		7302BR		
Jack	17,000 lbs, 18" Stroke	4		7134		
Touch Pad	Located to the left of the drivers seat	1		2318		
Control Box	Attached to bottom of structure	1		2730		
Sync Cylinder	Mounted behind LP tank	2		7397		
Hose, 144	Pump to Jack, Left Front	2	Brown	2467		
Hose, 408	Pump to Jack, Left Rear	2	Orange	2484		
Hose, 144	Pump to Jack, Right Front	2	White	2467		
Hose, 408	Pump to Jack, Right Rear	1	Yellow	2484		
Hose, 108	Left Rear Jack, Right Rear Jack	1	Yel/Ora.	2464		
Hose, 168	Pump to synchronizing cylinder	2	Green	2469		Mounts to bracket on structure
Hose w90, 168	Sync cylinder to front slide, Room 1	2	Green	2469		115 / Drivers side
Hose w90, 168	Sync cylinder to rear slide, Room 1	2	Green	2469		205 / Drivers side
Slide Unit	Room 1 - 24" flush floor slide (angled)	2		7388		
Hose, 516	Pump to Room 2	2	Purple	2491	420 / Drivers Side	
Slide Unit	Room 2 - 30" Bed slide (Lippert)	1		134998		
Hose w90, 516	Pump to Room 3	2	Gray	2491	404 / Passenger side	
Slide Unit	Room 3 - 18" above floor slide	1		7135		
Hose, 168	Pump to synchronizing cylinder	2	Red	2469	Mounts to bracket on structure	
Hose w90, 288	Sync cylinder to front slide, Room 4	2	Red	2478	115 / Passenger side	
Hose w90, 288	Sync cylinder to rear slide, Room 4	2	Red	2478	254 / Passenger side	
Slide Unit	Room 4 - 24" flush floor slide (angled)	2		7388		
	Pump to Generator Slide	N/A			N/A	
Travel Clamp	(two per slide, except the bed slide)	6		HWH	N/A	

Options					

Revisions					
1					

**38D Presidio
EQUALIZER JACKS (FULLY AUTOMATIC)
STANDARD ON THIS UNIT**

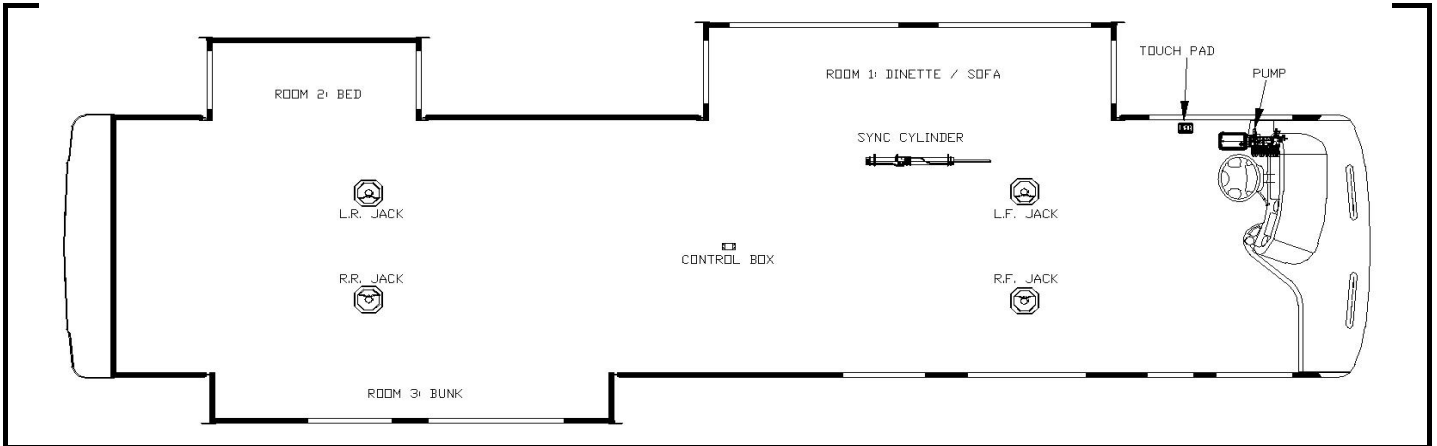

Notes:

- 1) Jacks mount to chassis brackets with the lowest holes of the jacks aligned with the lowest holes of the mounting brackets.
- 2) Level sensor attaches to bottom of structure; on lower hat section flanges or square tube.
- 3) Hydraulic hose terminations for room #1 & #3 require 90 degree swivel elbows.
- 4) Reference FM-3991 for a better visual of Room 1 hydraulic connections.
- 5) Hoses marked w90 will have the 90 deg fitting shipped loose.

Item, Length	Description / Location	Qty	Color	Vendor PN	
Kit	(Items listed below)	1		8347	
Pump	7-Function, 3 Rooms & Jacks	1		7319BR	
Jack	17,000 lbs, 18" Stroke	4		7134	
Touch Pad	Located to the left of the drivers seat	1		2318	
Control Box	Attached to bottom of structure	1		2730	
Sync Cylinder	Mounted behind LP tank	1		7387	
Hose, 132	Pump to Jack, Left Front	2	Brown	2466	
Hose, 384	Pump to Jack, Left Rear	2	Orange	2482	
Hose, 144	Pump to Jack, Right Front	2	White	2467	
Hose, 396	Pump to Jack, Right Rear	1	Yellow	2483	
Hose, 108	Left Rear Jack, Right Rear Jack	1	Yel/Ora	2464	
Hose, 144	Pump to synchronizing manifold	2	Green	2467	Mounts to bracket on structure
Hose w90, 168	Sync cylinder to front slide, Room 1	2	Green	2469	103 / Drivers side
Hose w90, 168	Sync cylinder to rear slide, Room 1	2	Green	2469	196 / Drivers side
	Pump to Room 1	N/A	Green		
Slide Unit	Room 1 - 36" flush floor slide	2		7523	
Hose, 444	Pump to Room 2	2	Purple	2487	325 / Drivers Side
Slide Unit	Room 2 - 30" Bed slide (Lippert)	1		134998	
Hose w90, 468	Pump to Room 3	2	Gray	2489	355 / Passenger Side
Slide Unit	Room 3 - 18" above floor slide	1		7135	
	Pump to Generator Slide	N/A			
Travel Clamp	(two per slide, dinette / sofa slide only)	2		HWH	N/A

Measuring from inside of firewall, this is the end location of the hydraulic hoses where they attach to the slide mechanism.

Options

Revisions

1	4-7-08, Corrected part number for 36" room, requires angled 36" in-floor mechanism #7523
2	4-23-08, Updated to match EQ's new way of plumbing jacks.

**38E Presidio
EQUALIZER JACKS (FULLY AUTOMATIC)
STANDARD ON THIS UNIT**

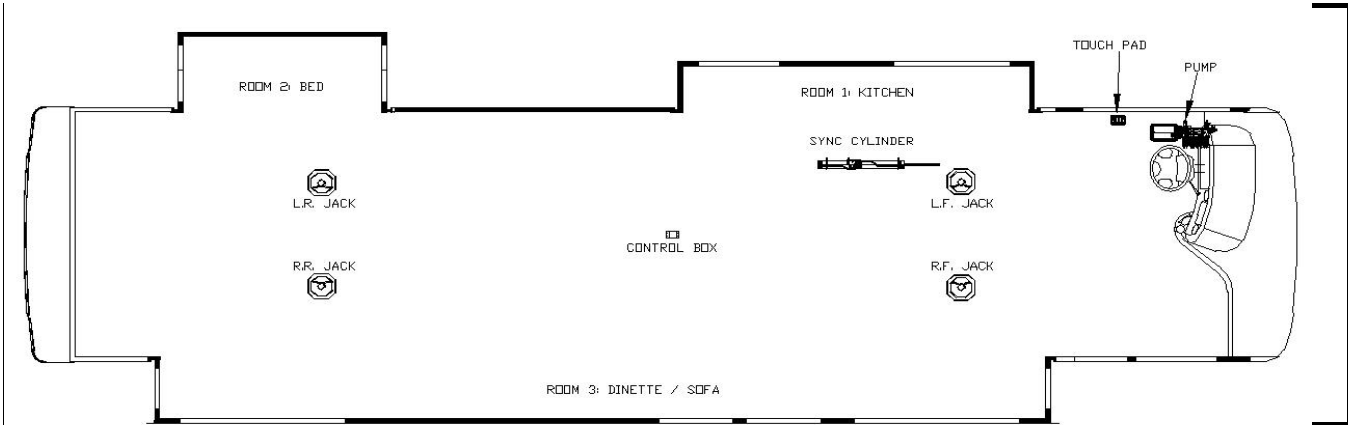

- 1) Jacks mount to chassis brackets with the lowest holes of the jacks aligned with the lowest holes of the mounting brackets.
- 2) Level sensor attaches to bottom of structure; on the square tube the runs full length from axle to axle.
- 3) Hydraulic hose terminations for room #2 & #3 require 90 degree swivel elbows.
- 4) Room #3 will have a non-powered slide mechanism in center of room
- 5) Hoses marked w90 will have the 90 deg fitting shipped loose.

Item, Length	Description / Location	Qty	Color	Vendor PN		
Kit	(Items listed below)	1		8350	Measuring from inside of firewall, this is the end location of the hydraulic hoses where they attach to the slide mechanism.	
Pump	7-Function, 3 Rooms & Jacks	1		7319BR		
Jack	17,000 lbs, 18" Stroke	4		7134		
Touch Pad	Located to the left of the drivers seat	1		2318		
Control Box	Attached to bottom of structure	1		2730		
Sync Cylinder	Mounted behind LP tank	1		7397		
Hose, 144	Pump to Jack, Left Front	2	Brown	2467		
Hose, 420	Pump to Jack, Left Rear	2	Orange	2485		
Hose, 144	Pump to Jack, Right Front	2	White	2467		
Hose, 420	Pump to Jack, Right Rear	1	Yellow	2485		
Hose, 108	Left Rear Jack, Right Rear Jack	1	Yel/ Ora	2464		
Hose, 144	Pump to synchronizing cylinder	2	Gray	2467		Mounts to bracket on structure
Hose w90, 432	Sync cylinder to front slide, Room 3	2	Gray	2486		103 / Passenger Side
Hose w90, 444	Sync cylinder to rear slide, Room 3	2	Gray	2487		350 / Passenger Side
Slide Unit	Room 3 - 24" flush floor slide (angled)	2		7388		
Slide Unit	Room 3 - 24" flush floor slide (angled)	1		7384	Slave	
Hose w90, 180	Pump to Room 1	2	Green	2470	146 / Drivers Side	
Slide Unit	Room 1 - 18" above floor slide	1		7135		
Hose, 516	Pump to Room 2	2	Purple	2491	345 / Drivers Side	
Slide Unit	Room 2 - 30" Bed slide (Lippert)	1		134998		
	Pump to Generator Slide	N/A			N/A	
Travel Clamp	(two per slide, except the bed slide)	4		HWH	N/A	

Options

Revisions

1	4-23-08, Updated to match EQ's new way of plumbing jacks.

**40J Presidio
EQUALIZER JACKS (FULLY AUTOMATIC)
STANDARD ON THIS UNIT**

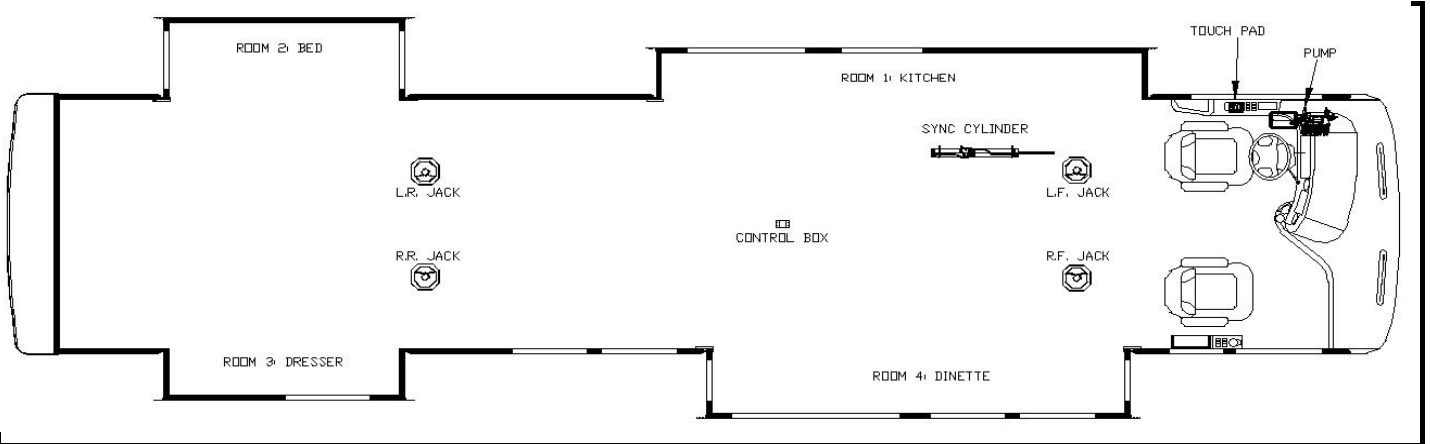

Notes:

- 1) Jacks mount to chassis brackets with the lowest holes of the jacks aligned with the lowest holes of the mounting brackets.
- 2) Level sensor attaches to bottom of structure; on the square tube the runs full length from axle to axle.
- 3) Hydraulic hose terminations for room #1, #3, & #4 require 90 degree swivel elbows.
- 4) Reference FM-3991 for a better visual of Room 4 hydraulic connections.
- 5) Hoses marked w90 will have the 90 deg fitting shipped loose.

Item, Length	Description / Location	Qty	Color	Vendor PN	
Kit	(Items listed below)	1		8421	
Pump	8-Function, 4 Rooms & Jacks	1		7302BR	
Jack	17,000 lbs, 18" Stroke	4		7134	
Touch Pad	Located to the left of the drivers seat	1		2318	
Control Box	Attached to bottom of structure	1		2730	
Sync Cylinder	Mounted behind LP tank	1		7397	
Sync Cylinder	Mounted behind LP tank	1		7511	
Hose, 144	Pump to Jack, Left Front	2	Brown	2467	
Hose, 408	Pump to Jack, Left Rear	2	Orange	2484	
Hose, 144	Pump to Jack, Right Front	2	White	2467	
Hose, 408	Pump to Jack, Right Rear	1	Yellow	2484	
Hose, 108	Left Rear Jack, Right Rear Jack	1	Yel/ Ora	2464	
Hose, 192	Pump to synchronizing cylinder	2	Green	2471	Mounts to bracket on structure
Hose w90, 144	Sync cylinder to front slide, Room 1	2	Green	2467	124 / Drivers side
Hose w90, 144	Sync cylinder to rear slide, Room 1	2	Green	2467	214 / Drivers side
Slide Unit	Room 1 - 18" above floor slide	2		7135	
Hose, 480	Pump to Room 2	2	Purple	2490	386 / Drivers Side
Slide Unit	Room 2 - 30" Bed slide (Lippert)	1		134998	
Hose w90, 480	Pump to Room 3	2	Gray	2490	365 / Passenger Side
Slide Unit	Room 3 - 18" above floor slide	1		7135	
Hoes, 192	Pump to synchronizing cylinder	2	Red	2471	Mounts to bracket on structure
Hose w90, 144	Sync cylinder to front slide, Room 4	2	Red	2467	124 / Passenger side
Hose w90, 144	Sync cylinder to rear slide, Room 4	2	Red	2467	214 / Passenger side
Slide Unit	Room 4 - 24" flush floor slide	2		7388	
	Pump to Generator Slide	N/A			N/A
Travel Clamp	(two per slide, except the bed slide)	6		HWH	N/A

Measuring from inside of firewall, this is the end location of the hydraulic hoses where they attach to the slide mechanism.

Options

Revisions

1	4-23-08, Updated to match EQ's new way of plumbing jacks.

**40K Presidio
EQUALIZER JACKS (FULLY AUTOMATIC)
STANDARD ON THIS UNIT**

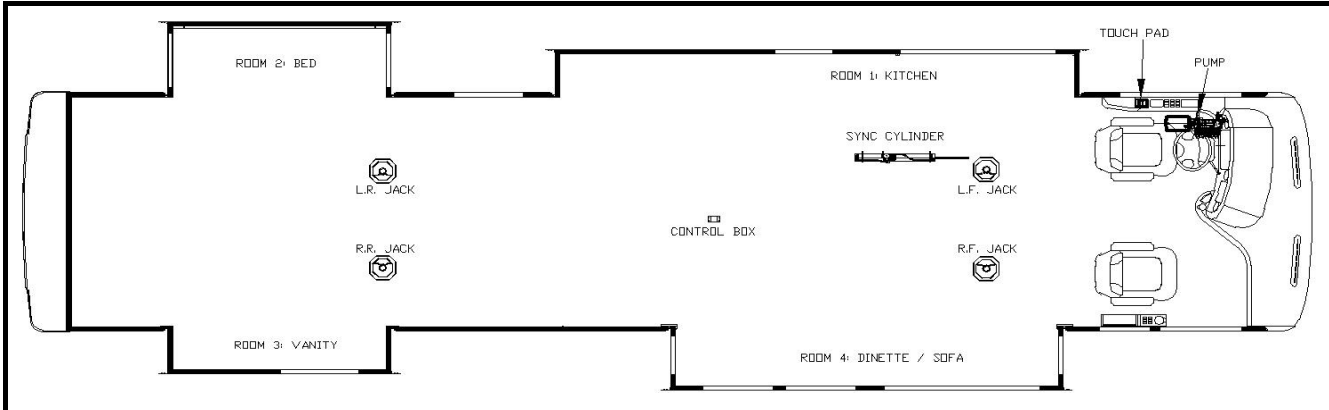

- Notes:**
- 1) Jacks mount to chassis brackets with the lowest holes of the jacks aligned with the lowest holes of the mounting brackets.
 - 2) Level sensor attaches to bottom of structure; on the square tube the runs full length from axle to axle.
 - 3) Hydraulic hose terminations for room #1, #3, & #4 require 90 degree swivel elbows.
 - 4) Reference FM-3991 for a better visual of Room 4 hydraulic connections.
 - 5) Hoses marked w90 will have the 90 deg fitting shipped loose.

Item, Length	Description / Location	Qty	Color	Vendor PN		
Kit	(Items listed below)	1		8418	Measuring from inside of firewall, this is the end location of the hydraulic hoses where they attach to the slide mechanism.	
Pump	8-Function, 4 Rooms & Jacks	1		7302BR		
Jack	17,000 lbs, 18" Stroke	4		7134		
Touch Pad	Located to the left of the drivers seat	1		2318		
Control Box	Attached to bottom of structure	1		2730		
Sync Cylinder	Mounted behind LP tank	1		7397		
Sync Cylinder	Mounted behind LP tank	1		7511		
Hose, 144	Pump to Jack, Left Front	2	Brown	2467		
Hose, 408	Pump to Jack, Left Rear	2	Orange	2484		
Hose, 144	Pump to Jack, Right Front	2	White	2467		
Hose, 408	Pump to Jack, Right Rear	1	Yellow	2484		
Hose, 108	Left Rear Jack, Right Rear Jack	1	Yel/ Ora	2464		
Hose, 192	Pump to synchronizing cylinder	2	Green	2471		Mounts to bracket on structure
Hose w90, 144	Sync cylinder to front slide, Room 1	2	Green	2467		124 / Drivers side
Hose w90, 144	Sync cylinder to rear slide, Room 1	2	Green	2467	214 / Drivers side	
Slide Unit	Room 1 - 18" above floor slide	2		7135		
Hose, 480	Pump to Room 2	2	Purple	2490	386 / Drivers Side	
Slide Unit	Room 2 - 30" Bed slide (Lippert)	1		134998		
Hose w90, 480	Pump to Room 3	2	Gray	2490	365 / Passenger Side	
Slide Unit	Room 3 - 18" above floor slide	1		7135		
Hose, 192	Pump to synchronizing cylinder	2	Red	2471	Mounts to bracket on structure	
Hose w90, 144	Sync cylinder to front slide, Room 4	2	Red	2467	124 / Passenger side	
Hose w90, 144	Sync cylinder to rear slide, Room 4	2	Red	2467	214 / Passenger side	
Slide Unit	Room 4 - 24" flush floor slide	2		7388		
	Pump to Generator Slide	N/A			N/A	
Travel Clamp	(two per slide, except the bed slide)	6		HWH	N/A	

Options					

Revisions	
1	4-23-08, Updated to match EQ's new way of plumbing jacks.

**42A Presidio
EQUALIZER JACKS (FULLY AUTOMATIC)
STANDARD ON THIS UNIT**

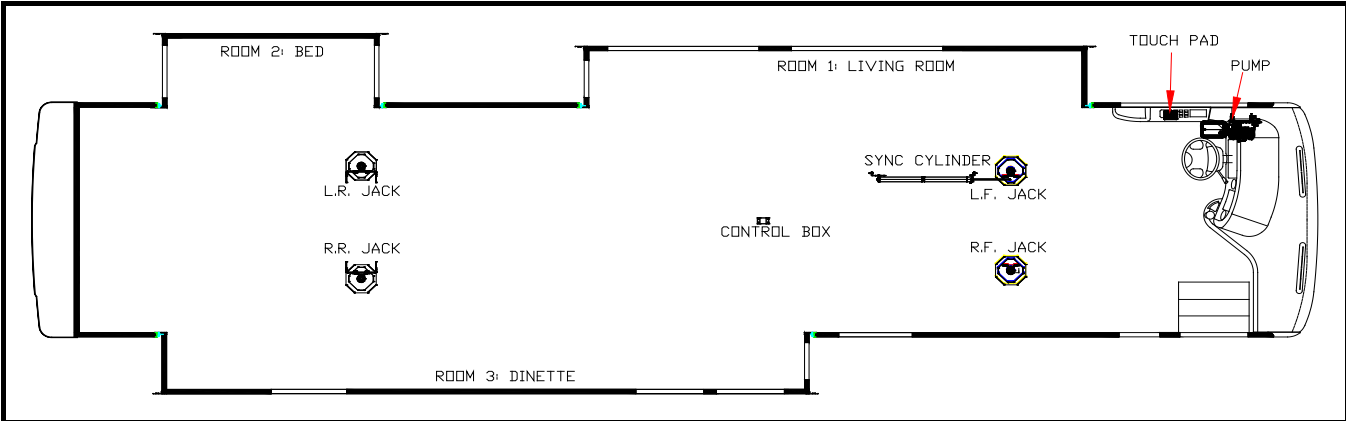

- Notes:**
- 1) Jacks mount to chassis brackets with the lowest holes of the jacks aligned with the lowest holes of the mounting brackets.
 - 2) Level sensor attaches to bottom of structure; on the square tube the runs full length from axle to axle.
 - 3) Hydraulic hose terminations for room #1 & #3 require 90 degree swivel elbows.
 - 4) Hoses marked w90 will have the 90 deg fitting shipped loose.

Item, Length	Description / Location	Qty	Color	Vendor PN		
Kit	(Items listed below)	1		8373	Measuring from inside of firewall, this is the end location of the hydraulic hoses where they attach to the slide mechanism.	
Pump	7-Function, 3 Rooms & Jacks	1		7319BR		
Jack	17,000 lbs, 18" Stroke	4		7134		
Touch Pad	Located to the left of the drivers seat	1		2318		
Control Box	Attached to bottom of structure	1		2730		
Sync Cylinder	Mounted behind LP tank	2		7397		
Hose, 144	Pump to Jack, Left Front	2	Brown	2467		
Hose, 408	Pump to Jack, Left Rear	2	Orange	2484		
Hose, 144	Pump to Jack, Right Front	2	White	2467		
Hose, 408	Pump to Jack, Right Rear	1	Yellow	2484		
Hose, 108	Left Rear Jack, Right Rear Jack	1	Yel/ Ora	2464		
Hose, 168	Pump to synchronizing cylinder	2	Green	2469		Mounts to bracket on structure
Hose w90, 168	Sync cylinder to front slide, Room 1	2	Green	2469		130 / Drivers side
Hose w90, 168	Sync cylinder to rear slide, Room 1	2	Green	2469		220 / Drivers side
Slide Unit	Room 1 - 24" flush floor slide (angled)	2		7388		
Hose, 516	Pump to Room 2	2	Purple	2491	420 / Drivers Side	
Slide Unit	Room 2 - 30" Bed slide (Lippert)	1		134998		
Hose, 168	Pump to synchronizing cylinder	2	Gray	2469	Mounts to bracket on structure	
Hose w90, 360	Sync cylinder to front slide, Room 3	2	Gray	2527	235 / Passenger side	
Hose w90, 360	Sync cylinder to rear slide, Room 3	2	Gray	2527	385 / Passenger side	
Slide Unit	Room 3 - 24" flush floor slide (angled)	2		7388		
	Pump to Generator Slide	N/A			N/A	
Travel Clamp	(two per slide, except the bed slide)	4		HWH	N/A	

Options

Revisions

1	4-23-08, Updated to match EQ's new way of plumbing jacks.

**42B Presidio
EQUALIZER JACKS (FULLY AUTOMATIC)
STANDARD ON THIS UNIT**

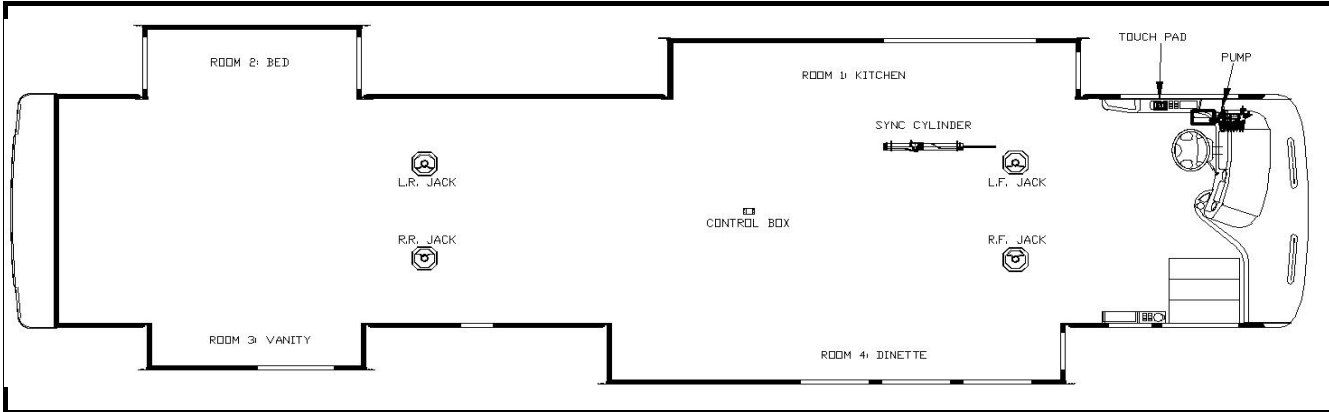

Notes:

- 1) Jacks mount to chassis brackets with the lowest holes of the jacks aligned with the lowest holes of the mounting brackets.
- 2) Level sensor attaches to bottom of structure; on the square tube the runs full length from axle to axle.
- 3) Hydraulic hose terminations for room #1 & #3 require 90 degree swivel elbows.
- 4) Hoses marked w90 will have the 90 deg fitting shipped loose.

Item, Length	Description / Location	Qty	Color	Vendor PN		
Kit	(Items listed below)	1		8379	Measuring from inside of firewall, this is the end location of the hydraulic hoses where they attach to the slide mechanism.	
Pump	8-Function, 4 Rooms & Jacks	1		7302BR		
Jack	17,000 lbs, 18" Stroke	4		7134		
Touch Pad	Located to the left of the drivers seat	1		2318		
Control Box	Attached to bottom of structure	1		2730		
Sync Cylinder	Mounted behind LP tank	2		7397		
Hose, 144	Pump to Jack, Left Front	2	Brown	2467		
Hose, 408	Pump to Jack, Left Rear	2	Orange	2484		
Hose, 144	Pump to Jack, Right Front	2	White	2467		
Hose, 408	Pump to Jack, Right Rear	1	Yellow	2484		
Hose, 108	Left Rear Jack, Right Rear Jack	1	Yel/ Ora	2464		
Hose, 168	Pump to synchronizing cylinder	2	Green	2469		Mounts to bracket on structure
Hose w90, 168	Sync cylinder to front slide, Room 1	2	Green	2469		115 / Drivers side
Hose w90, 168	Sync cylinder to rear slide, Room 1	2	Green	2469		205 / Drivers side
Slide Unit	Room 1 - 24" flush floor slide (angled)	2		7388		
Hose, 516	Pump to Room 2	2	Purple	2491	420 / Drivers Side	
Slide Unit	Room 2 - 30" Bed slide (Lippert)	1		134998		
Hose w90, 516	Pump to Room 3	2	Gray	2491	404 / Passenger side	
Slide Unit	Room 3 - 18" above floor slide	1		7135		
Hose, 168	Pump to synchronizing cylinder	2	Red	2469	Mounts to bracket on structure	
Hose w90, 288	Sync cylinder to front slide, Room 4	2	Red	2478	115 / Passenger side	
Hose w90, 288	Sync cylinder to rear slide, Room 4	2	Red	2478	254 / Passenger side	
Slide Unit	Room 4 - 24" flush floor slide (angled)	2		7388		
	Pump to Generator Slide	N/A			N/A	
Travel Clamp	(two per slide, except the bed slide)	6		HWH	N/A	

Options

Revisions

1	4-23-08, Updated to match EQ's new way of plumbing jacks.

**40G Mandalay
EQUALIZER JACKS (FULLY AUTOMATIC)
STANDARD ON THIS UNIT**

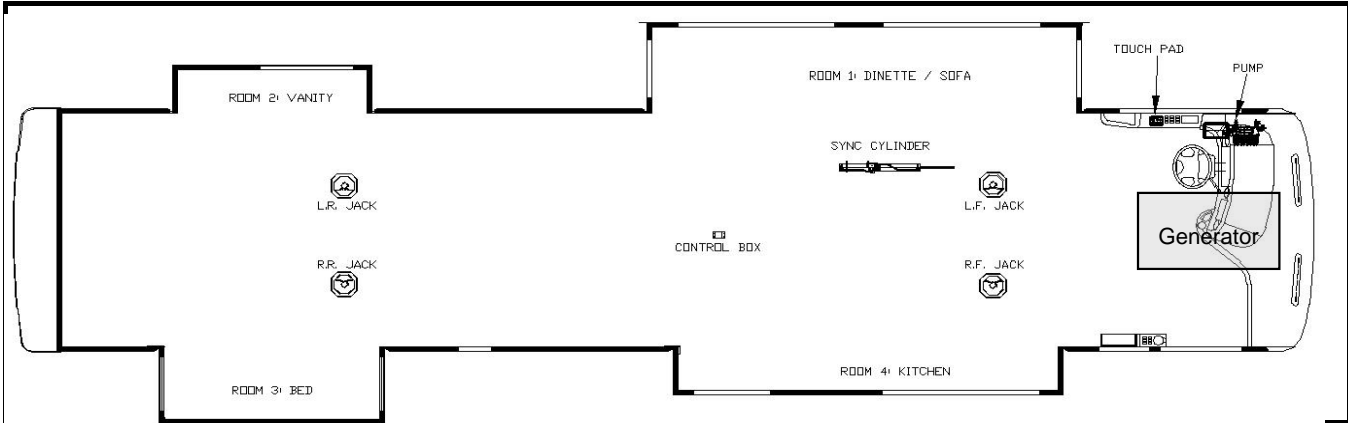

Notes:

- 1) Jacks mount to chassis brackets providing 8-9 inches of ground clearance with the air bags dumped.
- 2) Level sensor attaches to bottom of structure; on lower hat section flanges or square tube.
- 3) Hydraulic hose terminations for room #1, #3, & #4 require 90 degree swivel elbows.
- 4) Hoses marked w90 will have the 90 deg. Fitting shipped loose

Item, Length	Description / Location	Qty	Color	Vendor PN	
Kit	(Items listed below)	1		8359	
Pump	9-Function, 4 Rooms, & Jacks	1		7464BR	
Jack	17,000 lbs, 18" Stroke	4		7134	
Touch Pad	Located to the left of the drivers seat	1		2318	
Control Box	Attached to bottom of structure	1		2730	
Sync Cylinder	Mounted behind LP tank	1		7387	
Hose, 144	Pump to Jack, Left Front	2	Brown	2467	
Hose, 480	Pump to Jack, Left Rear	2	Orange	2490	
Hose, 144	Pump to Jack, Right Front	2	White	2467	
Hose, 480	Pump to Jack, Right Rear	1	Yellow	2490	
Hose, 108	Left Rear Jack, Right Rear Jack	1	Yel/Ora.	2464	
Hose, 180	Pump to synchronizing cylinder	2	Green	2470	mounts to bracket on structure
Hose w90, 168	Sync cylinder to front slide, Room 1	2	Green	2469	99 / Drivers side
Hose w90, 168	Sync cylinder to rear slide, Room 1	2	Green	2469	201 / Drivers side
Slide Unit	Room 1 - 36" flush floor slide	2		7467	
Hose w90, 432	Pump to Room 2	2	Purple	2486	373 / Drivers Side
Slide Unit	Room 2 - 18" above floor slide	1		7469	
Hose, 480	Pump to Room 3	2	Gray	2490	352 / Passenger Side
Slide Unit	Room 2 - 30" Bed slide (Lippert)	1		134998	
Hose w90, 228	Pump to Room 4	2	Red	2474	153 / Passenger Side
Slide Unit	Room 4 - 18" above floor slide	1		7469	
Hose, 60	Pump to Generator Slide	2	Blue	2460	Inside generator tray
Travel Clamp	(two per slide, except the bed slide)	6		HWH	N/A

Measuring from inside of firewall, this is the end location of the hydraulic hoses where they attach to the slide mechanism.

Options

Revisions

12/6/2007	Added slide mechanism part numbers to chart.

43A Mandalay
EQUALIZER JACKS (FULLY AUTOMATIC)
STANDARD ON THIS UNIT

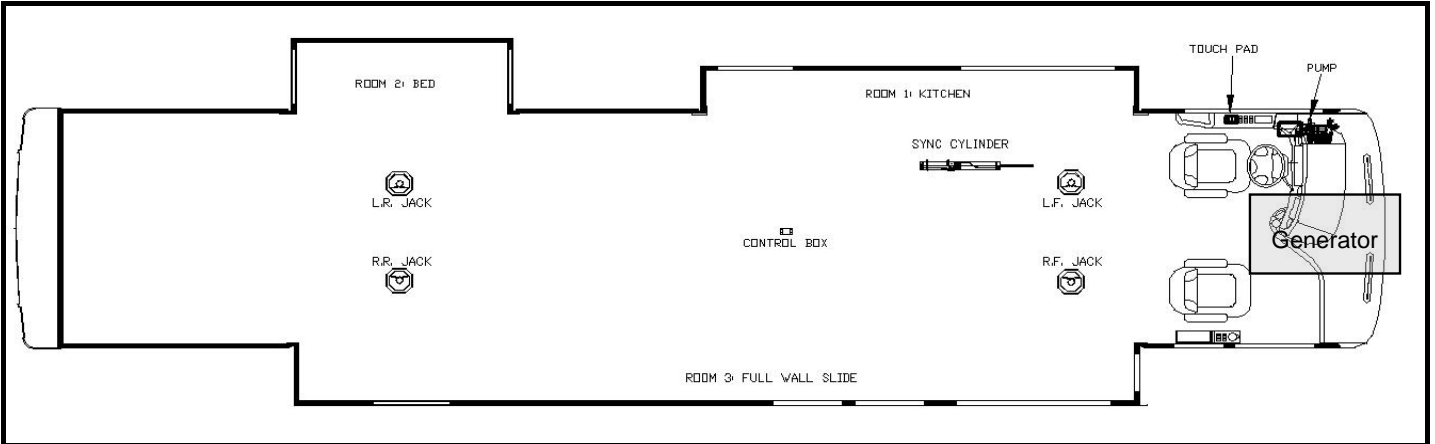

Notes:

- 1) Jacks mount to chassis brackets providing 8-9 inches of ground clearance with the air bags dumped.
- 2) Level sensor attaches to bottom of structure; on lower hat section flanges or square tube.
- 3) Hydraulic hose terminations for room #1 & #3 require 90 degree swivel elbows.
- 4) Hoses marked w90 will have the 90 deg. Fitting shipped loose
- 5) All in floor slides to have automatic travel lock sensor

Item, Length	Description / Location	Qty	Color	Vendor PN	
Kit	(Items listed below)	1		8360	
Pump	8-Function, 3 Rooms, & Jacks	1		7474BR	
Jack	17,000 lbs, 18" Stroke	4		7134	
Touch Pad	Located to the left of the drivers seat	1		2318	
Control Box	Attached to bottom of structure	1		2730	
Sync Cylinder	Mounted behind LP tank	1		7397	
Hose, 144	Pump to Jack, Left Front	2	Brown	2467	
Hose, 480	Pump to Jack, Left Rear	2	Orange	2490	
Hose, 144	Pump to Jack, Right Front	2	White	2467	
Hose, 480	Pump to Jack, Right Rear	1	Yellow	2490	
Hose, 108	Left Rear Jack, Right Rear Jack	1	Yel/Ora	2464	
Hose, 180	Pump to synchronizing cylinder	2	Grey	2470	Mounts to bracket on structure
Hose, 216	Pump to Room 1	2	Green	2473	165 / Drivers Side
Slide Unit	Room 1 - 18" above floor slide	1		7469	
Hose w90, 516	Pump to Room 2	2	Purple	2491	408 / Drivers Side
Slide Unit	Room 2 - 30" Bed slide (Lippert)	1		134998	
Hose w90, 288	Sync cylinder to front slide, Room 3	2	Grey	2478	90 / Passenger side
Hose w90, 288	Sync cylinder to rear slide, Room 3	2	Grey	2478	378 / Passenger side
Slide Unit	Room 3 - 24" flush floor slide (angled)	2		7477	
Slide Unit	Room 3 - 24" flush floor slide (angled)	1		7384	Slave
Hose, 60	Pump to Generator Slide	2	Red	2460	Inside generator tray
Travel Clamp	(two per slide, except the bed slide)	4		HWH	N/A

Measuring from inside of firewall, this is the end location of the hydraulic hoses where they attach to the slide mechanism.

Options

Revisions

1	Corrected the bed slide Vendor Part No. Was 143960.	8-15-07 JS
2	Changed Pump to Room 2 hose length from 516" to 480".	12/3/07 KK

43C Mandalay
EQUALIZER JACKS (FULLY AUTOMATIC)
STANDARD ON THIS UNIT

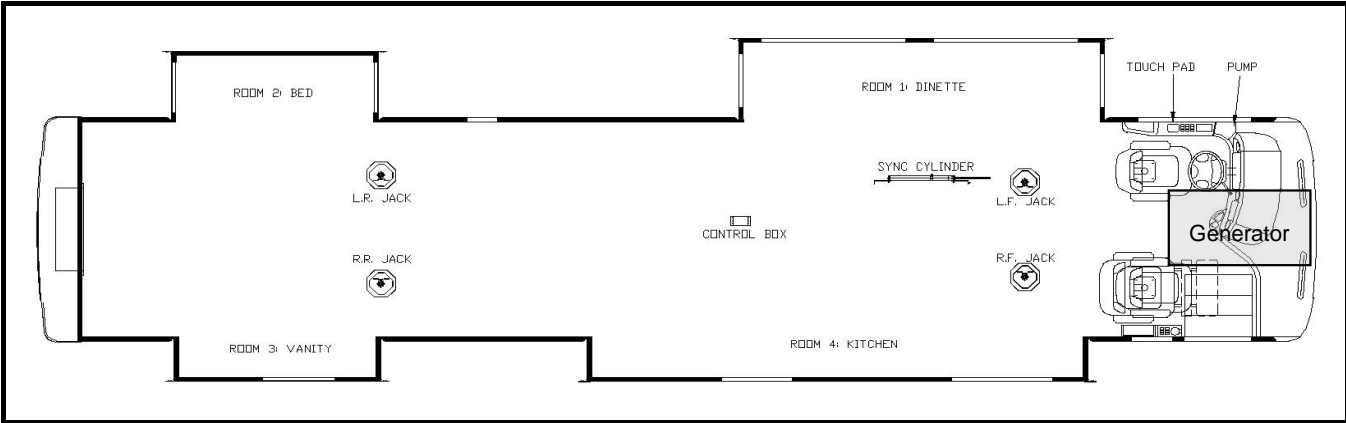

Notes:

- 1) Jacks mount to chassis brackets providing 8-9 inches of ground clearance with the air bags dumped.
- 2) Level sensor attaches to bottom of structure; on lower hat section flanges or square tube.
- 3) Hydraulic hose terminations for room #1, #3 & #4 require 90 degree swivel elbows.
- 4) Hoses marked w90 will have the 90 deg. Fitting shipped loose
- 5) All in floor slides to have automatic travel lock sensor

Item, Length	Description / Location	Qty	Color	Vendor PN	
Kit	(Items listed below)	1		8377	
Pump	9-Function, 4 Rooms, & Jacks	1		7464BR	
Jack	17,000 lbs, 18" Stroke	4		7134	
Touch Pad	Located to the left of the drivers seat	1		2318	
Control Box	Attached to bottom of structure	1		2730	
Sync Cylinder	Mounted behind LP tank, Room 1	1		7387	
Sync Cylinder	Mounted behind LP tank, Room 4	1		7511	
Hose, 144	Pump to Jack, Left Front	2	Brown	2467	
Hose, 480	Pump to Jack, Left Rear	2	Orange	2490	
Hose, 144	Pump to Jack, Right Front	2	White	2467	
Hose, 480	Pump to Jack, Right Rear	1	Yellow	2490	
Hose, 108	Left Rear Jack, Right Rear Jack	1	Yel/Ora.	2464	
Hose, 180	Pump to synchronizing cylinder	2	Green	2470	Mounts to bracket on structure
Hose w90, 168	Sync cylinder to front slide, Room 1	2	Green	2469	99 / Drivers Side
Hose w90, 168	Sync cylinder to rear slide, Room 1	2	Green	2469	187 / Drivers Side
Slide Unit	Room 1 - 36" flush floor slide (angled)	2		7481	
Hose, 516	Pump to room 2	2	Purple	2491	408 / Drivers Side
Slide Unit	Room 2 - 30" Bed slide (Lippert)	1		134998	
Hose w90, 456	Pump to Room 3	2	Grey	2488	408 / Passenger side
Slide Unit	Room 3 - 18" above floor slide	1		7469	
Hose, 180	Pump to synchronizing cylinder	2	Red	2470	Mounts to bracket on structure
Hose w90, 228	Sync cylinder to front slide, Room 4	2	Red	2474	135 / Passenger Side
Hose w90, 228	Sync cylinder to rear slide, Room 4	2	Red	2474	220 / Passenger Side
Slide Unit	Room 4 - 18" above floor slide	2		7469	
Hose, 60	Pump to Generator Slide	2	Blue	2460	Inside generator tray
Travel Clamp	(two per slide, except the bed slide)	6		HWH	N/A

Measuring from inside of firewall, this is the end location of the hydraulic hoses where they attach to the slide mechanism.

Options

Revisions

1	Changed Pump to Room 2 hose length from 432" to 516".	12/3/07	KK

**43D Mandalay
EQUALIZER JACKS (FULLY AUTOMATIC)
STANDARD ON THIS UNIT**

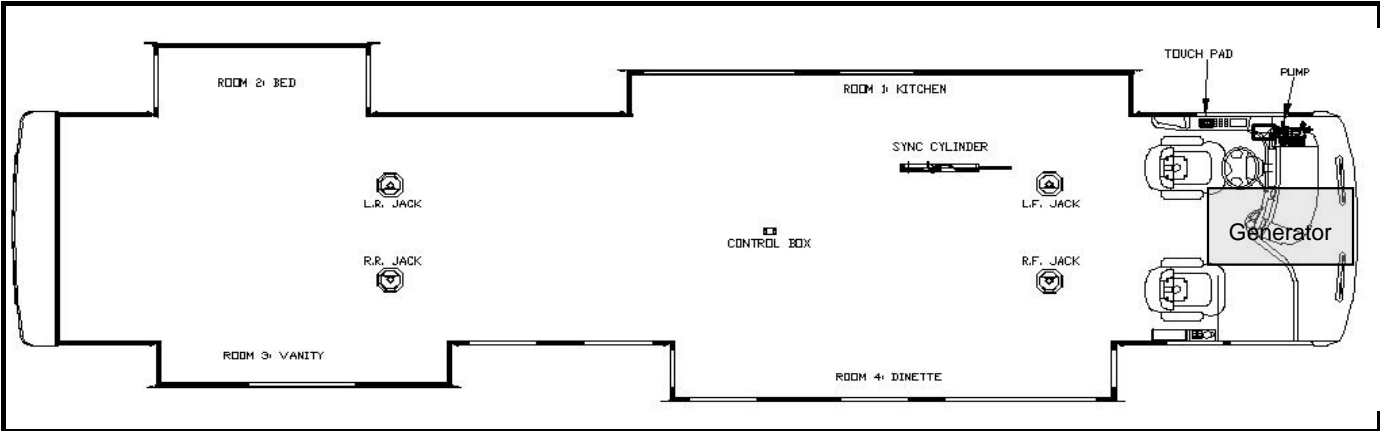

Notes:

- 1) Jacks mount to chassis brackets providing 8-9 inches of ground clearance with the air bags dumped.
- 2) Level sensor attaches to bottom of structure; on lower hat section flanges or square tube.
- 3) Hydraulic hose terminations for room #1, #3 & #4 require 90 degree swivel elbows.
- 4) Hoses marked w90 will have the 90 deg. Fitting shipped loose
- 5) All in floor slides to have automatic travel lock sensor

Item, Length	Description / Location	Qty	Color	Vendor PN	
Kit	(Items listed below)	1		8419	
Pump	9-Function, 4 Rooms, & Jacks	1		7464BR	
Jack	17,000 lbs, 18" Stroke	4		7134	
Touch Pad	Located to the left of the drivers seat	1		2318	
Control Box	Attached to bottom of structure	1		2730	
Sync Cylinder	Mounted behind LP tank	1		7397	
Sync Cylinder	Mounted behind LP tank	1		7511	
Hose, 144	Pump to Jack, Left Front	2	Brown	2467	
Hose, 480	Pump to Jack, Left Rear	2	Orange	2490	
Hose, 144	Pump to Jack, Right Front	2	White	2467	
Hose, 480	Pump to Jack, Right Rear	1	Yellow	2490	
Hose, 108	Right Rear Jack, Left Rear Jack	1	Yel/Ora.	2464	
Hose, 144	Pump to synchronizing cylinder	2	Green	2467	Mounts to bracket on structure
Hose w90, 204	Sync cylinder to front slide, Room 1	2	Green	2472	123 / Drivers Side
Hose w90, 204	Sync cylinder to rear slide, Room 1	2	Green	2472	210 / Drivers Side
Slide Unit	Room 1 - 18" above floor slide	1		7469	
Hose, 516	Pump to Room 2	2	Purple	2491	408 / Drivers Side
Slide Unit	Room 2 - 30" Bed slide (Lippert)	1		134998	
Hose w90, 480	Pump to Room 3	2	Grey	2490	408 / Passenger side
Slide Unit	Room 3 - 18" above floor slide	1		7469	
Hose, 144	Pump to synchronizing cylinder	2	Red	2467	Mounts to bracket on structure
Hose w90, 216	Sync cylinder to front slide, Room 4	2	Red	2473	123 / Passenger side
Hose w90, 216	Sync cylinder to rear slide, Room 4	2	Red	2473	210 / Passenger side
Slide Unit	Room 4 - 24" flush floor slide (angled)	2		7477	
Hose, 60	Pump to Generator Slide	2	Blue	2460	Inside generator tray
Travel Clamp	(two per slide, except the bed slide)	6		HWH	N/A

Measuring from inside of firewall, this is the end location of the hydraulic hoses where they attach to the slide mechanism.

Options

Revisions

1	
2	
3	
4	

**40G Mandalay
EQUALIZER JACKS (FULLY AUTOMATIC)
STANDARD ON THIS UNIT**

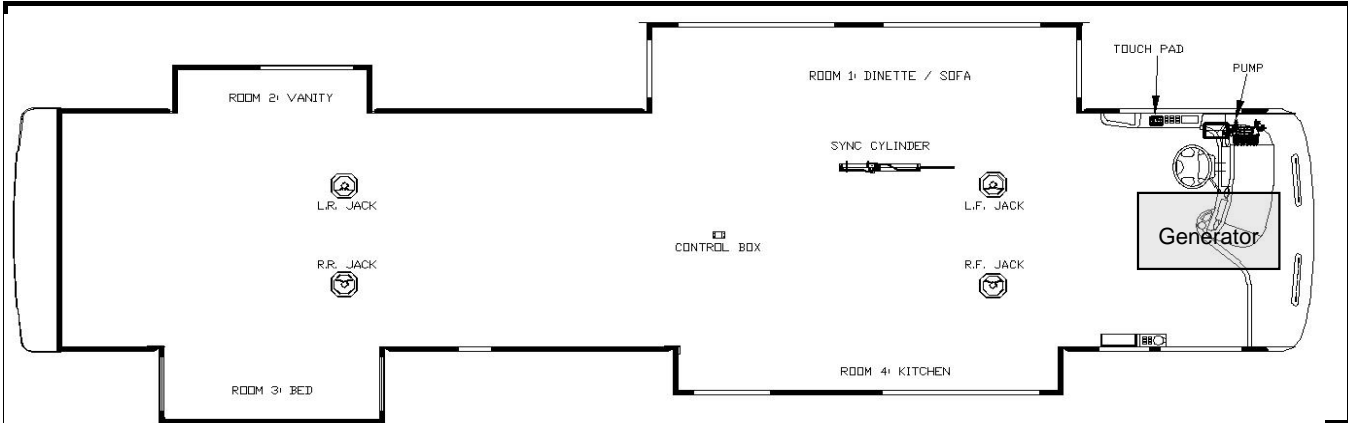

Notes:

- 1) Jacks mount to chassis brackets providing 8-9 inches of ground clearance with the air bags dumped.
- 2) Level sensor attaches to bottom of structure; on lower hat section flanges or square tube.
- 3) Hydraulic hose terminations for room #1, #3, & #4 require 90 degree swivel elbows.
- 4) Hoses marked w90 will have the 90 deg. Fitting shipped loose

Item, Length	Description / Location	Qty	Color	Vendor PN		
Kit	(Items listed below)	1		8359	Measuring from inside of firewall, this is the end location of the hydraulic hoses where they attach to the slide mechanism.	
Pump	9-Function, 4 Rooms, & Jacks	1		7464BR		
Jack	17,000 lbs, 18" Stroke	4		7134		
Touch Pad	Located to the left of the drivers seat	1		2318		
Control Box	Attached to bottom of structure	1		2730		
Sync Cylinder	Mounted behind LP tank	1		7387		
Hose, 144	Pump to Jack, Left Front	2	Brown	2467		
Hose, 480	Pump to Jack, Left Rear	2	Orange	2490		
Hose, 144	Pump to Jack, Right Front	2	White	2467		
Hose, 480	Pump to Jack, Right Rear	1	Yellow	2490		
Hose, 108	Left Rear Jack, Right Rear Jack	1	Yel/ Ora	2464		
Hose, 180	Pump to synchronizing cylinder	2	Green	2467		mounts to bracket on structure
Hose w90, 168	Sync cylinder to front slide, Room 1	2	Green	2469		99 / Drivers side
Hose w90, 168	Sync cylinder to rear slide, Room 1	2	Green	2469		201 / Drivers side
Slide Unit	Room 1 - 36" flush floor slide	2		7467		
Hose w90, 432	Pump to Room 2	2	Purple	2486	373 / Drivers Side	
Slide Unit	Room 2 - 18" above floor slide	1		7469		
Hose, 480	Pump to Room 3	2	Gray	2490	352 / Passenger Side	
Slide Unit	Room 2 - 30" Bed slide (Lippert)	1		134998		
Hose w90, 228	Pump to Room 4	2	Red	2474	153 / Passenger Side	
Slide Unit	Room 4 - 18" above floor slide	1		7469		
Hose, 60	Pump to Generator Slide	2	Blue	2460	Inside generator tray	
Travel Clamp	(two per slide, except the bed slide)	6		HWH	N/A	
Options						
Revisions						
12/6/2007	Added slide mechanism part numbers to chart.					
4/23/2008	Updated to match EQ's new way of plumbing jacks.					

**43A Mandalay
EQUALIZER JACKS (FULLY AUTOMATIC)
STANDARD ON THIS UNIT**

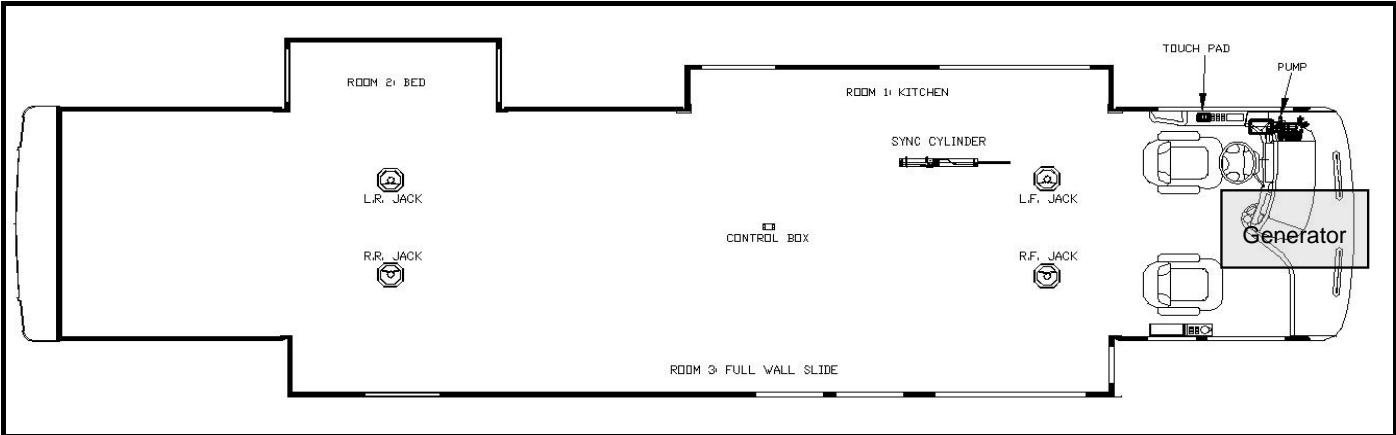

Notes:

- 1) Jacks mount to chassis brackets providing 8-9 inches of ground clearance with the air bags dumped.
- 2) Level sensor attaches to bottom of structure; on lower hat section flanges or square tube.
- 3) Hydraulic hose terminations for room #1 & #3 require 90 degree swivel elbows.
- 4) Hoses marked w90 will have the 90 deg. Fitting shipped loose
- 5) All in floor slides to have automatic travel lock sensor

Item, Length	Description / Location	Qty	Color	Vendor PN	
Kit	(Items listed below)	1		8360	
Pump	8-Function, 3 Rooms, & Jacks	1		7474BR	
Jack	17,000 lbs, 18" Stroke	4		7134	
Touch Pad	Located to the left of the drivers seat	1		2318	
Control Box	Attached to bottom of structure	1		2730	
Sync Cylinder	Mounted behind LP tank	1		7397	
Hose, 144	Pump to Jack, Left Front	2	Brown	2467	
Hose, 480	Pump to Jack, Left Rear	2	Orange	2490	
Hose, 144	Pump to Jack, Right Front	2	White	2467	
Hose, 480	Pump to Jack, Right Rear	1	Yellow	2490	
Hose, 108	Left Rear Jack, Right Rear Jack	1	Yel/ Ora	2464	
Hose, 180	Pump to synchronizing cylinder	2	Grey	2470	Mounts to bracket on structure
Hose, 216	Pump to Room 1	2	Green	2473	165 / Drivers Side
Slide Unit	Room 1 - 18" above floor slide	1		7469	
Hose w90, 516	Pump to Room 2	2	Purple	2491	408 / Drivers Side
Slide Unit	Room 2 - 30" Bed slide (Lippert)	1		134998	
Hose w90, 336	Sync cylinder to front slide, Room 3	2	Grey	2535	90 / Passenger side
Hose w90, 336	Sync cylinder to rear slide, Room 3	2	Grey	2535	378 / Passenger side
Slide Unit	Room 3 - 24" flush floor slide (angled)	2		7477	
Slide Unit	Room 3 - 24" flush floor slide (angled)	1		7384	Slave
Hose, 60	Pump to Generator Slide	2	Red	2460	Inside generator tray
Travel Clamp	(two per slide, except the bed slide)	4		HWH	N/A

Measuring from inside of firewall, this is the end location of the hydraulic hoses where they attach to the slide mechanism.

Options/ Notes

Note	Options/ Notes				
Note 1	Sync cylinder position			Rear	

Revisions

1	Corrected the bed slide Vendor Part No. Was 143960.	8-15-07	JS
2	Changed Pump to Room 2 hose length from 516" to 480".	12/3/07	KK
3	4-23-08, Updated to match EQ's new way of plumbing jacks.		

**43C Mandalay
EQUALIZER JACKS (FULLY AUTOMATIC)
STANDARD ON THIS UNIT**

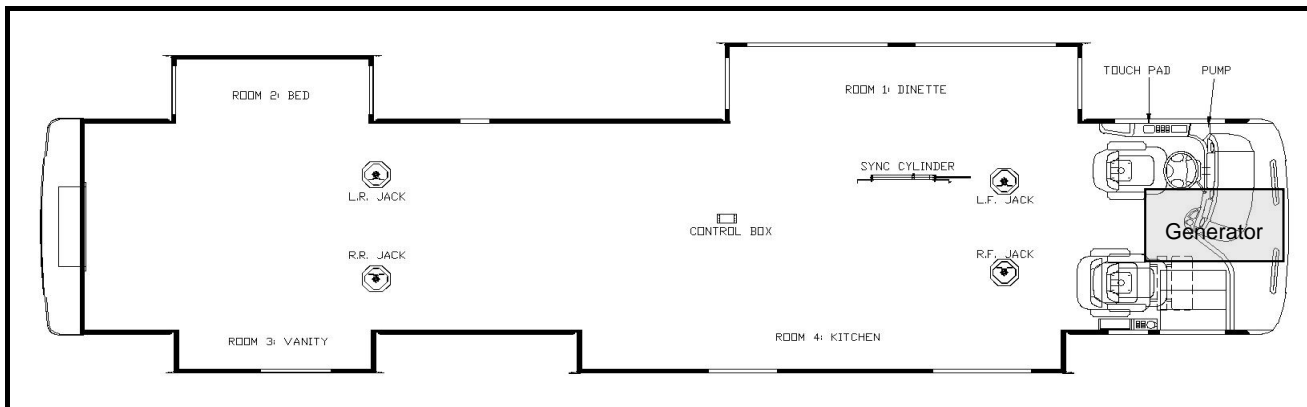

Notes:

- 1) Jacks mount to chassis brackets providing 8-9 inches of ground clearance with the air bags dumped.
- 2) Level sensor attaches to bottom of structure; on lower hat section flanges or square tube.
- 3) Hydraulic hose terminations for room #1, #3 & #4 require 90 degree swivel elbows.
- 4) Hoses marked w90 will have the 90 deg. Fitting shipped loose
- 5) All in floor slides to have automatic travel lock sensor

Item, Length	Description / Location	Qty	Color	Vendor PN	
Kit	(Items listed below)	1		8377	
Pump	9-Function, 4 Rooms, & Jacks	1		7464BR	
Jack	17,000 lbs, 18" Stroke	4		7134	
Touch Pad	Located to the left of the drivers seat	1		2318	
Control Box	Attached to bottom of structure	1		2730	
Sync Cylinder	Mounted behind LP tank, Room 1	1		7387	
Sync Cylinder	Mounted behind LP tank, Room 4	1		7511	
Hose, 144	Pump to Jack, Left Front	2	Brown	2467	
Hose, 480	Pump to Jack, Left Rear	2	Orange	2490	
Hose, 144	Pump to Jack, Right Front	2	White	2467	
Hose, 480	Pump to Jack, Right Rear	1	Yellow	2490	
Hose, 108	Left Rear Jack, Right Rear Jack	1	Yel/ Ora	2464	
Hose, 180	Pump to synchronizing cylinder	2	Green	2470	Mounts to bracket on structure
Hose w90, 168	Sync cylinder to front slide, Room 1	2	Green	2469	99 / Drivers Side
Hose w90, 168	Sync cylinder to rear slide, Room 1	2	Green	2469	187 / Drivers Side
Slide Unit	Room 1 - 36" flush floor slide (angled)	2		7481	
Hose, 516	Pump to Room 2	2	Purple	2491	408 / Drivers Side
Slide Unit	Room 2 - 30" Bed slide (Lippert)	1		134998	
Hose w90, 456	Pump to Room 3	2	Grey	2488	408 / Passenger side
Slide Unit	Room 3 - 18" above floor slide	1		7469	
Hose, 180	Pump to synchronizing cylinder	2	Red	2470	Mounts to bracket on structure
Hose w90, 228	Sync cylinder to rear slide, Room 4	2	Red	2474	135 / Passenger Side
Hose w90, 228	Sync cylinder to rear slide, Room 4	2	Red	2474	220 / Passenger Side
Slide Unit	Room 4 - 18" above floor slide	2		7469	
Hose, 60	Pump to Generator Slide	2	Blue	2460	Inside generator tray
Travel Clamp	(two per slide, except the bed slide)	6		HWH	N/A

Measuring from inside of firewall, this is the end location of the hydraulic hoses where they attach to the slide mechanism.

Mounts to bracket on structure
99 / Drivers Side
187 / Drivers Side
408 / Drivers Side
408 / Passenger side
MOUNTS TO BRACKET ON STRUCTURE
135 / Passenger Side
220 / Passenger Side
Inside generator tray
N/A

Options/ Notes

Note 1	Sync cylinder position				Rear

Revisions

1	Changed Pump to Room 2 hose length from 432" to 516".	12/3/07	KK
2	4-23-08, Updated to match EQ's new way of plumbing jacks.		

**43D Mandalay
EQUALIZER JACKS (FULLY AUTOMATIC)
STANDARD ON THIS UNIT**

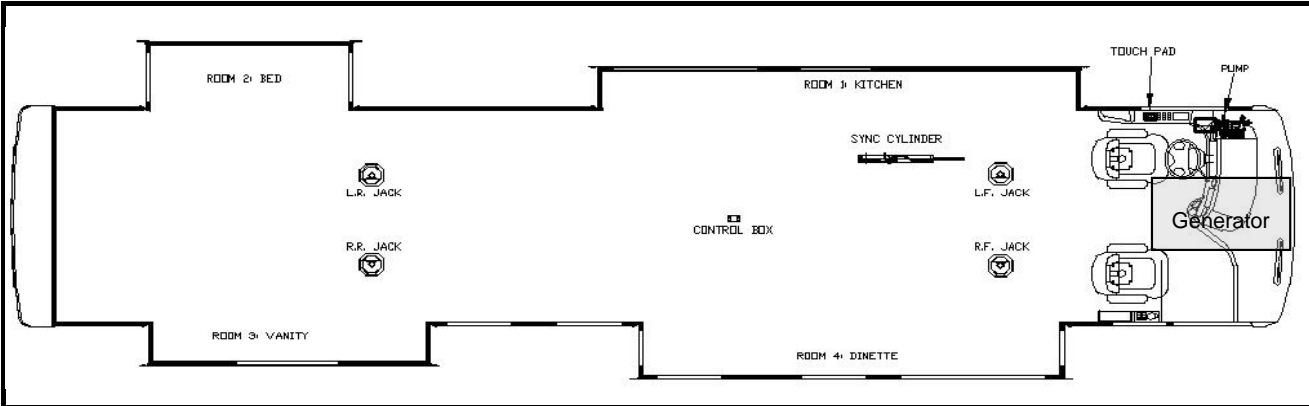

Notes:

- 1) Jacks mount to chassis brackets providing 8-9 inches of ground clearance with the air bags dumped.
- 2) Level sensor attaches to bottom of structure; on lower hat section flanges or square tube.
- 3) Hydraulic hose terminations for room #1, #3 & #4 require 90 degree swivel elbows.
- 4) Hoses marked w90 will have the 90 deg. Fitting shipped loose
- 5) All in floor slides to have automatic travel lock sensor

Item, Length	Description / Location	Qty	Color	Vendor PN	
Kit	(Items listed below)	1		8419	
Pump	9-Function, 4 Rooms, & Jacks	1		7464BR	
Jack	17,000 lbs, 18" Stroke	4		7134	
Touch Pad	Located to the left of the drivers seat	1		2318	
Control Box	Attached to bottom of structure	1		2730	
Sync Cylinder	Mounted behind LP tank	1		7397	
Sync Cylinder	Mounted behind LP tank	1		7511	
Hose, 144	Pump to Jack, Left Front	2	Brown	2467	
Hose, 480	Pump to Jack, Left Rear	2	Orange	2490	
Hose, 144	Pump to Jack, Right Front	2	White	2467	
Hose, 480	Pump to Jack, Right Rear	1	Yellow	2490	
Hose, 108	Left Rear Jack, Right Rear Jack	1	Yel/ Ora	2464	
Hose, 144	Pump to synchronizing cylinder	2	Green	2467	Mounts to bracket on structure
Hose w90, 204	Sync cylinder to front slide, Room 1	2	Green	2472	123 / Drivers Side
Hose w90, 204	Sync cylinder to rear slide, Room 1	2	Green	2472	210 / Drivers Side
Slide Unit	Room 1 - 18" above floor slide	2		7469	
Hose, 516	Pump to Room 2	2	Purple	2491	408 / Drivers Side
Slide Unit	Room 2 - 30" Bed slide (Lippert)	1		134998	
Hose w90, 480	Pump to Room 3	2	Grey	2490	408 / Passenger side
Slide Unit	Room 3 - 18" above floor slide	1		7469	
Hose, 144	Pump to synchronizing cylinder	2	Red	2467	Mounts to bracket on structure
Hose w90, 216	Sync cylinder to front slide, Room 4	2	Red	2473	123 / Passenger side
Hose w90, 216	Sync cylinder to rear slide, Room 4	2	Red	2473	210 / Passenger side
Slide Unit	Room 4 - 24" flush floor slide (angled)	2		7477	
Hose, 60	Pump to Generator Slide	2	Blue	2460	Inside generator tray
Travel Clamp	(two per slide, except the bed slide)	6		HWH	N/A

Measuring from inside of firewall, this is the end location of the hydraulic hoses where they attach to the slide mechanism.

Options/ Notes

Note 1	Sync cylinder position	Front			

Revisions

1	4-23-08, Updated to match EQ's new way of plumbing jacks.
2	
3	
4	

**40G Mandalay
EQUALIZER JACKS (FULLY AUTOMATIC)
STANDARD ON THIS UNIT**

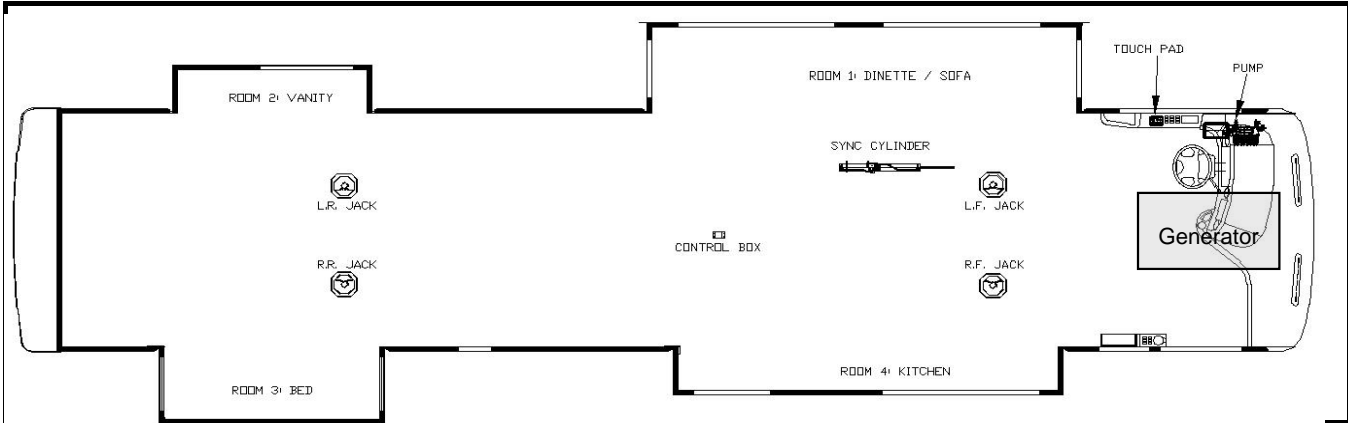

Notes:

- 1) Jacks mount to chassis brackets providing 8-9 inches of ground clearance with the air bags dumped.
- 2) Level sensor attaches to bottom of structure; on lower hat section flanges or square tube.
- 3) Hydraulic hose terminations for room #1, #3, & #4 require 90 degree swivel elbows.
- 4) Hoses marked w90 will have the 90 deg. Fitting shipped loose

Item, Length	Description / Location	Qty	Color	Vendor PN		
Kit	(Items listed below)	1		8359	Measuring from inside of firewall, this is the end location of the hydraulic hoses where they attach to the slide mechanism.	
Pump	9-Function, 4 Rooms, & Jacks	1		7464BR		
Jack	17,000 lbs, 18" Stroke	4		7134		
Touch Pad	Located to the left of the drivers seat	1		2318		
Control Box	Attached to bottom of structure	1		2730		
Sync Cylinder	Mounted behind LP tank	1		7387		
Hose, 144	Pump to Jack, Left Front	2	Brown	2467		
Hose, 480	Pump to Jack, Left Rear	2	Orange	2490		
Hose, 144	Pump to Jack, Right Front	2	White	2467		
Hose, 480	Pump to Jack, Right Rear	1	Yellow	2490		
Hose, 108	Left Rear Jack, Right Rear Jack	1	Yel/ Ora	2464		
Hose, 180	Pump to synchronizing cylinder	2	Green	2467		mounts to bracket on structure
Hose w90, 168	Sync cylinder to front slide, Room 1	2	Green	2469		99 / Drivers side
Hose w90, 168	Sync cylinder to rear slide, Room 1	2	Green	2469		201 / Drivers side
Slide Unit	Room 1 - 36" flush floor slide	2		7467		
Hose w90, 432	Pump to Room 2	2	Purple	2486	373 / Drivers Side	
Slide Unit	Room 2 - 18" above floor slide	1		7469		
Hose, 480	Pump to Room 3	2	Gray	2490	352 / Passenger Side	
Slide Unit	Room 2 - 30" Bed slide (Lippert)	1		134998		
Hose w90, 228	Pump to Room 4	2	Red	2474	153 / Passenger Side	
Slide Unit	Room 4 - 18" above floor slide	1		7469		
Hose, 60	Pump to Generator Slide	2	Blue	2460	Inside generator tray	
Travel Clamp	(two per slide, except the bed slide)	6		HWH	N/A	
Options						
Revisions						
12/6/2007	Added slide mechanism part numbers to chart.					
4/23/2008	Updated to match EQ's new way of plumbing jacks.					

43A Mandalay
EQUALIZER JACKS (FULLY AUTOMATIC)
STANDARD ON THIS UNIT

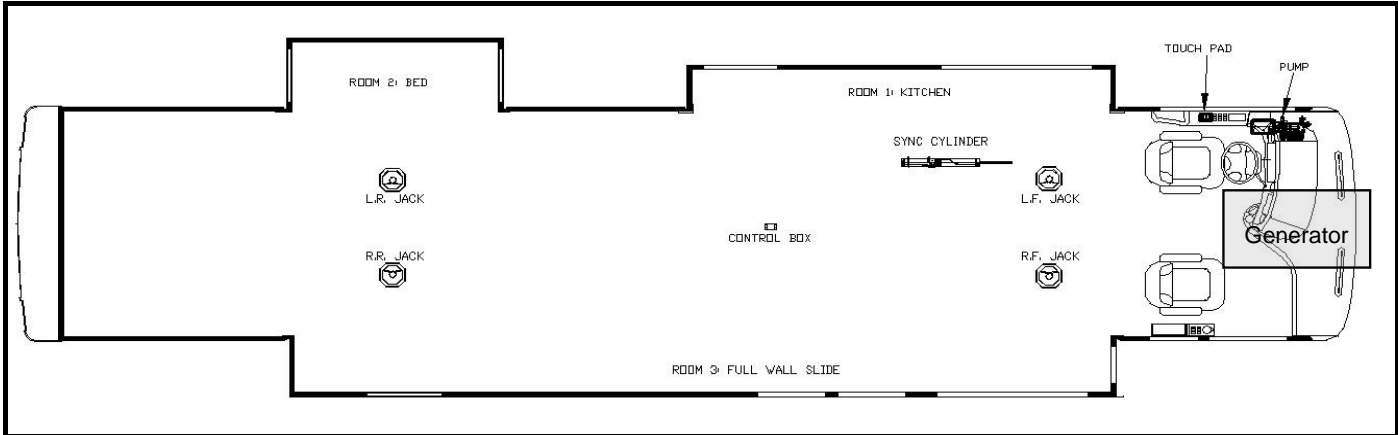

Notes:

- 1) Jacks mount to chassis brackets providing 8-9 inches of ground clearance with the air bags dumped.
- 2) Level sensor attaches to bottom of structure; on lower hat section flanges or square tube.
- 3) Hydraulic hose terminations for room #1 & #3 require 90 degree swivel elbows.
- 4) Hoses marked w90 will have the 90 deg. Fitting shipped loose
- 5) All in floor slides to have automatic travel lock sensor

Item, Length	Description / Location	Qty	Color	Vendor PN	
Kit	(Items listed below)	1		8360	
Pump	8-Function, 3 Rooms, & Jacks	1		7474BR	
Jack	17,000 lbs, 18" Stroke	4		7134	
Touch Pad	Located to the left of the drivers seat	1		2318	
Control Box	Attached to bottom of structure	1		2730	
Sync Cylinder	Mounted behind LP tank	1		7397	
Sync Cylinder	Mounted behind LP tank	1		7511	
Hose, 144	Pump to Jack, Left Front	2	Brown	2467	
Hose, 480	Pump to Jack, Left Rear	2	Orange	2490	
Hose, 144	Pump to Jack, Right Front	2	White	2467	
Hose, 480	Pump to Jack, Right Rear	1	Yellow	2490	
Hose, 108	Left Rear Jack, Right Rear Jack	1	Yel/ Ora	2464	
Hose, 180	Pump to synchronizing cylinder	2	Green	2470	Mounts to bracket on structure
Hose w90, 168	Sync cylinder to front slide, Room 1	2	Green	2469	105 / Drivers Side
Hose w90, 168	Sync cylinder to rear slide, Room 1	2	Green	2469	200 / Drivers Side
Slide Unit	Room 1 - 18" above floor slide	2		7469	
Hose w90, 516	Pump to Room 2	2	Purple	2491	408 / Drivers Side
Slide Unit	Room 2 - 30" Bed slide (Lippert)	1		134998	
Hose, 180	Pump to synchronizing cylinder	2	Grey	2470	Mounts to bracket on structure
Hose w90, 336	Sync cylinder to front slide, Room 3	2	Grey	2535	90 / Passenger side
Hose w90, 336	Sync cylinder to rear slide, Room 3	2	Grey	2535	378 / Passenger side
Slide Unit	Room 3 - 24" flush floor slide (angled)	2		7477	
Slide Unit	Room 3 - 24" flush floor slide (angled)	1		7384	Slave
Hose, 60	Pump to Generator Slide	2	Red	2460	Inside generator tray
Travel Clamp	(two per slide, except the bed slide)	4		HWH	N/A

Measuring from inside of firewall, this is the end location of the hydraulic hoses where they attach to the slide mechanism.

Options/ Notes

Note 1	Sync cylinder position				Rear

Revisions

1	Corrected the bed slide Vendor Part No. Was 143960.	8-15-07	JS
2	Changed Pump to Room 2 hose length from 516" to 480".	12/3/07	KK
3	4-23-08, Updated to match EQ's new way of plumbing jacks.		
4	Changed Room 1 to two slides-Starts with unit 3629		

**43C Mandalay
EQUALIZER JACKS (FULLY AUTOMATIC)
STANDARD ON THIS UNIT**

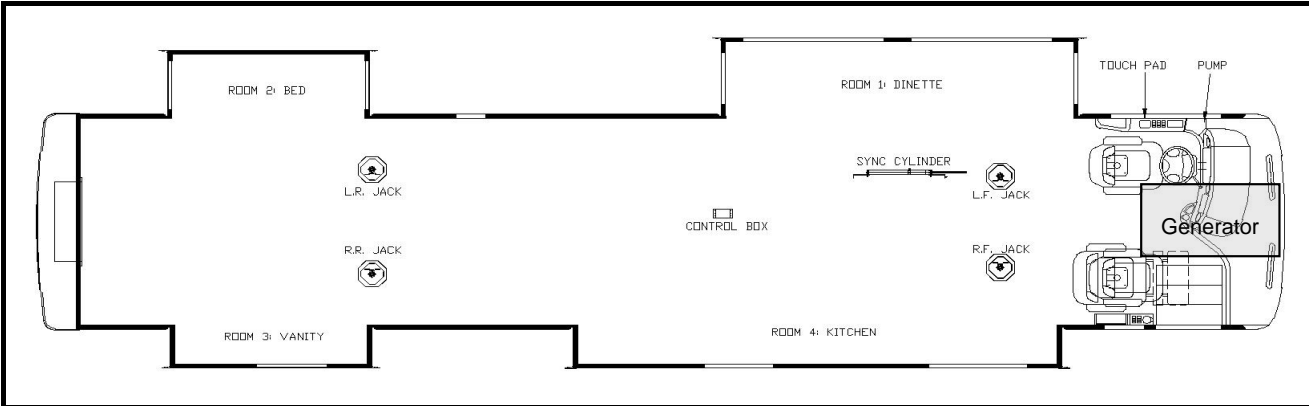

Notes:

- 1) Jacks mount to chassis brackets providing 8-9 inches of ground clearance with the air bags dumped.
- 2) Level sensor attaches to bottom of structure; on lower hat section flanges or square tube.
- 3) Hydraulic hose terminations for room #1, #3 & #4 require 90 degree swivel elbows.
- 4) Hoses marked w90 will have the 90 deg. Fitting shipped loose
- 5) All in floor slides to have automatic travel lock sensor

Item, Length	Description / Location	Qty	Color	Vendor PN	
Kit	(Items listed below)	1		8377	
Pump	9-Function, 4 Rooms, & Jacks	1		7464BR	
Jack	17,000 lbs, 18" Stroke	4		7134	
Touch Pad	Located to the left of the drivers seat	1		2318	
Control Box	Attached to bottom of structure	1		2730	
Sync Cylinder	Mounted behind LP tank, Room 1	1		7387	
Sync Cylinder	Mounted behind LP tank, Room 4	1		7511	
Hose, 144	Pump to Jack, Left Front	2	Brown	2467	
Hose, 480	Pump to Jack, Left Rear	2	Orange	2490	
Hose, 144	Pump to Jack, Right Front	2	White	2467	
Hose, 480	Pump to Jack, Right Rear	1	Yellow	2490	
Hose, 108	Left Rear Jack, Right Rear Jack	1	Yel/ Ora	2464	
Hose, 180	Pump to synchronizing cylinder	2	Green	2470	Mounts to bracket on structure
Hose w90, 168	Sync cylinder to front slide, Room 1	2	Green	2469	99 / Drivers Side
Hose w90, 168	Sync cylinder to rear slide, Room 1	2	Green	2469	187 / Drivers Side
Slide Unit	Room 1 - 36" flush floor slide (angled)	2		7481	
Hose, 516	Pump to Room 2	2	Purple	2491	408 / Drivers Side
Slide Unit	Room 2 - 30" Bed slide (Lippert)	1		134998	
Hose w90, 456	Pump to Room 3	2	Grey	2488	408 / Passenger side
Slide Unit	Room 3 - 18" above floor slide	1		7469	
Hose, 180	Pump to synchronizing cylinder	2	Red	2470	Mounts to bracket on structure
Hose w90, 228	Sync cylinder to rear slide, Room 4	2	Red	2474	135 / Passenger Side
Hose w90, 228	Sync cylinder to rear slide, Room 4	2	Red	2474	220 / Passenger Side
Slide Unit	Room 4 - 18" above floor slide	2		7469	
Hose, 60	Pump to Generator Slide	2	Blue	2460	Inside generator tray
Travel Clamp	(two per slide, except the bed slide)	6		HWH	N/A

Measuring from inside of firewall, this is the end location of the hydraulic hoses where they attach to the slide mechanism.

Mounts to bracket on structure

99 / Drivers Side

187 / Drivers Side

7481

408 / Drivers Side

134998

408 / Passenger side

7469

Mounts to bracket on structure

135 / Passenger Side

220 / Passenger Side

7469

Inside generator tray

N/A

Options/ Notes

Note	Sync cylinder position	Rear

Revisions

1	Changed Pump to Room 2 hose length from 432" to 516".	12/3/07 KK
2	4-23-08, Updated to match EQ's new way of plumbing jacks.	

**43D Mandalay
EQUALIZER JACKS (FULLY AUTOMATIC)
STANDARD ON THIS UNIT**

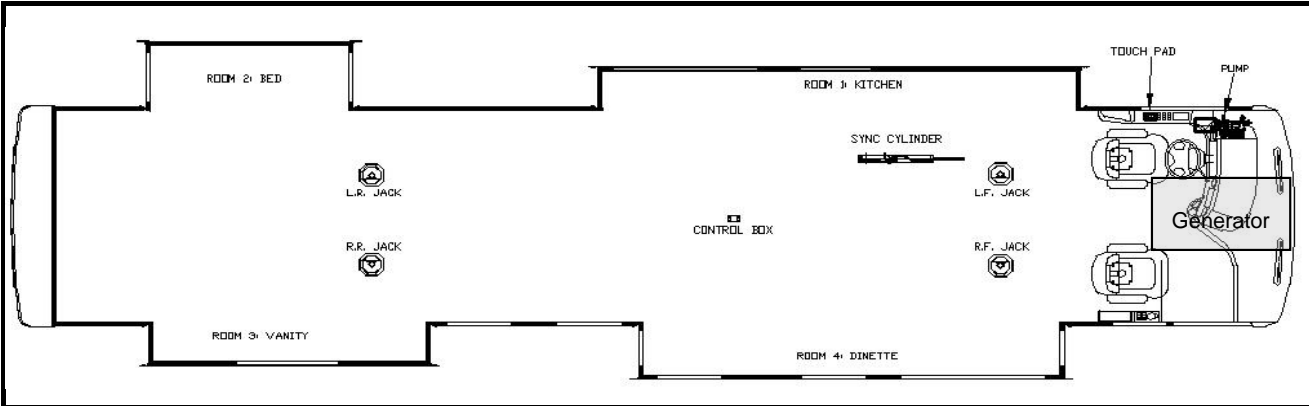

Notes:

- 1) Jacks mount to chassis brackets providing 8-9 inches of ground clearance with the air bags dumped.
- 2) Level sensor attaches to bottom of structure; on lower hat section flanges or square tube.
- 3) Hydraulic hose terminations for room #1, #3 & #4 require 90 degree swivel elbows.
- 4) Hoses marked w90 will have the 90 deg. Fitting shipped loose
- 5) All in floor slides to have automatic travel lock sensor

Item, Length	Description / Location	Qty	Color	Vendor PN	
Kit	(Items listed below)	1		8419	
Pump	9-Function, 4 Rooms, & Jacks	1		7464BR	
Jack	17,000 lbs, 18" Stroke	4		7134	
Touch Pad	Located to the left of the drivers seat	1		2318	
Control Box	Attached to bottom of structure	1		2730	
Sync Cylinder	Mounted behind LP tank	1		7397	
Sync Cylinder	Mounted behind LP tank	1		7511	
Hose, 144	Pump to Jack, Left Front	2	Brown	2467	
Hose, 480	Pump to Jack, Left Rear	2	Orange	2490	
Hose, 144	Pump to Jack, Right Front	2	White	2467	
Hose, 480	Pump to Jack, Right Rear	1	Yellow	2490	
Hose, 108	Left Rear Jack, Right Rear Jack	1	Yel/ Ora	2464	
Hose, 144	Pump to synchronizing cylinder	2	Green	2467	Mounts to bracket on structure
Hose w90, 204	Sync cylinder to front slide, Room 1	2	Green	2472	123 / Drivers Side
Hose w90, 204	Sync cylinder to rear slide, Room 1	2	Green	2472	210 / Drivers Side
Slide Unit	Room 1 - 18" above floor slide	2		7469	
Hose, 516	Pump to Room 2	2	Purple	2491	408 / Drivers Side
Slide Unit	Room 2 - 30" Bed slide (Lippert)	1		134998	
Hose w90, 480	Pump to Room 3	2	Grey	2490	408 / Passenger side
Slide Unit	Room 3 - 18" above floor slide	1		7469	
Hose, 144	Pump to synchronizing cylinder	2	Red	2467	Mounts to bracket on structure
Hose w90, 216	Sync cylinder to front slide, Room 4	2	Red	2473	123 / Passenger side
Hose w90, 216	Sync cylinder to rear slide, Room 4	2	Red	2473	210 / Passenger side
Slide Unit	Room 4 - 24" flush floor slide (angled)	2		7477	
Hose, 60	Pump to Generator Slide	2	Blue	2460	Inside generator tray
Travel Clamp	(two per slide, except the bed slide)	6		HWH	N/A

Measuring from inside of firewall, this is the end location of the hydraulic hoses where they attach to the slide mechanism.

Mounts to bracket on structure

123 / Drivers Side

210 / Drivers Side

408 / Drivers Side

408 / Passenger side

Mounts to bracket on structure

123 / Passenger side

210 / Passenger side

Inside generator tray

N/A

Options/ Notes

Note 1	Sync cylinder position	Front			

Revisions

1	4-23-08, Updated to match EQ's new way of plumbing jacks.
2	
3	
4	

**40G Mandalay
EQUALIZER JACKS (FULLY AUTOMATIC)
STANDARD ON THIS UNIT**

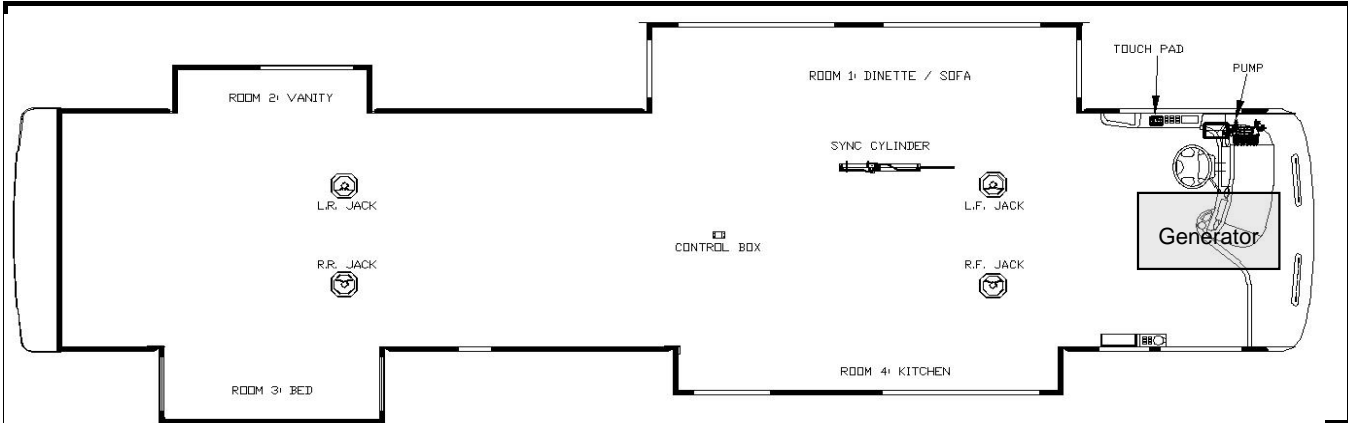

Notes:

- 1) Jacks mount to chassis brackets providing 8-9 inches of ground clearance with the air bags dumped.
- 2) Level sensor attaches to bottom of structure; on lower hat section flanges or square tube.
- 3) Hydraulic hose terminations for room #1, #3, & #4 require 90 degree swivel elbows.
- 4) Hoses marked w90 will have the 90 deg. Fitting shipped loose

Item, Length	Description / Location	Qty	Color	Vendor PN		
Kit	(Items listed below)	1		8359	Measuring from inside of firewall, this is the end location of the hydraulic hoses where they attach to the slide mechanism.	
Pump	9-Function, 4 Rooms, & Jacks	1		7464BR		
Jack	17,000 lbs, 18" Stroke	4		7134		
Touch Pad	Located to the left of the drivers seat	1		2318		
Control Box	Attached to bottom of structure	1		2730		
Sync Cylinder	Mounted behind LP tank	1		7387		
Hose, 144	Pump to Jack, Left Front	2	Brown	2467		
Hose, 480	Pump to Jack, Left Rear	2	Orange	2490		
Hose, 144	Pump to Jack, Right Front	2	White	2467		
Hose, 480	Pump to Jack, Right Rear	1	Yellow	2490		
Hose, 108	Left Rear Jack, Right Rear Jack	1	Yel/ Ora	2464		
Hose, 180	Pump to synchronizing cylinder	2	Green	2467		mounts to bracket on structure
Hose w90, 168	Sync cylinder to front slide, Room 1	2	Green	2469		99 / Drivers side
Hose w90, 168	Sync cylinder to rear slide, Room 1	2	Green	2469		201 / Drivers side
Slide Unit	Room 1 - 36" flush floor slide	2		7467		
Hose w90, 432	Pump to Room 2	2	Purple	2486	373 / Drivers Side	
Slide Unit	Room 2 - 18" above floor slide	1		7469		
Hose, 480	Pump to Room 3	2	Gray	2490	352 / Passenger Side	
Slide Unit	Room 2 - 30" Bed slide (Lippert)	1		134998		
Hose w90, 228	Pump to Room 4	2	Red	2474	153 / Passenger Side	
Slide Unit	Room 4 - 18" above floor slide	1		7469		
Hose, 60	Pump to Generator Slide	2	Blue	2460	Inside generator tray	
Travel Clamp	(two per slide, except the bed slide)	6		HWH	N/A	
Options						
Revisions						
12/6/2007	Added slide mechanism part numbers to chart.					
4/23/2008	Updated to match EQ's new way of plumbing jacks.					

**43A Mandalay
EQUALIZER JACKS (FULLY AUTOMATIC)
STANDARD ON THIS UNIT**

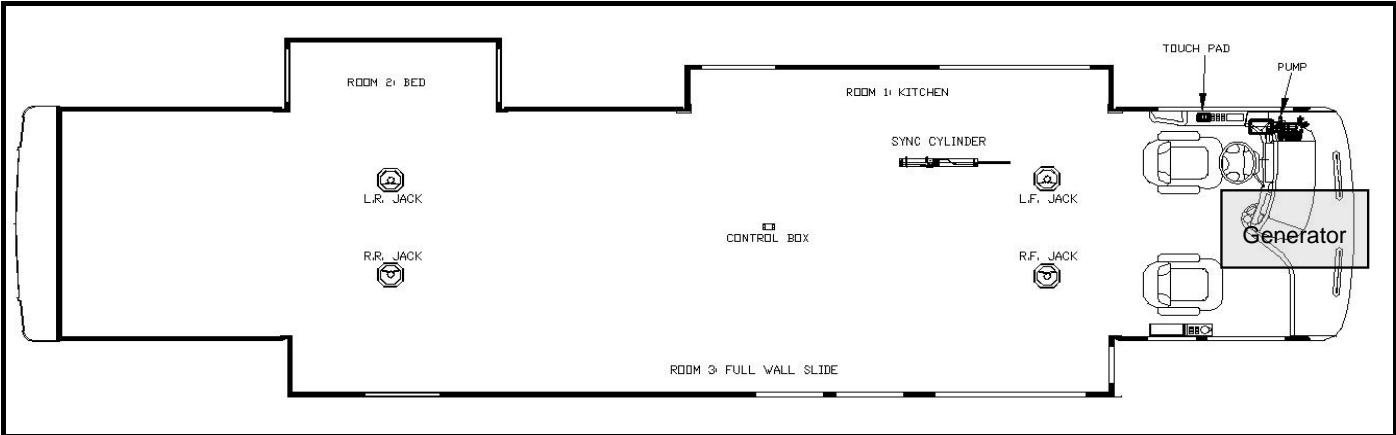

Notes:

- 1) Jacks mount to chassis brackets providing 8-9 inches of ground clearance with the air bags dumped.
- 2) Level sensor attaches to bottom of structure; on lower hat section flanges or square tube.
- 3) Hydraulic hose terminations for room #1 & #3 require 90 degree swivel elbows.
- 4) Hoses marked w90 will have the 90 deg. Fitting shipped loose
- 5) All in floor slides to have automatic travel lock sensor

Item, Length	Description / Location	Qty	Color	Vendor PN	
Kit	(Items listed below)	1		8360	
Pump	8-Function, 3 Rooms, & Jacks	1		7474BR	
Jack	17,000 lbs, 18" Stroke	4		7134	
Touch Pad	Located to the left of the drivers seat	1		2318	
Control Box	Attached to bottom of structure	1		2730	
Sync Cylinder	Mounted behind LP tank	1		7397	
Sync Cylinder	Mounted behind LP tank	1		7511	
Hose, 144	Pump to Jack, Left Front	2	Brown	2467	
Hose, 480	Pump to Jack, Left Rear	2	Orange	2490	
Hose, 144	Pump to Jack, Right Front	2	White	2467	
Hose, 480	Pump to Jack, Right Rear	1	Yellow	2490	
Hose, 108	Left Rear Jack, Right Rear Jack	1	Yel/ Ora	2464	
Hose, 180	Pump to synchronizing cylinder	2	Green	2470	Mounts to bracket on structure
Hose w90, 168	Sync cylinder to front slide, Room 1	2	Green	2469	105 / Drivers Side
Hose w90, 168	Sync cylinder to rear slide, Room 1	2	Green	2469	200 / Drivers Side
Slide Unit	Room 1 - 18" above floor slide	2		7469	
Hose w90, 516	Pump to Room 2	2	Purple	2491	408 / Drivers Side
Slide Unit	Room 2 - 30" Bed slide (Lippert)	1		134998	
Hose, 180	Pump to synchronizing cylinder	2	Grey	2470	Mounts to bracket on structure
Hose w90, 336	Sync cylinder to front slide, Room 3	2	Grey	2535	90 / Passenger side
Hose w90, 336	Sync cylinder to rear slide, Room 3	2	Grey	2535	378 / Passenger side
Slide Unit	Room 3 - 24" flush floor slide (angled)	2		7477	
Slide Unit	Room 3 - 24" flush floor slide (angled)	1		7384	Slave
Hose, 60	Pump to Generator Slide	2	Red	2460	Inside generator tray
Travel Clamp	(two per slide, except the bed slide)	4		HWH	N/A

Measuring from inside of firewall, this is the end location of the hydraulic hoses where they attach to the slide mechanism.

Options/ Notes

Note 1	Sync cylinder position				Front

Revisions

1	Corrected the bed slide Vendor Part No. Was 143960.	8-15-07	JS
2	Changed Pump to Room 2 hose length from 516" to 480".	12/3/07	KK
3	4-23-08, Updated to match EQ's new way of plumbing jacks.		
4	Changed Room 1 to two slides-Starts with unit 3629		

**43C Mandalay
EQUALIZER JACKS (FULLY AUTOMATIC)
STANDARD ON THIS UNIT**

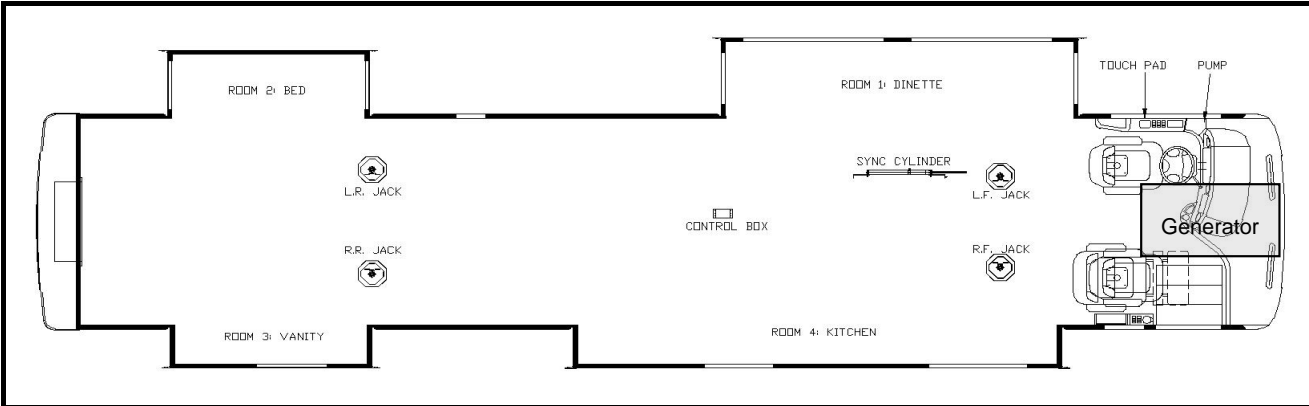

Notes:

- 1) Jacks mount to chassis brackets providing 8-9 inches of ground clearance with the air bags dumped.
- 2) Level sensor attaches to bottom of structure; on lower hat section flanges or square tube.
- 3) Hydraulic hose terminations for room #1, #3 & #4 require 90 degree swivel elbows.
- 4) Hoses marked w90 will have the 90 deg. Fitting shipped loose
- 5) All in floor slides to have automatic travel lock sensor

Item, Length	Description / Location	Qty	Color	Vendor PN	
Kit	(Items listed below)	1		8377	
Pump	9-Function, 4 Rooms, & Jacks	1		7464BR	
Jack	17,000 lbs, 18" Stroke	4		7134	
Touch Pad	Located to the left of the drivers seat	1		2318	
Control Box	Attached to bottom of structure	1		2730	
Sync Cylinder	Mounted behind LP tank, Room 1	1		7387	
Sync Cylinder	Mounted behind LP tank, Room 4	1		7511	
Hose, 144	Pump to Jack, Left Front	2	Brown	2467	
Hose, 480	Pump to Jack, Left Rear	2	Orange	2490	
Hose, 144	Pump to Jack, Right Front	2	White	2467	
Hose, 480	Pump to Jack, Right Rear	1	Yellow	2490	
Hose, 108	Left Rear Jack, Right Rear Jack	1	Yel/ Ora	2464	
Hose, 180	Pump to synchronizing cylinder	2	Green	2470	Mounts to bracket on structure
Hose w90, 168	Sync cylinder to front slide, Room 1	2	Green	2469	99 / Drivers Side
Hose w90, 168	Sync cylinder to rear slide, Room 1	2	Green	2469	187 / Drivers Side
Slide Unit	Room 1 - 36" flush floor slide (angled)	2		7481	
Hose, 516	Pump to Room 2	2	Purple	2491	408 / Drivers Side
Slide Unit	Room 2 - 30" Bed slide (Lippert)	1		134998	
Hose w90, 456	Pump to Room 3	2	Grey	2488	408 / Passenger side
Slide Unit	Room 3 - 18" above floor slide	1		7469	
Hose, 180	Pump to synchronizing cylinder	2	Red	2470	Mounts to bracket on structure
Hose w90, 228	Sync cylinder to rear slide, Room 4	2	Red	2474	135 / Passenger Side
Hose w90, 228	Sync cylinder to rear slide, Room 4	2	Red	2474	220 / Passenger Side
Slide Unit	Room 4 - 18" above floor slide	2		7469	
Hose, 60	Pump to Generator Slide	2	Blue	2460	Inside generator tray
Travel Clamp	(two per slide, except the bed slide)	6		HWH	N/A

Measuring from inside of firewall, this is the end location of the hydraulic hoses where they attach to the slide mechanism.

Mounts to bracket on structure

99 / Drivers Side

187 / Drivers Side

7481

408 / Drivers Side

134998

408 / Passenger side

7469

Mounts to bracket on structure

135 / Passenger Side

220 / Passenger Side

7469

Inside generator tray

N/A

Options/ Notes

Note 1	Sync cylinder position				Rear

Revisions

1	Changed Pump to Room 2 hose length from 432" to 516".	12/3/07	KK
2	4-23-08, Updated to match EQ's new way of plumbing jacks.		

**43D Mandalay
EQUALIZER JACKS (FULLY AUTOMATIC)
STANDARD ON THIS UNIT**

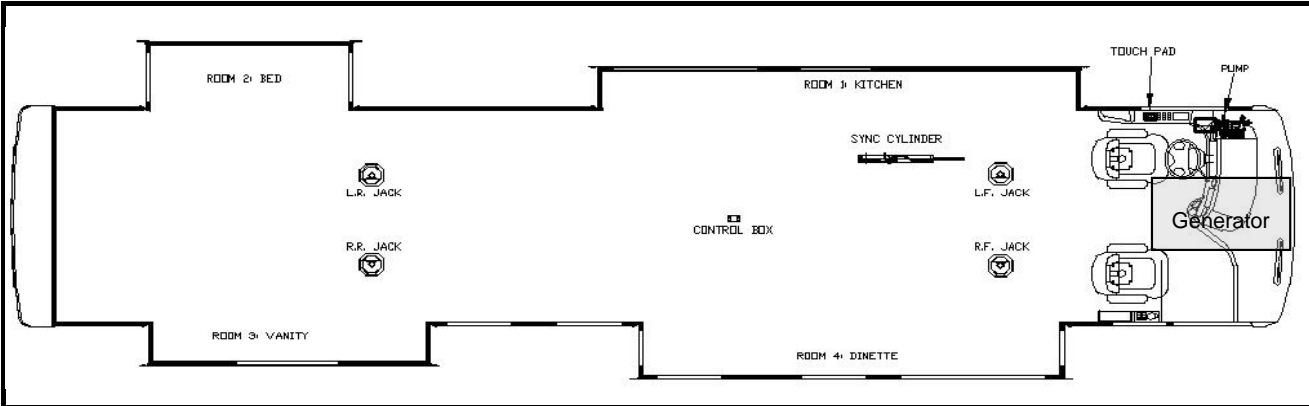

Notes:

- 1) Jacks mount to chassis brackets providing 8-9 inches of ground clearance with the air bags dumped.
- 2) Level sensor attaches to bottom of structure; on lower hat section flanges or square tube.
- 3) Hydraulic hose terminations for room #1, #3 & #4 require 90 degree swivel elbows.
- 4) Hoses marked w90 will have the 90 deg. Fitting shipped loose
- 5) All in floor slides to have automatic travel lock sensor

Item, Length	Description / Location	Qty	Color	Vendor PN	
Kit	(Items listed below)	1		8419	
Pump	9-Function, 4 Rooms, & Jacks	1		7464BR	
Jack	17,000 lbs, 18" Stroke	4		7134	
Touch Pad	Located to the left of the drivers seat	1		2318	
Control Box	Attached to bottom of structure	1		2730	
Sync Cylinder	Mounted behind LP tank	1		7397	
Sync Cylinder	Mounted behind LP tank	1		7511	
Hose, 144	Pump to Jack, Left Front	2	Brown	2467	
Hose, 480	Pump to Jack, Left Rear	2	Orange	2490	
Hose, 144	Pump to Jack, Right Front	2	White	2467	
Hose, 480	Pump to Jack, Right Rear	1	Yellow	2490	
Hose, 108	Left Rear Jack, Right Rear Jack	1	Yel/ Ora	2464	
Hose, 144	Pump to synchronizing cylinder	2	Green	2467	Mounts to bracket on structure
Hose w90, 204	Sync cylinder to front slide, Room 1	2	Green	2472	123 / Drivers Side
Hose w90, 204	Sync cylinder to rear slide, Room 1	2	Green	2472	210 / Drivers Side
Slide Unit	Room 1 - 18" above floor slide	2		7469	
Hose, 516	Pump to Room 2	2	Purple	2491	408 / Drivers Side
Slide Unit	Room 2 - 30" Bed slide (Lippert)	1		134998	
Hose w90, 480	Pump to Room 3	2	Grey	2490	408 / Passenger side
Slide Unit	Room 3 - 18" above floor slide	1		7469	
Hose, 144	Pump to synchronizing cylinder	2	Red	2467	Mounts to bracket on structure
Hose w90, 216	Sync cylinder to front slide, Room 4	2	Red	2473	123 / Passenger side
Hose w90, 216	Sync cylinder to rear slide, Room 4	2	Red	2473	210 / Passenger side
Slide Unit	Room 4 - 24" flush floor slide (angled)	2		7477	
Hose, 60	Pump to Generator Slide	2	Blue	2460	Inside generator tray
Travel Clamp	(two per slide, except the bed slide)	6		HWH	N/A

Measuring from inside of firewall, this is the end location of the hydraulic hoses where they attach to the slide mechanism.

Mounts to bracket on structure

123 / Drivers Side

210 / Drivers Side

408 / Drivers Side

408 / Passenger side

Mounts to bracket on structure

123 / Passenger side

210 / Passenger side

Inside generator tray

N/A

Options/ Notes

Note 1	Sync cylinder position				Front

Revisions

1	4-23-08, Updated to match EQ's new way of plumbing jacks.
2	
3	
4	

**32A HURRICANE (19.5) TIRES
EQUALIZER JACKS (FULLY AUTOMATIC)
OPTIONAL ON THIS UNIT**

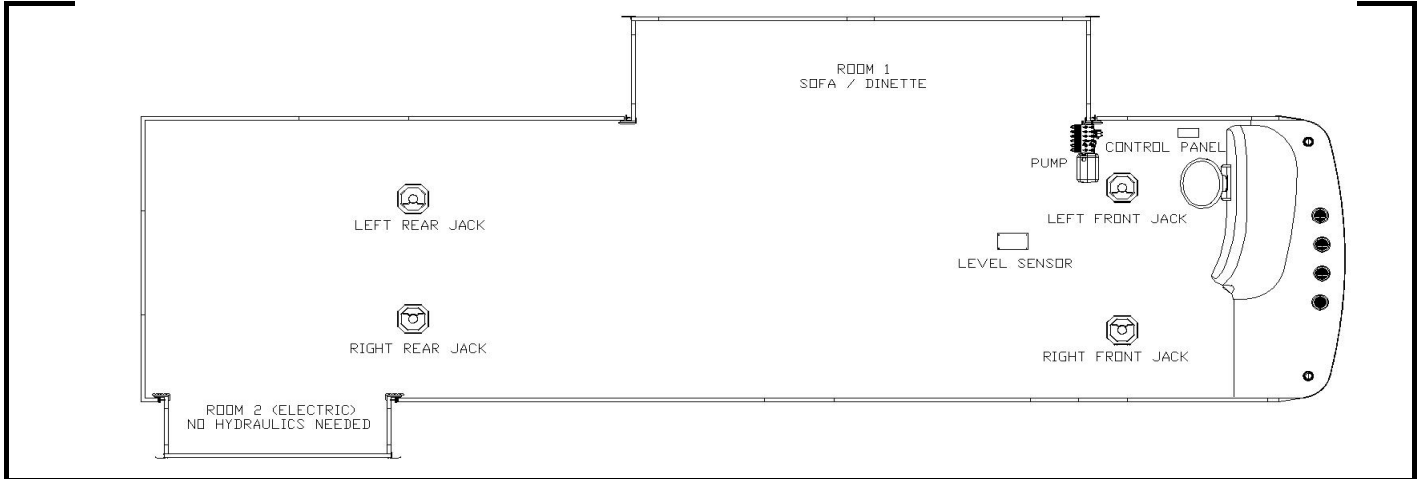

Notes:

- 1) Jacks mount in two different locations on bracket depending on tire size of chassis.
 - a) 19.5 Tires: Top hole in jack to top hole in bracket. Use 4 bolts in welded area of bracket.
 - b) 22.5 Tires: Top hole in jack to second hole in bracket. Use 6 bolts, 4 in welded area of bracket & 2 below welded area.

Item, Length	Description / Location	Qty	Color	Vendor PN	
Kit	(Items listed below)	1		8270	
Pump	5-Function, 1 Room, Jacks	1		7242BR	
Jack	12,000 lbs, 16" Stroke	4		7214	
Touch Pad	Located to the left of the drivers seat	1		3012	
Control Box	Attached to bottom of structure	1		2730	
Sync Cylinder	Mounted behind pump compartment	N/A		N/A	
Hose, 72	Pump to Jack, Left Front	2	Brown	2461	
Hose, 288	Pump to Jack, Left Rear	2	Orange	2478	
Hose, 120	Pump to Jack, Right Front	1	White	2465	
Hose, 336	Pump to Jack, Right Rear	1	Yellow	2535	
Hose, 96	Left Front Jack, Right Front Jack	1	Whi/Brn.	2463	N/A
Hose, 96	Left Rear Jack, Right Rear Jack	1	Yel/Ora.	2463	N/A
Hose, 120	Pump to Room 1	2	Green	2465	144 / Drivers Side (COIL AT PUMP)
Slide Unit	Room 1-36" Above floor slide (bolt-in)	1		7164B	
Hose, N/A	Pump to Room 2	N/A	Purple	N/A	N/A
Slide Unit	Room 2				
Hose, N/A	Pump to Room 3	N/A	Gray	N/A	N/A
Slide Unit	Room 3				
Hose, N/A	Pump to Room 4	N/A	Red	N/A	N/A
Slide Unit	Room 4				
Travel Clamp	Two per Slide	N/A		HWH	N/A

Measuring from front of bumper, this is the end location of the hydraulic hoses where they attach to the slide mechanism.

Options

Revisions

1	Make jacks standard per ECN 6842 (11/9/09)
2	Update pump location per ECN 6935 (4-29-10)

**34B HURRICANE (19.5) TIRES
EQUALIZER JACKS (FULLY AUTOMATIC)
STANDARD ON THIS UNIT**

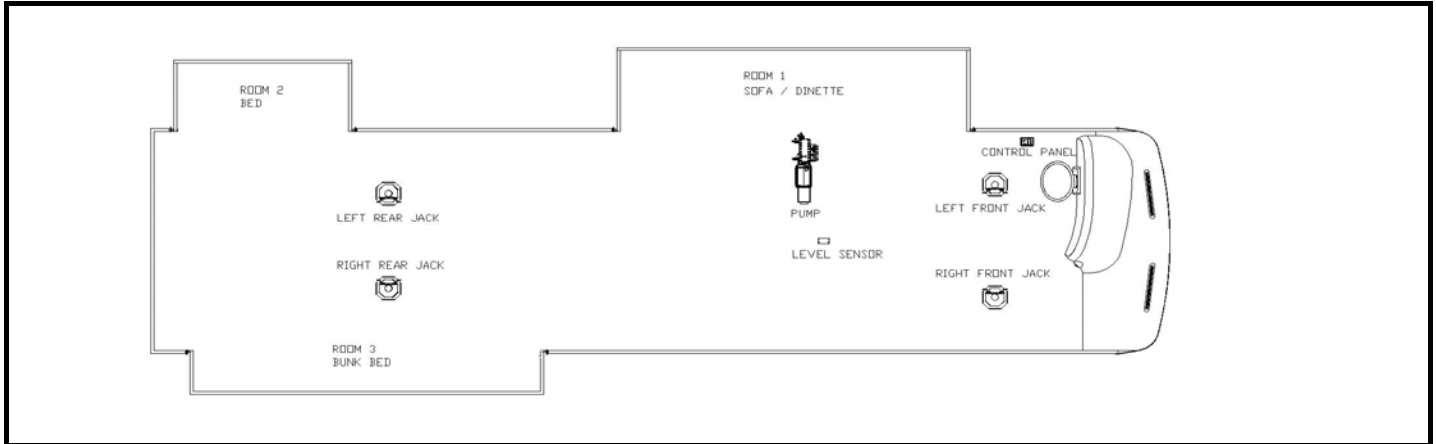

Notes:

- 1) Jacks mount in two different locations on bracket depending on tire size of chassis.
 - a) 19.5 Tires: Top hole in jack to top hole in bracket. Use 4 bolts in welded area of bracket.
 - b) 22.5 Tires: Top hole in jack to second hole in bracket. Use 6 bolts, 4 in welded area of bracket & 2 below welded area.

Item, Length	Description / Location	Qty	Color	Vendor PN		
Kit	(Items listed below)	1		8323	Measuring from inside of firewall, this is the end location of the hydraulic hoses where they attach to the slide mechanism.	
Pump	7-Function, 3 Rooms, Jacks	1		7301BR		
Jack	12,000 lbs, 16" Stroke	4		7214		
Touch Pad	Located to the left of the drivers seat	1		3012		
Control Box	Attached to bottom of structure	1		2730		
Flow Divider	Mounted inside pump compartment	N/A		N/A		
Hose, 144	Pump to Jack, Left Front	2	Brown	2467		
Hose, 240	Pump to Jack, Left Rear	2	Orange	2475		
Hose, 168	Pump to Jack, Right Front	2	White	2469		
Hose, 264	Pump to Jack, Right Rear	1	Yellow	2476		
Hose, 96	Left Rear Jack, Right Rear Jack	1	Yel/Ora.	2463		
Hose, 36	Pump to Room 1	2	Green	2458		127 / Drivers Side
Slide Unit	Room 1-36" Above Floor Slide	1		7164		
Hose, 384	Pump to Room 2	2	Purple	2482	347 / Drivers Side	
Slide Unit	Room 2-30" Bed Slide(Lipper)	1		134998		
Hose w90, 384	Pump to Room 3	2	Gray	2482	307 / Passenger Side	
Slide Unit	Room 3-18" Above floor slide	1		7135		
Hose, N/A	Pump to Room 4	N/A	Red	N/A	N/A	
Travel Clamp	Two per Slide	N/A		N/A	N/A	

Options

Revisions

9/1/2006	Add 34S to 34B chart
2	Update per Equalizer Specs

**34U HURRICANE (22.5) TIRES
EQUALIZER JACKS (FULLY AUTOMATIC)
STANDARD ON THIS UNIT**

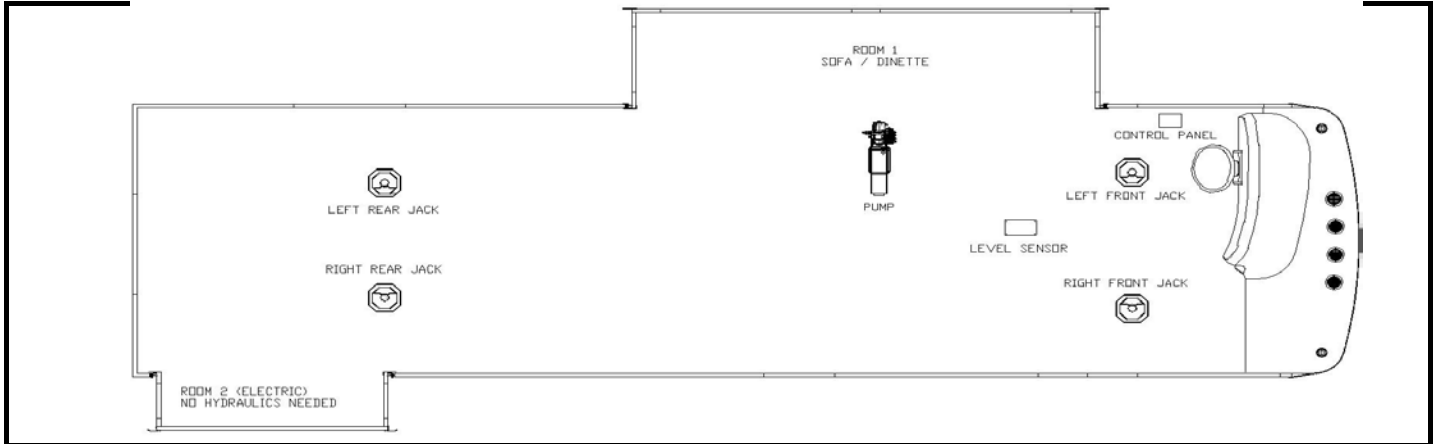

Notes:

- 1) Jacks mount in two different locations on bracket depending on tire size of chassis.
 - a) 19.5 Tires: Top hole in jack to top hole in bracket. Use 4 bolts in welded area of bracket.
 - b) 22.5 Tires: Top hole in jack to second hole in bracket. Use 6 bolts, 4 in welded area of bracket & 2 below welded area.

Item, Length	Description / Location	Qty	Color	Vendor PN		
Kit	(Items listed below)	1		8466	Measuring from inside of firewall, this is the end location of the hydraulic hoses where they attach to the slide mechanism.	
Pump	6-Function, 2 Rooms & Jacks	1		7243BR		
Jack	12,000 lbs, 16" Stroke	4		7214		
Touch Pad	Located to the left of the drivers seat	1		3012		
Control Box	Attached to bottom of structure	1		2730		
Sync Cylinder	Mounted behind pump compartment	N/A		N/A		
Hose, 144	Pump to Jack, Left Front	2	Brown	2467		
Hose, 240	Pump to Jack, Left Rear	2	Orange	2475		
Hose, 168	Pump to Jack, Right Front	2	White	2469		
Hose, 264	Pump to Jack, Right Rear	1	Yellow	2476		
Hose, 96	Left Rear Jack, Right Rear Jack	1	Yel/Ora.	2463		Inside pump compartment
Hose, 36	Pump to Room 1	2	Green	2458		127 / Drivers Side
Slide Unit	Room 1-36" Above Floor Slide	1		7164		N/A
Hose, 384	Pump to Room 2	2	Purple	2482		347 / Passenger Side
Slide Unit	Room 2-30" Bed Slide(Lipper)	1		134998		
Hose, N/A	Pump to Room 3		Gray			
Slide Unit	Room 3-				N/A	
Hose, N/A	Pump to Room 4	N/A	Red	N/A	N/A	
Travel Clamp	Two per Slide	N/A		N/A	N/A	

Options

Revisions

**34B HURRICANE (19.5) TIRES
EQUALIZER JACKS (FULLY AUTOMATIC)
STANDARD ON THIS UNIT**

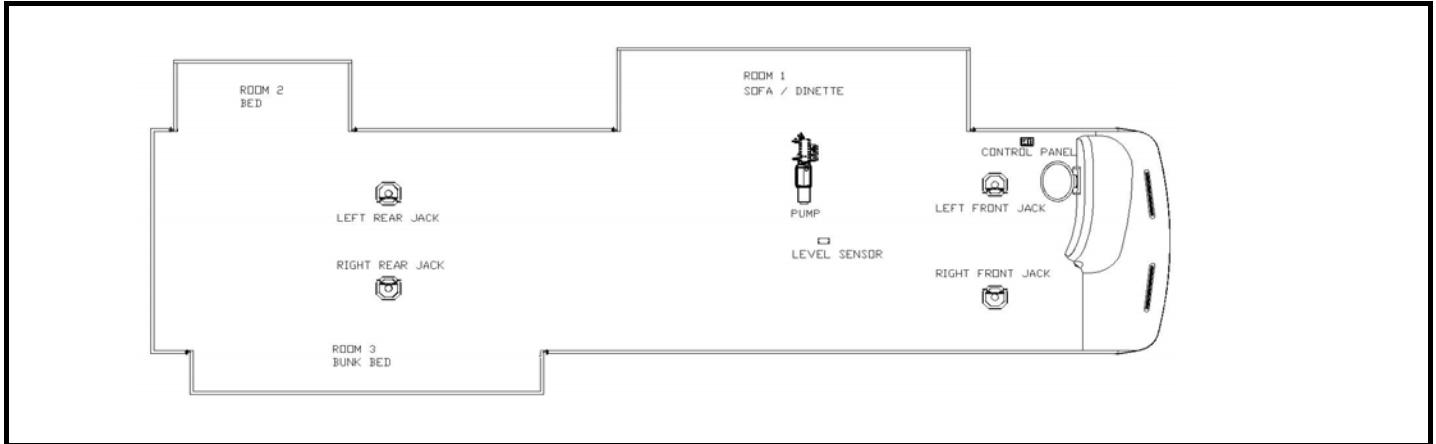

Notes:

- 1) Jacks mount in two different locations on bracket depending on tire size of chassis.
 - a) 19.5 Tires: Top hole in jack to top hole in bracket. Use 4 bolts in welded area of bracket.
 - b) 22.5 Tires: Top hole in jack to second hole in bracket. Use 6 bolts, 4 in welded area of bracket & 2 below welded area.

Item, Length	Description / Location	Qty	Color	Vendor PN		
Kit	(Items listed below)	1		8323	Measuring from inside of firewall, this is the end location of the hydraulic hoses where they attach to the slide mechanism.	
Pump	7-Function, 3 Rooms, Jacks	1		7301BR		
Jack	12,000 lbs, 16" Stroke	4		7214		
Touch Pad	Located to the left of the drivers seat	1		2318		
Control Box	Attached to bottom of structure	1		2730		
Flow Divider	Mounted inside pump compartment	N/A		N/A		
Hose, 144	Pump to Jack, Left Front	2	Brown	2467		
Hose, 240	Pump to Jack, Left Rear	2	Orange	2475		
Hose, 168	Pump to Jack, Right Front	2	White	2469		
Hose, 264	Pump to Jack, Right Rear	1	Yellow	2476		
Hose, 96	Left Rear Jack, Right Rear Jack	1	Yel/Ora.	2463		
Hose, 36	Pump to Room 1	2	Green	2458		127 / Drivers Side
Slide Unit	Room 1-36" Above Floor Slide	1		7164		
Hose, 384	Pump to Room 2	2	Purple	2482	347 / Drivers Side	
Slide Unit	Room 2-30" Bed Slide(Lipper)	1		134998		
Hose w90, 384	Pump to Room 3	2	Gray	2482	307 / Passenger Side	
Slide Unit	Room 3-18" Above floor slide	1		7135		
Hose, N/A	Pump to Room 4	N/A	Red	N/A	N/A	
Travel Clamp	Two per Slide	N/A		N/A	N/A	

Options					

Revisions	
9/1/2006	Add 34S to 34B chart
2	Update per Equalizer Specs

**34U HURRICANE (22.5) TIRES
EQUALIZER JACKS (FULLY AUTOMATIC)
STANDARD ON THIS UNIT**

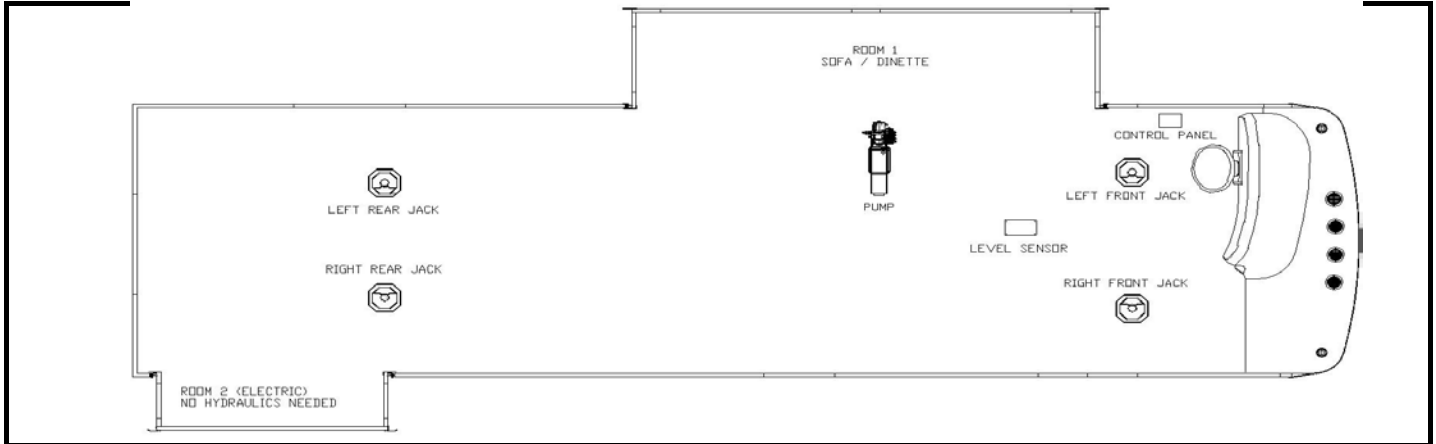

Notes:

- 1) Jacks mount in two different locations on bracket depending on tire size of chassis.
 - a) 19.5 Tires: Top hole in jack to top hole in bracket. Use 4 bolts in welded area of bracket.
 - b) 22.5 Tires: Top hole in jack to second hole in bracket. Use 6 bolts, 4 in welded area of bracket & 2 below welded area.

Item, Length	Description / Location	Qty	Color	Vendor PN		
Kit	(Items listed below)	1		8466	Measuring from inside of firewall, this is the end location of the hydraulic hoses where they attach to the slide mechanism.	
Pump	6-Function, 2 Rooms & Jacks	1		7243BR		
Jack	12,000 lbs, 16" Stroke	4		7214		
Touch Pad	Located to the left of the drivers seat	1		2318		
Control Box	Attached to bottom of structure	1		2730		
Sync Cylinder	Mounted behind pump compartment	N/A		N/A		
Hose, 144	Pump to Jack, Left Front	2	Brown	2467		
Hose, 240	Pump to Jack, Left Rear	2	Orange	2475		
Hose, 168	Pump to Jack, Right Front	2	White	2469		
Hose, 264	Pump to Jack, Right Rear	1	Yellow	2476		
Hose, 96	Left Rear Jack, Right Rear Jack	1	Yel/Ora.	2463		Inside pump compartment
Hose, 36	Pump to Room 1	2	Green	2458		127 / Drivers Side
Slide Unit	Room 1-36" Above Floor Slide	1		7164		N/A
Hose, 384	Pump to Room 2	2	Purple	2482		347 / Passenger Side
Slide Unit	Room 2-30" Bed Slide(Lipper)	1		134998		
Hose, N/A	Pump to Room 3		Gray			
Slide Unit	Room 3-				N/A	
Hose, N/A	Pump to Room 4	N/A	Red	N/A	N/A	
Travel Clamp	Two per Slide	N/A		N/A	N/A	

Options

Revisions

**32A WINDSPORT (19.5) TIRES
EQUALIZER JACKS (FULLY AUTOMATIC)
OPTIONAL ON THIS UNIT**

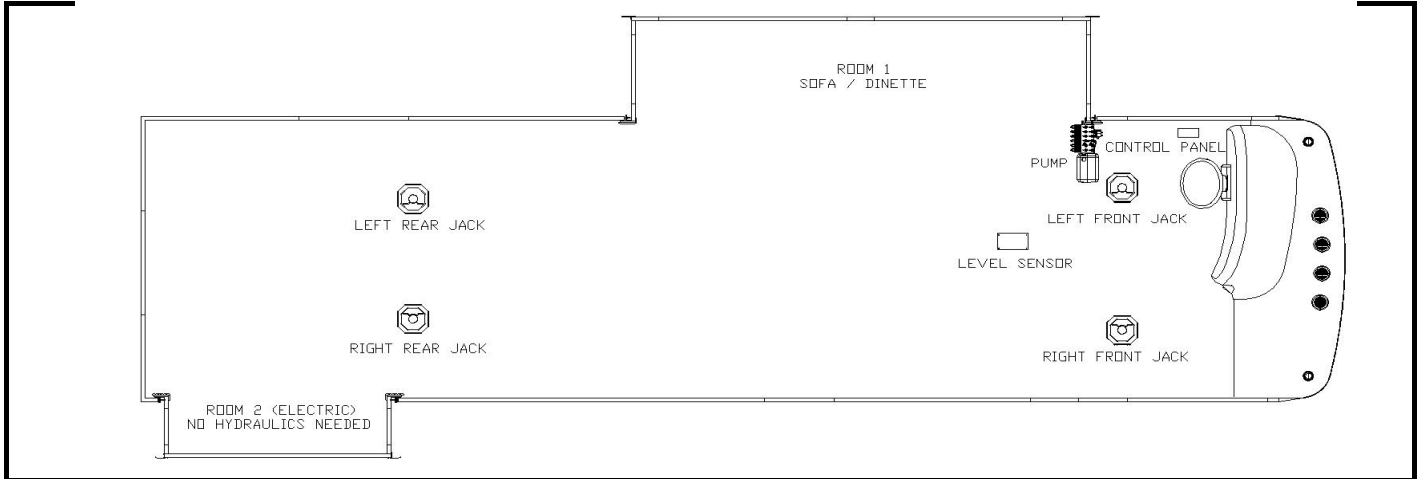

Notes:

- 1) Jacks mount in two different locations on bracket depending on tire size of chassis.
 - a) 19.5 Tires: Top hole in jack to top hole in bracket. Use 4 bolts in welded area of bracket.
 - b) 22.5 Tires: Top hole in jack to second hole in bracket. Use 6 bolts, 4 in welded area of bracket & 2 below welded area.

Item, Length	Description / Location	Qty	Color	Vendor PN		
Kit	(Items listed below)	1		8270		
Pump	5-Function, 1 Room, Jacks	1		7242BR		
Jack	12,000 lbs, 16" Stroke	4		7214		
Touch Pad	Located to the left of the drivers seat	1		3012		
Control Box	Attached to bottom of structure	1		2730		
Sync Cylinder	Mounted behind pump compartment	N/A		N/A		
Hose, 72	Pump to Jack, Left Front	2	Brown	2461	Measuring from front of bumper, this is the end location of the hydraulic hoses where they attach to the slide mechanism.	
Hose, 288	Pump to Jack, Left Rear	2	Orange	2478		
Hose, 120	Pump to Jack, Right Front	1	White	2465		
Hose, 336	Pump to Jack, Right Rear	1	Yellow	2535		
Hose, 96	Left Front Jack, Right Front Jack	1	Whi/Brn.	2463		N/A
Hose, 96	Left Rear Jack, Right Rear Jack	1	Yel/Ora.	2463		N/A
Hose, 120	Pump to Room 1	2	Green	2465		144 / Drivers Side (COIL AT PUMP)
Slide Unit	Room 1-36" Above floor slide (bolt-in)	1		7164B		
Hose, N/A	Pump to Room 2	N/A	Purple	N/A		N/A
Slide Unit	Room 2					
Hose, N/A	Pump to Room 3	N/A	Gray	N/A	N/A	
Slide Unit	Room 3					
Hose, N/A	Pump to Room 4	N/A	Red	N/A	N/A	
Slide Unit	Room 4					
Travel Clamp	Two per Slide	N/A		HWH	N/A	

Options

Revisions

1	Make jacks standard per ECN 6842 (11/9/09)
2	Update pump location per ECN 6935 (4-29-10)

**32V WINDSPORT
(22.5) TIRES
EQUALIZER JACKS (FULLY AUTOMATIC)
STANDARD ON THIS UNIT**

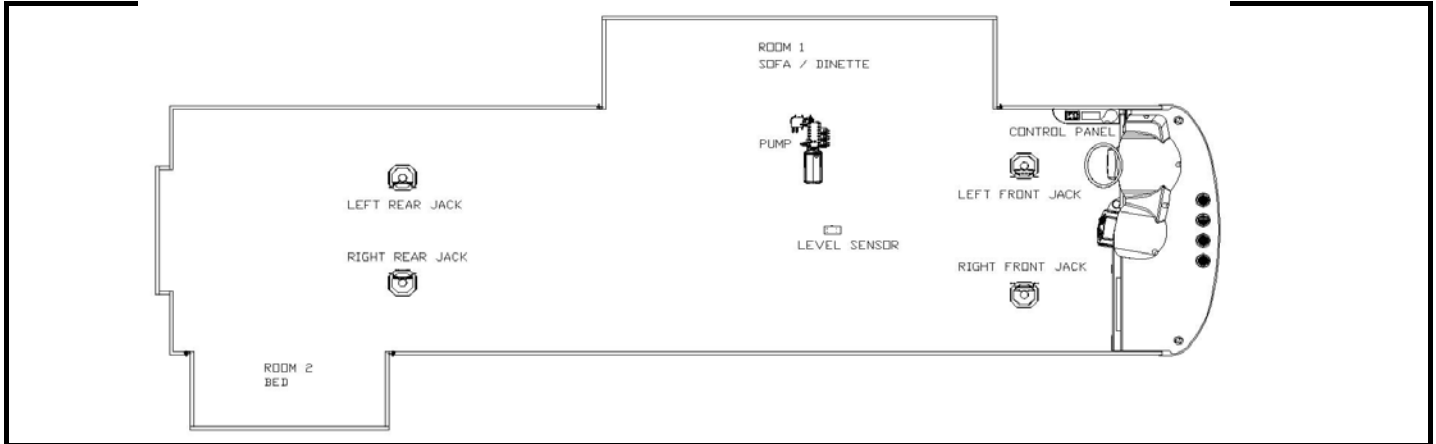

Notes:

- 1) Jacks mount in two different locations on bracket depending on tire size of chassis.
 - a) 19.5 Tires: Top hole in jack to top hole in bracket. Use 4 bolts in welded area of bracket.
 - b) 22.5 Tires: Top hole in jack to second hole in bracket. Use 6 bolts, 4 in welded area of bracket & 2 below welded area.

Item, Length	Description / Location	Qty	Color	Vendor PN	
Kit	(Items listed below)	1		8308	Measuring from inside of firewall, this is the end location of the hydraulic hoses where they attach to the slide mechanism.
Pump	6-Function, 2 Rooms & Jacks	1		7243BR	
Jack	12,000 lbs, 16" Stroke	4		7214	
Touch Pad	Located to the left of the drivers seat	1		2318	
Control Box	Attached to bottom of structure	1		2730	
Sync Cylinder	Mounted behind pump compartment	N/A		N/A	
Hose, 144	Pump to Jack, Left Front	2	Brown	2467	
Hose, 240	Pump to Jack, Left Rear	2	Orange	2475	
Hose, 192	Pump to Jack, Right Front	1	White	2471	
Hose, 288	Pump to Jack, Right Rear	1	Yellow	2478	
Hose, 96	Left Front Jack, Right Front Jack	1	Whi/Brn	2463	
Hose, 96	Left Rear Jack, Right Rear Jack	1	Yel/Ora.	2463	
Hose, 36	Pump to Room 1	2	Green	2458	127 / Drivers Side
Slide Unit	Room 1-36" Above floor slide	1		7164	
Hose, 384	Pump to Room 2	2	Purple	2482	310 / Passenger Side
Slide Unit	Room 2-30" Lippert Bed Slide	1		134998	
Hose, N/A	Pump to Room 3	N/A	Gray	N/A	N/A
Slide Unit					
Hose, N/A	Pump to Room 4	N/A	Red	N/A	N/A
Slide Unit					
Travel Clamp	Two per Slide	N/A		HWH	N/A

Options

Revisions

1	New model per ECN 6638 (8-25-09)

**34B WINDSPORT (22.5) TIRES
EQUALIZER JACKS (FULLY AUTOMATIC)
STANDARD ON THIS UNIT**

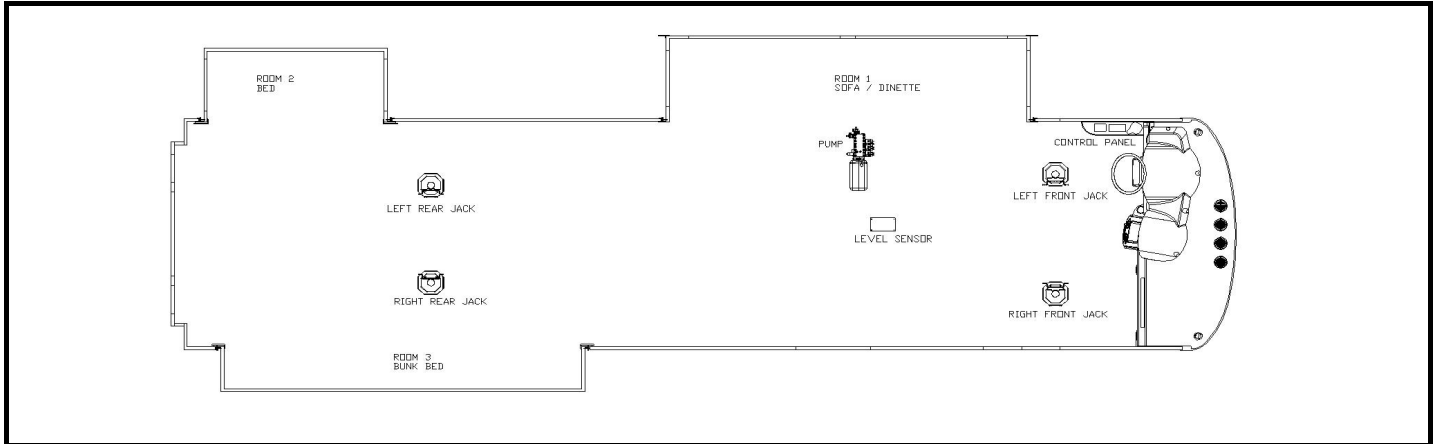

Notes:

- 1) Jacks mount in two different locations on bracket depending on tire size of chassis.
 - a) 19.5 Tires: Top hole in jack to top hole in bracket. Use 4 bolts in welded area of bracket.
 - b) 22.5 Tires: Top hole in jack to second hole in bracket. Use 6 bolts, 4 in welded area of bracket & 2 below welded area.

Item, Length	Description / Location	Qty	Color	Vendor PN	
Kit	(Items listed below)	1		8323	
Pump	7-Function, 3 Rooms & Jacks	1		7301BR	
Jack	12,000 lbs, 16" Stroke	4		7214	
Touch Pad	Located to the left of the drivers seat	1		2318	
Control Box	Attached to bottom of structure	1		2730	
Sync Cylinder	Mounted behind pump compartment	N/A		N/A	
Hose, 144	Pump to Jack, Left Front	2	Brown	2467	Measuring from inside of firewall, this is the end location of the hydraulic hoses where they attach to the slide mechanism.
Hose, 240	Pump to Jack, Left Rear	2	Orange	2475	
Hose, 168	Pump to Jack, Right Front	2	White	2469	
Hose, 264	Pump to Jack, Right Rear	1	Yellow	2476	
Hose, 96	Left Rear Jack, Right Rear Jack	1	Yel/Ora	2463	
Hose, 36	Pump to Room 1	2	Green	2458	127 / Drivers Side
Slide Unit	Room 1-36" Above Floor Slide	1		7164	
Hose, 384	Pump to Room 2	2	Purple	2482	347 / Drivers Side
Slide Unit	Room 2-30" Bed Slide(Lipper)	1		134998	
Hose w90, 384	Pump to Room 3	2	Gray	2482	307 / Passenger Side
Slide Unit	Room 3-18" Above floor slide	1		7135	
Hose, N/A	Pump to Room 4	N/A	Red	N/A	N/A
Travel Clamp	Two per Slide	N/A		N/A	N/A

Options					

Revisions	
1	Update per Equalizer Specs
2	Add Magellan to chart, same as Windsport per ECN 4582.
3	Cease building Magellan, omit name from header per ECN 6657 (8-25-09)

**34U WINDSPORT
(22.5) TIRES
EQUALIZER JACKS (FULLY AUTOMATIC)
STANDARD ON THIS UNIT**

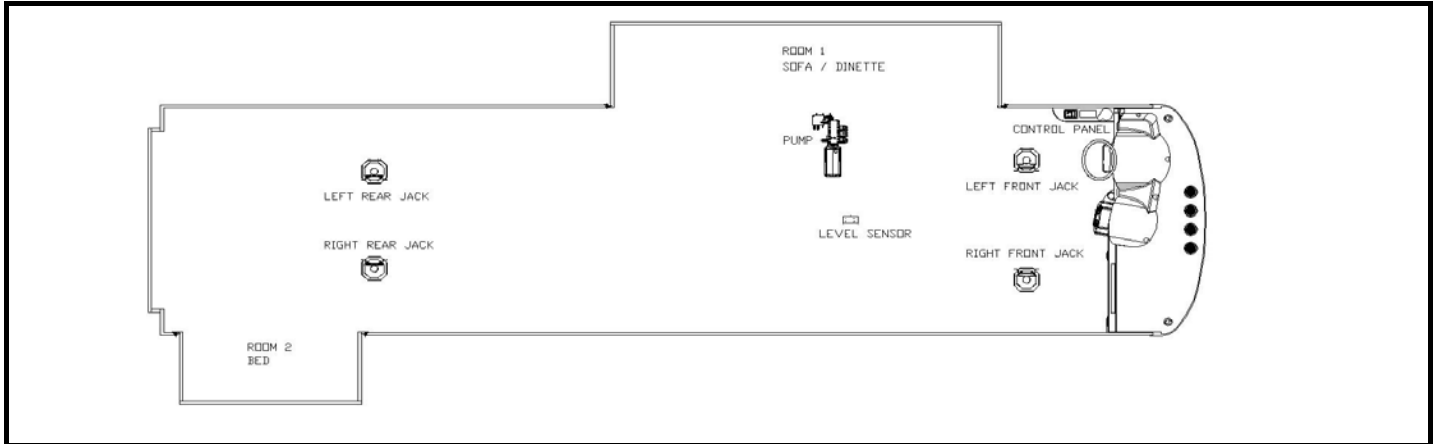

Notes:

- 1) Jacks mount in two different locations on bracket depending on tire size of chassis.
 - a) 19.5 Tires: Top hole in jack to top hole in bracket. Use 4 bolts in welded area of bracket.
 - b) 22.5 Tires: Top hole in jack to second hole in bracket. Use 6 bolts, 4 in welded area of bracket & 2 below welded area.

Item, Length	Description / Location	Qty	Color	Vendor PN	
Kit	(Items listed below)	1		8466	Measuring from inside of firewall, this is the end location of the hydraulic hoses where they attach to the slide mechanism.
Pump	6-Function, 2 Rooms & Jacks	1		7243BR	
Jack	12,000 lbs, 16" Stroke	4		7214	
Touch Pad	Located to the left of the drivers seat	1		2318	
Control Box	Attached to bottom of structure	1		2730	
Sync Cylinder	Mounted behind pump compartment	N/A		N/A	
Hose, 144	Pump to Jack, Left Front	2	Brown	2467	
Hose, 240	Pump to Jack, Left Rear	2	Orange	2475	
Hose 168	Pump to Jack, Right Front	2	White	2469	
Hose, 264	Pump to Jack, Right Rear	1	Yellow	2476	
Hose, 96	Left Rear Jack, Right Rear Jack	1	Yel/Ora.	2463	
Hose, 36	Pump to Room 1	2	Green	2458	127 / Drivers Side
Slide Unit	Room 1-36" Above Floor Slide	1		7164	
Hose, 384	Pump to Room 2	2	Purple	2482	347 / Passenger Side
Slide Unit	Room 2-30" Bed Slide (Lippert)	1		134998	
Hose, N/A	Pump to Room 3	N/A	Gray	N/A	N/A
Slide Unit					
Hose, N/A	Pump to Room 4	N/A	Red	N/A	N/A
Slide Unit					
Travel Clamp	Two per Slide	N/A		N/A	N/A
Options					
Revisions					
1	Added Kit #, Revised per Equalizer changes (added left rear jack to right rear jack hose - vendor PN 2463)				
2	Cease building Magellan, omit name from header per ECN 6657 (8-25-09)				

**36F WINDSPORT (22.5) TIRES
EQUALIZER JACKS (FULLY AUTOMATIC)
STANDARD ON THIS UNIT**

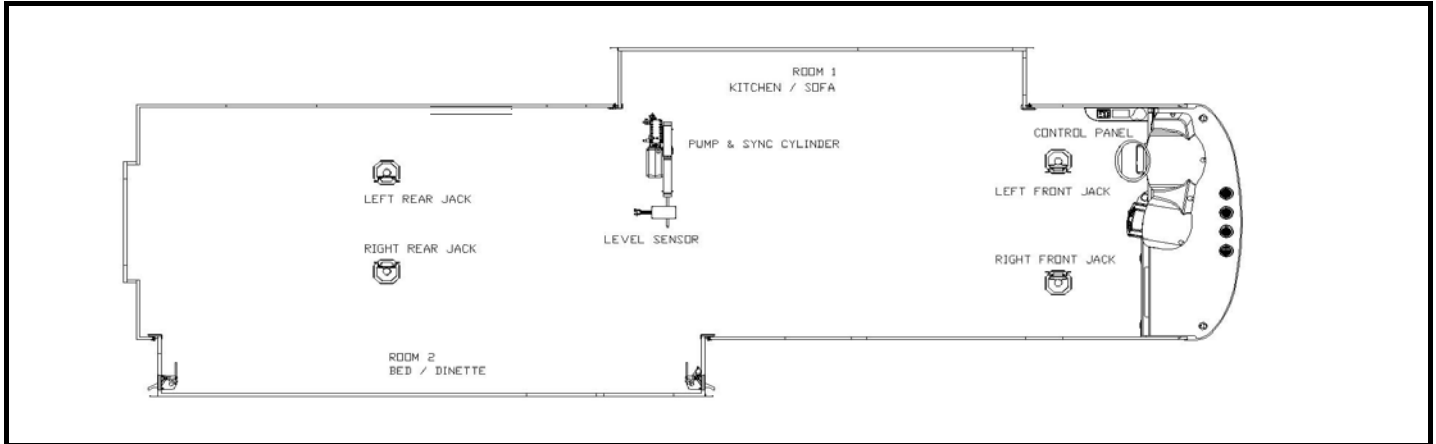

Notes:

- 1) Jacks mount in two different locations on bracket depending on tire size of chassis.
 - a) 19.5 Tires: Top hole in jack to top hole in bracket. Use 4 bolts in welded area of bracket.
 - b) 22.5 Tires: Top hole in jack to second hole in bracket. Use 6 bolts, 4 in welded area of bracket & 2 below welded area.
 - c) Hydraulic hose terminations for both rooms require 90 degree swivel elbows.

Item, Length	Description / Location	Qty	Color	Vendor PN	
Kit	(Items listed below)	1		8366	
Pump	6-Function, 2 Rooms & Jacks	1		7243BR	
Jack	12,000 lbs, 16" Stroke	4		7214	
Touch Pad	Located to the left of the drivers seat	1		2318	
Level Controller	Attached to bottom of structure	1		2730	
Sync Cylinder	Mounted inside pump compartment	1		7397	
Hose, 240	Pump to Jack, Left Front	2	Brown	2475	
Hose, 168	Pump to Jack, Left Rear	2	Orange	2469	
Hose, 264	Pump to Jack, Right Front	1	White	2476	
Hose, 216	Pump to Jack, Right Rear	1	Yellow	2473	
Hose, 96	Left Front Jack, Right Front Jack	1	Whi/Brn	2463	
Hose, 96	Left Rear Jack, Right Rear Jack	1	Yel/Ora.	2463	
Hose w/90, 120	Pump to Room 1	2	Green	2465	135 / Drivers Side
Slide Unit	Room 1 - 24" above floor slide	1		7369	
Hose, 36	Pump to sync cylinder	2	Purple	2458	Inside pump compartment
Hose w/90, 240	Sync cylinder to front slide, Room 2	2	Purple	2475	225 / Passenger Side
Hose w/90, 240	Sync cylinder to rear slide, Room 2	2	Purple	2475	371 / Passenger Side
Slide Unit	Room 2 - 24" flush floor slide (angled)	2		7388	
Hose, N/A	Pump to Room 3	N/A	Gray	N/A	N/A
Hose, N/A	Pump to Room 4	N/A	Red	N/A	N/A
Travel Clamp	Two per Slide	2		HWH	N/A

Measuring from inside of firewall, this is the end location of the hydraulic hoses where they attach to the slide mechanism.

Options

Revisions

1	Update per Equalizer Specs
2	Add Magellan to usage in header per ECN 4582
3	Cease building Magellan, omit name from header per ECN 6657 (8-25-09)

**32A WINDSPORT (19.5) TIRES
EQUALIZER JACKS (FULLY AUTOMATIC)
OPTIONAL ON THIS UNIT**

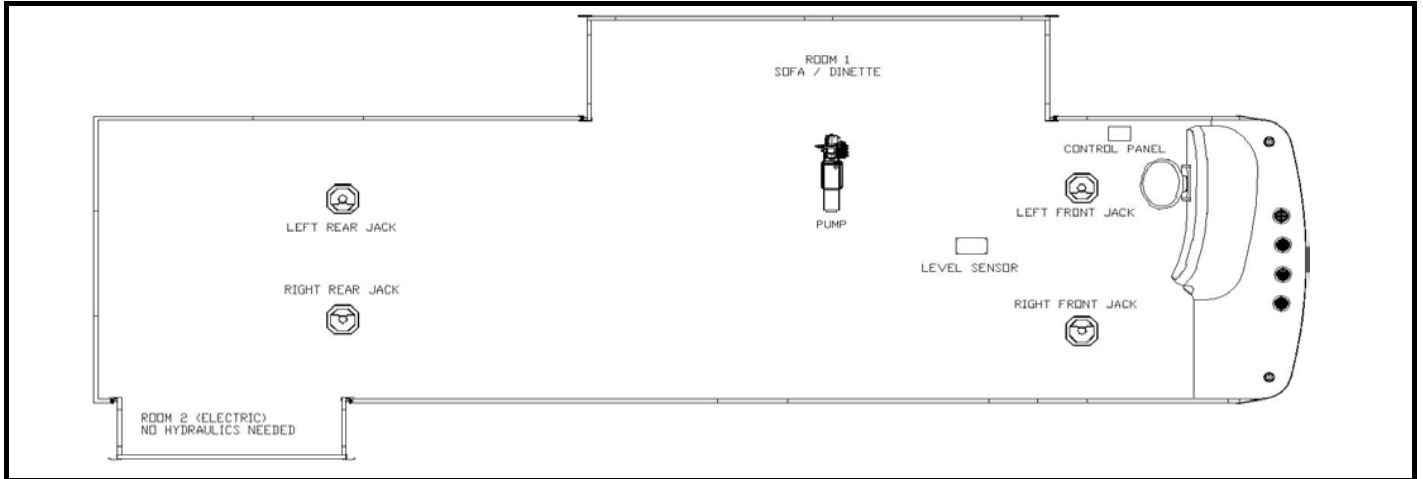

Notes:

- 1) Jacks mount in two different locations on bracket depending on tire size of chassis.
 - a) 19.5 Tires: Top hole in jack to top hole in bracket. Use 4 bolts in welded area of bracket.
 - b) 22.5 Tires: Top hole in jack to second hole in bracket. Use 6 bolts, 4 in welded area of bracket & 2 below welded area.

Item, Length	Description / Location	Qty	Color	Vendor PN		
Kit	(Items listed below)	1		8270		
Pump	5-Function, 1 Room, Jacks	1		7242BR		
Jack	12,000 lbs, 16" Stroke	4		7214		
Touch Pad	Located to the left of the drivers seat	1		2318	Measuring from front of bumper, this is the end location of the hydraulic hoses where they attach to the slide mechanism.	
Control Box	Attached to bottom of structure	1		2730		
Sync Cylinder	Mounted behind pump compartment	N/A		N/A		
Hose, 144	Pump to Jack, Left Front	2	Brown	2467		
Hose, 216	Pump to Jack, Left Rear	2	Orange	2473		
Hose, 192	Pump to Jack, Right Front	1	White	2471		
Hose, 264	Pump to Jack, Right Rear	1	Yellow	2476		
Hose, 96	Left Front Jack, Right Front Jack	1	Whi/Brn.	2463		N/A
Hose, 96	Left Rear Jack, Right Rear Jack	1	Yel/Ora.	2463		N/A
Hose, 36	Pump to Room 1	2	Green	2458		144 / Drivers Side (COIL AT PUMP)
Slide Unit	Room 1-36" Above floor slide (bolt-in)	1		7164B		
Hose, N/A	Pump to Room 2	N/A	Purple	N/A	N/A	
Slide Unit	Room 2					
Hose, N/A	Pump to Room 3	N/A	Gray	N/A	N/A	
Slide Unit	Room 3					
Hose, N/A	Pump to Room 4	N/A	Red	N/A	N/A	
Slide Unit	Room 4					
Travel Clamp	Two per Slide	N/A		HWH	N/A	

Options

Revisions

**32V WINDSPORT
(22.5) TIRES
EQUALIZER JACKS (FULLY AUTOMATIC)
STANDARD ON THIS UNIT**

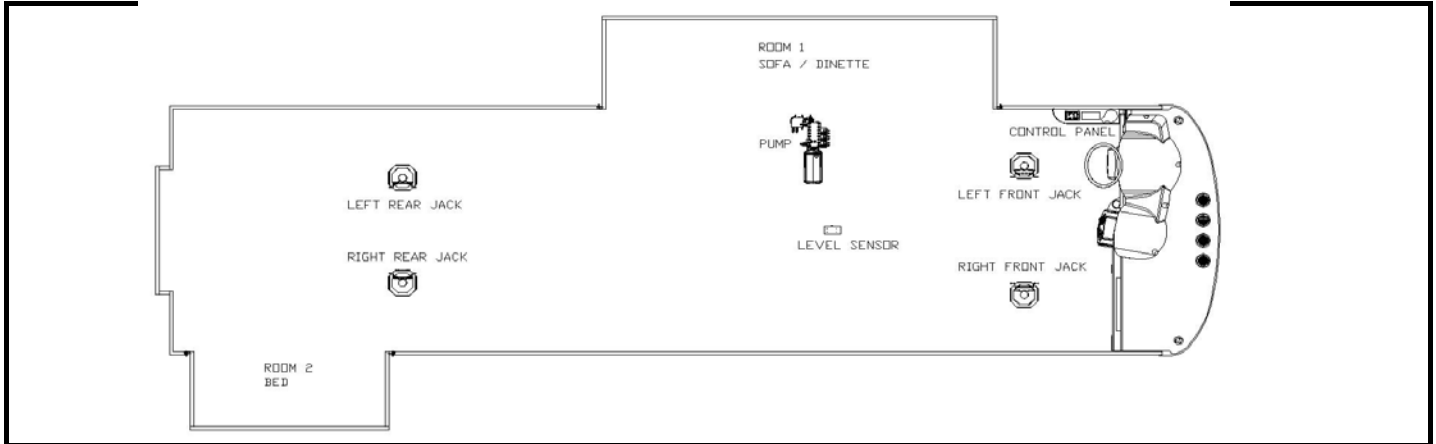

Notes:

- 1) Jacks mount in two different locations on bracket depending on tire size of chassis.
 - a) 19.5 Tires: Top hole in jack to top hole in bracket. Use 4 bolts in welded area of bracket.
 - b) 22.5 Tires: Top hole in jack to second hole in bracket. Use 6 bolts, 4 in welded area of bracket & 2 below welded area.

Item, Length	Description / Location	Qty	Color	Vendor PN	
Kit	(Items listed below)	1		8308	Measuring from inside of firewall, this is the end location of the hydraulic hoses where they attach to the slide mechanism.
Pump	6-Function, 2 Rooms & Jacks	1		7243BR	
Jack	12,000 lbs, 16" Stroke	4		7214	
Touch Pad	Located to the left of the drivers seat	1		2318	
Control Box	Attached to bottom of structure	1		2730	
Sync Cylinder	Mounted behind pump compartment	N/A		N/A	
Hose, 144	Pump to Jack, Left Front	2	Brown	2467	
Hose, 240	Pump to Jack, Left Rear	2	Orange	2475	
Hose, 192	Pump to Jack, Right Front	1	White	2471	
Hose, 288	Pump to Jack, Right Rear	1	Yellow	2478	
Hose, 96	Left Front Jack, Right Front Jack	1	Whi/Brn	2463	
Hose, 96	Left Rear Jack, Right Rear Jack	1	Yel/Ora.	2463	
Hose, 36	Pump to Room 1	2	Green	2458	127 / Drivers Side
Slide Unit	Room 1-36" Above floor slide	1		7164	
Hose, 384	Pump to Room 2	2	Purple	2482	310 / Passenger Side
Slide Unit	Room 2-30" Lippert Bed Slide	1		134998	
Hose, N/A	Pump to Room 3	N/A	Gray	N/A	N/A
Slide Unit					
Hose, N/A	Pump to Room 4	N/A	Red	N/A	N/A
Slide Unit					
Travel Clamp	Two per Slide	N/A		HWH	N/A

Options

Revisions

1	New model per ECN 6638 (8-25-09)

**34B WINDSPORT (22.5) TIRES
EQUALIZER JACKS (FULLY AUTOMATIC)
STANDARD ON THIS UNIT**

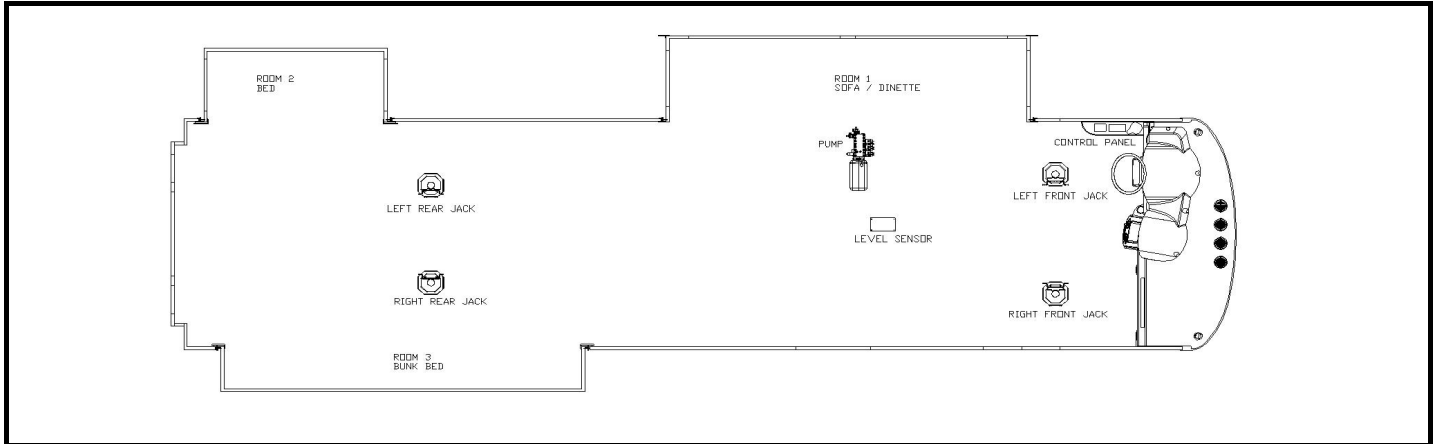

Notes:

- 1) Jacks mount in two different locations on bracket depending on tire size of chassis.
 - a) 19.5 Tires: Top hole in jack to top hole in bracket. Use 4 bolts in welded area of bracket.
 - b) 22.5 Tires: Top hole in jack to second hole in bracket. Use 6 bolts, 4 in welded area of bracket & 2 below welded area.

Item, Length	Description / Location	Qty	Color	Vendor PN		
Kit	(Items listed below)	1		8323	Measuring from inside of firewall, this is the end location of the hydraulic hoses where they attach to the slide mechanism.	
Pump	7-Function, 3 Rooms & Jacks	1		7301BR		
Jack	12,000 lbs, 16" Stroke	4		7214		
Touch Pad	Located to the left of the drivers seat	1		2318		
Control Box	Attached to bottom of structure	1		2730		
Sync Cylinder	Mounted behind pump compartment	N/A		N/A		
Hose, 144	Pump to Jack, Left Front	2	Brown	2467		
Hose, 240	Pump to Jack, Left Rear	2	Orange	2475		
Hose, 168	Pump to Jack, Right Front	2	White	2469		
Hose, 264	Pump to Jack, Right Rear	1	Yellow	2476		
Hose, 96	Left Rear Jack, Right Rear Jack	1	Yel/Ora	2463		
Hose, 36	Pump to Room 1	2	Green	2458		127 / Drivers Side
Slide Unit	Room 1-36" Above Floor Slide	1		7164		
Hose, 384	Pump to Room 2	2	Purple	2482		347 / Drivers Side
Slide Unit	Room 2-30" Bed Slide(Lipper)	1		134998		
Hose w90, 384	Pump to Room 3	2	Gray	2482		307 / Passenger Side
Slide Unit	Room 3-18" Above floor slide	1		7135		
Hose, N/A	Pump to Room 4	N/A	Red	N/A	N/A	
Travel Clamp	Two per Slide	N/A		N/A	N/A	

Options

Revisions

1	Update per Equalizer Specs
2	Add Magellan to chart, same as Windsport per ECN 4582.
3	Cease building Magellan, omit name from header per ECN 6657 (8-25-09)

**36F WINDSPORT (22.5) TIRES
EQUALIZER JACKS (FULLY AUTOMATIC)
STANDARD ON THIS UNIT**

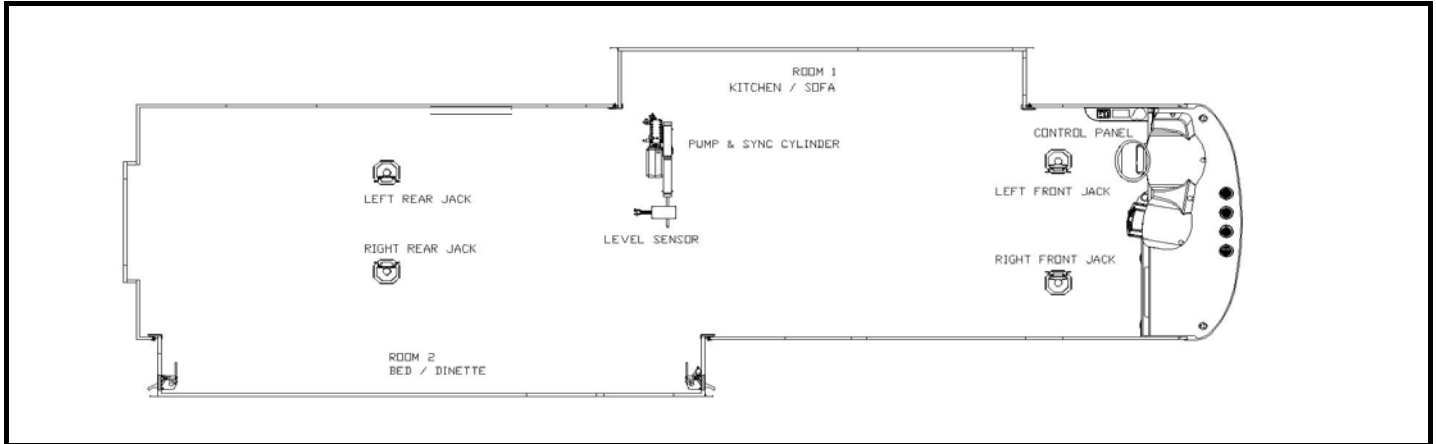

Notes:

- 1) Jacks mount in two different locations on bracket depending on tire size of chassis.
 - a) 19.5 Tires: Top hole in jack to top hole in bracket. Use 4 bolts in welded area of bracket.
 - b) 22.5 Tires: Top hole in jack to second hole in bracket. Use 6 bolts, 4 in welded area of bracket & 2 below welded area.
 - c) Hydraulic hose terminations for both rooms require 90 degree swivel elbows.

Item, Length	Description / Location	Qty	Color	Vendor PN	
Kit	(Items listed below)	1		8366	
Pump	6-Function, 2 Rooms & Jacks	1		7243BR	
Jack	12,000 lbs, 16" Stroke	4		7214	
Touch Pad	Located to the left of the drivers seat	1		2318	
Level Controller	Attached to bottom of structure	1		2730	
Sync Cylinder	Mounted inside pump compartment	1		7397	
Hose, 240	Pump to Jack, Left Front	2	Brown	2475	
Hose, 168	Pump to Jack, Left Rear	2	Orange	2469	
Hose, 264	Pump to Jack, Right Front	1	White	2476	
Hose, 216	Pump to Jack, Right Rear	1	Yellow	2473	
Hose, 96	Left Front Jack, Right Front Jack	1	Whi/Brn	2463	
Hose, 96	Left Rear Jack, Right Rear Jack	1	Yel/Ora.	2463	
Hose w/90, 120	Pump to Room 1	2	Green	2465	135 / Drivers Side
Slide Unit	Room 1 - 24" above floor slide	1		7369	
Hose, 36	Pump to sync cylinder	2	Purple	2458	Inside pump compartment
Hose w/90, 240	Sync cylinder to front slide, Room 2	2	Purple	2475	225 / Passenger Side
Hose w/90, 240	Sync cylinder to rear slide, Room 2	2	Purple	2475	371 / Passenger Side
Slide Unit	Room 2 - 24" flush floor slide (angled)	2		7388	
Hose, N/A	Pump to Room 3	N/A	Gray	N/A	N/A
Hose, N/A	Pump to Room 4	N/A	Red	N/A	N/A
Travel Clamp	Two per Slide	2		HWH	N/A

Measuring from inside of firewall, this is the end location of the hydraulic hoses where they attach to the slide mechanism.

Options

Revisions

1	Update per Equalizer Specs
2	Add Magellan to usage in header per ECN 4582
3	Cease building Magellan, omit name from header per ECN 6657 (8-25-09)

**38D MONTECITO
EQUALIZER JACKS (FULLY AUTOMATIC)
STANDARD ON THIS UNIT**

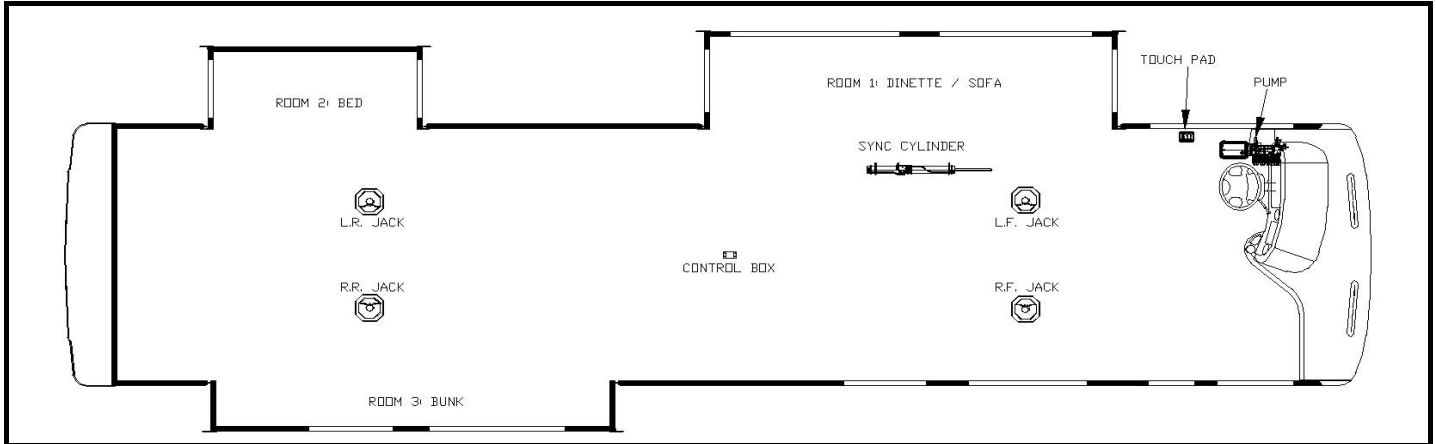

- Notes:**
- 1) Jacks mount to chassis brackets with the lowest holes of the jacks aligned with the lowest holes of the mounting brackets.
 - 2) Level sensor attaches to bottom of structure; on lower hat section flanges or square tube.
 - 3) Hydraulic hose terminations for room #1 & #3 require 90 degree swivel elbows.
 - 4) Reference FM-3991 for a better visual of Room 1 hydraulic connections.
 - 5) Hoses marked w90 will have the 90 deg fitting shipped loose.

Item, Length	Description / Location	Qty	Color	Vendor PN	
Kit	(Items listed below)	1		8347	
Pump	7-Function, 3 Rooms & Jacks	1		7319BR	
Jack	17,000 lbs, 18" Stroke	4		7134	
Touch Pad	Located to the left of the drivers seat	1		2318	
Control Box	Attached to bottom of structure	1		2730	
Sync Cylinder	Mounted behind LP tank	1		7387	
Hose, 144	Pump to Jack, Left Front	2	Brown	2467	
Hose, 384	Pump to Jack, Left Rear	2	Orange	2482	
Hose, 144	Pump to Jack, Right Front	2	White	2467	
Hose, 408	Pump to Jack, Right Rear	1	Yellow	2484	
Hose, 120	Left Rear Jack, Right Rear Jack	1	Yel/Ora	2465	
Hose, 144	Pump to synchronizing manifold	2	Green	2467	Mounts to bracket on structure
Hose w90, 168	Sync cylinder to front slide, Room 1	2	Green	2469	103 / Drivers side
Hose w90, 168	Sync cylinder to rear slide, Room 1	2	Green	2469	196 / Drivers side
	Pump to Room 1	N/A	Green		
Slide Unit	Room 1 - 36" flush floor slide	2		7523	
Hose, 456	Pump to Room 2	2	Purple	2488	325 / Drivers Side
Slide Unit	Room 2 - 30" Bed slide (Lippert)	1		134998	
Hose w90, 480	Pump to Room 3	2	Gray	2490	355 / Passenger Side
Slide Unit	Room 3 - 18" above floor slide	1		7135	
	Pump to Generator Slide	N/A			
Travel Clamp	(two per slide, dinette / sofa slide only)	2		HWH	N/A

Measuring from inside of firewall, this is the end location of the hydraulic hoses where they attach to the slide mechanism.

Options

Revisions

1	4-7-08, Corrected part number for 36" room, requires angled 36" in-floor mechanism #7523
2	4-23-08, Updated to match EQ's new way of plumbing jacks.

**38E MONTECITO
EQUALIZER JACKS (FULLY AUTOMATIC)
STANDARD ON THIS UNIT**

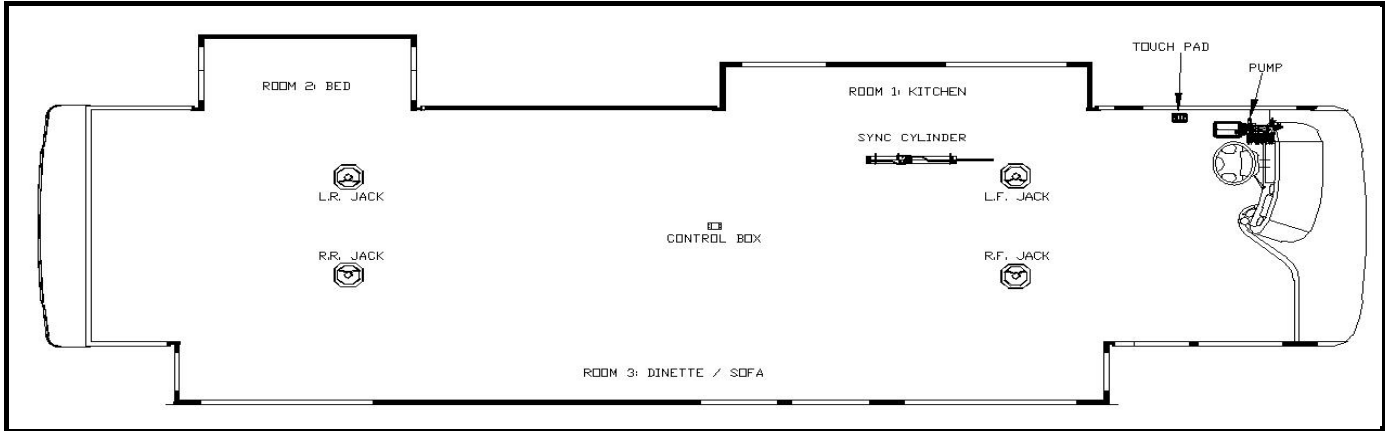

Notes:

- 1) Jacks mount to chassis brackets with the lowest holes of the jacks aligned with the lowest holes of the mounting brackets.
- 2) Level sensor attaches to bottom of structure; on the square tube the runs full length from axle to axle.
- 3) Hydraulic hose terminations for room #2 & #3 require 90 degree swivel elbows.
- 4) Room #3 will have a non-powered slide mechanism in center of room
- 5) Hoses marked w90 will have the 90 deg fitting shipped loose.

Item, Length	Description / Location	Qty	Color	Vendor PN	
Kit	(Items listed below)	1		8350	
Pump	7-Function, 3 Rooms & Jacks	1		7319BR	
Jack	17,000 lbs, 18" Stroke	4		7134	
Touch Pad	Located to the left of the drivers seat	1		2318	
Control Box	Attached to bottom of structure	1		2730	
Sync Cylinder	Mounted behind LP tank	1		7397	
Hose, 144	Pump to Jack, Left Front	2	Brown	2467	
Hose, 432	Pump to Jack, Left Rear	2	Orange	2486	
Hose, 144	Pump to Jack, Right Front	2	White	2467	
Hose, 432	Pump to Jack, Right Rear	1	Yellow	2486	
Hose, 120	Left Rear Jack, Right Rear Jack	1	Yel/ Ora	2465	
Hose, 144	Pump to synchronizing cylinder	2	Gray	2467	Mounts to bracket on structure
Hose w90, 456	Sync cylinder to front slide, Room 3	2	Gray	2488	103 / Passenger Side
Hose w90, 456	Sync cylinder to rear slide, Room 3	2	Gray	2488	350 / Passenger Side
Slide Unit	Room 3 - 24" flush floor slide (angled)	2		7388	
Slide Unit	Room 3 - 24" flush floor slide (angled)	1		7384	Slave
Hose w90, 192	Pump to Room 1	2	Green	2471	146 / Drivers Side
Slide Unit	Room 1 - 18" above floor slide	1		7135	
Hose, 528	Pump to Room 2	2	Purple	2566	345 / Drivers Side
Slide Unit	Room 2 - 30" Bed slide (Lippert)	1		134998	
	Pump to Generator Slide	N/A			N/A
Travel Clamp	(two per slide, except the bed slide)	4		HWH	N/A

Measuring from inside of firewall, this is the end location of the hydraulic hoses where they attach to the slide mechanism.

Options

Revisions

1	4-23-08, Updated to match EQ's new way of plumbing jacks.

**40J MONTECITO
EQUALIZER JACKS (FULLY AUTOMATIC)
STANDARD ON THIS UNIT**

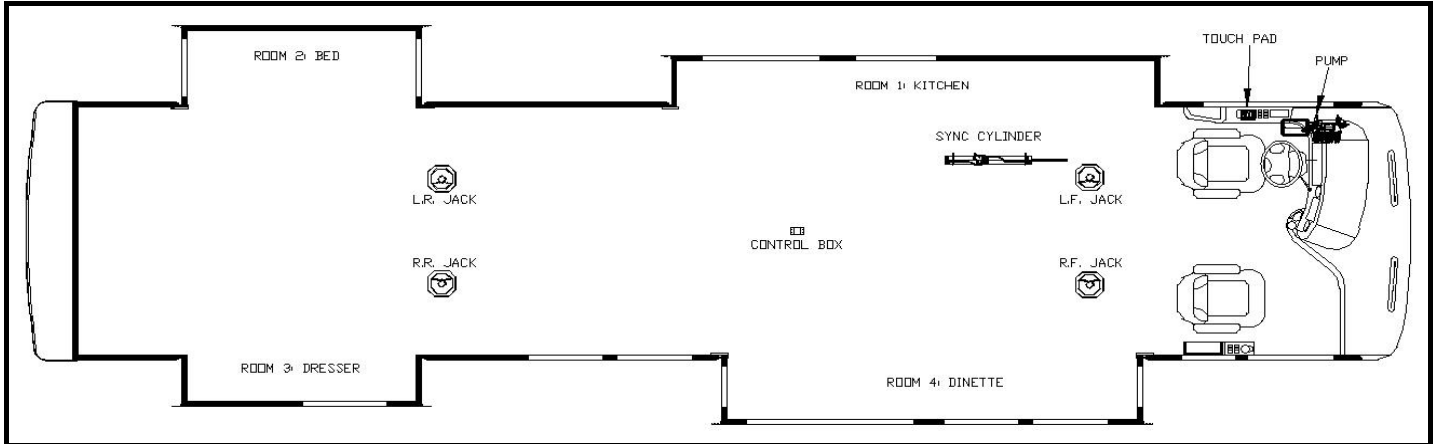

Notes:

- 1) Jacks mount to chassis brackets with the lowest holes of the jacks aligned with the lowest holes of the mounting brackets.
- 2) Level sensor attaches to bottom of structure; on the square tube the runs full length from axle to axle.
- 3) Hydraulic hose terminations for room #1, #3, & #4 require 90 degree swivel elbows.
- 4) Reference FM-3991 for a better visual of Room 4 hydraulic connections.
- 5) Hoses marked w90 will have the 90 deg fitting shipped loose.

Item, Length	Description / Location	Qty	Color	Vendor PN	
Kit	(Items listed below)	1		8421	
Pump	8-Function, 4 Rooms & Jacks	1		7302BR	
Jack	17,000 lbs, 18" Stroke	4		7134	
Touch Pad	Located to the left of the drivers seat	1		2318	
Control Box	Attached to bottom of structure	1		2730	
Sync Cylinder	Mounted behind LP tank	1		7397	
Sync Cylinder	Mounted behind LP tank	1		7511	
Hose, 144	Pump to Jack, Left Front	2	Brown	2467	
Hose, 408	Pump to Jack, Left Rear	2	Orange	2484	
Hose, 144	Pump to Jack, Right Front	2	White	2467	
Hose, 408	Pump to Jack, Right Rear	1	Yellow	2484	
Hose, 120	Left Rear Jack, Right Rear Jack	1	Yel/ Ora	2465	
Hose, 192	Pump to synchronizing cylinder	2	Green	2471	Mounts to bracket on structure
Hose w90, 144	Sync cylinder to front slide, Room 1	2	Green	2467	124 / Drivers side
Hose w90, 144	Sync cylinder to rear slide, Room 1	2	Green	2467	214 / Drivers side
Slide Unit	Room 1 - 18" above floor slide	2		7135	
Hose, 480	Pump to Room 2	2	Purple	2490	386 / Drivers Side
Slide Unit	Room 2 - 30" Bed slide (Lippert)	1		134998	
Hose w90, 480	Pump to Room 3	2	Gray	2490	365 / Passenger Side
Slide Unit	Room 3 - 18" above floor slide	1		7135	
Hoes, 192	Pump to synchronizing cylinder	2	Red	2471	Mounts to bracket on structure
Hose w90, 144	Sync cylinder to front slide, Room 4	2	Red	2467	124 / Passenger side
Hose w90, 144	Sync cylinder to rear slide, Room 4	2	Red	2467	214 / Passenger side
Slide Unit	Room 4 - 24" flush floor slide	2		7388	
	Pump to Generator Slide	N/A			N/A
Travel Clamp	(two per slide, except the bed slide)	6		HWH	N/A
Options					
Revisions					

Measuring from inside of firewall, this is the end location of the hydraulic hoses where they attach to the slide mechanism.

**42B MONTECITO
EQUALIZER JACKS (FULLY AUTOMATIC)
STANDARD ON THIS UNIT**

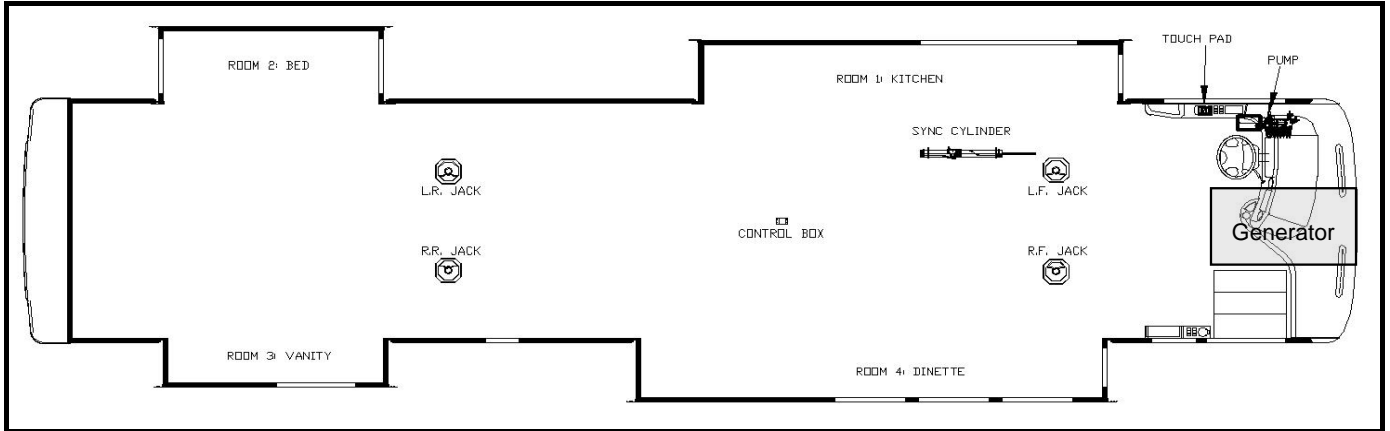

Notes:

- 1) Jacks mount to chassis brackets with the lowest holes of the jacks aligned with the lowest holes of the mounting brackets.
- 2) Level sensor attaches to bottom of structure; on the square tube the runs full length from axle to axle.
- 3) Hydraulic hose terminations for room #1 & #3 require 90 degree swivel elbows.
- 4) Hoses marked w90 will have the 90 deg fitting shipped loose.

Item, Length	Description / Location	Qty	Color	Vendor PN	
Kit	(Items listed below)	1		8508	
Pump	9-Function, 4 Rooms & Jacks	1		7650BR	
Jack	17,000 lbs, 18" Stroke	4		7134	
Touch Pad	Located to the left of the drivers seat	1		2318	
Control Box	Attached to bottom of structure	1		2730	
Sync Cylinder	Mounted behind LP tank	2		7397	
Hose, 144	Pump to Jack, Left Front	2	Brown	2467	
Hose, 408	Pump to Jack, Left Rear	2	Orange	2484	
Hose, 144	Pump to Jack, Right Front	2	White	2467	
Hose, 408	Pump to Jack, Right Rear	1	Yellow	2484	
Hose, 120	Left Rear Jack, Right Rear Jack	1	Yel/ Ora	2465	
Hose, 168	Pump to synchronizing cylinder	2	Green	2469	Mounts to bracket on structure
Hose w90, 168	Sync cylinder to front slide, Room 1	2	Green	2469	115 / Drivers side
Hose w90, 168	Sync cylinder to rear slide, Room 1	2	Green	2469	205 / Drivers side
Slide Unit	Room 1 - 24" flush floor slide (angled)	2		7388	
Hose, 528	Pump to Room 2	2	Purple	2566	420 / Drivers Side
Slide Unit	Room 2 - 30" Bed slide (Lippert)	1		134998	
Hose w90, 528	Pump to Room 3	2	Gray	2566	404 / Passenger side
Slide Unit	Room 3 - 18" above floor slide	1		7135	
Hose, 168	Pump to synchronizing cylinder	2	Red	2469	Mounts to bracket on structure
Hose w90, 288	Sync cylinder to front slide, Room 4	2	Red	2478	115 / Passenger side
Hose w90, 288	Sync cylinder to rear slide, Room 4	2	Red	2478	254 / Passenger side
Slide Unit	Room 4 - 24" flush floor slide (angled)	2		7388	
Hose, 72	Pump to Generator Slide	2	Blue	2461	Inside generator tray
Travel Clamp	(two per slide, except the bed slide)	6		HWH	N/A

Measuring from inside of firewall, this is the end location of the hydraulic hoses where they attach to the slide mechanism.

Options

Revisions

1	4-23-08, Updated to match EQ's new way of plumbing jacks.

**42C MONTECITO
EQUALIZER JACKS (FULLY AUTOMATIC)
STANDARD ON THIS UNIT**

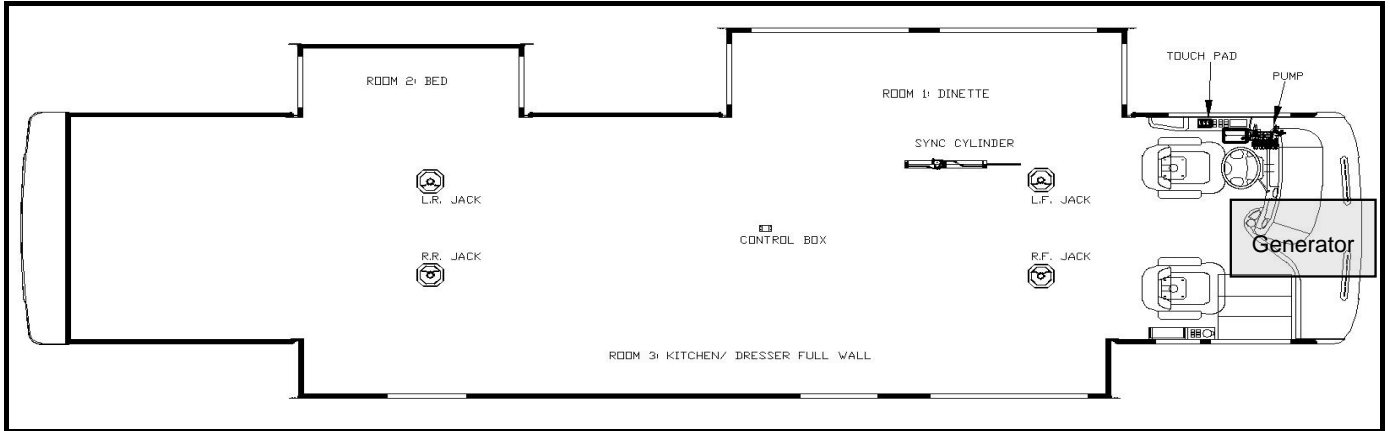

Notes:

- 1) Jacks mount to chassis brackets with the lowest holes of the jacks aligned with the lowest holes of the mounting brackets.
- 2) Level sensor attaches to bottom of structure; on the square tube the runs full length from axle to axle.
- 3) Hydraulic hose terminations for room #1 & #3 require 90 degree swivel elbows.
- 4) Hoses marked w90 will have the 90 deg fitting shipped loose.

Item, Length	Description / Location	Qty	Color	Vendor PN	
Kit	(Items listed below)	1		8526	
Pump	8-Function, 3 Rooms & Jacks	1		7302BR	
Jack	17,000 lbs, 18" Stroke	4		7134	
Touch Pad	Located to the left of the drivers seat	1		2318	
Control Box	Attached to bottom of structure	1		2730	
Sync Cylinder	Mounted behind LP tank	1		7387	
Sync Cylinder	Mounted behind LP tank	1		7397	
Hose, 144	Pump to Jack, Left Front	2	Brown	2467	
Hose, 408	Pump to Jack, Left Rear	2	Orange	2484	
Hose, 144	Pump to Jack, Right Front	2	White	2467	
Hose, 408	Pump to Jack, Right Rear	1	Yellow	2484	
Hose, 120	Left Rear Jack, Right Rear Jack	1	Yel/ Ora	2465	
Hose, 168	Pump to synchronizing cylinder	2	Green	2469	Mounts to bracket on structure
Hose w90, 168	Sync cylinder to front slide, Room 1	2	Green	2469	115 / Drivers side
Hose w90, 168	Sync cylinder to rear slide, Room 1	2	Green	2469	205 / Drivers side
Slide Unit	Room 1 - 36" flush floor slide (angled)	2		7523	
Hose, 480	Pump to Room 2	2	Purple	2490	402 / Drivers Side
Slide Unit	Room 2 - 30" Bed slide (Lippert)	1		134998	
Hose, 168	Pump to synchronizing cylinder	2	Grey	2469	Mounts to bracket on structure
Hose w90, 336	Sync cylinder to front slide, Room 3	2	Grey	2535	115 / Passenger side
Hose w90, 336	Sync cylinder to rear slide, Room 3	2	Grey	2535	300 / Passenger side
Slide Unit	Room 3 - 24" above floor slide	2		7369	
Slide Unit	Room 3 - 24" above floor slide	1		7662	Slave
Hose, 72	Pump to Generator Slide	2	Red	2461	Inside generator tray
Travel Clamp	(two per slide, except the bed slide)	4		HWH	N/A

Measuring from inside of firewall, this is the end location of the hydraulic hoses where they attach to the slide mechanism.

Options

Revisions

**38E MONTECITO
EQUALIZER JACKS (FULLY AUTOMATIC)
STANDARD ON THIS UNIT**

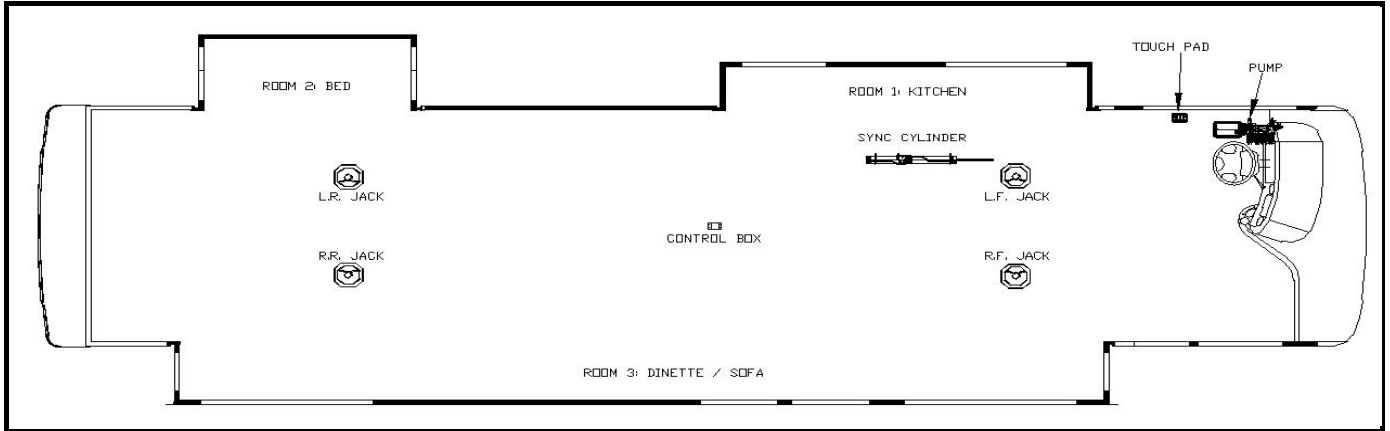

Notes:

- 1) Jacks mount to chassis brackets with the lowest holes of the jacks aligned with the lowest holes of the mounting brackets.
- 2) Level sensor attaches to bottom of structure; on the square tube the runs full length from axle to axle.
- 3) Hydraulic hose terminations for room #2 & #3 require 90 degree swivel elbows.
- 4) Room #3 will have a non-powered slide mechanism in center of room
- 5) Hoses marked w90 will have the 90 deg fitting shipped loose.

Item, Length	Description / Location	Qty	Color	Vendor PN	
Kit	(Items listed below)	1		8350	
Pump	7-Function, 3 Rooms & Jacks	1		7319BR	
Jack	17,000 lbs, 18" Stroke	4		7134	
Touch Pad	Located to the left of the drivers seat	1		2318	
Control Box	Attached to bottom of structure	1		2730	
Sync Cylinder	Mounted behind LP tank	1		7397	
Hose, 144	Pump to Jack, Left Front	2	Brown	2467	
Hose, 432	Pump to Jack, Left Rear	2	Orange	2486	
Hose, 144	Pump to Jack, Right Front	2	White	2467	
Hose, 432	Pump to Jack, Right Rear	1	Yellow	2486	
Hose, 120	Left Rear Jack, Right Rear Jack	1	Yel/ Ora	2465	
Hose, 144	Pump to synchronizing cylinder	2	Gray	2467	Mounts to bracket on structure
Hose w90, 432	Sync cylinder to front slide, Room 3	2	Gray	2486	103 / Passenger Side
Hose w90, 456	Sync cylinder to rear slide, Room 3	2	Gray	2488	350 / Passenger Side
Slide Unit	Room 3 - 24" flush floor slide (angled)	2		7388	
Slide Unit	Room 3 - 24" flush floor slide (angled)	1		7384	Slave
Hose w90, 192	Pump to Room 1	2	Green	2471	146 / Drivers Side
Slide Unit	Room 1 - 18" above floor slide	1		7135	
Hose, 528	Pump to Room 2	2	Purple	2566	345 / Drivers Side
Slide Unit	Room 2 - 30" Bed slide (Lippert)	1		134998	
	Pump to Generator Slide	N/A			N/A
Travel Clamp	(two per slide, except the bed slide)	4		HWH	N/A

Measuring from inside of firewall, this is the end location of the hydraulic hoses where they attach to the slide mechanism.

Options

Revisions

1	4-23-08, Updated to match EQ's new way of plumbing jacks.

**40J MONTECITO
EQUALIZER JACKS (FULLY AUTOMATIC)
STANDARD ON THIS UNIT**

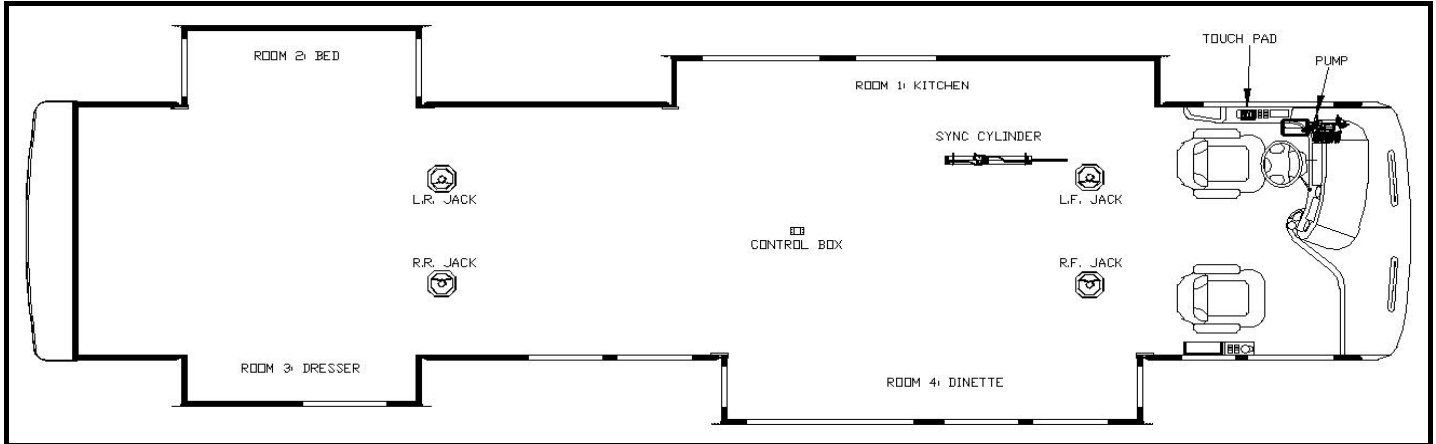

Notes:

- 1) Jacks mount to chassis brackets with the lowest holes of the jacks aligned with the lowest holes of the mounting brackets.
- 2) Level sensor attaches to bottom of structure; on the square tube the runs full length from axle to axle.
- 3) Hydraulic hose terminations for room #1, #3, & #4 require 90 degree swivel elbows.
- 4) Reference FM-3991 for a better visual of Room 4 hydraulic connections.
- 5) Hoses marked w90 will have the 90 deg fitting shipped loose.

Item, Length	Description / Location	Qty	Color	Vendor PN	
Kit	(Items listed below)	1		8421	
Pump	8-Function, 4 Rooms & Jacks	1		7302BR	
Jack	17,000 lbs, 18" Stroke	4		7134	
Touch Pad	Located to the left of the drivers seat	1		2318	
Control Box	Attached to bottom of structure	1		2730	
Sync Cylinder	Mounted behind LP tank	1		7397	
Sync Cylinder	Mounted behind LP tank	1		7511	
Hose, 144	Pump to Jack, Left Front	2	Brown	2467	
Hose, 408	Pump to Jack, Left Rear	2	Orange	2484	
Hose, 144	Pump to Jack, Right Front	2	White	2467	
Hose, 408	Pump to Jack, Right Rear	1	Yellow	2484	
Hose, 120	Left Rear Jack, Right Rear Jack	1	Yel/ Ora	2465	
Hose, 192	Pump to synchronizing cylinder	2	Green	2471	Mounts to bracket on structure
Hose w90, 144	Sync cylinder to front slide, Room 1	2	Green	2467	124 / Drivers side
Hose w90, 144	Sync cylinder to rear slide, Room 1	2	Green	2467	214 / Drivers side
Slide Unit	Room 1 - 18" above floor slide	2		7135	
Hose, 480	Pump to Room 2	2	Purple	2490	386 / Drivers Side
Slide Unit	Room 2 - 30" Bed slide (Lippert)	1		134998	
Hose w90, 480	Pump to Room 3	2	Gray	2490	365 / Passenger Side
Slide Unit	Room 3 - 18" above floor slide	1		7135	
Hoes, 192	Pump to synchronizing cylinder	2	Red	2471	Mounts to bracket on structure
Hose w90, 144	Sync cylinder to front slide, Room 4	2	Red	2467	124 / Passenger side
Hose w90, 144	Sync cylinder to rear slide, Room 4	2	Red	2467	214 / Passenger side
Slide Unit	Room 4 - 24" flush floor slide	2		7388	
	Pump to Generator Slide	N/A			N/A
Travel Clamp	(two per slide, except the bed slide)	6		HWH	N/A
Options					
Revisions					

Measuring from inside of firewall, this is the end location of the hydraulic hoses where they attach to the slide mechanism.

**42B MONTECITO
EQUALIZER JACKS (FULLY AUTOMATIC)
STANDARD ON THIS UNIT**

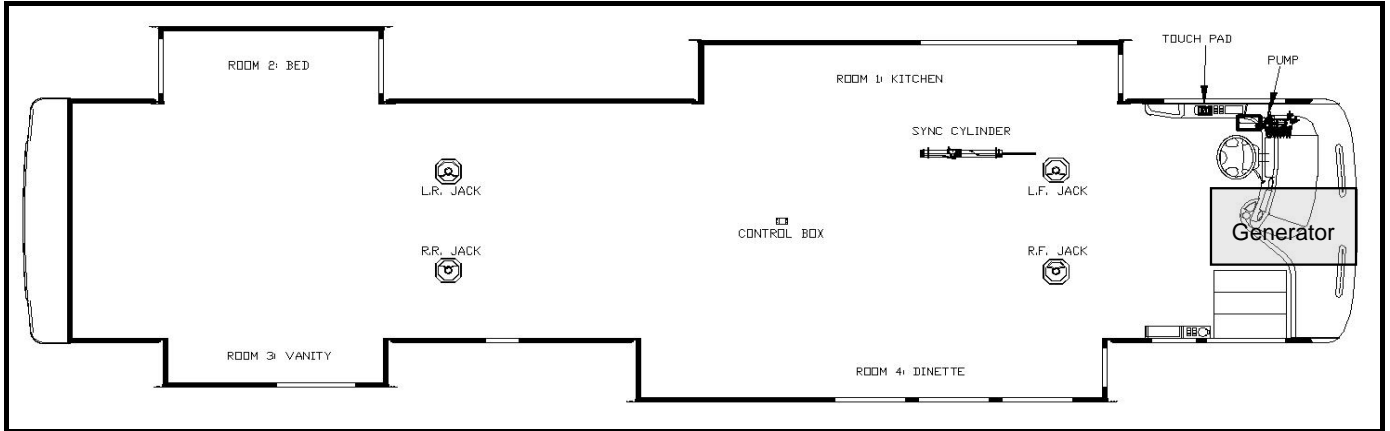

Notes:

- 1) Jacks mount to chassis brackets with the lowest holes of the jacks aligned with the lowest holes of the mounting brackets.
- 2) Level sensor attaches to bottom of structure; on the square tube the runs full length from axle to axle.
- 3) Hydraulic hose terminations for room #1 & #3 require 90 degree swivel elbows.
- 4) Hoses marked w90 will have the 90 deg fitting shipped loose.

Item, Length	Description / Location	Qty	Color	Vendor PN	
Kit	(Items listed below)	1		8508	
Pump	9-Function, 4 Rooms & Jacks	1		7650BR	
Jack	17,000 lbs, 18" Stroke	4		7134	
Touch Pad	Located to the left of the drivers seat	1		2318	
Control Box	Attached to bottom of structure	1		2730	
Sync Cylinder	Mounted behind LP tank	2		7397	
Hose, 144	Pump to Jack, Left Front	2	Brown	2467	
Hose, 408	Pump to Jack, Left Rear	2	Orange	2484	
Hose, 144	Pump to Jack, Right Front	2	White	2467	
Hose, 408	Pump to Jack, Right Rear	1	Yellow	2484	
Hose, 120	Left Rear Jack, Right Rear Jack	1	Yel/ Ora	2465	
Hose, 168	Pump to synchronizing cylinder	2	Green	2469	Mounts to bracket on structure
Hose w90, 168	Sync cylinder to front slide, Room 1	2	Green	2469	115 / Drivers side
Hose w90, 168	Sync cylinder to rear slide, Room 1	2	Green	2469	205 / Drivers side
Slide Unit	Room 1 - 24" flush floor slide (angled)	2		7388	
Hose, 528	Pump to Room 2	2	Purple	2566	420 / Drivers Side
Slide Unit	Room 2 - 30" Bed slide (Lippert)	1		134998	
Hose w90, 528	Pump to Room 3	2	Gray	2566	404 / Passenger side
Slide Unit	Room 3 - 18" above floor slide	1		7135	
Hose, 168	Pump to synchronizing cylinder	2	Red	2469	Mounts to bracket on structure
Hose w90, 288	Sync cylinder to front slide, Room 4	2	Red	2478	115 / Passenger side
Hose w90, 288	Sync cylinder to rear slide, Room 4	2	Red	2478	254 / Passenger side
Slide Unit	Room 4 - 24" flush floor slide (angled)	2		7388	
Hose, 72	Pump to Generator Slide	2	Blue	2461	Inside generator tray
Travel Clamp	(two per slide, except the bed slide)	6		HWH	N/A

Measuring from inside of firewall, this is the end location of the hydraulic hoses where they attach to the slide mechanism.

Options

Revisions

1	4-23-08, Updated to match EQ's new way of plumbing jacks.

**42C MONTECITO
EQUALIZER JACKS (FULLY AUTOMATIC)
STANDARD ON THIS UNIT**

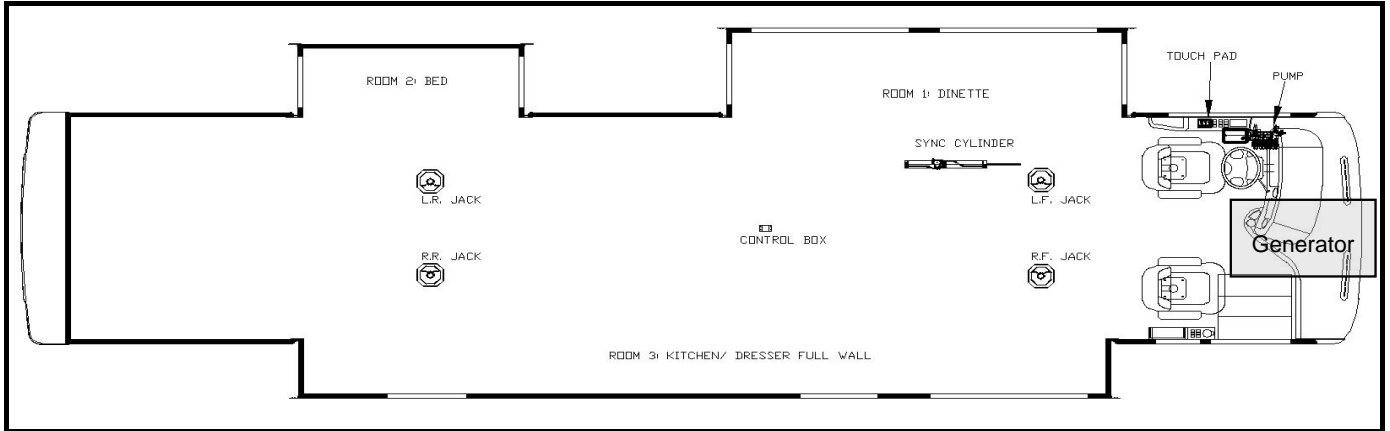

Notes:

- 1) Jacks mount to chassis brackets with the lowest holes of the jacks aligned with the lowest holes of the mounting brackets.
- 2) Level sensor attaches to bottom of structure; on the square tube the runs full length from axle to axle.
- 3) Hydraulic hose terminations for room #1 & #3 require 90 degree swivel elbows.
- 4) Hoses marked w90 will have the 90 deg fitting shipped loose.

Item, Length	Description / Location	Qty	Color	Vendor PN	
Kit	(Items listed below)	1		8526	
Pump	8-Function, 3 Rooms & Jacks	1		7302BR	
Jack	17,000 lbs, 18" Stroke	4		7134	
Touch Pad	Located to the left of the drivers seat	1		2318	
Control Box	Attached to bottom of structure	1		2730	
Sync Cylinder	Mounted behind LP tank	1		7387	
Sync Cylinder	Mounted behind LP tank	1		7397	
Hose, 144	Pump to Jack, Left Front	2	Brown	2467	
Hose, 408	Pump to Jack, Left Rear	2	Orange	2484	
Hose, 144	Pump to Jack, Right Front	2	White	2467	
Hose, 408	Pump to Jack, Right Rear	1	Yellow	2484	
Hose, 120	Left Rear Jack, Right Rear Jack	1	Yel/ Ora	2465	
Hose, 168	Pump to synchronizing cylinder	2	Green	2469	Mounts to bracket on structure
Hose w90, 168	Sync cylinder to front slide, Room 1	2	Green	2469	115 / Drivers side
Hose w90, 168	Sync cylinder to rear slide, Room 1	2	Green	2469	205 / Drivers side
Slide Unit	Room 1 - 36" flush floor slide (angled)	2		7523	
Hose, 480	Pump to Room 2	2	Purple	2490	402 / Drivers Side
Slide Unit	Room 2 - 30" Bed slide (Lippert)	1		134998	
Hose, 168	Pump to synchronizing cylinder	2	Grey	2469	Mounts to bracket on structure
Hose w90, 336	Sync cylinder to front slide, Room 3	2	Grey	2535	115 / Passenger side
Hose w90, 336	Sync cylinder to rear slide, Room 3	2	Grey	2535	300 / Passenger side
Slide Unit	Room 3 - 24" above floor slide	2		7369	
Slide Unit	Room 3 - 24" above floor slide	1		7662	Slave
Hose, 72	Pump to Generator Slide	2	Red	2461	Inside generator tray
Travel Clamp	(two per slide, except the bed slide)	4		HWH	N/A

Measuring from inside of firewall, this is the end location of the hydraulic hoses where they attach to the slide mechanism.

Options

Revisions

**38D Presidio
EQUALIZER JACKS (FULLY AUTOMATIC)
STANDARD ON THIS UNIT**

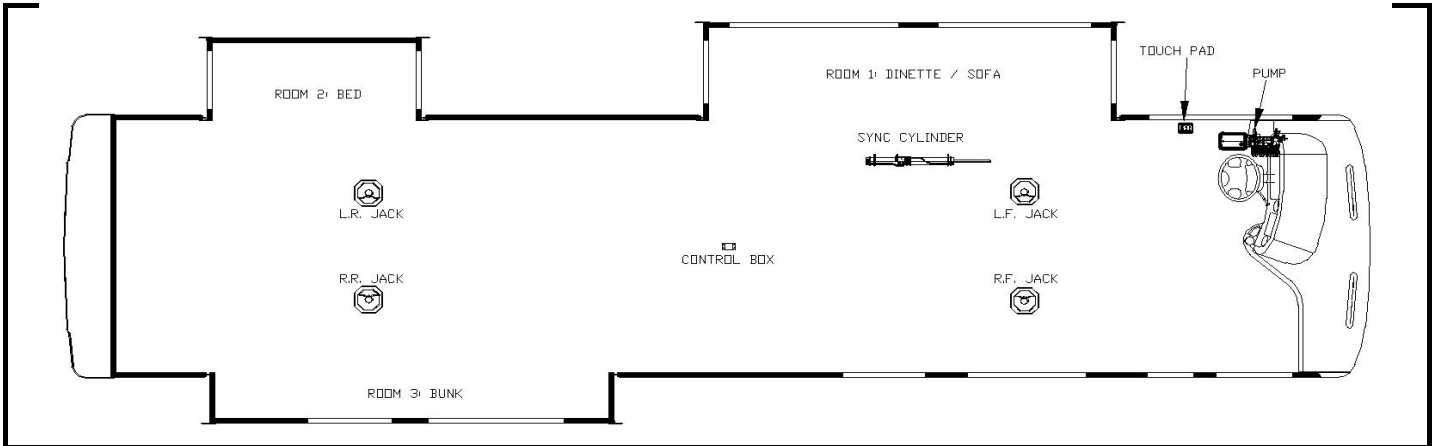

Notes:

- 1) Jacks mount to chassis brackets with the lowest holes of the jacks aligned with the lowest holes of the mounting brackets.
- 2) Level sensor attaches to bottom of structure; on lower hat section flanges or square tube.
- 3) Hydraulic hose terminations for room #1 & #3 require 90 degree swivel elbows.
- 4) Reference FM-3991 for a better visual of Room 1 hydraulic connections.
- 5) Hoses marked w90 will have the 90 deg fitting shipped loose.

Item, Length	Description / Location	Qty	Color	Vendor PN	
Kit	(Items listed below)	1		8347	
Pump	7-Function, 3 Rooms & Jacks	1		7319BR	
Jack	17,000 lbs, 18" Stroke	4		7134	
Touch Pad	Located to the left of the drivers seat	1		2318	
Control Box	Attached to bottom of structure	1		2730	
Sync Cylinder	Mounted behind LP tank	1		7387	
Hose, 132	Pump to Jack, Left Front	2	Brown	2466	
Hose, 384	Pump to Jack, Left Rear	2	Orange	2482	
Hose, 144	Pump to Jack, Right Front	2	White	2467	
Hose, 396	Pump to Jack, Right Rear	1	Yellow	2483	
Hose, 108	Left Rear Jack, Right Rear Jack	1	Yel/Ora	2464	
Hose, 144	Pump to synchronizing manifold	2	Green	2467	Mounts to bracket on structure
Hose w90, 168	Sync cylinder to front slide, Room 1	2	Green	2469	103 / Drivers side
Hose w90, 168	Sync cylinder to rear slide, Room 1	2	Green	2469	196 / Drivers side
	Pump to Room 1	N/A	Green		
Slide Unit	Room 1 - 36" flush floor slide	2		7523	
Hose, 444	Pump to Room 2	2	Purple	2487	325 / Drivers Side
Slide Unit	Room 2 - 30" Bed slide (Lippert)	1		134998	
Hose w90, 468	Pump to Room 3	2	Gray	2489	355 / Passenger Side
Slide Unit	Room 3 - 18" above floor slide	1		7135	
	Pump to Generator Slide	N/A			
Travel Clamp	(two per slide, dinette / sofa slide only)	2		HWH	N/A

Measuring from inside of firewall, this is the end location of the hydraulic hoses where they attach to the slide mechanism.

Options

Revisions

1	4-7-08, Corrected part number for 36" room, requires angled 36" in-floor mechanism #7523
2	4-23-08, Updated to match EQ's new way of plumbing jacks.

40J Presidio
EQUALIZER JACKS (FULLY AUTOMATIC)
STANDARD ON THIS UNIT

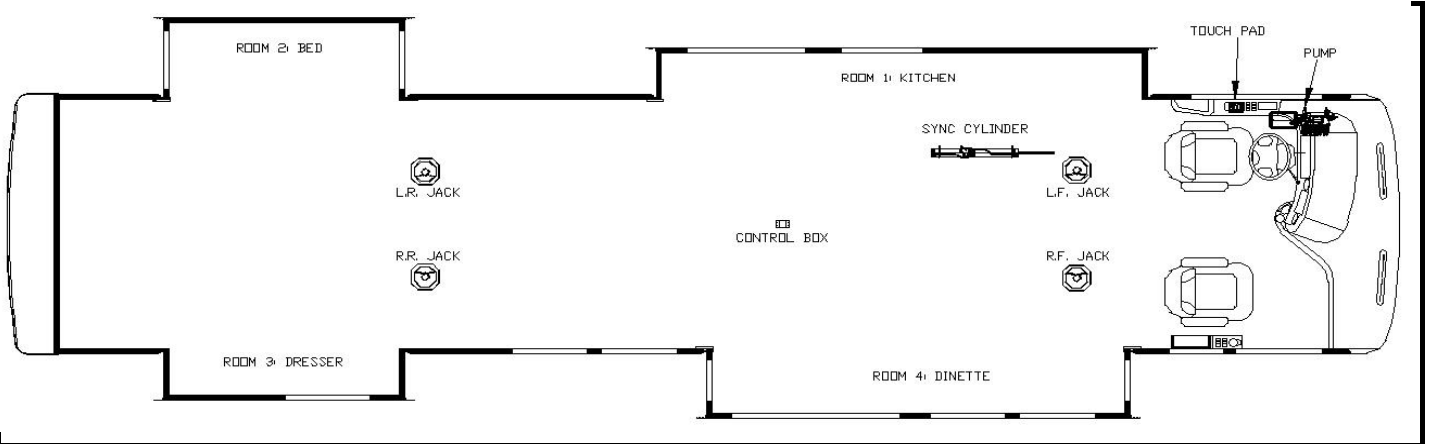

Notes:

- 1) Jacks mount to chassis brackets with the lowest holes of the jacks aligned with the lowest holes of the mounting brackets.
- 2) Level sensor attaches to bottom of structure; on the square tube the runs full length from axle to axle.
- 3) Hydraulic hose terminations for room #1, #3, & #4 require 90 degree swivel elbows.
- 4) Reference FM-3991 for a better visual of Room 4 hydraulic connections.
- 5) Hoses marked w90 will have the 90 deg fitting shipped loose.

Item, Length	Description / Location	Qty	Color	Vendor PN	
Kit	(Items listed below)	1		8421	
Pump	8-Function, 4 Rooms & Jacks	1		7302BR	
Jack	17,000 lbs, 18" Stroke	4		7134	
Touch Pad	Located to the left of the drivers seat	1		2318	
Control Box	Attached to bottom of structure	1		2730	
Sync Cylinder	Mounted behind LP tank	1		7397	
Sync Cylinder	Mounted behind LP tank	1		7511	
Hose, 144	Pump to Jack, Left Front	2	Brown	2467	
Hose, 408	Pump to Jack, Left Rear	2	Orange	2484	
Hose, 144	Pump to Jack, Right Front	2	White	2467	
Hose, 408	Pump to Jack, Right Rear	1	Yellow	2484	
Hose, 108	Left Rear Jack, Right Rear Jack	1	Yel/ Ora	2464	
Hose, 192	Pump to synchronizing cylinder	2	Green	2471	Mounts to bracket on structure
Hose w90, 144	Sync cylinder to front slide, Room 1	2	Green	2467	124 / Drivers side
Hose w90, 144	Sync cylinder to rear slide, Room 1	2	Green	2467	214 / Drivers side
Slide Unit	Room 1 - 18" above floor slide	2		7135	
Hose, 480	Pump to Room 2	2	Purple	2490	386 / Drivers Side
Slide Unit	Room 2 - 30" Bed slide (Lippert)	1		134998	
Hose w90, 480	Pump to Room 3	2	Gray	2490	365 / Passenger Side
Slide Unit	Room 3 - 18" above floor slide	1		7135	
Hoes, 192	Pump to synchronizing cylinder	2	Red	2471	Mounts to bracket on structure
Hose w90, 144	Sync cylinder to front slide, Room 4	2	Red	2467	124 / Passenger side
Hose w90, 144	Sync cylinder to rear slide, Room 4	2	Red	2467	214 / Passenger side
Slide Unit	Room 4 - 24" flush floor slide	2		7388	
	Pump to Generator Slide	N/A			N/A
Travel Clamp	(two per slide, except the bed slide)	6		HWH	N/A

Measuring from inside of firewall, this is the end location of the hydraulic hoses where they attach to the slide mechanism.

Options

Revisions

1	4-23-08, Updated to match EQ's new way of plumbing jacks.

**40K Presidio
EQUALIZER JACKS (FULLY AUTOMATIC)
STANDARD ON THIS UNIT**

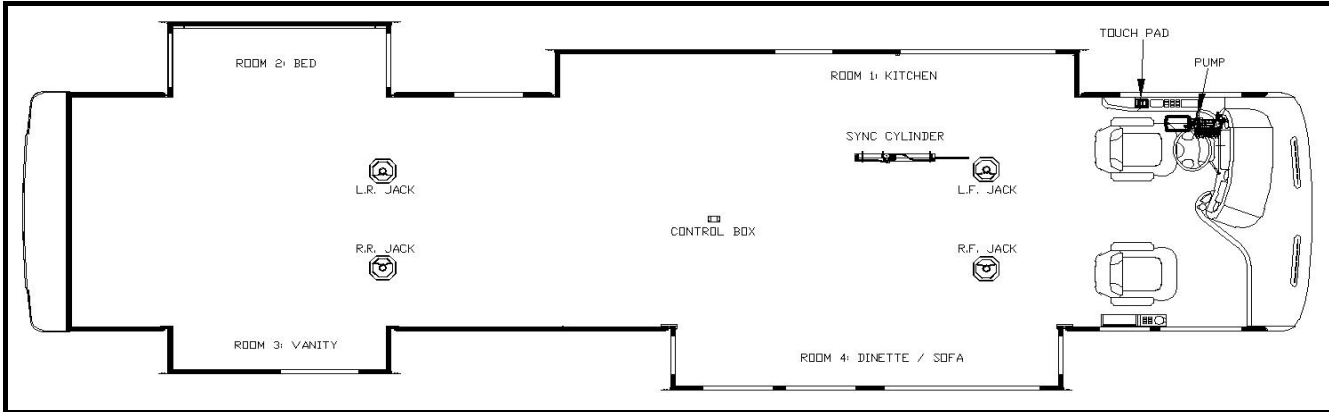

Notes:

- 1) Jacks mount to chassis brackets with the lowest holes of the jacks aligned with the lowest holes of the mounting brackets.
- 2) Level sensor attaches to bottom of structure; on the square tube the runs full length from axle to axle.
- 3) Hydraulic hose terminations for room #1, #3, & #4 require 90 degree swivel elbows.
- 4) Reference FM-3991 for a better visual of Room 4 hydraulic connections.
- 5) Hoses marked w90 will have the 90 deg fitting shipped loose.

Item, Length	Description / Location	Qty	Color	Vendor PN		
Kit	(Items listed below)	1		8418	Measuring from inside of firewall, this is the end location of the hydraulic hoses where they attach to the slide mechanism.	
Pump	8-Function, 4 Rooms & Jacks	1		7302BR		
Jack	17,000 lbs, 18" Stroke	4		7134		
Touch Pad	Located to the left of the drivers seat	1		2318		
Control Box	Attached to bottom of structure	1		2730		
Sync Cylinder	Mounted behind LP tank	1		7397		
Sync Cylinder	Mounted behind LP tank	1		7511		
Hose, 144	Pump to Jack, Left Front	2	Brown	2467		
Hose, 408	Pump to Jack, Left Rear	2	Orange	2484		
Hose, 144	Pump to Jack, Right Front	2	White	2467		
Hose, 408	Pump to Jack, Right Rear	1	Yellow	2484		
Hose, 108	Left Rear Jack, Right Rear Jack	1	Yel/ Ora	2464		
Hose, 192	Pump to synchronizing cylinder	2	Green	2471		Mounts to bracket on structure
Hose w90, 144	Sync cylinder to front slide, Room 1	2	Green	2467		124 / Drivers side
Hose w90, 144	Sync cylinder to rear slide, Room 1	2	Green	2467		214 / Drivers side
Slide Unit	Room 1 - 18" above floor slide	2		7135		
Hose, 480	Pump to Room 2	2	Purple	2490	386 / Drivers Side	
Slide Unit	Room 2 - 30" Bed slide (Lippert)	1		134998		
Hose w90, 480	Pump to Room 3	2	Gray	2490	365 / Passenger Side	
Slide Unit	Room 3 - 18" above floor slide	1		7135		
Hose, 192	Pump to synchronizing cylinder	2	Red	2471	Mounts to bracket on structure	
Hose w90, 144	Sync cylinder to front slide, Room 4	2	Red	2467	124 / Passenger side	
Hose w90, 144	Sync cylinder to rear slide, Room 4	2	Red	2467	214 / Passenger side	
Slide Unit	Room 4 - 24" flush floor slide	2		7388		
	Pump to Generator Slide	N/A			N/A	
Travel Clamp	(two per slide, except the bed slide)	6		HWH	N/A	
Options						
Revisions						
1	4-23-08, Updated to match EQ's new way of plumbing jacks.					

**42A Presidio
EQUALIZER JACKS (FULLY AUTOMATIC)
STANDARD ON THIS UNIT**

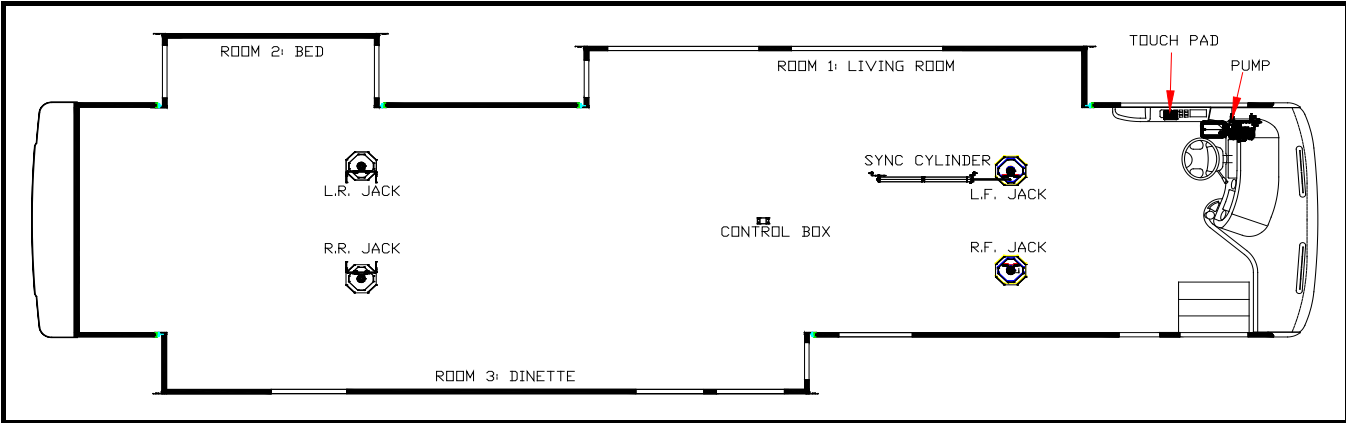

- Notes:**
- 1) Jacks mount to chassis brackets with the lowest holes of the jacks aligned with the lowest holes of the mounting brackets.
 - 2) Level sensor attaches to bottom of structure; on the square tube the runs full length from axle to axle.
 - 3) Hydraulic hose terminations for room #1 & #3 require 90 degree swivel elbows.
 - 4) Hoses marked w90 will have the 90 deg fitting shipped loose.

Item, Length	Description / Location	Qty	Color	Vendor PN		
Kit	(Items listed below)	1		8373	Measuring from inside of firewall, this is the end location of the hydraulic hoses where they attach to the slide mechanism.	
Pump	7-Function, 3 Rooms & Jacks	1		7319BR		
Jack	17,000 lbs, 18" Stroke	4		7134		
Touch Pad	Located to the left of the drivers seat	1		2318		
Control Box	Attached to bottom of structure	1		2730		
Sync Cylinder	Mounted behind LP tank	2		7397		
Hose, 144	Pump to Jack, Left Front	2	Brown	2467		
Hose, 408	Pump to Jack, Left Rear	2	Orange	2484		
Hose, 144	Pump to Jack, Right Front	2	White	2467		
Hose, 408	Pump to Jack, Right Rear	1	Yellow	2484		
Hose, 108	Left Rear Jack, Right Rear Jack	1	Yel/ Ora	2464		
Hose, 168	Pump to synchronizing cylinder	2	Green	2469		Mounts to bracket on structure
Hose w90, 168	Sync cylinder to front slide, Room 1	2	Green	2469		130 / Drivers side
Hose w90, 168	Sync cylinder to rear slide, Room 1	2	Green	2469		220 / Drivers side
Slide Unit	Room 1 - 24" flush floor slide (angled)	2		7388		
Hose, 516	Pump to Room 2	2	Purple	2491	420 / Drivers Side	
Slide Unit	Room 2 - 30" Bed slide (Lippert)	1		134998		
Hose, 168	Pump to synchronizing cylinder	2	Gray	2469	Mounts to bracket on structure	
Hose w90, 360	Sync cylinder to front slide, Room 3	2	Gray	2527	235 / Passenger side	
Hose w90, 360	Sync cylinder to rear slide, Room 3	2	Gray	2527	385 / Passenger side	
Slide Unit	Room 3 - 24" flush floor slide (angled)	2		7388		
	Pump to Generator Slide	N/A			N/A	
Travel Clamp	(two per slide, except the bed slide)	4		HWH	N/A	

Options

Revisions

1	4-23-08, Updated to match EQ's new way of plumbing jacks.

42B Sahara
EQUALIZER JACKS (FULLY AUTOMATIC)
STANDARD ON THIS UNIT

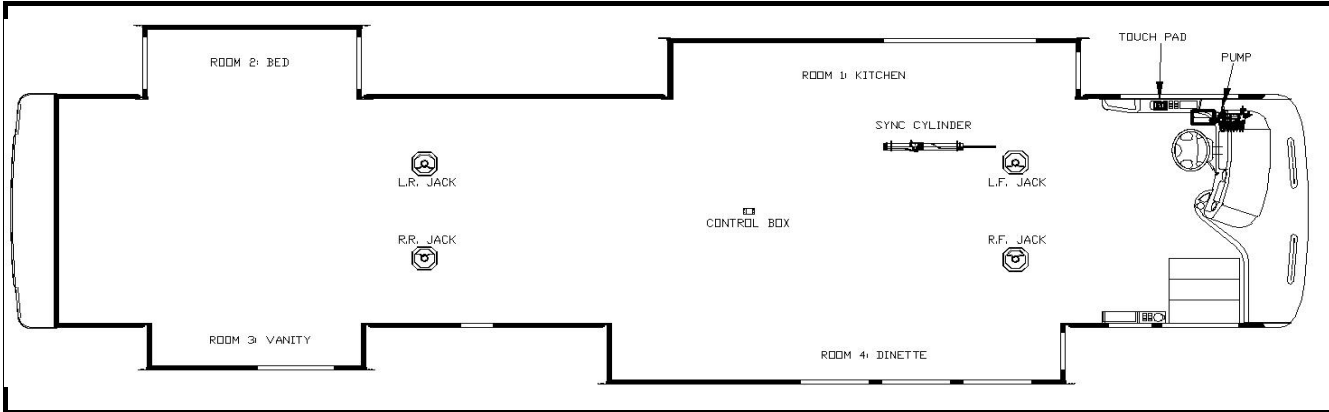

Notes:

- 1) Jacks mount to chassis brackets with the lowest holes of the jacks aligned with the lowest holes of the mounting brackets.
- 2) Level sensor attaches to bottom of structure; on the square tube the runs full length from axle to axle.
- 3) Hydraulic hose terminations for room #1 & #3 require 90 degree swivel elbows.
- 4) Hoses marked w90 will have the 90 deg fitting shipped loose.

Item, Length	Description / Location	Qty	Color	Vendor PN		
Kit	(Items listed below)	1		8508	Measuring from inside of firewall, this is the end location of the hydraulic hoses where they attach to the slide mechanism.	
Pump	8-Function, 4 Rooms & Jacks	1		7650BR		
Jack	17,000 lbs, 18" Stroke	4		7134		
Touch Pad	Located to the left of the drivers seat	1		2318		
Control Box	Attached to bottom of structure	1		2730		
Sync Cylinder	Mounted behind LP tank	2		7397		
Hose, 144	Pump to Jack, Left Front	2	Brown	2467		
Hose, 408	Pump to Jack, Left Rear	2	Orange	2484		
Hose, 144	Pump to Jack, Right Front	2	White	2467		
Hose, 408	Pump to Jack, Right Rear	1	Yellow	2484		
Hose, 108	Left Rear Jack, Right Rear Jack	1	Yel/ Ora	2464		
Hose, 168	Pump to synchronizing cylinder	2	Green	2469		Mounts to bracket on structure
Hose w90, 168	Sync cylinder to front slide, Room 1	2	Green	2469		115 / Drivers side
Hose w90, 168	Sync cylinder to rear slide, Room 1	2	Green	2469		205 / Drivers side
Slide Unit	Room 1 - 24" flush floor slide (angled)	2		7388		
Hose, 516	Pump to Room 2	2	Purple	2491		420 / Drivers Side
Slide Unit	Room 2 - 30" Bed slide (Lippert)	1		134998		
Hose w90, 516	Pump to Room 3	2	Gray	2491		404 / Passenger side
Slide Unit	Room 3 - 18" above floor slide	1		7135		
Hose, 168	Pump to synchronizing cylinder	2	Red	2469		Mounts to bracket on structure
Hose w90, 288	Sync cylinder to front slide, Room 4	2	Red	2478	115 / Passenger side	
Hose w90, 288	Sync cylinder to rear slide, Room 4	2	Red	2478	254 / Passenger side	
Slide Unit	Room 4 - 24" flush floor slide (angled)	2		7388		
Hose, 60	Pump to Generator Slide	2	Blue	2460	Inside Generator Tray	
Travel Clamp	(two per slide, except the bed slide)	6		HWH	N/A	
Options						
Revisions						

**38D SAHARA
EQUALIZER JACKS (FULLY AUTOMATIC)
STANDARD ON THIS UNIT**

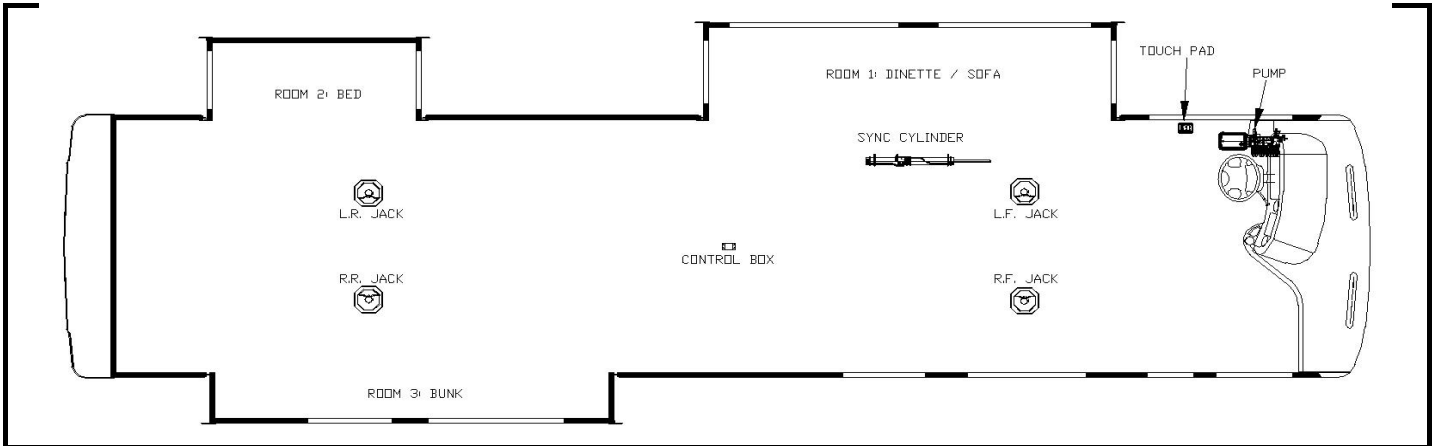

Notes:

- 1) Jacks mount to chassis brackets with the lowest holes of the jacks aligned with the lowest holes of the mounting brackets.
- 2) Level sensor attaches to bottom of structure; on lower hat section flanges or square tube.
- 3) Hydraulic hose terminations for room #1 & #3 require 90 degree swivel elbows.
- 4) Reference FM-3991 for a better visual of Room 1 hydraulic connections.
- 5) Hoses marked w90 will have the 90 deg fitting shipped loose.

Item, Length	Description / Location	Qty	Color	Vendor PN	
Kit	(Items listed below)	1		8347	
Pump	7-Function, 3 Rooms & Jacks	1		7319BR	
Jack	17,000 lbs, 18" Stroke	4		7134	
Touch Pad	Located to the left of the drivers seat	1		2318	
Control Box	Attached to bottom of structure	1		2730	
Sync Cylinder	Mounted behind LP tank	1		7387	
Hose, 132	Pump to Jack, Left Front	2	Brown	2466	
Hose, 384	Pump to Jack, Left Rear	2	Orange	2482	
Hose, 144	Pump to Jack, Right Front	2	White	2467	
Hose, 396	Pump to Jack, Right Rear	1	Yellow	2483	
Hose, 108	Left Rear Jack, Right Rear Jack	1	Yel/Ora	2464	
Hose, 144	Pump to synchronizing manifold	2	Green	2467	Mounts to bracket on structure
Hose w90, 168	Sync cylinder to front slide, Room 1	2	Green	2469	103 / Drivers side
Hose w90, 168	Sync cylinder to rear slide, Room 1	2	Green	2469	196 / Drivers side
	Pump to Room 1	N/A	Green		
Slide Unit	Room 1 - 36" flush floor slide	2		7523	
Hose, 444	Pump to Room 2	2	Purple	2487	325 / Drivers Side
Slide Unit	Room 2 - 30" Bed slide (Lippert)	1		134998	
Hose w90, 468	Pump to Room 3	2	Gray	2489	355 / Passenger Side
Slide Unit	Room 3 - 18" above floor slide	1		7135	
	Pump to Generator Slide	N/A			
Travel Clamp	(two per slide, dinette / sofa slide only)	2		HWH	N/A

Measuring from inside of firewall, this is the end location of the hydraulic hoses where they attach to the slide mechanism.

Options

Revisions

1	4-7-08, Corrected part number for 36" room, requires angled 36" in-floor mechanism #7523
2	4-23-08, Updated to match EQ's new way of plumbing jacks.

**38E SAHARA
EQUALIZER JACKS (FULLY AUTOMATIC)
STANDARD ON THIS UNIT**

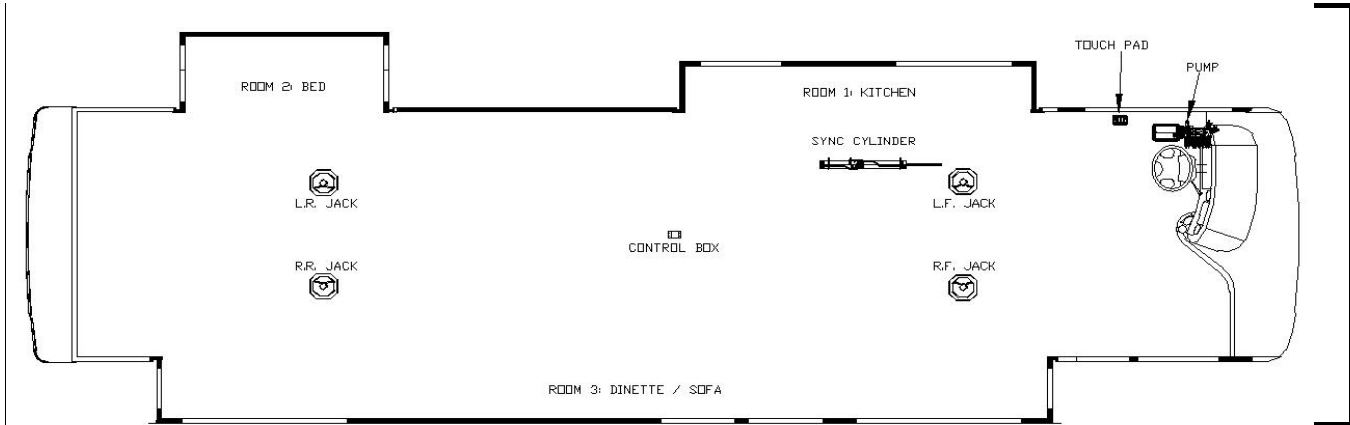

- 1) Jacks mount to chassis brackets with the lowest holes of the jacks aligned with the lowest holes of the mounting brackets.
- 2) Level sensor attaches to bottom of structure; on the square tube the runs full length from axle to axle.
- 3) Hydraulic hose terminations for room #2 & #3 require 90 degree swivel elbows.
- 4) Room #3 will have a non-powered slide mechanism in center of room
- 5) Hoses marked w90 will have the 90 deg fitting shipped loose.

Item, Length	Description / Location	Qty	Color	Vendor PN		
Kit	(Items listed below)	1		8350	Measuring from inside of firewall, this is the end location of the hydraulic hoses where they attach to the slide mechanism.	
Pump	7-Function, 3 Rooms & Jacks	1		7319BR		
Jack	17,000 lbs, 18" Stroke	4		7134		
Touch Pad	Located to the left of the drivers seat	1		2318		
Control Box	Attached to bottom of structure	1		2730		
Sync Cylinder	Mounted behind LP tank	1		7397		
Hose, 144	Pump to Jack, Left Front	2	Brown	2467		
Hose, 420	Pump to Jack, Left Rear	2	Orange	2485		
Hose, 144	Pump to Jack, Right Front	2	White	2467		
Hose, 420	Pump to Jack, Right Rear	1	Yellow	2485		
Hose, 108	Left Rear Jack, Right Rear Jack	1	Yel/ Ora	2464		
Hose, 144	Pump to synchronizing cylinder	2	Gray	2467		Mounts to bracket on structure
Hose w90, 432	Sync cylinder to front slide, Room 3	2	Gray	2486		103 / Passenger Side
Hose w90, 444	Sync cylinder to rear slide, Room 3	2	Gray	2487		350 / Passenger Side
Slide Unit	Room 3 - 24" flush floor slide (angled)	2		7388		
Slide Unit	Room 3 - 24" flush floor slide (angled)	1		7384	Slave	
Hose w90, 180	Pump to Room 1	2	Green	2470	146 / Drivers Side	
Slide Unit	Room 1 - 18" above floor slide	1		7135		
Hose, 516	Pump to Room 2	2	Purple	2491	345 / Drivers Side	
Slide Unit	Room 2 - 30" Bed slide (Lippert)	1		134998		
	Pump to Generator Slide	N/A			N/A	
Travel Clamp	(two per slide, except the bed slide)	4		HWH	N/A	
Options						
Revisions						
1	4-23-08, Updated to match EQ's new way of plumbing jacks.					

**40J SAHARA
EQUALIZER JACKS (FULLY AUTOMATIC)
STANDARD ON THIS UNIT**

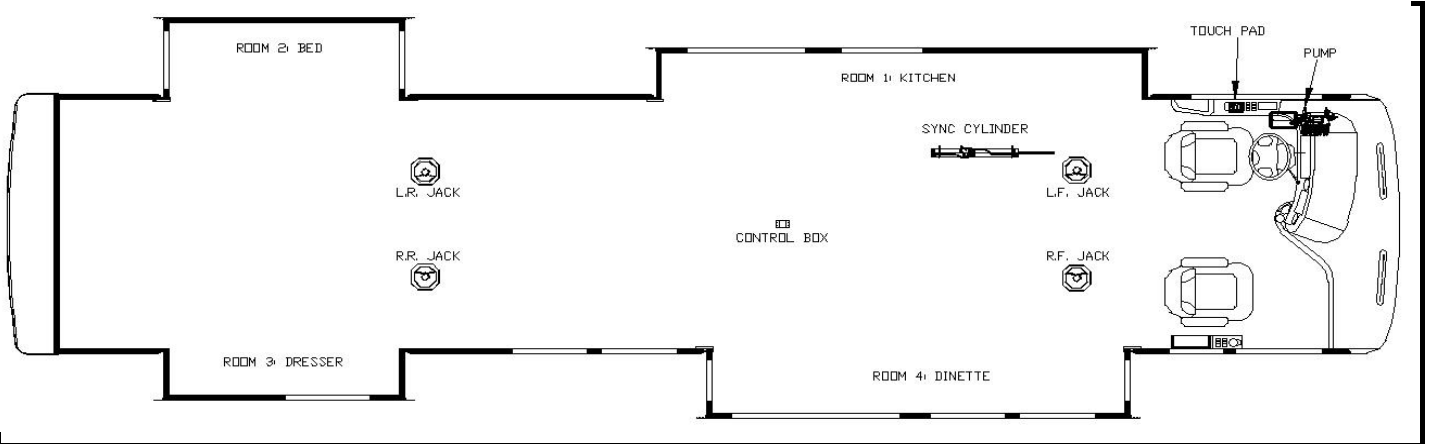

Notes:

- 1) Jacks mount to chassis brackets with the lowest holes of the jacks aligned with the lowest holes of the mounting brackets.
- 2) Level sensor attaches to bottom of structure; on the square tube the runs full length from axle to axle.
- 3) Hydraulic hose terminations for room #1, #3, & #4 require 90 degree swivel elbows.
- 4) Reference FM-3991 for a better visual of Room 4 hydraulic connections.
- 5) Hoses marked w90 will have the 90 deg fitting shipped loose.

Item, Length	Description / Location	Qty	Color	Vendor PN	
Kit	(Items listed below)	1		8421	
Pump	8-Function, 4 Rooms & Jacks	1		7302BR	
Jack	17,000 lbs, 18" Stroke	4		7134	
Touch Pad	Located to the left of the drivers seat	1		2318	
Control Box	Attached to bottom of structure	1		2730	
Sync Cylinder	Mounted behind LP tank	1		7397	
Sync Cylinder	Mounted behind LP tank	1		7511	
Hose, 144	Pump to Jack, Left Front	2	Brown	2467	
Hose, 408	Pump to Jack, Left Rear	2	Orange	2484	
Hose, 144	Pump to Jack, Right Front	2	White	2467	
Hose, 408	Pump to Jack, Right Rear	1	Yellow	2484	
Hose, 108	Left Rear Jack, Right Rear Jack	1	Yel/ Ora	2464	
Hose, 192	Pump to synchronizing cylinder	2	Green	2471	Mounts to bracket on structure
Hose w90, 144	Sync cylinder to front slide, Room 1	2	Green	2467	124 / Drivers side
Hose w90, 144	Sync cylinder to rear slide, Room 1	2	Green	2467	214 / Drivers side
Slide Unit	Room 1 - 18" above floor slide	2		7135	
Hose, 480	Pump to Room 2	2	Purple	2490	386 / Drivers Side
Slide Unit	Room 2 - 30" Bed slide (Lippert)	1		134998	
Hose w90, 480	Pump to Room 3	2	Gray	2490	365 / Passenger Side
Slide Unit	Room 3 - 18" above floor slide	1		7135	
Hoes, 192	Pump to synchronizing cylinder	2	Red	2471	Mounts to bracket on structure
Hose w90, 144	Sync cylinder to front slide, Room 4	2	Red	2467	124 / Passenger side
Hose w90, 144	Sync cylinder to rear slide, Room 4	2	Red	2467	214 / Passenger side
Slide Unit	Room 4 - 24" flush floor slide	2		7388	
	Pump to Generator Slide	N/A			N/A
Travel Clamp	(two per slide, except the bed slide)	6		HWH	N/A
Options					
Revisions					

Measuring from inside of firewall, this is the end location of the hydraulic hoses where they attach to the slide mechanism.

**40K SAHARA
EQUALIZER JACKS (FULLY AUTOMATIC)
STANDARD ON THIS UNIT**

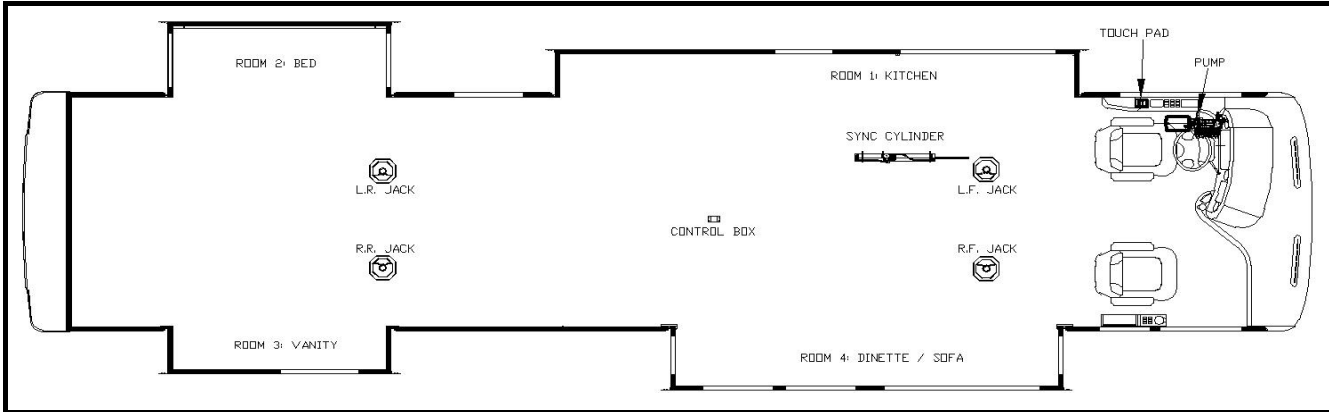

Notes:

- 1) Jacks mount to chassis brackets with the lowest holes of the jacks aligned with the lowest holes of the mounting brackets.
- 2) Level sensor attaches to bottom of structure; on the square tube the runs full length from axle to axle.
- 3) Hydraulic hose terminations for room #1, #3, & #4 require 90 degree swivel elbows.
- 4) Reference FM-3991 for a better visual of Room 4 hydraulic connections.
- 5) Hoses marked w90 will have the 90 deg fitting shipped loose.

Item, Length	Description / Location	Qty	Color	Vendor PN	
Kit	(Items listed below)	1		8418	
Pump	8-Function, 4 Rooms & Jacks	1		7302BR	
Jack	17,000 lbs, 18" Stroke	4		7134	
Touch Pad	Located to the left of the drivers seat	1		2318	
Control Box	Attached to bottom of structure	1		2730	
Sync Cylinder	Mounted behind LP tank	1		7397	
Sync Cylinder	Mounted behind LP tank	1		7511	
Hose, 144	Pump to Jack, Left Front	2	Brown	2467	
Hose, 408	Pump to Jack, Left Rear	2	Orange	2484	
Hose, 144	Pump to Jack, Right Front	2	White	2467	
Hose, 408	Pump to Jack, Right Rear	1	Yellow	2484	
Hose, 108	Left Rear Jack, Right Rear Jack	1	Yel/ Ora	2464	
Hose, 192	Pump to synchronizing cylinder	2	Green	2471	Mounts to bracket on structure
Hose w90, 144	Sync cylinder to front slide, Room 1	2	Green	2467	124 / Drivers side
Hose w90, 144	Sync cylinder to rear slide, Room 1	2	Green	2467	214 / Drivers side
Slide Unit	Room 1 - 18" above floor slide	2		7135	
Hose, 480	Pump to Room 2	2	Purple	2490	386 / Drivers Side
Slide Unit	Room 2 - 30" Bed slide (Lippert)	1		134998	
Hose w90, 480	Pump to Room 3	2	Gray	2490	365 / Passenger Side
Slide Unit	Room 3 - 18" above floor slide	1		7135	
Hose, 192	Pump to synchronizing cylinder	2	Red	2471	Mounts to bracket on structure
Hose w90, 144	Sync cylinder to front slide, Room 4	2	Red	2467	124 / Passenger side
Hose w90, 144	Sync cylinder to rear slide, Room 4	2	Red	2467	214 / Passenger side
Slide Unit	Room 4 - 24" flush floor slide	2		7388	
	Pump to Generator Slide	N/A			N/A
Travel Clamp	(two per slide, except the bed slide)	6		HWH	N/A
Options					
Revisions					

**42B SAHARA
EQUALIZER JACKS (FULLY AUTOMATIC)
STANDARD ON THIS UNIT**

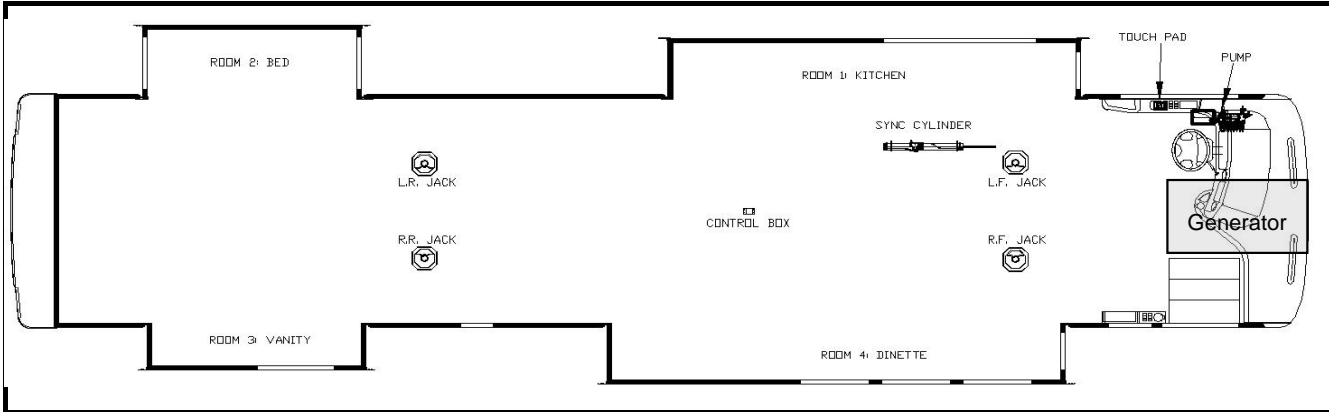

Notes:

- 1) Jacks mount to chassis brackets with the lowest holes of the jacks aligned with the lowest holes of the mounting brackets.
- 2) Level sensor attaches to bottom of structure; on the square tube the runs full length from axle to axle.
- 3) Hydraulic hose terminations for room #1 & #3 require 90 degree swivel elbows.
- 4) Hoses marked w90 will have the 90 deg fitting shipped loose.

Item, Length	Description / Location	Qty	Color	Vendor PN		
Kit	(Items listed below)	1		8508		
Pump	9-Function, 4 Rooms & Jacks	1		7650BR	Measuring from inside of firewall, this is the end location of the hydraulic hoses where they attach to the slide mechanism.	
Jack	17,000 lbs, 18" Stroke	4		7134		
Touch Pad	Located to the left of the drivers seat	1		2318		
Control Box	Attached to bottom of structure	1		2730		
Sync Cylinder	Mounted behind LP tank	2		7397		
Hose, 144	Pump to Jack, Left Front	2	Brown	2467		
Hose, 408	Pump to Jack, Left Rear	2	Orange	2484		
Hose, 144	Pump to Jack, Right Front	2	White	2467		
Hose, 408	Pump to Jack, Right Rear	1	Yellow	2484		
Hose, 108	Left Rear Jack, Right Rear Jack	1	Yel/ Ora	2464		
Hose, 168	Pump to synchronizing cylinder	2	Green	2469		Mounts to bracket on structure
Hose w90, 168	Sync cylinder to front slide, Room 1	2	Green	2469		115 / Drivers side
Hose w90, 168	Sync cylinder to rear slide, Room 1	2	Green	2469	205 / Drivers side	
Slide Unit	Room 1 - 24" flush floor slide (angled)	2		7388		
Hose, 516	Pump to Room 2	2	Purple	2491	420 / Drivers Side	
Slide Unit	Room 2 - 30" Bed slide (Lippert)	1		134998		
Hose w90, 516	Pump to Room 3	2	Gray	2491	404 / Passenger side	
Slide Unit	Room 3 - 18" above floor slide	1		7135		
Hose, 168	Pump to synchronizing cylinder	2	Red	2469	Mounts to bracket on structure	
Hose w90, 288	Sync cylinder to front slide, Room 4	2	Red	2478	115 / Passenger side	
Hose w90, 288	Sync cylinder to rear slide, Room 4	2	Red	2478	254 / Passenger side	
Slide Unit	Room 4 - 24" flush floor slide (angled)	2		7388		
Hose, 60	Pump to Generator Slide	2	Blue	2460	Inside generator tray	
Travel Clamp	(two per slide, except the bed slide)	6		HWH	N/A	

Options

Revisions

1	4-23-08, Updated to match EQ's new way of plumbing jacks.

**42C SAHARA
EQUALIZER JACKS (FULLY AUTOMATIC)
STANDARD ON THIS UNIT**

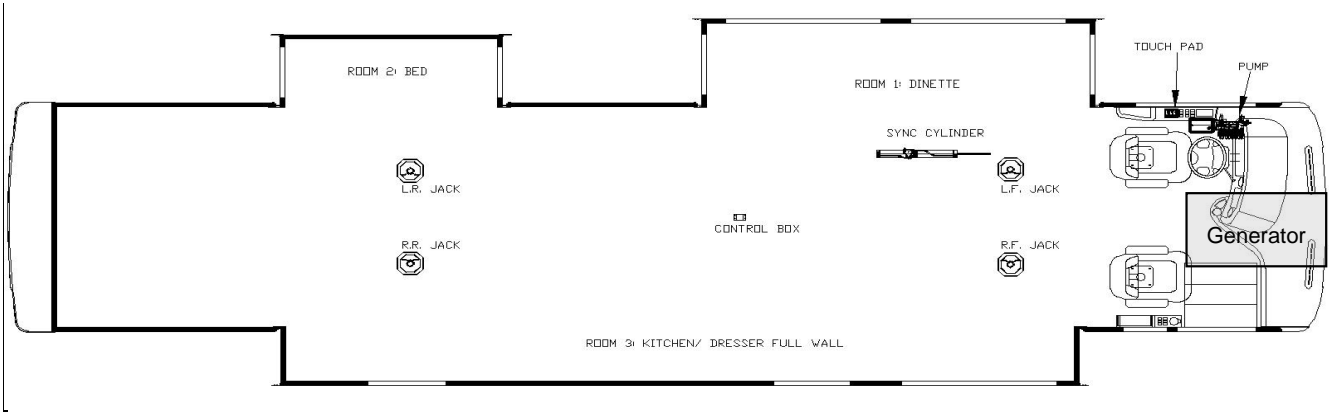

- Notes:**
- 1) Jacks mount to chassis brackets with the lowest holes of the jacks aligned with the lowest holes of the mounting brackets.
 - 2) Level sensor attaches to bottom of structure; on the square tube the runs full length from axle to axle.
 - 3) Hydraulic hose terminations for room #1 & #3 require 90 degree swivel elbows.
 - 4) Hoses marked w90 will have the 90 deg fitting shipped loose.

Item, Length	Description / Location	Qty	Color	Vendor PN		
Kit	(Items listed below)	1		8526		
Pump	8-Function, 3 Rooms & Jacks	1		7302BR		
Jack	17,000 lbs, 18" Stroke	4		7134		
Touch Pad	Located to the left of the drivers seat	1		2318	Measuring from inside of firewall, this is the end location of the hydraulic hoses where they attach to the slide mechanism.	
Control Box	Attached to bottom of structure	1		2730		
Sync Cylinder	Mounted behind LP tank	1		7387		
Sync Cylinder	Mounted behind LP tank	1		7397		
Hose, 144	Pump to Jack, Left Front	2	Brown	2467		
Hose, 408	Pump to Jack, Left Rear	2	Orange	2484		
Hose, 144	Pump to Jack, Right Front	2	White	2467		
Hose, 408	Pump to Jack, Right Rear	1	Yellow	2484		
Hose, 108	Left Rear Jack, Right Rear Jack	1	Yel/ Ora	2464		
Hose, 168	Pump to synchronizing cylinder	2	Green	2469		Mounts to bracket on structure
Hose w90, 168	Sync cylinder to front slide, Room 1	2	Green	2469		115 / Drivers side
Hose w90, 168	Sync cylinder to rear slide, Room 1	2	Green	2469		205 / Drivers side
Slide Unit	Room 1 - 36" flush floor slide (angled)	2		7523		
Hose, 468	Pump to Room 2	2	Purple	2489	402 / Drivers Side	
Slide Unit	Room 2 - 30" Bed slide (Lippert)	1		134998		
Hose, 168	Pump to synchronizing cylinder	2	Grey	2469	Mounts to bracket on structure	
Hose w90, 324	Sync cylinder to front slide, Room 3	2	Grey	2480	115 / Passenger side	
Hose w90, 324	Sync cylinder to rear slide, Room 3	2	Grey	2480	300 / Passenger side	
Slide Unit	Room 3 - 24" above floor slide	2		7369		
Slide Unit	Room 3 - 24" above floor slide	1		7662	Slave	
Hose, 60	Pump to Generator Slide	2	Red	2460	Inside generator tray	
Travel Clamp	(two per slide, except the bed slide)	4		HWH	N/A	

Options					

Revisions					

Montecito Travel Lock Harnesses

38D

Room 1-6766
Room 2-none
Room 3-none

38E

Room 1-6749
Room 2-none
Room 3-6750

40J

Room 1-6822
Room 2-none
Room 3-6823
Room 4-6821

42B

Room 1-6774
Room 2-none
Room 3-6775
Room 4-6776

42C

Room 1-6774
Room 2-none
Room 3-6750

42D

Room 1-6776
Room 2-none
Room 3-6897
Room 4-6776

36" FOUR WINDS SLIDE WEIGHT REMOVAL OPTIONS

OUTER FRAME	Weight	Savings
Current style	46.5 lbs	
With ¼" back plate and cut outs	36.9 lbs	9.6 lbs
11 ga. with ¼" back plate and cut outs	33.3 lbs	13.2 lbs
12 ga. with ¼" back plate and cut outs	29.8 lbs	16.7 lbs
INNER TUBE ASSEMBLY	Weight	Savings
Current Style	50 lbs	
Current with cut outs	45.6 lbs	4.4 lbs
1 ¼ x 3 Tube with cut outs	34.6 lbs	15.4 lbs
1 ½ x 2 ½ Tube with cut outs	34.1 lbs	15.9 lbs

2006 FOUR WINDS SLIDE REFERENCE

FUNMOVER

39C SOFA 7164 SLIDE ASSBLY 36" FOUR WINDS

39D SOFA/DIN. 7164 SLIDE ASSBLY 36" FOUR WINDS

SUPER C

32B SOFA/DIN 7164B SLIDE ASSBLY 36" FOUR WINDS

35B SOFA/DIN. 7164B SLIDE ASSBLY 36" FOUR WINDS
REAR ROOM-Electric by others

33K ALL SLIDES ARE ELECTRIC

34G ALL SLIDES ARE ELECTRIC

HURRICANE

30F SOFA/DIN 7164 SLIDE ASSBLY 36" FOUR WINDS

31D ALL SLIDES ARE ELECTRIC

31H ALL SLIDES ARE ELECTRIC

32R SOFA/DIN. 7164 SLIDE ASSBLY 36" FOUR WINDS
BED 7303-CYLINDER-BED SLIDE-FOUR WINDS
(SLIDE BUILT BY POWER GEAR)

33H SOFA/DIN 7164 SLIDE ASSBLY 36" FOUR WINDS

34N SOFA/DIN. 7164 SLIDE ASSBLY 36" FOUR WINDS
KITCHEN 7135 SLIDE ASSBLY 18" FOUR WINDS
BED 7303-CYLINDER-BED SLIDE-FOUR WINDS
(SLIDE BUILT BY POWER GEAR)

WINDSPORT

32R

SOFA/DIN 7164D SLIDE ASSBLY 36" FOUR WINDS (2 REQ'D WITH
7351 SYNC CYL)
BED 7303-CYLINDER-BED SLIDE-FOUR WINDS
(SLIDE BUILT BY POWER GEAR)

34A

SOFA/DIN 7164D SLIDE ASSBLY 36" FOUR WINDS (2 REQ'D WITH
7351 SYNC CYL)
BED 7303-CYLINDER-BED SLIDE-FOUR WINDS
(SLIDE BUILT BY POWER GEAR)

34N

SOFA/DIN 7164D SLIDE ASSBLY 36" FOUR WINDS (2 REQ'D WITH
7351 SYNC CYL)
KITCHEN 7135 SLIDE ASSBLY 18" FOUR WINDS
BED 7303-CYLINDER-BED SLIDE-FOUR WINDS
(SLIDE BUILT BY POWER GEAR)

35W

SOFA/DIN 7164D SLIDE ASSBLY 36" FOUR WINDS (2 REQ'D WITH
7351 SYNC CYL)

36A

SOFA/DIN 7164D SLIDE ASSBLY 36" FOUR WINDS (2 REQ'D WITH
7351 SYNC CYL)
BED 7303-CYLINDER-BED SLIDE-FOUR WINDS
(SLIDE BUILT BY POWER GEAR)

36E

SOFA/DIN 7164D SLIDE ASSBLY 36" FOUR WINDS (2 REQ'D WITH
7351 SYNC CYL)
WARDROBE 7135 SLIDE ASSBLY 18" FOUR WINDS
BED 7303-CYLINDER-BED SLIDE-FOUR WINDS
(SLIDE BUILT BY POWER GEAR)

36K

SOFA/DIN 7164D SLIDE ASSBLY 36" FOUR WINDS (2 REQ'D WITH
7351 SYNC CYL)
WARDROBE 7135 SLIDE ASSBLY 18" FOUR WINDS
BED 7303-CYLINDER-BED SLIDE-FOUR WINDS
(SLIDE BUILT BY POWER GEAR)

36Z

SOFA/DIN 7164D SLIDE ASSBLY 36" FOUR WINDS (2 REQ'D WITH
7351 SYNC CYL)
BED 7303-CYLINDER-BED SLIDE-FOUR WINDS
(SLIDE BUILT BY POWER GEAR)

MAGELLAN

34N

SOFA/DIN 7164D SLIDE ASSBLY 36" FOUR WINDS (2 REQ'D WITH
7351 SYNC CYL)
KITCHEN 7135 SLIDE ASSBLY 18" FOUR WINDS
BED 7303-CYLINDER-BED SLIDE-FOUR WINDS
(SLIDE BUILT BY POWER GEAR)

36A

SOFA/DIN 7164D SLIDE ASSBLY 36" FOUR WINDS (2 REQ'D WITH
7351 SYNC CYL)
BED 7303-CYLINDER-BED SLIDE-FOUR WINDS
(SLIDE BUILT BY POWER GEAR)

36E

SOFA/DIN 7164D SLIDE ASSBLY 36" FOUR WINDS (2 REQ'D WITH
7351 SYNC CYL)
WARDROBE 7135 SLIDE ASSBLY 18" FOUR WINDS
BED 7303-CYLINDER-BED SLIDE-FOUR WINDS
(SLIDE BUILT BY POWER GEAR)

36K

SOFA/DIN 7164D SLIDE ASSBLY 36" FOUR WINDS (2 REQ'D WITH
7351 SYNC CYL)
WARDROBE 7135 SLIDE ASSBLY 18" FOUR WINDS
BED 7303-CYLINDER-BED SLIDE-FOUR WINDS
(SLIDE BUILT BY POWER GEAR)

36Z

SOFA/DIN 7164D SLIDE ASSBLY 36" FOUR WINDS (2 REQ'D WITH
7351 SYNC CYL)
BED 7303-CYLINDER-BED SLIDE-FOUR WINDS
(SLIDE BUILT BY POWER GEAR)

38E

SOFA/DIN	7164D SLIDE ASSBLY 36" FOUR WINDS (2 REQ'D WITH 7351 SYNC CYL)
VANITY	7135 SLIDE ASSBLY 18" FOUR WINDS
BED	7303-CYLINDER-BED SLIDE-FOUR WINDS (SLIDE BUILT BY POWER GEAR)
KITCHEN	7135 SLIDE ASSBLY 18" FOUR WINDS

VALENCIA

36A

SOFA/DIN	7164D SLIDE ASSBLY 36" FOUR WINDS (2 REQ'D WITH 7351 SYNC CYL)
BED	7303-CYLINDER-BED SLIDE-FOUR WINDS (SLIDE BUILT BY POWER GEAR)

37A

SOFA/DIN	7164D SLIDE ASSBLY 36" FOUR WINDS (2 REQ'D WITH 7351 SYNC CYL)
BED	7303-CYLINDER-BED SLIDE-FOUR WINDS (SLIDE BUILT BY POWER GEAR)
VANITY	7135 SLIDE ASSBLY 18" FOUR WINDS

38C

SOFA/DIN	7164D SLIDE ASSBLY 36" FOUR WINDS (2 REQ'D WITH 7351 SYNC CYL)
BED	7303-CYLINDER-BED SLIDE-FOUR WINDS (SLIDE BUILT BY POWER GEAR)
VANITY	7135 SLIDE ASSBLY 18" FOUR WINDS
KITCHEN	7135 SLIDE ASSBLY 18" FOUR WINDS

PRESIDIO

39A

SOFA/DIN	7164D SLIDE ASSBLY 36" FOUR WINDS (2 REQ'D WITH 7351 SYNC CYL)
BED	7303-CYLINDER-BED SLIDE-FOUR WINDS (SLIDE BUILT BY POWER GEAR)
VANITY	7135 SLIDE ASSBLY 18" FOUR WINDS
KITCHEN	7135 SLIDE ASSBLY 18" FOUR WINDS

39B

SOFA/DIN	7164D SLIDE ASSBLY 36" FOUR WINDS (2 REQ'D WITH 7351 SYNC CYL)
BED	7303-CYLINDER-BED SLIDE-FOUR WINDS (SLIDE BUILT BY POWER GEAR)
VANITY	7135 SLIDE ASSBLY 18" FOUR WINDS
KITCHEN	7135 SLIDE ASSBLY 18" FOUR WINDS

39C

SOFA/DIN	7164D SLIDE ASSBLY 36" FOUR WINDS (2 REQ'D WITH 7351 SYNC CYL)
VANITY	7135 SLIDE ASSBLY 18" FOUR WINDS
BED	7303-CYLINDER-BED SLIDE-FOUR WINDS (SLIDE BUILT BY POWER GEAR)
KITCHEN	7135 SLIDE ASSBLY 18" FOUR WINDS

39D

KITCHEN	7135 SLIDE ASSBLY 18" FOUR WINDS
BED	7303-CYLINDER-BED SLIDE-FOUR WINDS (SLIDE BUILT BY POWER GEAR)
VANITY	7135 SLIDE ASSBLY 18" FOUR WINDS
SOFA/DIN	7164D SLIDE ASSBLY 36" FOUR WINDS (2 REQ'D WITH 7351 SYNC CYL)

2009 FOUR WINDS PROJECTED MODEL LINE UP

MANDALAY

40G-8359
 43A-8360
 43C-8377
 43D-8419

PRESIDIO

38D-8347
 38E-8350
 40J-New Model
 40K-8418
 42A-8373
 42B-8379

MAGELLAN

34B-8323
 34U-New Model
 36E-8309
 36F-8366
 36R-8342
 36Z-8307

WINDSPORT

30Q-8252
 31D-8252
 32E-8252
 32R-8308
 33T-8381
 34B-8323
 34U-New Model
 34Y-8365
 36E-8309
 36F-8366
 36R-8342
 36Z-8307

HURRICANE

30Q-8252
 31D-8252
 32E-8252
 33H-8270
 33T-8381
 34B-8323
 34N-8269
 34Y-8365

SUPER "C"

32B-8264
 33K-8274
 34G-8275
 34H-8341
 35B-8264
 36A-New Model
 36B-New Model

FUN MOVER

31D-8251
 35D-8251
 34Y-8365
 42C-8250/8253
 42D-8250/8253

Note:

Full 2009 will be on April 8, 2008 release for diesel units, and April 21, 2009 for gas units. Units listed as New Model have not been given to us yet to build systems for. On the Super "C" all of the existing units will be obsolete somewhere around 50 units into the new model year, and the only units that will have our stuff on them are the new ones.

38B Slide Components (auto-option)

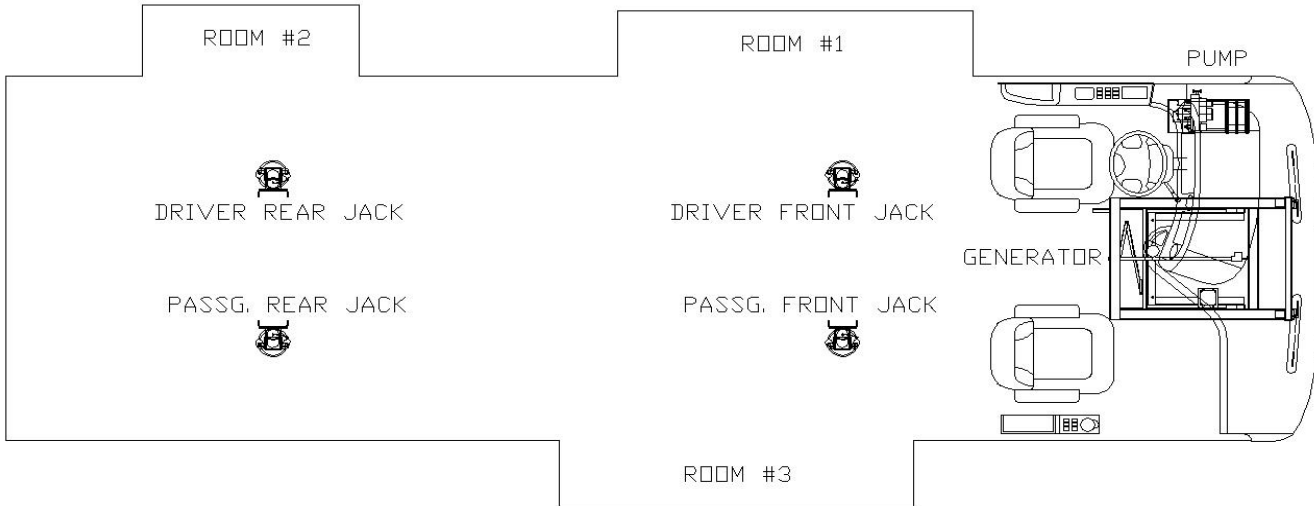

Leveling System = AP33439

Hose Kit = AP33457

Description:	Room #1	Room #2	Room #3	Room #4	Generator	Front Jacks	Rear Jacks	Total:
Length: (feet)	FM-3090	39	16	0	5	11	31	102

Notes: The hose kit will include the following: touch panel w/ 12' multiplex harness that connects to pump, 12K lb front and rear jacks with cross ties, power unit with valving for 3 room extensions and one generator extension, automatic leveling sensors, & a sync cylinder

HWH Electrical Harnesses

Switch Sensor Harness:

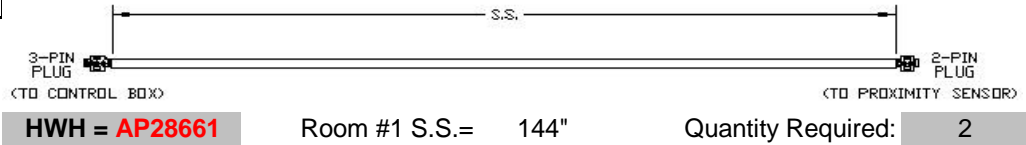

Lockdown Arms:

HWH Part #	Dimension (inches)				Quantity	Room #
	A	B	C	D		
AP29304	100	264	10	n/a	1	1
AP30496	n/a	n/a	n/a	120	1	1
AP29469	180	340	19	n/a	1	3

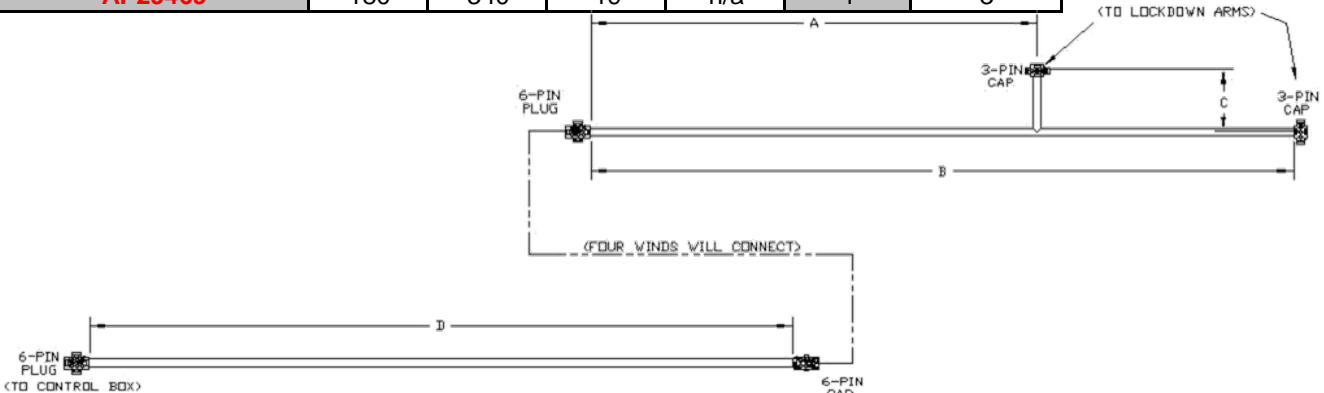

- Harness connecting lockdown arm control module for Room #1 to pump = 160"
- Harness connecting lockdown arm control module for Room #2 to pump = no lock-arms
- Harness connecting lockdown arm control module for Room #3 to pump = 250"
- Harness connecting lockdown arm control module for Room #4 to pump = n/a
- Harness connecting lockdown arm control module for Room #1 to panel = 432"
- Harness connecting lockdown arm control module for Room #3 to panel = 672"

AP29292
AP29288

Harness from Dewald bedside to HWH pump: 475"
(used with room #2)

Other Parts

<u>Description:</u>	<u>Print #</u>	<u>Quan.</u>	<u>Vendor</u>	<u>Vendor #</u>
36" Slide Mechanism	n/a	2	HWH	AP25893
18" Slide Mechanism	n/a	1	HWH	AP26810
Hardware Kit	FM-1806	1	HWH	AP27968
Angle, Room Mount (short)	FM-1806	1	HWH	AP27499
Angle, Room Mount (long)	FM-1806	1	HWH	P26223
Cylinder, Bed Slide	n/a	1	HWH	AP27411
Sync Cylinder	n/a	1	HWH	AP29839
Nylon Strip (beveled)	n/a	3	HWH	P14291
Bed Slide Mechanism	FM-2014	1	Power Gear	59-754-0100

- Revisions:**
1. Released to HWH and production NS, 4-22-04
 2. Added HWH part number for leveling system NS, 5-14-04
 3. Added "Harness from Dewald bedslide to HWH pump" for room #2 NS, 6-10-04
 4. Added semi-auto leveling as the standard for Mandalay (two possible kits for every coach now)
 5. Changed hose length for room #1 to reference FM-3090 NS, 7-2-04
 6. Changed multiplex harness length from 8' to 12' for touch pad NS, 7-8-04
 7. Added the HWH hose kit part number NS, 7-13-04

40B Slide Components (auto-option)

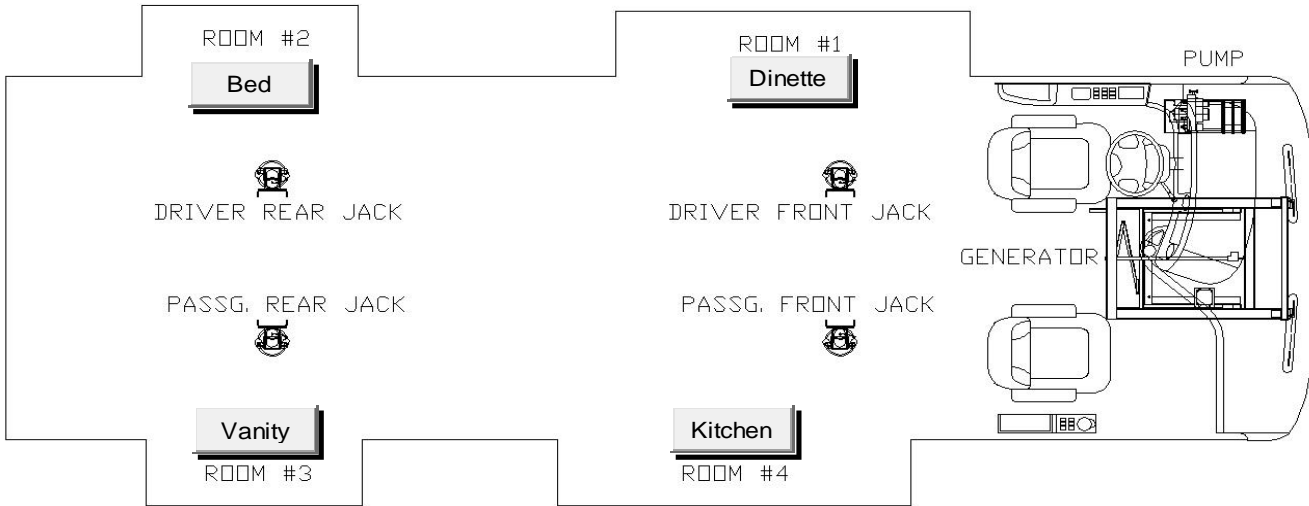

Leveling System = **AP33352**

Hose Kit = **AP33444**

Description:	Room #1	Room #2	Room #3	Room #4	Generator	Front Jacks	Rear Jacks	Total:
Length: (feet)	FM-3090	41	36	16	5	11	33	142

Notes: The hose kit will include the following: touch panel w/ 12' multiplex harness that connects to pump, 12K lb front and rear jacks with cross ties, power unit with valving for 4 room extensions and one generator extension, automatic leveling sensors, & a sync cylinder

HWH Electrical Harnesses

Switch Sensor Harness:

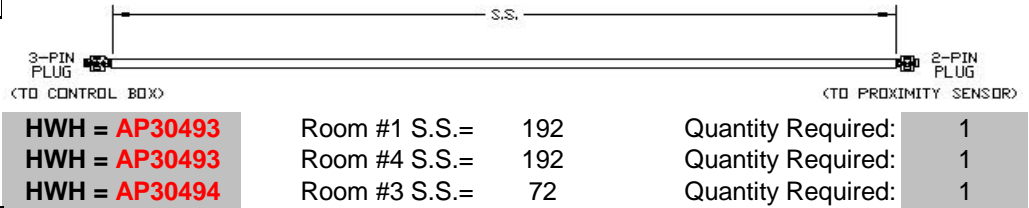

Lockdown Arms:

HWH Part #	Dimension (inches)				Quantity	Room #
	A	B	C	D		
AP34480	6	192	96	n/a	1	1
AP30495	n/a	n/a	n/a	126	2	1 & 3
AP29469	180	340	19	n/a	1	4
AP29305	63	159	13	n/a	1	3

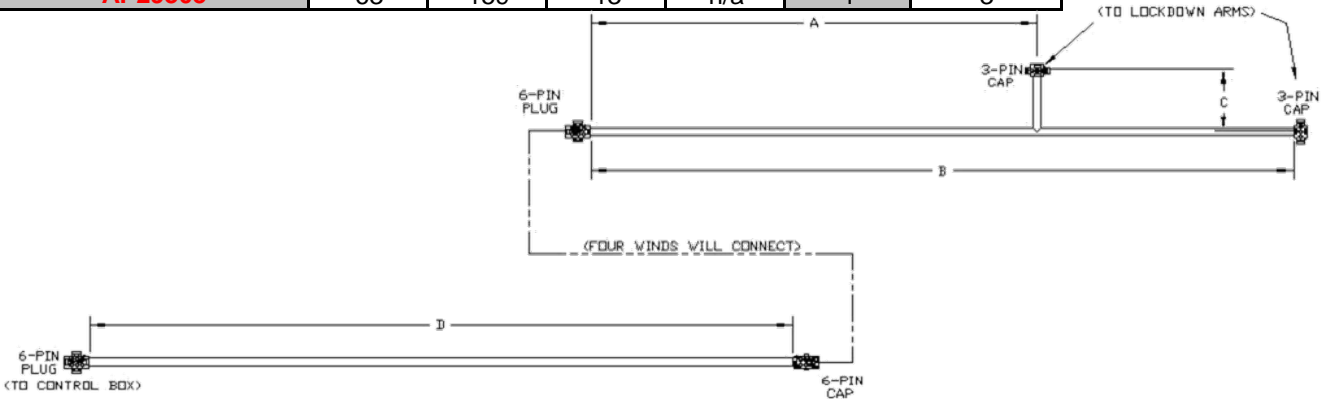

2005 and 2006 40B

Harness connecting lockdown arm control module for Room #1 to pump = 160"
 Harness connecting lockdown arm control module for Room #2 to pump = no lock-arms
 Harness connecting lockdown arm control module for Room #3 to pump = 430"
 Harness connecting lockdown arm control module for Room #4 to pump = 250"
 Harness connecting lockdown arm control module for Room #1 to panel = 432" **AP29292**
 Harness connecting lockdown arm control module for Room #3 & #4 to panel = 480" **AP29288**

Harness from Dewald bedslide to HWH pump: 500"
 (used with room #2)

Other Parts

<u>Description:</u>	<u>Print #</u>	<u>Quan.</u>	<u>Vendor</u>	<u>Vendor #</u>
36" Slide Mechanism	n/a	2	HWH	AP25893
18" Slide Mechanism	n/a	2	HWH	AP26810
Hardware Kit	FM-2158	4	HWH	AP27968
Angle, Room Mount (short)	FM-1806	1	HWH	AP27499
Angle, Room Mount (long)	FM-1806	1	HWH	P26223
Cylinder, Bed Slide	n/a	1	HWH	AP27411
Sync Cylinder	n/a	1	HWH	AP29839
Nylon Strip (beveled)	n/a	3.5	HWH	P14291
Bed Slide Mechanism	FM-2014	1	Power Gear	
Angle, Room Mount (short)	FM-2158	1	HWH	P29809
Angle, Room Mount (long)	FM-2158	1	HWH	AP29804

Revisions:

- Released to HWH and production NS, 4-22-04
- Added HWH part number for leveling system NS, 5-14-04
- Added "Harness from Dewald bedslide to HWH pump" for room #2 NS, 6-10-04
- Added semi-auto leveling as the standard for Mandalay (two possible kits for every coach now)
- Changed hose length for room #1 to reference FM-3090 NS, 7-2-04
- Changed multiplex harness length from 8' to 12' for touch pad NS, 7-8-04
- Added the HWH hose kit part number NS, 7-13-04
- Added the harnesses that connect the lockdown control module to the panel NS, 7-26-04
- Changed dinette slide switch sensor harness (room #1) ECN #3140 NS 9-27-04
- Updated room #1 with 192" harness per HWH NS,10-11-04
- Updated per ECN #3429, all dinette slide outs take same lock down arm harness NS, 4-22-05
- Modified hose length from sync cylinder to pump; see FM-3090-1 (ECN #3477) NS, 6-2-05
- Changed length of AP29288, was 672" now 480" (ECN #3619) NS, 8-24-05

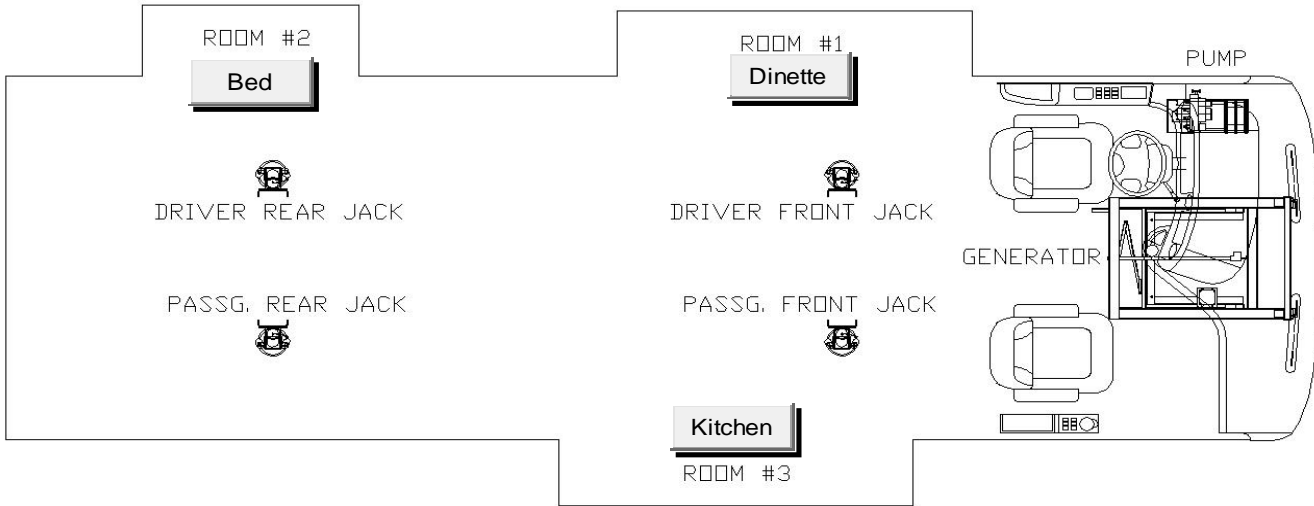

Leveling System = AP33441

Hose Kit = AP33458

Description:	Room #1	Room #2	Room #3	Room #4	Generator	Front Jacks	Rear Jacks	Total:
Length: (feet)	FM-3090	37	16	0	5	11	33	102

Notes: The hose kit will include the following: touch panel w/ 12' multiplex harness that connects to pump, 12K lb front and rear jacks with cross ties, power unit with valving for 3 room extensions and one generator extension, automatic leveling sensors, & a sync cylinder

HWH Electrical Harnesses

Switch Sensor Harness:

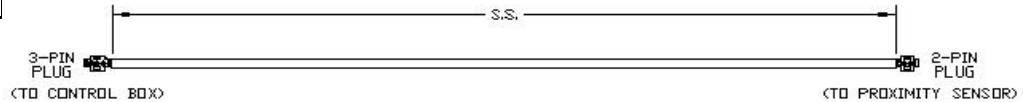

HWH = AP30493	Room #1 S.S. =	192	Quantity Required:	2
HWH = AP28661	Room #3 S.S. =	144	Quantity Required:	2

Lockdown Arms:

HWH Part #	Dimension (inches)				Quantity	Room #
	A	B	C	D		
AP34480	6	192	96	n/a	1	1
AP30495	n/a	n/a	n/a	126	1	1
AP29469	180	340	19	n/a	1	3

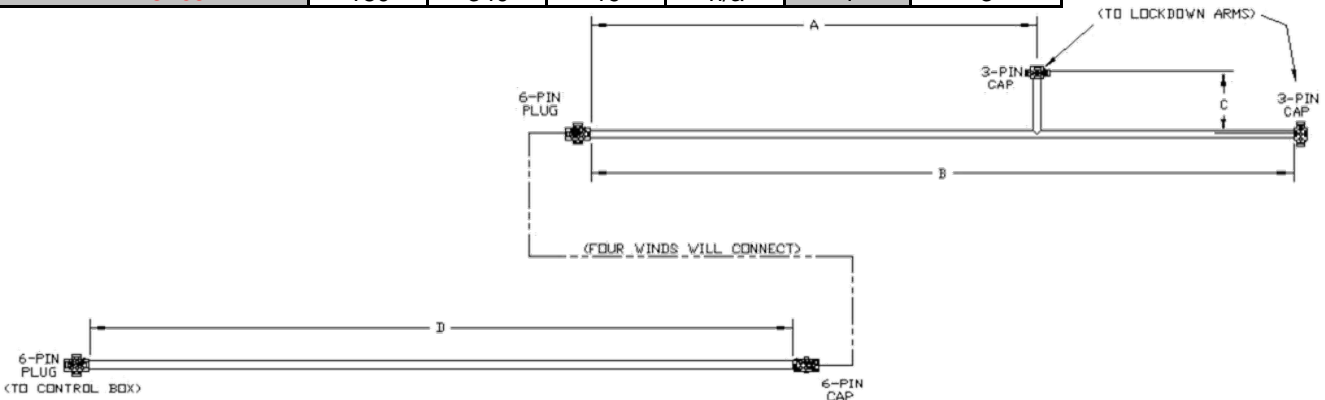

2005 and 2006 40D

Harness connecting lockdown arm control module for Room #1 to pump =	160"	
Harness connecting lockdown arm control module for Room #2 to pump =	no lock-arms	
Harness connecting lockdown arm control module for Room #3 to pump =	250"	
Harness connecting lockdown arm control module for Room #4 to pump =	n/a	
Harness connecting lockdown arm control module for Room #1 to panel =	432"	AP29292
Harness connecting lockdown arm control module for Room #3 to panel =	480"	AP29288

Harness from Dewald bedslide to HWH pump: 450"
 (used with room #2)

Other Parts

<u>Description:</u>	<u>Print #</u>	<u>Quan.</u>	<u>Vendor</u>	<u>Vendor #</u>
36" Slide Mechanism	n/a	2	HWH	AP25893
18" Slide Mechanism	n/a	1	HWH	AP26810
Hardware Kit	FM-2158	4	HWH	AP27968
Angle, Room Mount (long)	FM-2158	1	HWH	AP29804
Angle, Room Mount (long)	FM-1806	1	HWH	P26223
Cylinder, Bed Slide	n/a	1	HWH	AP27411
Sync Cylinder	n/a	1	HWH	AP29839
Nylon Strip (beveled)	n/a	2	HWH	P14291
Bed Slide Mechanism	FM-1871	1	Power Gear	
Angle, Room Mount (short)	FM-2158	1	HWH	P29809

- Revisions:**
- Released to HWH and production NS, 4-22-04
 - Added HWH part number for leveling system & corrected bed slide mechanism part number NS, 5-14-04
 - Added "Harness from Dewald bedslide to HWH pump" for room #2 NS, 6-10-04
 - Added semi-auto leveling as the standard for Mandalay (two possible kits for every coach now)
 - Changed hose length for room #1 to reference FM-3090 NS, 7-2-04
 - Changed multiplex harness length from 8' to 12' for touch pad NS, 7-8-04
 - Added the HWH hose kit part number NS, 7-13-04
 - Added the harnesses that connect the lockdown control module to the panel NS, 7-26-04
 - Changed dinette slide switch sensor harness (room #1) ECN #3140 NS 9-27-04
 - Updated room #1 with 192" harness per HWH NS, 10-11-04
 - Updated per ECN #3429, all dinette slide outs take same lock down arm harness NS, 4-22-05
 - Modified hose length from sync cylinder to pump; see FM-3090-1 (ECN #3477) NS, 6-2-05
 - Changed length of AP29288, was 672" now 480" (ECN #3619) NS, 8-24-05

40E & 40G Slide Components (auto-option)

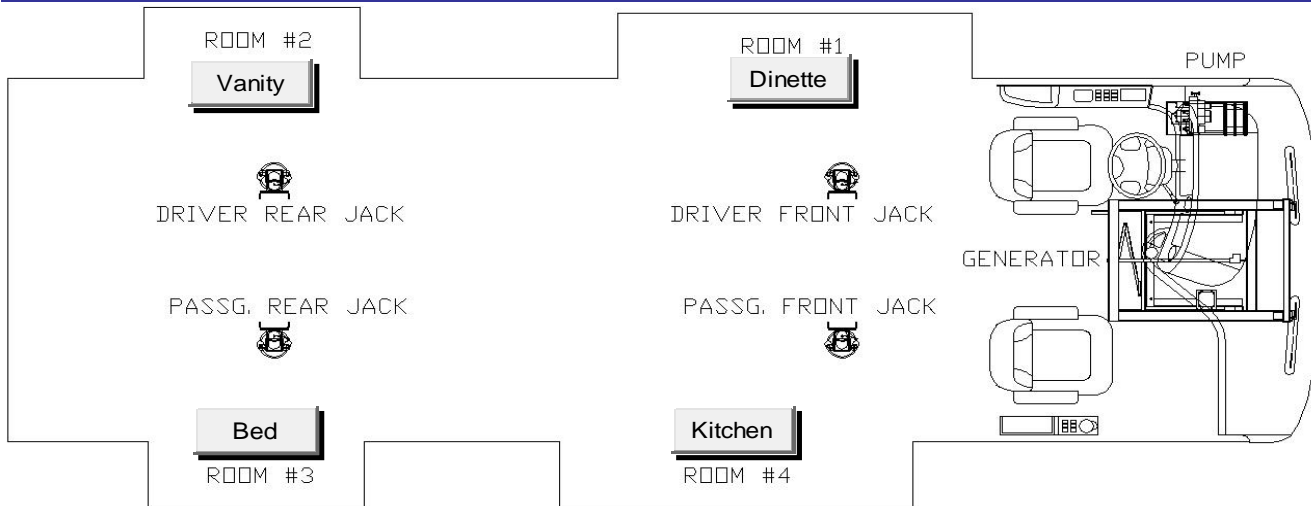

Leveling System = AP33276

Hose Kit = AP33443

Description:	Room #1	Room #2	Room #3	Room #4	Generator	Front Jacks	Rear Jacks	Total:
Length: (feet)	FM-3090	36	41	16	5	11	33	142

Notes: The hose kit will include the following: touch panel w/ 12' multiplex harness that connects to pump, 12K lb front and rear jacks with cross ties, power unit with valving for 4 room extensions and one generator extension, automatic leveling sensors, & a sync cylinder

HWH Electrical Harnesses

Switch Sensor Harness:

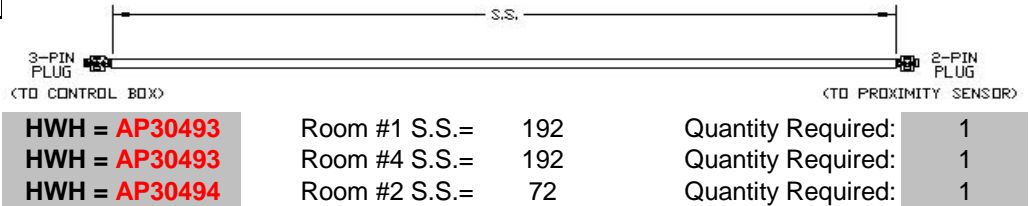

Lockdown Arms:

HWH Part #	Dimension (inches)				Quantity	Room #
	A	B	C	D		
AP34480	6	192	96	n/a	1	1
AP30495	n/a	n/a	n/a	126	2	1 & 2
AP29469	180	340	19	n/a	1	4
AP29305	63	159	13	n/a	1	2

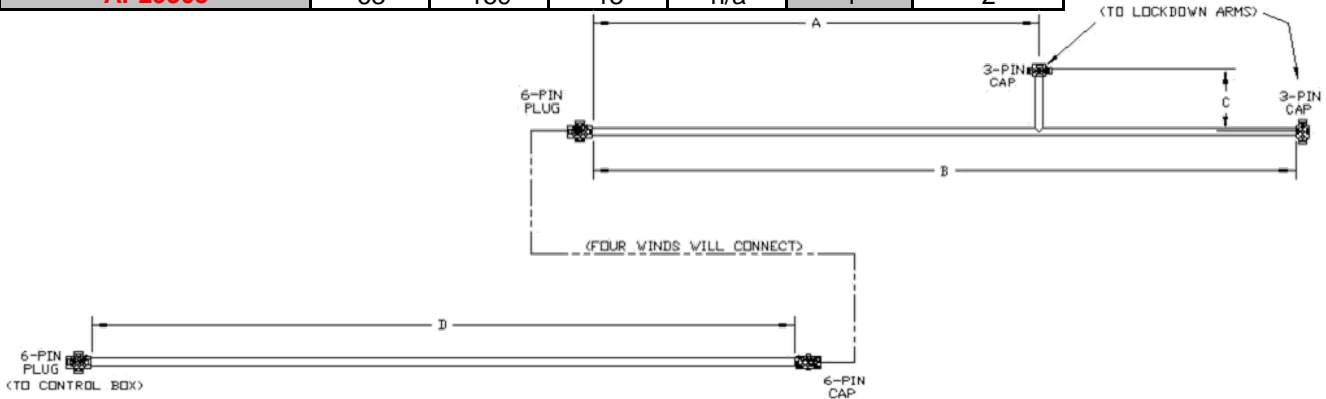

2005 and 2006 40E 40G

Harness connecting lockdown arm control module for Room #1 to pump =	160"	
Harness connecting lockdown arm control module for Room #2 to pump =	430"	
Harness connecting lockdown arm control module for Room #3 to pump =	no lock-arms	
Harness connecting lockdown arm control module for Room #4 to pump =	250"	
Harness connecting lockdown arm control module for Room #1 to panel =	432"	AP29292
Harness connecting lockdown arm control module for Room #2 & #4 to panel =	480"	AP29288
<u>Harness from Dewald bedslide to HWH pump:</u>	500"	

(used with room #3)

Other Parts

<u>Description:</u>	<u>Print #</u>	<u>Quan.</u>	<u>Vendor</u>	<u>Vendor #</u>
36" Slide Mechanism	n/a	2	HWH	AP25893
18" Slide Mechanism	n/a	2	HWH	AP26810
Hardware Kit	FM-2158	4	HWH	AP27968
Angle, Room Mount (short)	FM-1806	1	HWH	AP27499
Angle, Room Mount (long)	FM-1806	1	HWH	P26223
Cylinder, Bed Slide	n/a	1	HWH	AP27411
Sync Cylinder	n/a	1	HWH	AP29839
Nylon Strip (beveled)	n/a	3.5	HWH	P14291
Bed Slide Mechanism	FM-1871	1	Power Gear	
Angle, Room Mount (short)	FM-2158	1	HWH	P29809
Angle, Room Mount (long)	FM-2158	1	HWH	AP29804

Revisions:

- Released to HWH and production NS, 4-22-04
- Added HWH part number for leveling system & corrected bed slide mechanism part number NS, 5-14-04
- Added "Harness from Dewald bedslide to HWH pump" for room #2 NS, 6-10-04
- Added semi-auto leveling as the standard for Mandalay (two possible kits for every coach now)
- Changed hose length for room #1 to reference FM-3090 NS, 7-2-04
- Changed multiplex harness length from 8' to 12' for touch pad NS, 7-8-04
- Added the HWH hose kit part number NS, 7-13-04
- Added the harnesses that connect the lockdown control module to the panel NS, 7-26-04
- Changed dinette slide switch sensor harness (room #1) ECN #3140 NS 9-27-04
- Updated room #1 with 192" harness per HWH NS, 10-11-04
- Updated per ECN #3429, all dinette slide outs take same lock down arm harness NS, 4-22-05
- Modified hose length from sync cylinder to pump; see FM-3090-1 (ECN #3477) NS, 6-2-05
- Changed length of AP29288, was 672" now 480" (ECN #3619) NS, 8-24-05

40F Slide Components (auto-option)

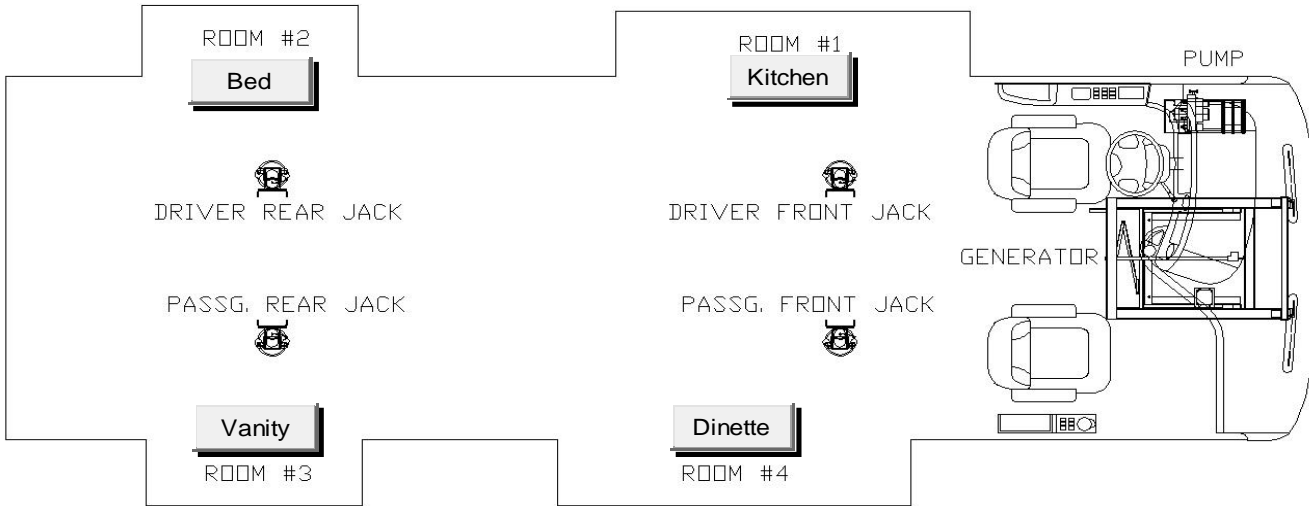

Leveling System = **AP34286**

Hose Kit = **AP33443**

Description:	Room #1	Room #2	Room #3	Room #4	Generator	Front Jacks	Rear Jacks	Total:
Length: (feet)	16	41	36	FM-3090	5	11	33	142

Notes: The hose kit will include the following: touch panel w/ 12' multiplex harness that connects to pump, 12K lb front and rear jacks with cross ties, power unit with valving for 4 room extensions and one generator extension, automatic leveling sensors, & a sync cylinder

HWH Electrical Harnesses

Switch Sensor Harness:

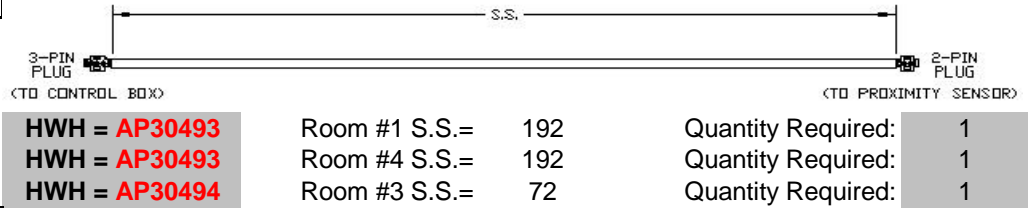

Lockdown Arms:

HWH Part #	Dimension (inches)				Quantity	Room #
	A	B	C	D		
AP34298	180	340	19	n/a	1	1
AP30495	n/a	n/a	n/a	126	2	3 & 4
AP34480	6	192	96	n/a	1	4
AP29305	63	159	13	n/a	1	3

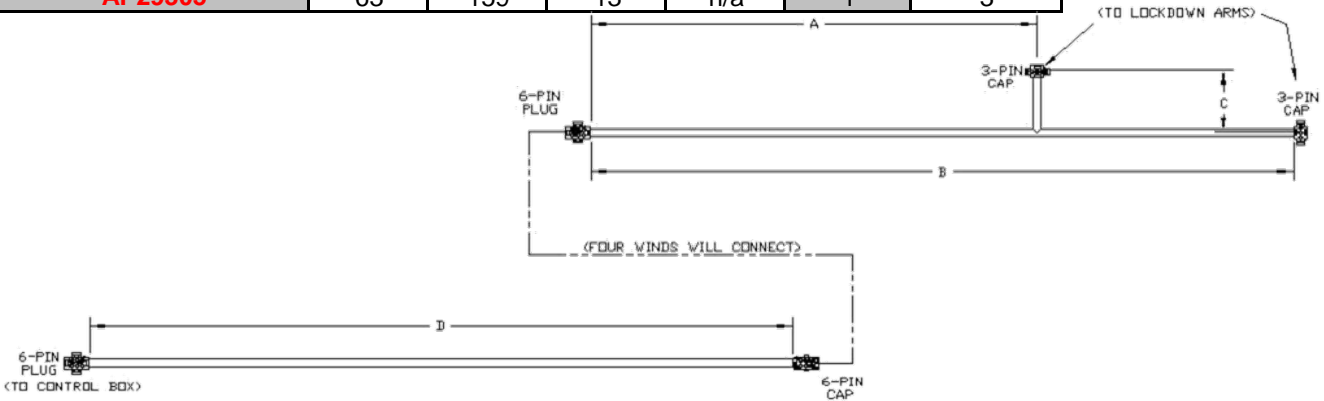

2005 and 2006 40F

Harness connecting lockdown arm control module for Room #1 to pump =	250"	
Harness connecting lockdown arm control module for Room #2 to pump =	no lock-arms	
Harness connecting lockdown arm control module for Room #3 to pump =	430"	
Harness connecting lockdown arm control module for Room #4 to pump =	250"	
Harness connecting lockdown arm control module for Room #1 to panel =	432"	AP29292
Harness connecting lockdown arm control module for Room #3 & #4 to panel =	480"	AP29288

Harness from Dewald bedside to HWH pump: 500"
 (used with room #2)

Other Parts

<u>Description:</u>	<u>Print #</u>	<u>Quan.</u>	<u>Vendor</u>	<u>Vendor #</u>
36" Slide Mechanism	n/a	2	HWH	AP25893
18" Slide Mechanism	n/a	2	HWH	AP26810
Hardware Kit	FM-2158	4	HWH	AP27968
Angle, Room Mount (short)	FM-1806	1	HWH	AP27499
Angle, Room Mount (long)	FM-1806	1	HWH	P26223
Cylinder, Bed Slide	n/a	1	HWH	AP27411
Sync Cylinder	n/a	1	HWH	AP29839
Nylon Strip (beveled)	n/a	3.5	HWH	P14291
Bed Slide Mechanism	FM-1871	1	Power Gear	
Angle, Room Mount (short)	FM-2158	1	HWH	P29809
Angle, Room Mount (long)	FM-2158	1	HWH	AP29804

- Revisions:**
1. Added on 8-3-04 NS
 2. Chagned lock down harness for room #4 (no units built yet) 9-21-04
 3. Changed dinette slide switch sensor harness (room #4) ECN #3140 NS 9-27-04
 4. Updated room #4 with 192" harness and added leveling system kit # per HWH NS,10-11-04
 5. Adjusted room #1 and #4 lockdown arm harnesses for better wire routing NS, 12-28-04 ecn #3304
 6. Updated per ECN #3429, all dinette slide outs take same lock down arm harness NS, 4-22-05
 7. Modified hose length from sync cylinder to pump; see FM-3090-1 (ECN #3477) NS, 6-2-05
 8. Changed length of AP29288, was 672" now 480" (ECN #3619) NS, 8-24-05

38B Slide Components (standard 325 series)

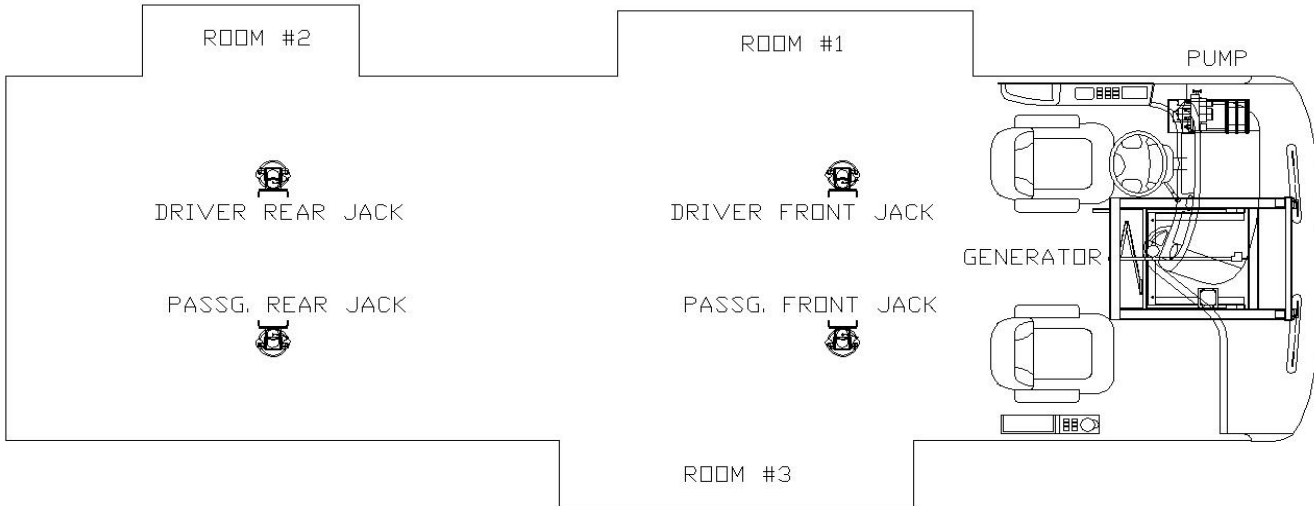

Leveling System = **AP33645**

Hose Kit = **AP33457**

Description:	Room #1	Room #2	Room #3	Room #4	Generator	Front Jacks	Rear Jacks	Total:
Length: (feet)	FM-3090	39	16	0	5	11	31	102

Notes: The hose kit will include the following: touch panel w/ 12' multiplex harness that connects to pump, 12K lb front and rear jacks with cross ties, power unit with valving for 3 room extensions and one generator extension, automatic leveling sensors, & a sync cylinder

HWH Electrical Harnesses

Switch Sensor Harness:

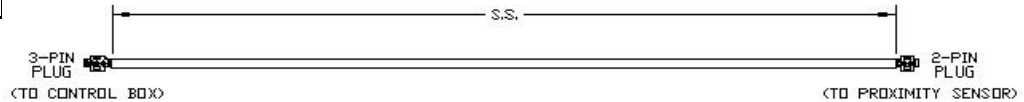

HWH = **AP28661**

Room #1 S.S. = 144"

Quantity Required: 2

Lockdown Arms:

HWH Part #	Dimension (inches)				Quantity	Room #
	A	B	C	D		
AP29304	100	264	10	n/a	1	1
AP30496	n/a	n/a	n/a	120	1	1
AP29469	180	340	19	n/a	1	3

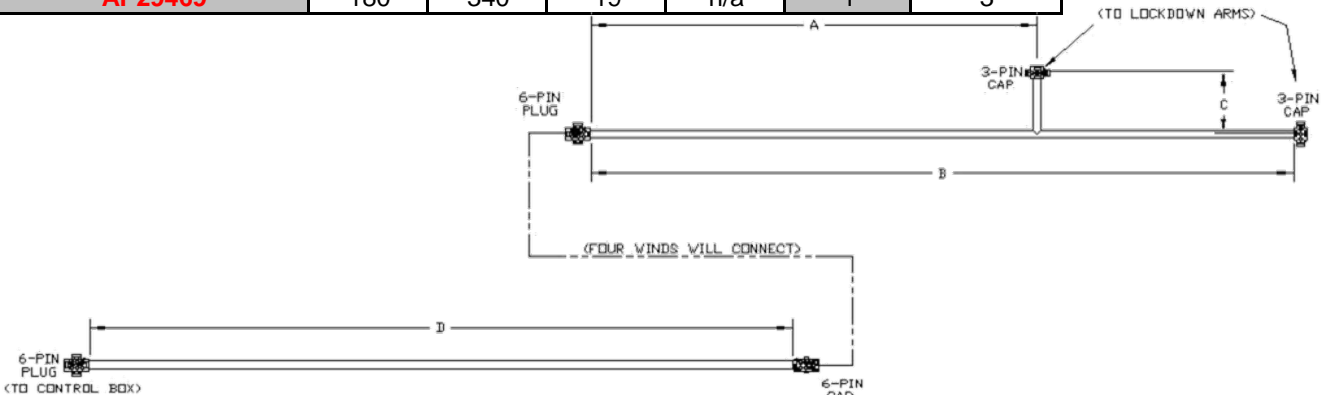

Harness connecting lockdown arm control module for Room #1 to pump =	^{CAP} 160"	
Harness connecting lockdown arm control module for Room #2 to pump =	no lock-arms	
Harness connecting lockdown arm control module for Room #3 to pump =	250"	
Harness connecting lockdown arm control module for Room #4 to pump =	n/a	
Harness connecting lockdown arm control module for Room #1 to panel =	432"	AP29292
Harness connecting lockdown arm control module for Room #3 to panel =	672"	AP29288

Harness from Dewald bedslide to HWH pump: 475"
 (used with room #2)

Other Parts

<u>Description:</u>	<u>Print #</u>	<u>Quan.</u>	<u>Vendor</u>	<u>Vendor #</u>
36" Slide Mechanism	n/a	2	HWH	AP25893
18" Slide Mechanism	n/a	1	HWH	AP26810
Hardware Kit	FM-1806	1	HWH	AP27968
Angle, Room Mount (short)	FM-1806	1	HWH	AP27499
Angle, Room Mount (long)	FM-1806	1	HWH	P26223
Cylinder, Bed Slide	n/a	1	HWH	AP27411
Sync Cylinder	n/a	1	HWH	AP29839
Nylon Strip (beveled)	n/a	3	HWH	P14291
Bed Slide Mechanism	FM-2014	1	Power Gear	59-754-0100

- Revisions:**
1. Released to HWH and production NS, 4-22-04
 2. Added HWH part number for leveling system NS, 5-14-04
 3. Added "Harness from Dewald bedslide to HWH pump" for room #2 NS, 6-10-04
 4. Added semi-auto leveling as the standard for Mandalay (two possible kits for every coach now)
 5. Changed hose length for room #1 to reference FM-3090 NS, 7-2-04
 6. Changed multiplex harness length from 8' to 12' for touch pad NS, 7-8-04
 7. Added the HWH hose kit part number NS, 7-13-04
 8. Added the harnesses that connect the lockdown control module to the panel NS, 7-26-04

40B Slide Components (standard 325 series)

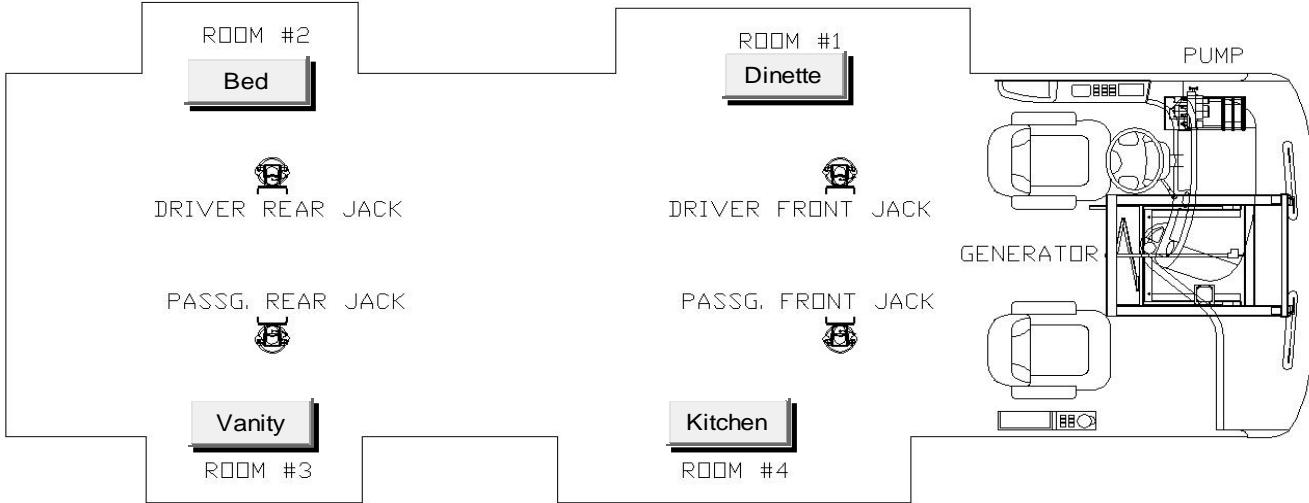

Leveling System = **AP33643**

Hose Kit = **AP33444**

Description:	Room #1	Room #2	Room #3	Room #4	Generator	Front Jacks	Rear Jacks	Total:
Length: (feet)	FM-3090	41	36	16	5	11	33	142

Notes: The hose kit will include the following: touch panel w/ 12' multiplex harness that connects to pump, 12K lb front and rear jacks with cross ties, power unit with valving for 4 room extensions and one generator extension, automatic leveling sensors, & a sync cylinder

HWH Electrical Harnesses

Switch Sensor Harness:

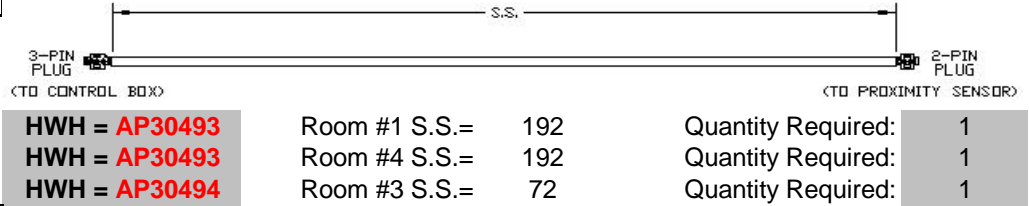

Lockdown Arms:

HWH Part #	Dimension (inches)				Quantity	Room #
	A	B	C	D		
AP34480	6	192	96	n/a	1	1
AP30495	n/a	n/a	n/a	126	2	1 & 3
AP29469	180	340	19	n/a	1	4
AP29305	63	159	13	n/a	1	3

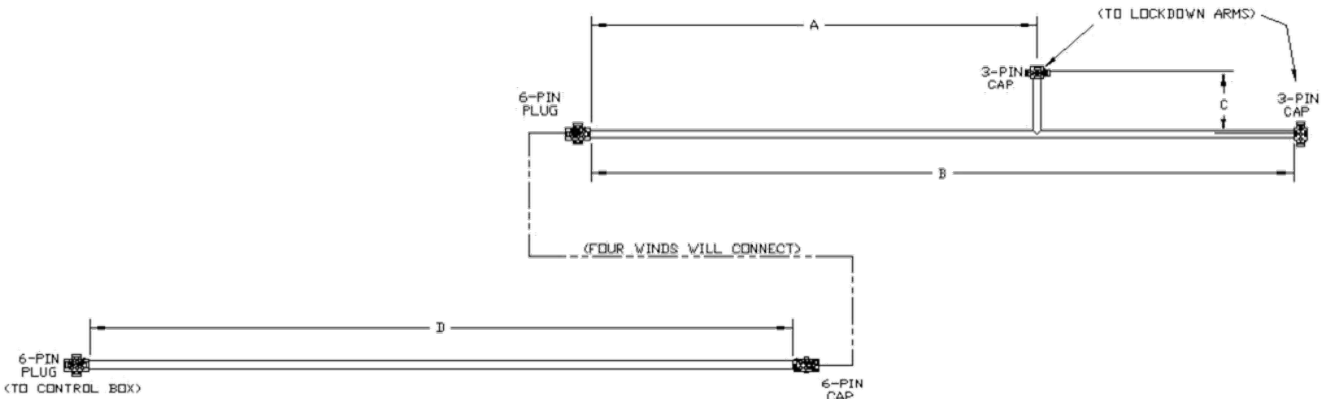

2005 and 2006 40B

Harness connecting lockdown arm control module for Room #1 to pump =	160"	
Harness connecting lockdown arm control module for Room #2 to pump =	no lock-arms	
Harness connecting lockdown arm control module for Room #3 to pump =	430"	
Harness connecting lockdown arm control module for Room #4 to pump =	250"	
Harness connecting lockdown arm control module for Room #1 to panel =	432"	AP29292
Harness connecting lockdown arm control module for Room #3 & #4 to panel =	480"	AP29288
<u>Harness from Dewald bedslide to HWH pump:</u>	500"	

(used with room #2)

Other Parts

<u>Description:</u>	<u>Print #</u>	<u>Quan.</u>	<u>Vendor</u>	<u>Vendor #</u>
36" Slide Mechanism	n/a	2	HWH	AP25893
18" Slide Mechanism	n/a	2	HWH	AP26810
Hardware Kit	FM-2158	4	HWH	AP27968
Angle, Room Mount (short)	FM-1806	1	HWH	AP27499
Angle, Room Mount (long)	FM-1806	1	HWH	P26223
Cylinder, Bed Slide	n/a	1	HWH	AP27411
Sync Cylinder	n/a	1	HWH	AP29839
Nylon Strip (beveled)	n/a	3.5	HWH	P14291
Bed Slide Mechanism	FM-2014	1	Power Gear	
Angle, Room Mount (short)	FM-2158	1	HWH	P29809
Angle, Room Mount (long)	FM-2158	1	HWH	AP29804

Revisions:

- Released to HWH and production NS, 4-22-04
- Added HWH part number for leveling system NS, 5-14-04
- Added "Harness from Dewald bedslide to HWH pump" for room #2 NS, 6-10-04
- Added semi-auto leveling as the standard for Mandalay (two possible kits for every coach now)
- Changed hose length for room #1 to reference FM-3090 NS, 7-2-04
- Changed multiplex harness length from 8' to 12' for touch pad NS, 7-8-04
- Added the HWH hose kit part number NS, 7-13-04
- Added the harnesses that connect the lockdown control module to the panel NS, 7-26-04
- Changed dinette slide switch sensor harness (room #1) ECN #3140 NS 9-27-04
- Updated room #1 with 192" harness per HWH NS, 10-11-04
- Updated per ECN #3429, all dinette slide outs take same lock down arm harness NS, 4-22-05
- Modified hose length from sync cylinder to pump; see FM-3090-1 (ECN #3477) NS, 6-2-05
- Changed length of AP29288, was 672" now 480" (ECN #3619) NS, 8-24-05

40D Slide Components (standard 325 series)

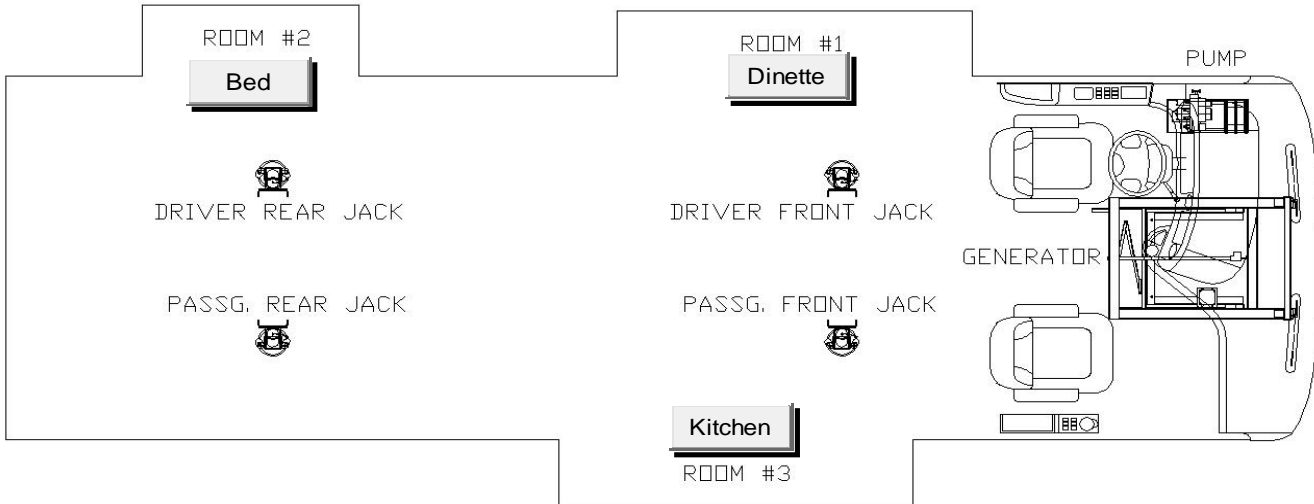

Leveling System = AP33647

Hose Kit = AP33458

Description:	Room #1	Room #2	Room #3	Room #4	Generator	Front Jacks	Rear Jacks	Total:
Length: (feet)	FM-3090	37	16	0	5	11	33	102

Notes: The hose kit will include the following: touch panel w/ 12' multiplex harness that connects to pump, 12K lb front and rear jacks with cross ties, power unit with valving for 3 room extensions and one generator extension, automatic leveling sensors, & a sync cylinder

HWH Electrical Harnesses

Switch Sensor Harness:

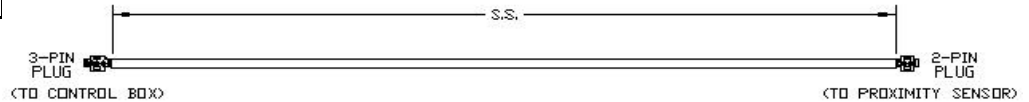

HWH = AP30493	Room #1 S.S. =	192	Quantity Required:	2
HWH = AP28661	Room #3 S.S. =	144	Quantity Required:	2

Lockdown Arms:

HWH Part #	Dimension (inches)				Quantity	Room #
	A	B	C	D		
AP34480	6	192	96	n/a	1	1
AP30495	n/a	n/a	n/a	126	1	1
AP29469	180	340	19	n/a	1	3

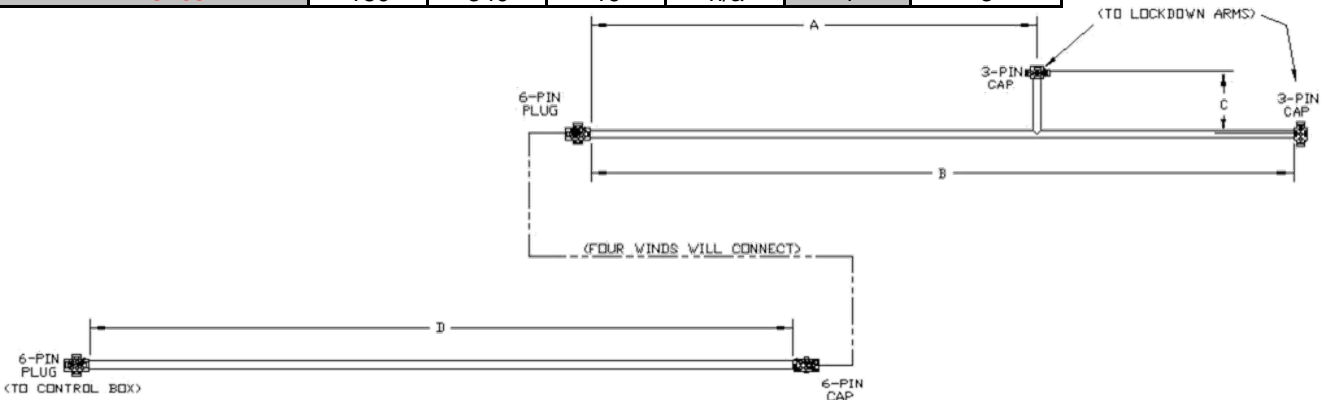

2005 and 2006 40D

Harness connecting lockdown arm control module for Room #1 to pump =	160"	
Harness connecting lockdown arm control module for Room #2 to pump =	no lock-arms	
Harness connecting lockdown arm control module for Room #3 to pump =	250"	
Harness connecting lockdown arm control module for Room #4 to pump =	n/a	
Harness connecting lockdown arm control module for Room #1 to panel =	432"	AP29292
Harness connecting lockdown arm control module for Room #3 to panel =	480"	AP29288

Harness from Dewald bedslide to HWH pump: 450"
 (used with room #2)

Other Parts

<u>Description:</u>	<u>Print #</u>	<u>Quan.</u>	<u>Vendor</u>	<u>Vendor #</u>
36" Slide Mechanism	n/a	2	HWH	AP25893
18" Slide Mechanism	n/a	1	HWH	AP26810
Hardware Kit	FM-2158	4	HWH	AP27968
Angle, Room Mount (long)	FM-2158	1	HWH	AP29804
Angle, Room Mount (long)	FM-1806	1	HWH	P26223
Cylinder, Bed Slide	n/a	1	HWH	AP27411
Sync Cylinder	n/a	1	HWH	AP29839
Nylon Strip (beveled)	n/a	2	HWH	P14291
Bed Slide Mechanism	FM-1871	1	Power Gear	
Angle, Room Mount (short)	FM-2158	1	HWH	P29809

- Revisions:**
- Released to HWH and production NS, 4-22-04
 - Added HWH part number for leveling system & corrected bed slide mechanism part number NS, 5-14-04
 - Added "Harness from Dewald bedslide to HWH pump" for room #2 NS, 6-10-04
 - Added semi-auto leveling as the standard for Mandalay (two possible kits for every coach now)
 - Corrected leveling system AP number NS, 6-15-04
 - Changed hose length for room #1 to reference FM-3090 NS, 7-2-04
 - Changed multiplex harness length from 8' to 12' for touch pad NS, 7-8-04
 - Added the HWH hose kit part number NS, 7-13-04
 - Added the harnesses that connect the lockdown control module to the panel NS, 7-26-04
 - Changed dinette slide switch sensor harness (room #1) ECN #3140 NS 9-27-04
 - Updated room #1 with 192" harness per HWH NS, 10-11-04
 - Updated per ECN #3429, all dinette slide outs take same lock down arm harness NS, 4-22-05
 - Modified hose length from sync cylinder to pump; see FM-3090-1 (ECN #3477) NS, 6-2-05
 - Changed length of AP29288, was 672" now 480" (ECN #3619) NS, 8-24-05

40E & 40G Slide Components (standard 325 series)

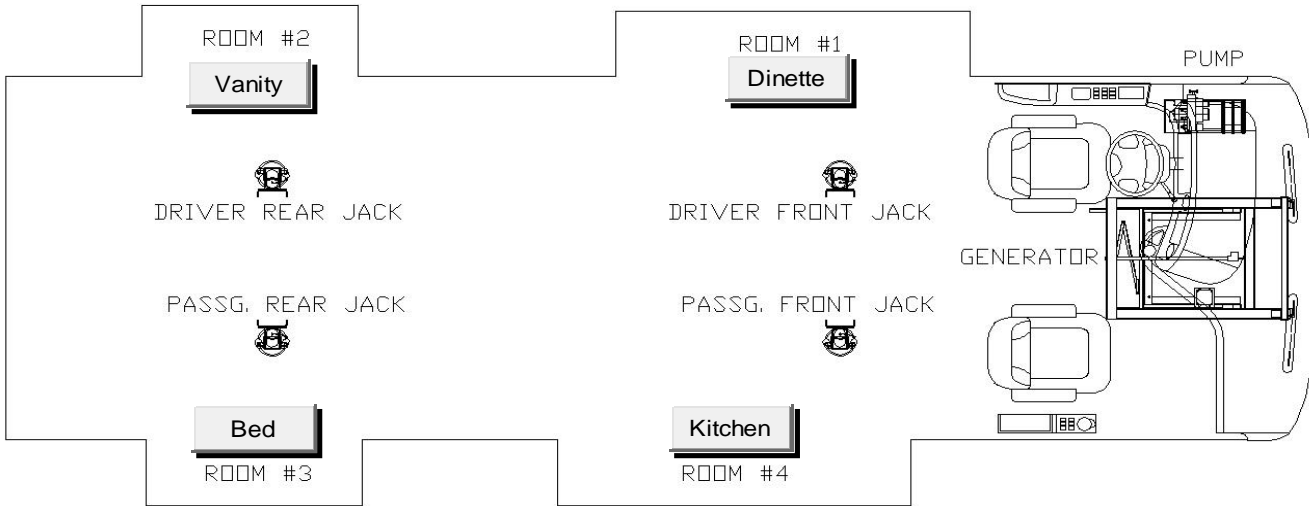

Leveling System = AP33641

Hose Kit = AP33443

Description:	Room #1	Room #2	Room #3	Room #4	Generator	Front Jacks	Rear Jacks	Total:
Length: (feet)	FM-3090	36	41	16	5	11	33	142

Notes: The hose kit will include the following: touch panel w/ 12' multiplex harness that connects to pump, 12K lb front and rear jacks with cross ties, power unit with valving for 4 room extensions and one generator extension, automatic leveling sensors, & a sync cylinder

HWH Electrical Harnesses

Switch Sensor Harness:

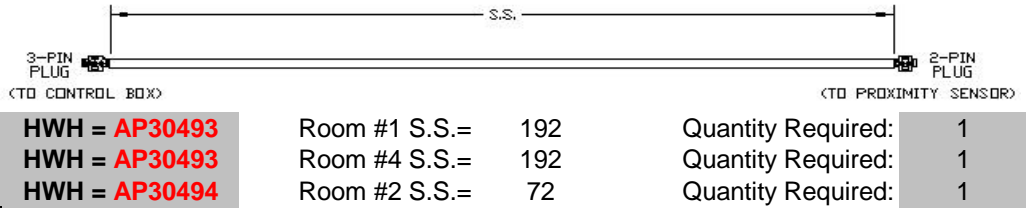

Lockdown Arms:

HWH Part #	Dimension (inches)				Quantity	Room #
	A	B	C	D		
AP34480	6	192	96	n/a	1	1
AP30495	n/a	n/a	n/a	126	2	1 & 2
AP29469	180	340	19	n/a	1	4
AP29305	63	159	13	n/a	1	2

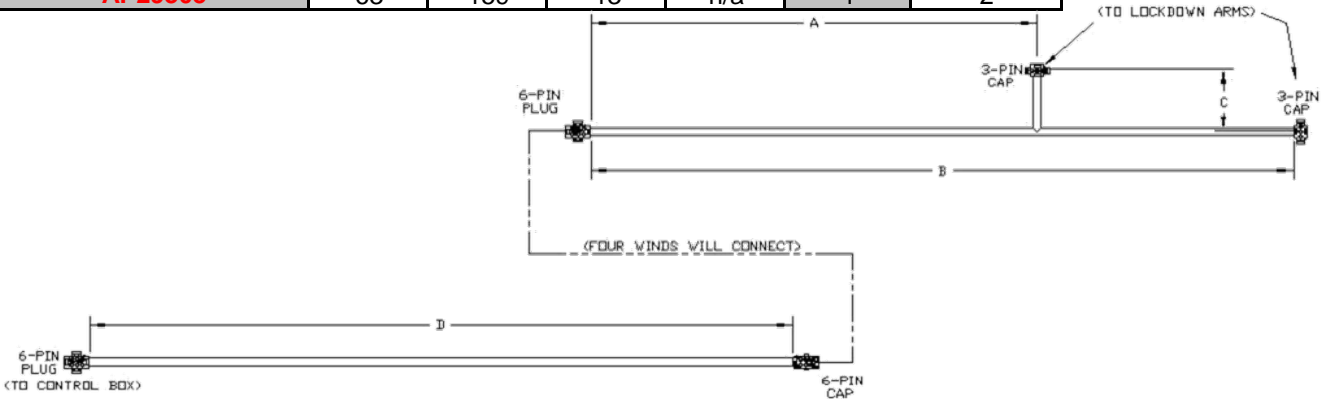

2005 and 2006 40E 40G

Harness connecting lockdown arm control module for Room #1 to pump =	160"	
Harness connecting lockdown arm control module for Room #2 to pump =	430"	
Harness connecting lockdown arm control module for Room #3 to pump =	no lock-arms	
Harness connecting lockdown arm control module for Room #4 to pump =	250"	
Harness connecting lockdown arm control module for Room #1 to panel =	432"	AP29292
Harness connecting lockdown arm control module for Room #2 & #4 to panel =	480"	AP29288
<u>Harness from Dewald bedslide to HWH pump:</u>	500"	

(used with room #3)

Other Parts

<u>Description:</u>	<u>Print #</u>	<u>Quan.</u>	<u>Vendor</u>	<u>Vendor #</u>
36" Slide Mechanism	n/a	2	HWH	AP25893
18" Slide Mechanism	n/a	2	HWH	AP26810
Hardware Kit	FM-2158	4	HWH	AP27968
Angle, Room Mount (short)	FM-1806	1	HWH	AP27499
Angle, Room Mount (long)	FM-1806	1	HWH	P26223
Cylinder, Bed Slide	n/a	1	HWH	AP27411
Sync Cylinder	n/a	1	HWH	AP29839
Nylon Strip (beveled)	n/a	3.5	HWH	P14291
Bed Slide Mechanism	FM-1871	1	Power Gear	
Angle, Room Mount (short)	FM-2158	1	HWH	P29809
Angle, Room Mount (long)	FM-2158	1	HWH	AP29804

Revisions:

- Released to HWH and production NS, 4-22-04
- Added HWH part number for leveling system & corrected bed slide mechanism part number NS, 5-14-04
- Added "Harness from Dewald bedslide to HWH pump" for room #2 NS, 6-10-04
- Added semi-auto leveling as the standard for Mandalay (two possible kits for every coach now)
- Changed hose length for room #1 to reference FM-3090 NS, 7-2-04
- Changed multiplex harness length from 8' to 12' for touch pad NS, 7-8-04
- Added the HWH hose kit part number NS, 7-13-04
- Added the harnesses that connect the lockdown control module to the panel NS, 7-26-04
- Changed dinette slide switch sensor harness (room #1) ECN #3140 NS 9-27-04
- Updated room #1 with 192" harness per HWH NS, 10-11-04
- Updated per ECN #3429, all dinette slide outs take same lock down arm harness NS, 4-22-05
- Modified hose length from sync cylinder to pump; see FM-3090-1 (ECN #3477) NS, 6-2-05
- Changed length of AP29288, was 672" now 480" (ECN #3619) NS, 8-24-05

40F Slide Components (standard 325 series)

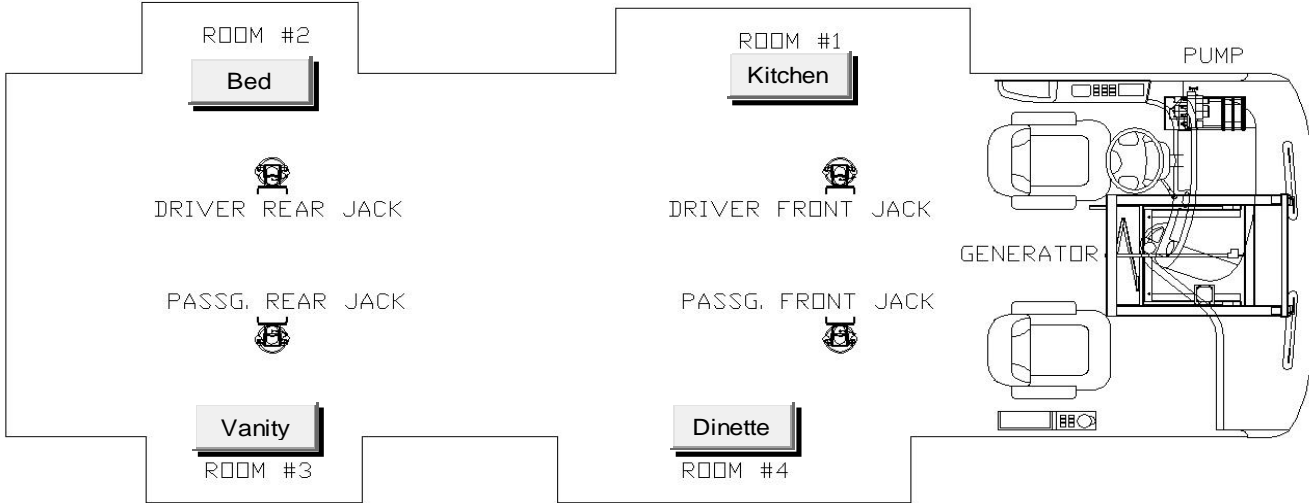

Leveling System = **AP34284**

Hose Kit = **AP33443**

Description:	Room #1	Room #2	Room #3	Room #4	Generator	Front Jacks	Rear Jacks	Total:
Length: (feet)	16	41	36	FM-3090	5	11	33	142

Notes: The hose kit will include the following: touch panel w/ 12' multiplex harness that connects to pump, 12K lb front and rear jacks with cross ties, power unit with valving for 4 room extensions and one generator extension, automatic leveling sensors, & a sync cylinder

HWH Electrical Harnesses

Switch Sensor Harness:

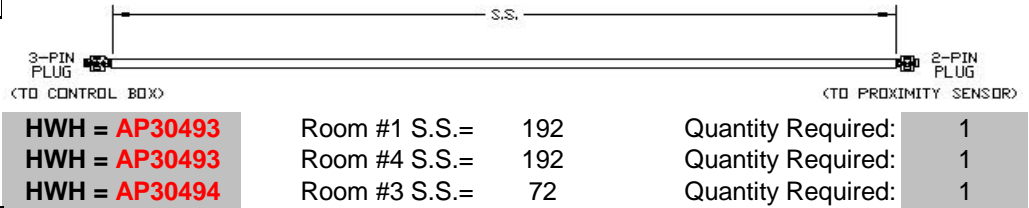

Lockdown Arms:

HWH Part #	Dimension (inches)				Quantity	Room #
	A	B	C	D		
AP34289	180	340	19	n/a	1	1
AP30495	n/a	n/a	n/a	126	2	3 & 4
AP34480	6	192	96	n/a	1	4
AP29305	63	159	13	n/a	1	3

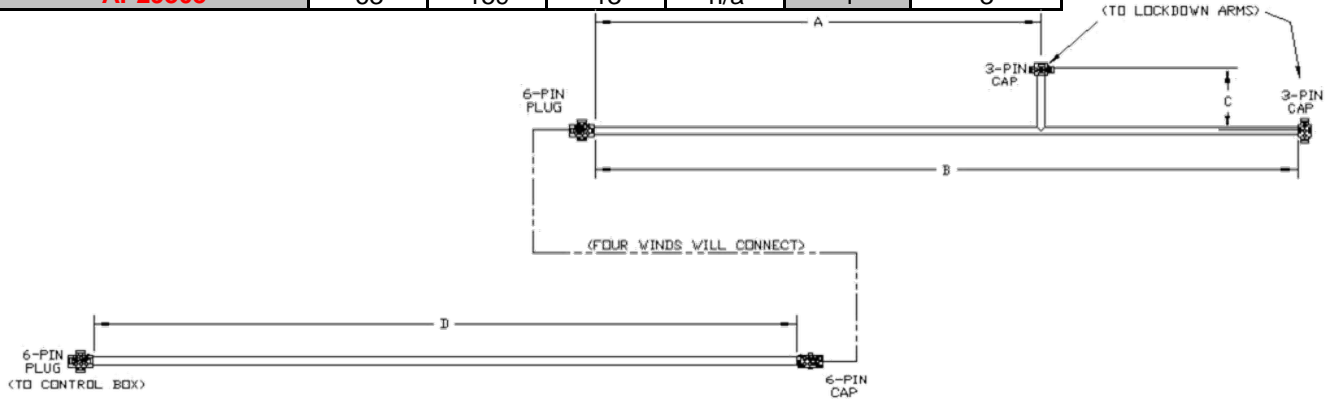

2005 and 2006 40F

Harness connecting lockdown arm control module for Room #1 to pump = 250"
 Harness connecting lockdown arm control module for Room #2 to pump = no lock-arms
 Harness connecting lockdown arm control module for Room #3 to pump = 430"
 Harness connecting lockdown arm control module for Room #4 to pump = 250"
 Harness connecting lockdown arm control module for Room #1 to panel = 432" **AP29292**
 Harness connecting lockdown arm control module for Room #3 & #4 to panel = 480" **AP29288**

Harness from Dewald bedside to HWH pump: 500"
 (used with room #2)

Other Parts

<u>Description:</u>	<u>Print #</u>	<u>Quan.</u>	<u>Vendor</u>	<u>Vendor #</u>
36" Slide Mechanism	n/a	2	HWH	AP25893
18" Slide Mechanism	n/a	2	HWH	AP26810
Hardware Kit	FM-2158	4	HWH	AP27968
Angle, Room Mount (short)	FM-1806	1	HWH	AP27499
Angle, Room Mount (long)	FM-1806	1	HWH	P26223
Cylinder, Bed Slide	n/a	1	HWH	AP27411
Sync Cylinder	n/a	1	HWH	AP29839
Nylon Strip (beveled)	n/a	3.5	HWH	P14291
Bed Slide Mechanism	FM-1871	1	Power Gear	
Angle, Room Mount (short)	FM-2158	1	HWH	P29809
Angle, Room Mount (long)	FM-2158	1	HWH	AP29804

- Revisions:**
1. Added on 8-3-04 NS
 2. Chagned lock down harness for room #4 (no units built yet) 9-21-04
 3. Changed dinette slide switch sensor harness (room #4) ECN #3140 NS 9-27-04
 4. Updated room #4 with 192" harness and added leveling system kit # per HWH NS,10-11-04
 5. Adjusted room #1 and #4 lockdown arm harnesses for better wire routing NS, 12-28-04 ecn #3304
 6. Updated per ECN #3429, all dinette slide outs take same lock down arm harness NS, 4-22-05
 7. Modified hose length from sync cylinder to pump; see FM-3090-1 (ECN #3477) NS, 6-2-05
 8. Changed length of AP29288, was 672" now 480" (ECN #3619) NS, 8-24-05

**30F HURRICANE (19.5) TIRES
EQUALIZER JACKS (FULLY AUTOMATIC)
STANDARD ON THIS UNIT**

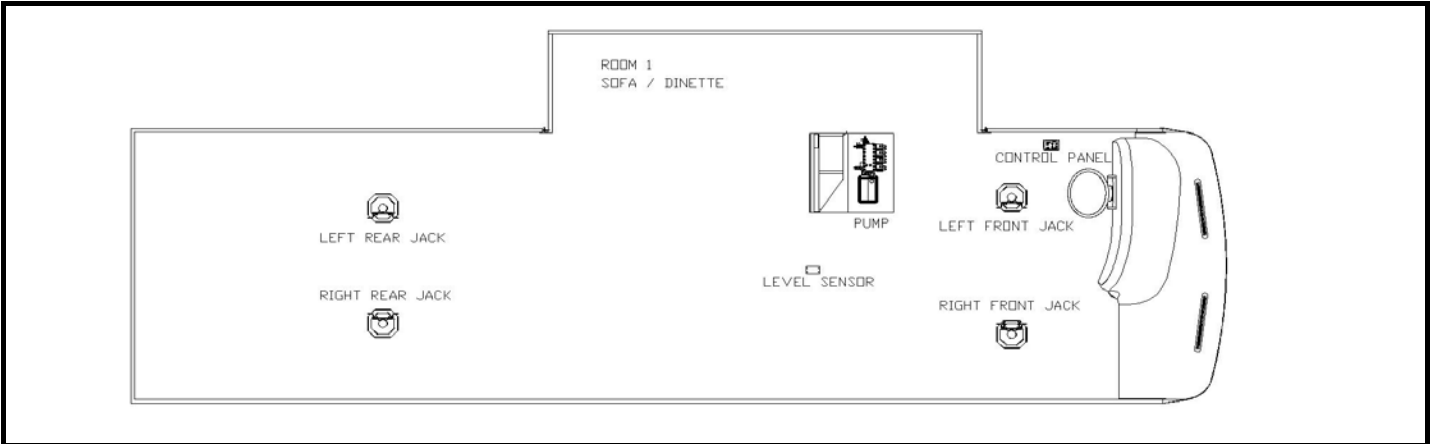

Notes:

- 1) Jacks mount in two different locations on bracket depending on tire size of chassis.
 - a) 19.5 Tires: Top hole in jack to top hole in bracket. Use 4 bolts in welded area of bracket.
 - b) 22.5 Tires: Top hole in jack to second hole in bracket. Use 6 bolts, 4 in welded area of bracket & 2 below welded area.

Item, Length	Description / Location	Qty	Color	Vendor PN	
Kit	(Items listed below)	1		8267	Measuring from inside of firewall, this is the end location of the hydraulic hoses where they attach to the slide mechanism.
Pump	5-Function, 1 Room, Jacks	1		7242	
Jack	12,000 lbs, 16" Stroke	4		7214	
Control Panel	Located to the left of the drivers seat	1		2057	
Level Sensor	Attached to bottom of structure	1		7196	
Flow Divider	Mounted inside pump compartment	N/A		N/A	
Hose, 140	Pump to Jack, Left Front	2	Brown	7294	
Hose, 240	Pump to Jack, Left Rear	2	Orange	7295	
Hose, 180	Pump to Jack, Right Front	2	White	7296	
Hose, 280	Pump to Jack, Right Rear	2	Yellow	7297	
Hose, N/A	Pump to Flow Divider	N/A	Green	N/A	N/A
Hose, N/A	Flow divider to front slide, Room 1	N/A	Green	N/A	N/A
Hose, N/A	Flow divider to rear slide, Room 1	N/A	Green	N/A	N/A
Hose, 48	Pump to Room 1	2	Green	7306	127 / Drivers Side
Hose, N/A	Pump to Room 2	N/A	Purple	N/A	N/A
Hose, N/A	Pump to Room 3	N/A	Gray	N/A	N/A
Hose, N/A	Pump to Room 4	N/A	Red	N/A	N/A
Hose, N/A	Pump to Generator Slide	N/A		N/A	N/A
Travel Clamp	Two per Slide	N/A		HWH	N/A

Options					

Revisions					
1	Change hose length fro room 1 from 32 to 48 (10/19/05 MJK)				

**30Q HURRICANE (19.5) TIRES
EQUALIZER JACKS (FULLY AUTOMATIC)
OPTIONAL ON THIS UNIT**



Notes:

1) Jacks mount in two different locations on bracket depending on tire size of chassis.

a) 19.5 Tires: Top hole in jack to top hole in bracket. Use 4 bolts in welded area of bracket.

b) 22.5 Tires: Top hole in jack to second hole in bracket. Use 6 bolts, 4 in welded area of bracket & 2 below welded area.

Item, Length	Description / Location	Qty	Color	Vendor PN		
Kit	(Items listed below)	1		8252	Measuring from inside of firewall, this is the end location of the hydraulic hoses where they attach to the slide mechanism.	
Pump	4-Function, Jacks	1		7239		
Jack	12,000 lbs, 16" Stroke	4		7214		
Control Panel	Located to the left of the drivers seat	1		2057		
Level Sensor	Attached to bottom of structure	1		7196		
Flow Divider	Mounted inside pump compartment	N/A		N/A		
Hose, 140	Pump to Jack, Left Front	2	Brown	7294		
Hose, 240	Pump to Jack, Left Rear	2	Orange	7295		
Hose, 180	Pump to Jack, Right Front	2	White	7296		
Hose, 280	Pump to Jack, Right Rear	2	Yellow	7297		
Hose, N/A	Pump to Flow Divider	N/A	Green	N/A		N/A
Hose, N/A	Flow divider to front slide, Room 1	N/A	Green	N/A		N/A
Hose, N/A	Flow divider to rear slide, Room 1	N/A	Green	N/A		N/A
Hose, N/A	Pump to Room 1	N/A	Green	N/A		N/A
Hose, N/A	Pump to Room 2	N/A	Purple	N/A		N/A
Hose, N/A	Pump to Room 3	N/A	Gray	N/A		N/A
Hose, N/A	Pump to Room 4	N/A	Red	N/A	N/A	
Hose, N/A	Pump to Generator Slide	N/A		N/A	N/A	
Travel Clamp	Two per Slide	N/A		HWH	N/A	

Options

Revisions

**31D HURRICANE (19.5) TIRES
EQUALIZER JACKS (FULLY AUTOMATIC)
OPTIONAL ON THIS UNIT**

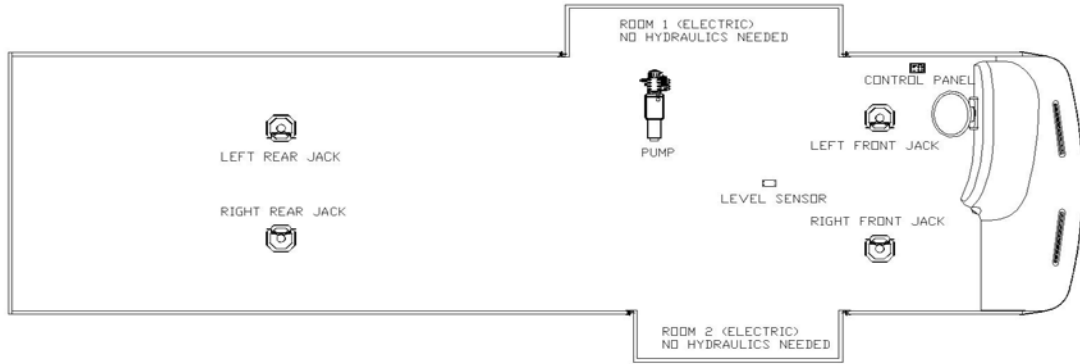

Notes:

1) Jacks mount in two different locations on bracket depending on tire size of chassis.

a) 19.5 Tires: Top hole in jack to top hole in bracket. Use 4 bolts in welded area of bracket.

b) 22.5 Tires: Top hole in jack to second hole in bracket. Use 6 bolts, 4 in welded area of bracket & 2 below welded area.

Item, Length	Description / Location	Qty	Color	Vendor PN		
Kit	(Items listed below)	1		8252	Measuring from inside of firewall, this is the end location of the hydraulic hoses where they attach to the slide mechanism.	
Pump	4-Function, Jacks	1		7239		
Jack	12,000 lbs, 16" Stroke	4		7214		
Control Panel	Located to the left of the drivers seat	1		2057		
Level Sensor	Attached to bottom of structure	1		7196		
Flow Divider	Mounted inside pump compartment	N/A		N/A		
Hose, 140	Pump to Jack, Left Front	2	Brown	7294		
Hose, 240	Pump to Jack, Left Rear	2	Orange	7295		
Hose, 180	Pump to Jack, Right Front	2	White	7296		
Hose, 280	Pump to Jack, Right Rear	2	Yellow	7297		
Hose, N/A	Pump to Flow Divider	N/A	Green	N/A		N/A
Hose, N/A	Flow divider to front slide, Room 1	N/A	Green	N/A		N/A
Hose, N/A	Flow divider to rear slide, Room 1	N/A	Green	N/A		N/A
Hose, N/A	Pump to Room 1	N/A	Green	N/A		N/A
Hose, N/A	Pump to Room 2	N/A	Purple	N/A		N/A
Hose, N/A	Pump to Room 3	N/A	Gray	N/A		N/A
Hose, N/A	Pump to Room 4	N/A	Red	N/A	N/A	
Hose, N/A	Pump to Generator Slide	N/A		N/A	N/A	
Travel Clamp	Two per Slide	N/A		HWH	N/A	

Options

Revisions

**31H HURRICANE (19.5) TIRES
EQUALIZER JACKS (FULLY AUTOMATIC)
OPTIONAL ON THIS UNIT**

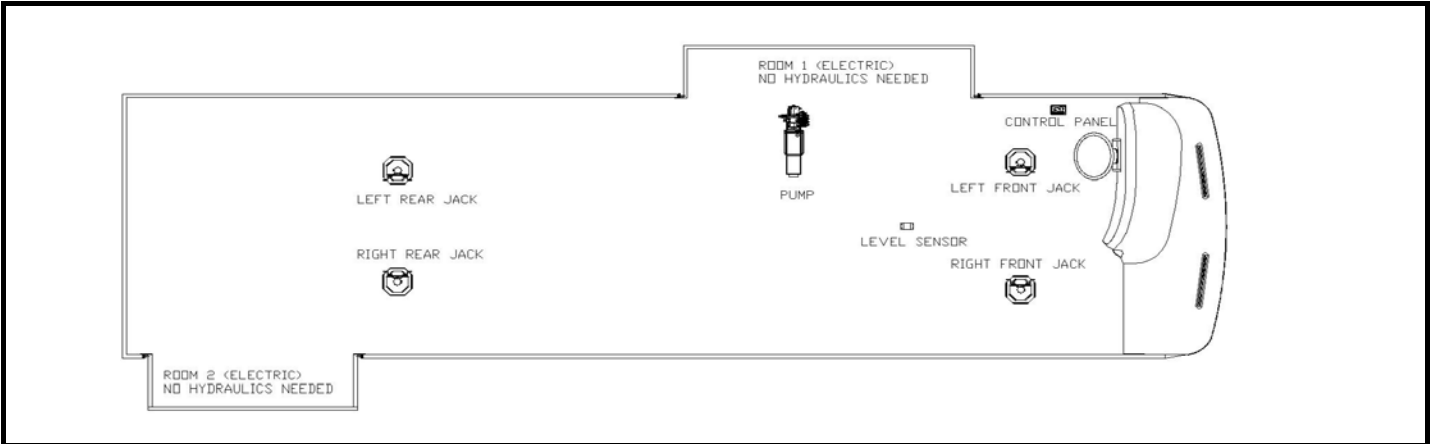

Notes:

- 1) Jacks mount in two different locations on bracket depending on tire size of chassis.
 - a) 19.5 Tires: Top hole in jack to top hole in bracket. Use 4 bolts in welded area of bracket.
 - b) 22.5 Tires: Top hole in jack to second hole in bracket. Use 6 bolts, 4 in welded area of bracket & 2 below welded area.

Item, Length	Description / Location	Qty	Color	Vendor PN		
Kit	(Items listed below)	1		8252	Measuring from inside of firewall, this is the end location of the hydraulic hoses where they attach to the slide mechanism.	
Pump	4-Function, Jacks	1		7239		
Jack	12,000 lbs, 16" Stroke	4		7214		
Control Panel	Located to the left of the drivers seat	1		2057		
Level Sensor	Attached to bottom of structure	1		7196		
Flow Divider	Mounted inside pump compartment	N/A		N/A		
Hose, 140	Pump to Jack, Left Front	2	Brown	7294		
Hose, 240	Pump to Jack, Left Rear	2	Orange	7295		
Hose, 180	Pump to Jack, Right Front	2	White	7296		
Hose, 280	Pump to Jack, Right Rear	2	Yellow	7297		
Hose, N/A	Pump to Flow Divider	N/A	Green	N/A		N/A
Hose, N/A	Flow divider to front slide, Room 1	N/A	Green	N/A		N/A
Hose, N/A	Flow divider to rear slide, Room 1	N/A	Green	N/A		N/A
Hose, N/A	Pump to Room 1	N/A	Green	N/A		N/A
Hose, N/A	Pump to Room 2	N/A	Purple	N/A		N/A
Hose, N/A	Pump to Room 3	N/A	Gray	N/A		N/A
Hose, N/A	Pump to Room 4	N/A	Red	N/A		N/A
Hose, N/A	Pump to Generator Slide	N/A		N/A	N/A	
Travel Clamp	Two per Slide	N/A		HWH	N/A	

Options

Revisions

**32R HURRICANE (19.5) TIRES
EQUALIZER JACKS (FULLY AUTOMATIC)
STANDARD ON THIS UNIT**

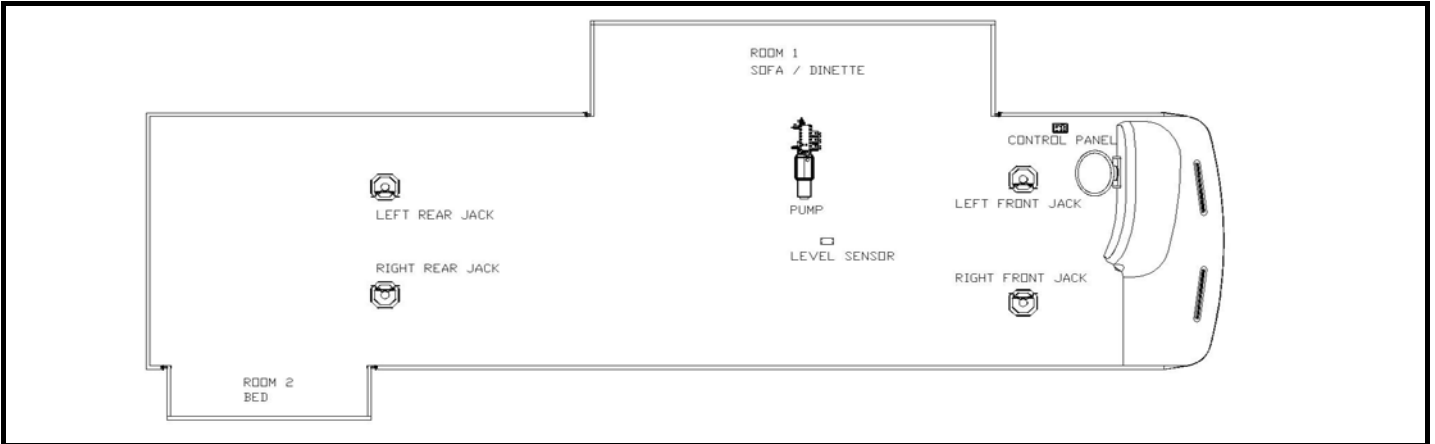

Notes:

- 1) Jacks mount in two different locations on bracket depending on tire size of chassis.
 - a) 19.5 Tires: Top hole in jack to top hole in bracket. Use 4 bolts in welded area of bracket.
 - b) 22.5 Tires: Top hole in jack to second hole in bracket. Use 6 bolts, 4 in welded area of bracket & 2 below welded area.

Item, Length	Description / Location	Qty	Color	Vendor PN		
Kit	(Items listed below)	1		8254	Measuring from inside of firewall, this is the end location of the hydraulic hoses where they attach to the slide mechanism.	
Pump	6-Function, 2 Rooms, Jacks	1		7243		
Jack	12,000 lbs, 16" Stroke	4		7214		
Control Panel	Located to the left of the drivers seat	1		2057		
Level Sensor	Attached to bottom of structure	1		7196		
Flow Divider	Mounted inside pump compartment	N/A		N/A		
Hose, 140	Pump to Jack, Left Front	2	Brown	7294		
Hose, 240	Pump to Jack, Left Rear	2	Orange	7295		
Hose, 180	Pump to Jack, Right Front	2	White	7296		
Hose, 280	Pump to Jack, Right Rear	2	Yellow	7297		
Hose, N/A	Pump to Flow Divider	N/A	Green	N/A		N/A
Hose, N/A	Flow divider to front slide, Room 1	N/A	Green	N/A		N/A
Hose, N/A	Flow divider to rear slide, Room 1	N/A	Green	N/A		N/A
Hose, 32	Pump to Room 1	2	Green	7298		127 / Drivers Side
Hose, 364	Pump to Room 2	2	Purple	7300		305 / Passenger Side
Hose, N/A	Pump to Room 3	N/A	Gray	N/A		N/A
Hose, N/A	Pump to Room 4	N/A	Red	N/A		N/A
Hose, N/A	Pump to Generator Slide	N/A		N/A		N/A
Travel Clamp	Two per Slide	N/A		HWH	N/A	

Options

Revisions

**33H HURRICANE (19.5) TIRES
EQUALIZER JACKS (FULLY AUTOMATIC)
STANDARD ON THIS UNIT**

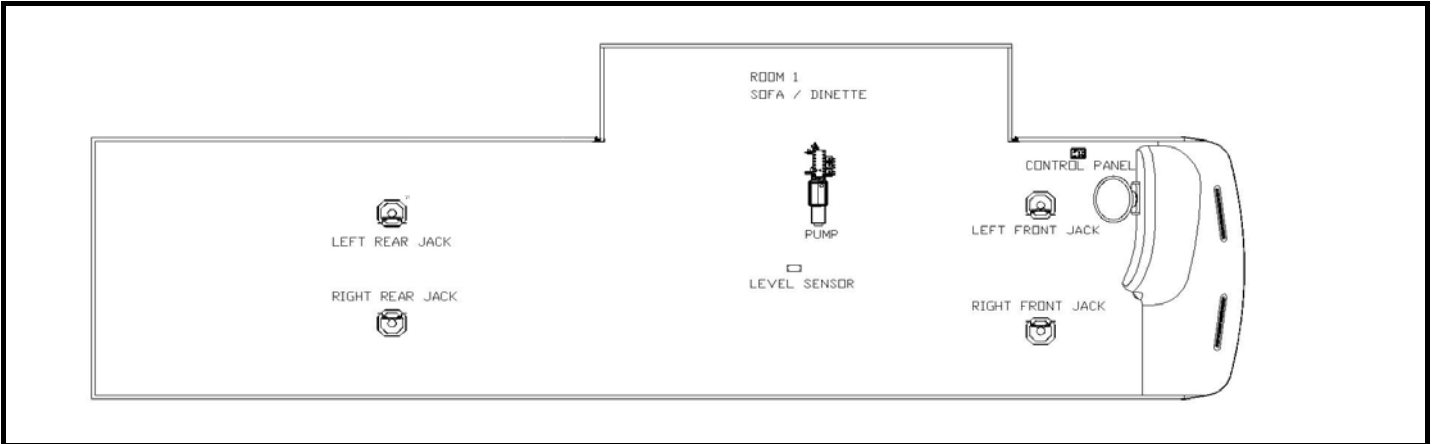

Notes:

- 1) Jacks mount in two different locations on bracket depending on tire size of chassis.
 - a) 19.5 Tires: Top hole in jack to top hole in bracket. Use 4 bolts in welded area of bracket.
 - b) 22.5 Tires: Top hole in jack to second hole in bracket. Use 6 bolts, 4 in welded area of bracket & 2 below welded area.

Item, Length	Description / Location	Qty	Color	Vendor PN	
Kit	(Items listed below)	1		8270	Measuring from inside of firewall, this is the end location of the hydraulic hoses where they attach to the slide mechanism.
Pump	5-Function, 1 Room, Jacks	1		7242	
Jack	12,000 lbs, 16" Stroke	4		7214	
Control Panel	Located to the left of the drivers seat	1		2057	
Level Sensor	Attached to bottom of structure	1		7196	
Flow Divider	Mounted inside pump compartment	N/A		N/A	
Hose, 140	Pump to Jack, Left Front	2	Brown	7294	
Hose, 240	Pump to Jack, Left Rear	2	Orange	7295	
Hose, 180	Pump to Jack, Right Front	2	White	7296	
Hose, 280	Pump to Jack, Right Rear	2	Yellow	7297	
Hose, N/A	Pump to Flow Divider	N/A	Green	N/A	N/A
Hose, N/A	Flow divider to front slide, Room 1	N/A	Green	N/A	N/A
Hose, N/A	Flow divider to rear slide, Room 1	N/A	Green	N/A	N/A
Hose, 32	Pump to Room 1	2	Green	7298	127 / Drivers Side
Hose, N/A	Pump to Room 2	N/A	Purple	N/A	N/A
Hose, N/A	Pump to Room 3	N/A	Gray	N/A	N/A
Hose, N/A	Pump to Room 4	N/A	Red	N/A	N/A
Hose, N/A	Pump to Generator Slide	N/A		N/A	N/A
Travel Clamp	Two per Slide	N/A		HWH	N/A

Options

Revisions

**34N HURRICANE (19.5) TIRES
EQUALIZER JACKS (FULLY AUTOMATIC)
STANDARD ON THIS UNIT**

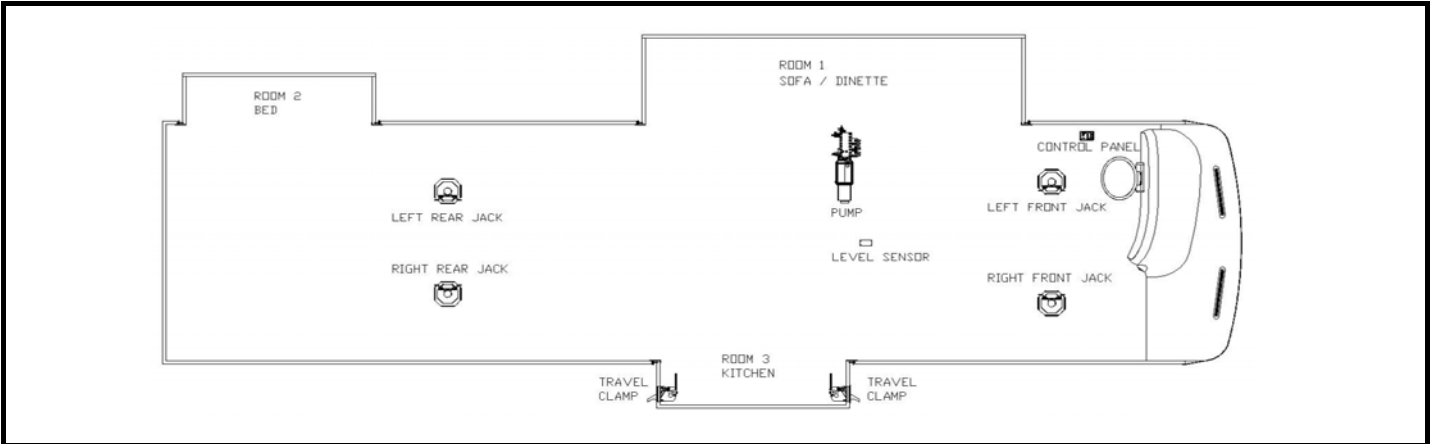

Notes:

- 1) Jacks mount in two different locations on bracket depending on tire size of chassis.
 - a) 19.5 Tires: Top hole in jack to top hole in bracket. Use 4 bolts in welded area of bracket.
 - b) 22.5 Tires: Top hole in jack to second hole in bracket. Use 6 bolts, 4 in welded area of bracket & 2 below welded area.

Item, Length	Description / Location	Qty	Color	Vendor PN		
Kit	(Items listed below)	1		8269	Measuring from inside of firewall, this is the end location of the hydraulic hoses where they attach to the slide mechanism.	
Pump	7-Function, 3 Rooms, Jacks	1		7301		
Jack	12,000 lbs, 16" Stroke	4		7214		
Control Panel	Located to the left of the drivers seat	1		2057		
Level Sensor	Attached to bottom of structure	1		7196		
Flow Divider	Mounted inside pump compartment	N/A		N/A		
Hose, 140	Pump to Jack, Left Front	2	Brown	7294		
Hose, 240	Pump to Jack, Left Rear	2	Orange	7295		
Hose, 180	Pump to Jack, Right Front	2	White	7296		
Hose, 280	Pump to Jack, Right Rear	2	Yellow	7297		
Hose, N/A	Pump to Flow Divider	N/A	Green	N/A		N/A
Hose, N/A	Flow divider to front slide, Room 1	N/A	Green	N/A		N/A
Hose, N/A	Flow divider to rear slide, Room 1	N/A	Green	N/A		N/A
Hose, 32	Pump to Room 1	2	Green	7298		127 / Drivers Side
Hose, 364	Pump to Room 2	2	Purple	7300	305 / Passenger Side	
Hose w90, 110	Pump to Room 3	2	Gray	7299	160 / Passenger Side	
Hose, N/A	Pump to Room 4	N/A	Red	N/A	N/A	
Hose, N/A	Pump to Generator Slide	N/A		N/A	N/A	
Travel Clamp	Two per Slide	N/A		HWH	N/A	

Options

Revisions

**30F HURRICANE (19.5) TIRES
EQUALIZER JACKS (FULLY AUTOMATIC)
STANDARD ON THIS UNIT**

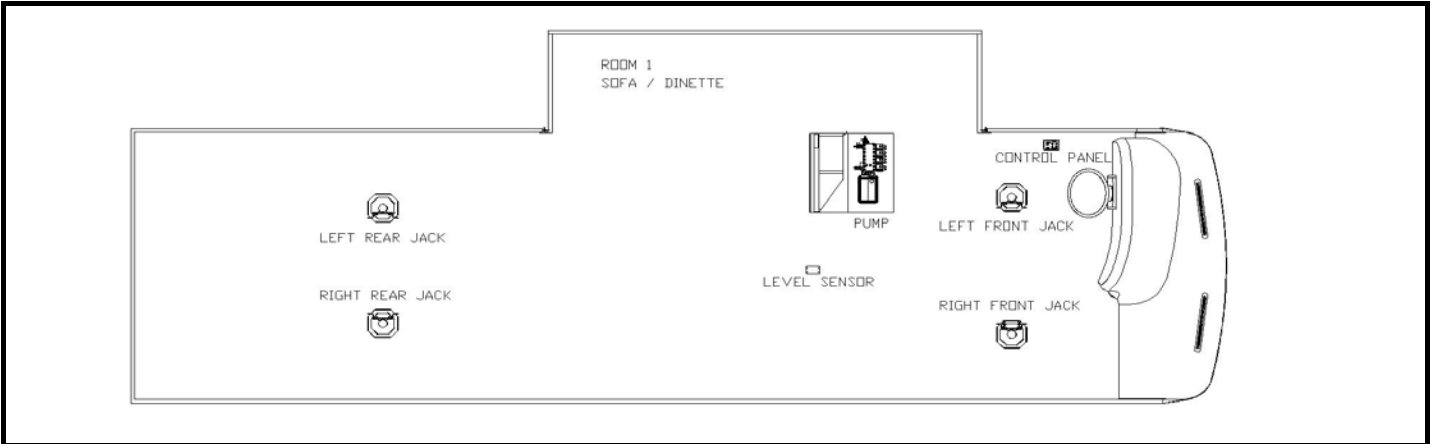

Notes:

- 1) Jacks mount in two different locations on bracket depending on tire size of chassis.
 - a) 19.5 Tires: Top hole in jack to top hole in bracket.
 - b) 22.5 Tires: Bottom hole in jack to bottom hole in bracket.

Item, Length	Description / Location	Qty	Color	Vendor PN		
Kit	(Items listed below)	1	N/A	8267	Measuring from inside of firewall, this is the end location of the hydraulic hoses where they attach to the slide mechanism.	
Pump	5-Function, 1 Room, Jacks	1	N/A	7242		
Jack	12,000 lbs, 16" Stroke	4	N/A	7214		
Control Panel	Located to the left of the drivers seat	1	N/A	2057		
Level Sensor	Attached to bottom of structure	1	N/A	7196		
Flow Divider	Mounted inside pump compartment	N/A	N/A	N/A		
Hose, 140	Pump to Jack, Left Front	2	Brown	7294		
Hose, 240	Pump to Jack, Left Rear	2	Orange	7295		
Hose, 180	Pump to Jack, Right Front	2	White	7296		
Hose, 280	Pump to Jack, Right Rear	2	Yellow	7297		
Hose, N/A	Pump to Flow Divider	N/A	TBD	N/A		N/A
Hose, N/A	Flow divider to front slide, Room 1	N/A	TBD	N/A		N/A
Hose, N/A	Flow divider to rear slide, Room 1	N/A	TBD	N/A		N/A
Hose, 48	Pump to Room 1	2	Green	TBD		127 / Drivers Side
Hose, N/A	Pump to Room 2	N/A	Purple	N/A	N/A	
Hose, N/A	Pump to Room 3	N/A	Gray	N/A	N/A	
Hose, N/A	Pump to Room 4	N/A	Red	N/A	N/A	
Hose, N/A	Pump to Generator Slide	N/A	TBD	N/A	N/A	
Travel Clamp	Two per Slide	N/A	N/A	HWH	N/A	

Options

Revisions

1	Change hose length fro room 1 from 32 to 48 (10/19/05 MJK)

**30Q HURRICANE (19.5) TIRES
EQUALIZER JACKS (FULLY AUTOMATIC)
OPTIONAL ON THIS UNIT**



Notes:

- 1) Jacks mount in two different locations on bracket depending on tire size of chassis.
 - a) 19.5 Tires: Top hole in jack to top hole in bracket.
 - b) 22.5 Tires: Bottom hole in jack to bottom hole in bracket.

Item, Length	Description / Location	Qty	Color	Vendor PN		
Kit	(Items listed below)	1	N/A	8252	Measuring from inside of firewall, this is the end location of the hydraulic hoses where they attach to the slide mechanism.	
Pump	4-Function, Jacks	1	N/A	7239		
Jack	12,000 lbs, 16" Stroke	4	N/A	7214		
Control Panel	Located to the left of the drivers seat	1	N/A	2057		
Level Sensor	Attached to bottom of structure	1	N/A	7196		
Flow Divider	Mounted inside pump compartment	N/A	N/A	N/A		
Hose, 140	Pump to Jack, Left Front	2	Brown	7294		
Hose, 240	Pump to Jack, Left Rear	2	Orange	7295		
Hose, 180	Pump to Jack, Right Front	2	White	7296		
Hose, 280	Pump to Jack, Right Rear	2	Yellow	7297		
Hose, N/A	Pump to Flow Divider	N/A	TBD	N/A		N/A
Hose, N/A	Flow divider to front slide, Room 1	N/A	TBD	N/A		N/A
Hose, N/A	Flow divider to rear slide, Room 1	N/A	TBD	N/A		N/A
Hose, N/A	Pump to Room 1	N/A	Green	N/A		N/A
Hose, N/A	Pump to Room 2	N/A	Purple	N/A	N/A	
Hose, N/A	Pump to Room 3	N/A	Gray	N/A	N/A	
Hose, N/A	Pump to Room 4	N/A	Red	N/A	N/A	
Hose, N/A	Pump to Generator Slide	N/A	TBD	N/A	N/A	
Travel Clamp	Two per Slide	N/A	N/A	HWH	N/A	

Options

Revisions

**31D HURRICANE (19.5) TIRES
EQUALIZER JACKS (FULLY AUTOMATIC)
OPTIONAL ON THIS UNIT**

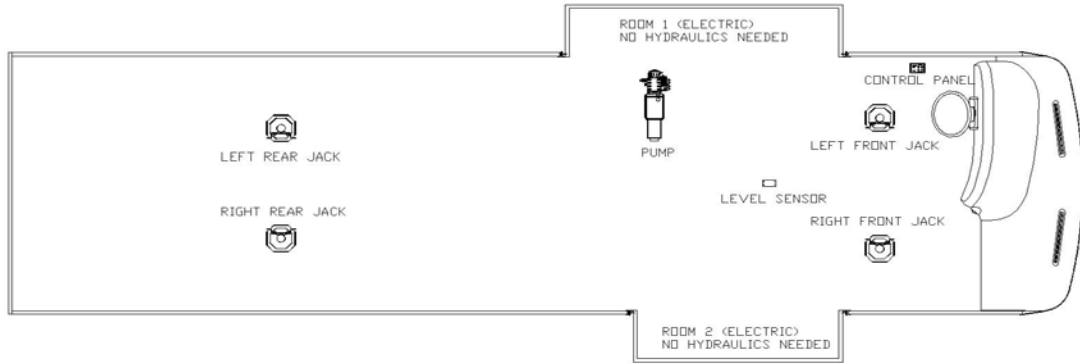

Notes:

- 1) Jacks mount in two different locations on bracket depending on tire size of chassis.
 - a) 19.5 Tires: Top hole in jack to top hole in bracket.
 - b) 22.5 Tires: Bottom hole in jack to bottom hole in bracket.

Item, Length	Description / Location	Qty	Color	Vendor PN		
Kit	(Items listed below)	1	N/A	8252	Measuring from inside of firewall, this is the end location of the hydraulic hoses where they attach to the slide mechanism.	
Pump	4-Function, Jacks	1	N/A	7239		
Jack	12,000 lbs, 16" Stroke	4	N/A	7214		
Control Panel	Located to the left of the drivers seat	1	N/A	2057		
Level Sensor	Attached to bottom of structure	1	N/A	7196		
Flow Divider	Mounted inside pump compartment	N/A	N/A	N/A		
Hose, 140	Pump to Jack, Left Front	2	Brown	7294		
Hose, 240	Pump to Jack, Left Rear	2	Orange	7295		
Hose, 180	Pump to Jack, Right Front	2	White	7296		
Hose, 280	Pump to Jack, Right Rear	2	Yellow	7297		
Hose, N/A	Pump to Flow Divider	N/A	TBD	N/A		N/A
Hose, N/A	Flow divider to front slide, Room 1	N/A	TBD	N/A		N/A
Hose, N/A	Flow divider to rear slide, Room 1	N/A	TBD	N/A		N/A
Hose, N/A	Pump to Room 1	N/A	Green	N/A		N/A
Hose, N/A	Pump to Room 2	N/A	Purple	N/A	N/A	
Hose, N/A	Pump to Room 3	N/A	Gray	N/A	N/A	
Hose, N/A	Pump to Room 4	N/A	Red	N/A	N/A	
Hose, N/A	Pump to Generator Slide	N/A	TBD	N/A	N/A	
Travel Clamp	Two per Slide	N/A	N/A	HWH	N/A	

Options

Revisions

**31H HURRICANE (19.5) TIRES
EQUALIZER JACKS (FULLY AUTOMATIC)
OPTIONAL ON THIS UNIT**

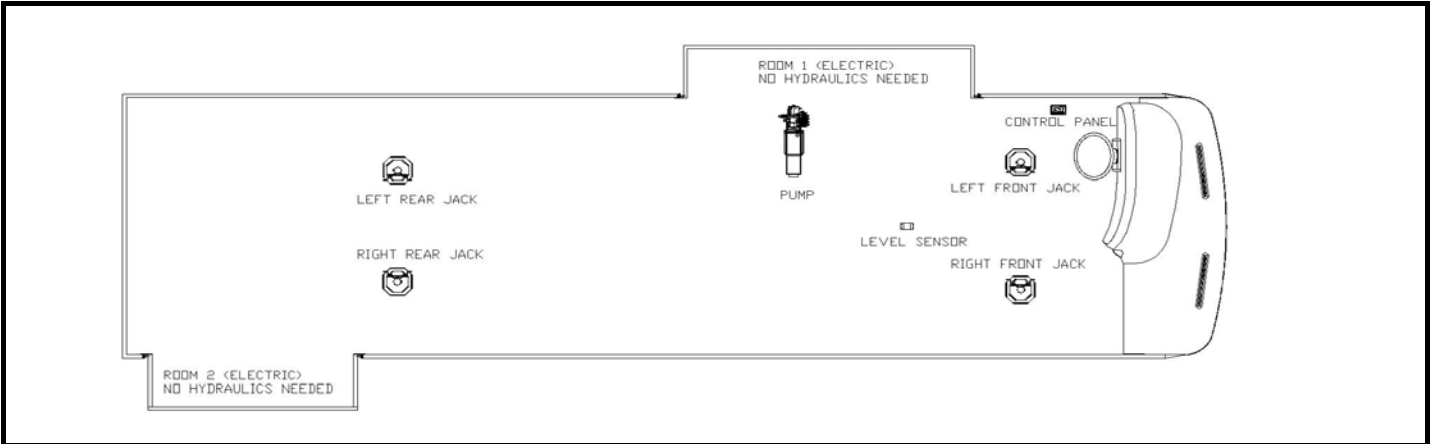

Notes:

1) Jacks mount in two different locations on bracket depending on tire size of chassis.

a) 19.5 Tires: Top hole in jack to top hole in bracket.

b) 22.5 Tires: Bottom hole in jack to bottom hole in bracket.

Item, Length	Description / Location	Qty	Color	Vendor PN		
Kit	(Items listed below)	1	N/A	8252	Measuring from inside of firewall, this is the end location of the hydraulic hoses where they attach to the slide mechanism.	
Pump	4-Function, Jacks	1	N/A	7239		
Jack	12,000 lbs, 16" Stroke	4	N/A	7214		
Control Panel	Located to the left of the drivers seat	1	N/A	2057		
Level Sensor	Attached to bottom of structure	1	N/A	7196		
Flow Divider	Mounted inside pump compartment	N/A	N/A	N/A		
Hose, 140	Pump to Jack, Left Front	2	Brown	7294		
Hose, 240	Pump to Jack, Left Rear	2	Orange	7295		
Hose, 180	Pump to Jack, Right Front	2	White	7296		
Hose, 280	Pump to Jack, Right Rear	2	Yellow	7297		
Hose, N/A	Pump to Flow Divider	N/A	TBD	N/A		N/A
Hose, N/A	Flow divider to front slide, Room 1	N/A	TBD	N/A		N/A
Hose, N/A	Flow divider to rear slide, Room 1	N/A	TBD	N/A		N/A
Hose, N/A	Pump to Room 1	N/A	Green	N/A		N/A
Hose, N/A	Pump to Room 2	N/A	Purple	N/A	N/A	
Hose, N/A	Pump to Room 3	N/A	Gray	N/A	N/A	
Hose, N/A	Pump to Room 4	N/A	Red	N/A	N/A	
Hose, N/A	Pump to Generator Slide	N/A	TBD	N/A	N/A	
Travel Clamp	Two per Slide	N/A	N/A	HWH	N/A	

Options

Revisions

**32R HURRICANE (19.5) TIRES
EQUALIZER JACKS (FULLY AUTOMATIC)
STANDARD ON THIS UNIT**

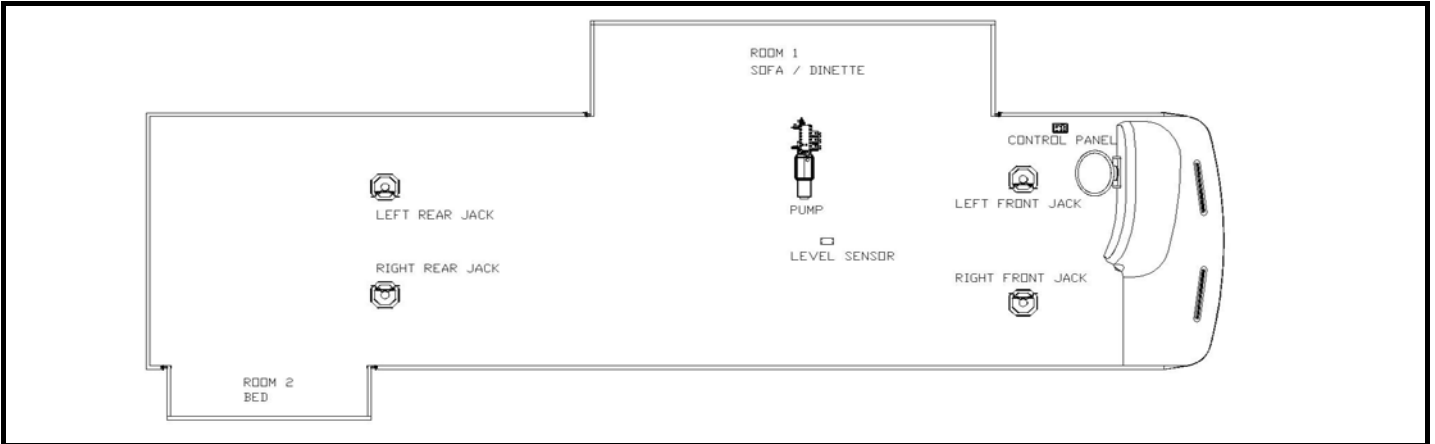

Notes:

- 1) Jacks mount in two different locations on bracket depending on tire size of chassis.
 - a) 19.5 Tires: Top hole in jack to top hole in bracket.
 - b) 22.5 Tires: Bottom hole in jack to bottom hole in bracket.

Item, Length	Description / Location	Qty	Color	Vendor PN		
Kit	(Items listed below)	1	N/A	8254	Measuring from inside of firewall, this is the end location of the hydraulic hoses where they attach to the slide mechanism.	
Pump	6-Function, 2 Rooms, Jacks	1	N/A	7243		
Jack	12,000 lbs, 16" Stroke	4	N/A	7214		
Control Panel	Located to the left of the drivers seat	1	N/A	2057		
Level Sensor	Attached to bottom of structure	1	N/A	7196		
Flow Divider	Mounted inside pump compartment	N/A	N/A	N/A		
Hose, 140	Pump to Jack, Left Front	2	Brown	7294		
Hose, 240	Pump to Jack, Left Rear	2	Orange	7295		
Hose, 180	Pump to Jack, Right Front	2	White	7296		
Hose, 280	Pump to Jack, Right Rear	2	Yellow	7297		
Hose, N/A	Pump to Flow Divider	N/A	TBD	N/A		N/A
Hose, N/A	Flow divider to front slide, Room 1	N/A	TBD	N/A		N/A
Hose, N/A	Flow divider to rear slide, Room 1	N/A	TBD	N/A		N/A
Hose, 32	Pump to Room 1	2	Green	7298		127 / Drivers Side
Hose, 364	Pump to Room 2	2	Purple	7300		305 / Passenger Side
Hose, N/A	Pump to Room 3	N/A	Gray	N/A	N/A	
Hose, N/A	Pump to Room 4	N/A	Red	N/A	N/A	
Hose, N/A	Pump to Generator Slide	N/A	TBD	N/A	N/A	
Travel Clamp	Two per Slide	N/A	N/A	HWH	N/A	

Options

Revisions

**33H HURRICANE (19.5) TIRES
EQUALIZER JACKS (FULLY AUTOMATIC)
STANDARD ON THIS UNIT**

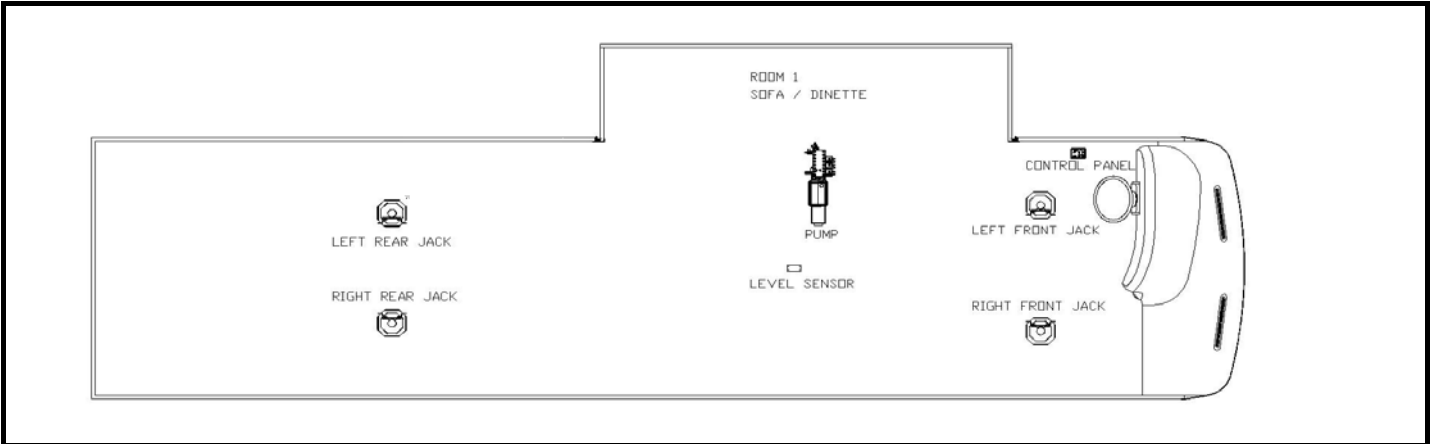

Notes:

- 1) Jacks mount in two different locations on bracket depending on tire size of chassis.
 - a) 19.5 Tires: Top hole in jack to top hole in bracket.
 - b) 22.5 Tires: Bottom hole in jack to bottom hole in bracket.

Item, Length	Description / Location	Qty	Color	Vendor PN		
Kit	(Items listed below)	1	N/A	8270	Measuring from inside of firewall, this is the end location of the hydraulic hoses where they attach to the slide mechanism.	
Pump	5-Function, 1 Room, Jacks	1	N/A	7242		
Jack	12,000 lbs, 16" Stroke	4	N/A	7214		
Control Panel	Located to the left of the drivers seat	1	N/A	2057		
Level Sensor	Attached to bottom of structure	1	N/A	7196		
Flow Divider	Mounted inside pump compartment	N/A	N/A	N/A		
Hose, 140	Pump to Jack, Left Front	2	Brown	7294		
Hose, 240	Pump to Jack, Left Rear	2	Orange	7295		
Hose, 180	Pump to Jack, Right Front	2	White	7296		
Hose, 280	Pump to Jack, Right Rear	2	Yellow	7297		
Hose, N/A	Pump to Flow Divider	N/A	TBD	N/A		N/A
Hose, N/A	Flow divider to front slide, Room 1	N/A	TBD	N/A		N/A
Hose, N/A	Flow divider to rear slide, Room 1	N/A	TBD	N/A		N/A
Hose, 32	Pump to Room 1	2	Green	7298		127 / Drivers Side
Hose, N/A	Pump to Room 2	N/A	Purple	N/A		N/A
Hose, N/A	Pump to Room 3	N/A	Gray	N/A	N/A	
Hose, N/A	Pump to Room 4	N/A	Red	N/A	N/A	
Hose, N/A	Pump to Generator Slide	N/A	TBD	N/A	N/A	
Travel Clamp	Two per Slide	N/A	N/A	HWH	N/A	

Options

Revisions

**34N HURRICANE (19.5) TIRES
EQUALIZER JACKS (FULLY AUTOMATIC)
STANDARD ON THIS UNIT**

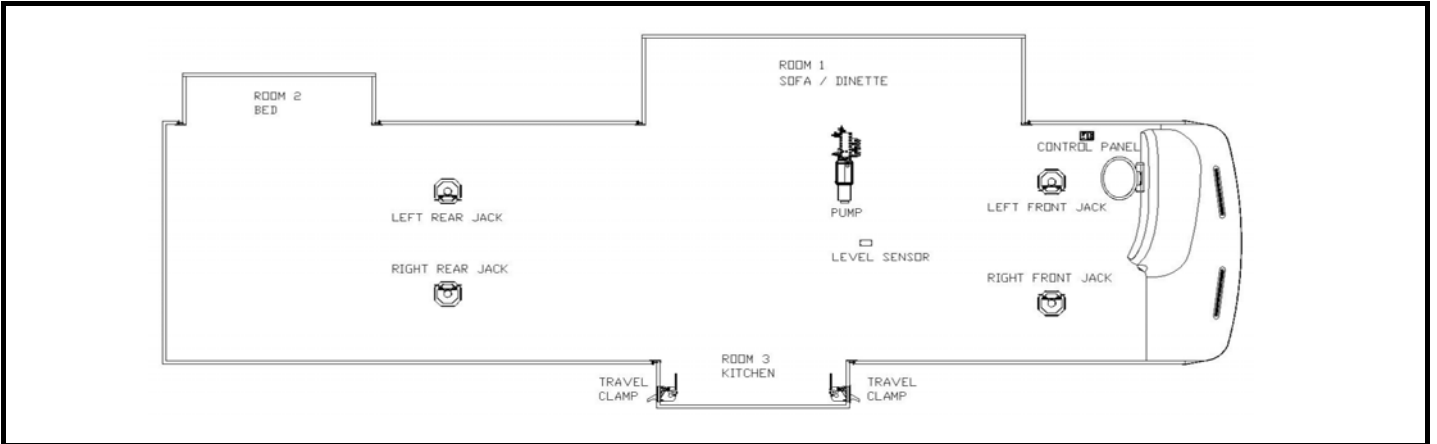

Notes:

- 1) Jacks mount in two different locations on bracket depending on tire size of chassis.
 - a) 19.5 Tires: Top hole in jack to top hole in bracket.
 - b) 22.5 Tires: Bottom hole in jack to bottom hole in bracket.

Item, Length	Description / Location	Qty	Color	Vendor PN		
Kit	(Items listed below)	1	N/A	8269	Measuring from inside of firewall, this is the end location of the hydraulic hoses where they attach to the slide mechanism.	
Pump	7-Function, 3 Rooms, Jacks	1	N/A	7301		
Jack	12,000 lbs, 16" Stroke	4	N/A	7214		
Control Panel	Located to the left of the drivers seat	1	N/A	2057		
Level Sensor	Attached to bottom of structure	1	N/A	7196		
Flow Divider	Mounted inside pump compartment	N/A	N/A	N/A		
Hose, 140	Pump to Jack, Left Front	2	Brown	7294		
Hose, 240	Pump to Jack, Left Rear	2	Orange	7295		
Hose, 180	Pump to Jack, Right Front	2	White	7296		
Hose, 280	Pump to Jack, Right Rear	2	Yellow	7297		
Hose, N/A	Pump to Flow Divider	N/A	TBD	N/A		N/A
Hose, N/A	Flow divider to front slide, Room 1	N/A	TBD	N/A		N/A
Hose, N/A	Flow divider to rear slide, Room 1	N/A	TBD	N/A		N/A
Hose, 32	Pump to Room 1	2	Green	7298		127 / Drivers Side
Hose, 364	Pump to Room 2	2	Purple	7300	305 / Passenger Side	
Hose, 110	Pump to Room 3	2	Gray	7299	160 / Passenger Side	
Hose, N/A	Pump to Room 4	N/A	Red	N/A	N/A	
Hose, N/A	Pump to Generator Slide	N/A	TBD	N/A	N/A	
Travel Clamp	Two per Slide	N/A	N/A	HWH	N/A	

Options

Revisions

36A Valencia
EQUALIZER JACKS (FULLY AUTOMATIC)
STANDARD ON THIS UNIT

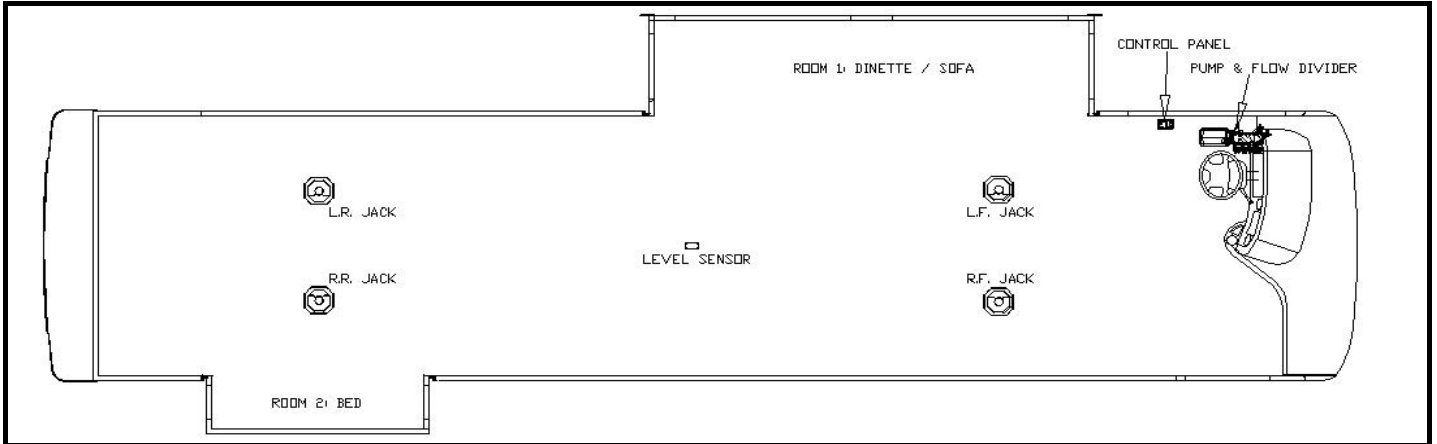

Notes:

- 1) Jacks mount to chassis brackets with the lowest holes of the jacks aligned with the lowest holes of the mounting brackets.
- 2) Level sensor attaches to bottom of structure; on lower hat section flanges or square tube.
- 3) Hydraulic hose terminations for room #1 require 90 degree swivel elbows.
- 4) Reference FM-3991 for a better visual of Room 1 hydraulic connections.

Item, Length	Description / Location	Qty	Color	Vendor PN	
Kit	(Items listed below)	1		8279	
Pump	6-Function, 2 Rooms & Jacks	1		7318	
Jack	17,000 lbs, 18" Stroke	4		7134	
Control Panel	Located to the left of the drivers seat	1		2057	
Level Sensor	Attached to bottom of structure	1		7196	
Sync Cylinder	Mounted	1		7351	
Hose, 126	Pump to Jack, Left Front	2	Brown	7246	
Hose, 364	Pump to Jack, Left Rear	2	Orange	7307	
Hose, 140	Pump to Jack, Right Front	2	White	7308	
Hose, 364	Pump to Jack, Right Rear	2	Yellow	7309	
Hose, 140	Pump to synchronizing manifold	2	Green	7311	Mounts to bracket on structure
Hose w90, 170	Sync cylinder to front slide, Room 1	2	Green	2415	103 / Drivers side
Hose w90, 170	Sync cylinder to rear slide, Room 1	2	Green	2415	196 / Drivers side
	Pump to Room 1	N/A	Green		
Hose, 450	Pump to Room 2	2	Purple	TBD	325 / Drivers Side
	Pump to Room 3		Gray		
	Pump to Room 4		Red		
	Pump to Generator Slide	N/A			N/A
Travel Clamp	(two per slide, except the bed slide)	2		HWH	N/A

Measuring from inside of firewall, this is the end location of the hydraulic hoses where they attach to the slide mechanism.

Options

Item, Length	Description / Location	Qty	Color	Vendor PN	

Revisions

1	ECN #3714, added the note on hose fittings for the 3" in floor slide (now 90 degree fittings)
2	ECN #3772, changed dinette slide hoses to mech 2, now 16" longer for routing
3	ECN #3845, flow divider is replaced by the synchronizing cylinder (all field units as well)

37A Valencia
EQUALIZER JACKS (FULLY AUTOMATIC)
STANDARD ON THIS UNIT

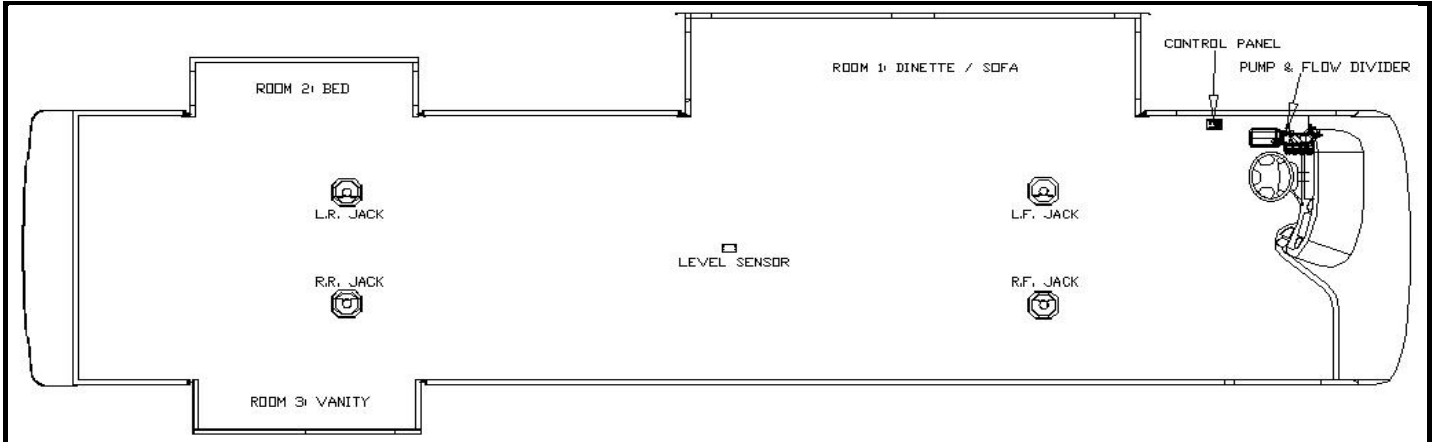

Notes:

- 1) Jacks mount to chassis brackets with the lowest holes of the jacks aligned with the lowest holes of the mounting brackets.
- 2) Level sensor attaches to bottom of structure; on lower hat section flanges or square tube.
- 3) Hydraulic hose terminations for room #1 & #3 require 90 degree swivel elbows.
- 4) Reference FM-3991 for a better visual of Room 1 hydraulic connections.

Item, Length	Description / Location	Qty	Color	Vendor PN	
Kit	(Items listed below)	1		8280	
Pump	7-Function, 3 Rooms & Jacks	1		7319	
Jack	17,000 lbs, 18" Stroke	4		7134	
Control Panel	Located to the left of the drivers seat	1		2057	
Level Sensor	Attached to bottom of structure	1		7196	
Sync Cylinder	Mounted inside pump compartment	1		7351	
Hose, 126	Pump to Jack, Left Front	2	Brown	7246	
Hose, 364	Pump to Jack, Left Rear	2	Orange	7307	
Hose, 140	Pump to Jack, Right Front	2	White	7308	
Hose, 364	Pump to Jack, Right Rear	2	Yellow	7309	
Hose, 140	Pump to synchronizing manifold	2	Green	7311	Mounts to bracket on structure
Hose w90, 170	Sync cylinder to front slide, Room 1	2	Green	2415	103 / Drivers side
Hose w90, 170	Sync cylinder to rear slide, Room 1	2	Green	2415	196 / Drivers side
	Pump to Room 1	N/A	Green		
Hose, 420	Pump to Room 2	2	Purple	7313	325 / Drivers Side
Hose w90, 450	Pump to Room 3	2	Gray	7314	355 / Passenger Side
	Pump to Room 4	N/A	Red		
	Pump to Generator Slide	N/A			
Travel Clamp	(two per slide, except the bed slide)	4		HWH	N/A

Measuring from inside of firewall, this is the end location of the hydraulic hoses where they attach to the slide mechanism.

Options

Revisions

1	ECN #3714, added the note on hose fittings for the 3" in floor slide (now 90 degree fittings)
2	ECN #3772, changed dinette slide hoses to mech 2, now 16" longer for routing
3	ECN #3845, flow divider is replaced by the synchronizing cylinder (all field units as well)

38C Valencia
EQUALIZER JACKS (FULLY AUTOMATIC)
STANDARD ON THIS UNIT

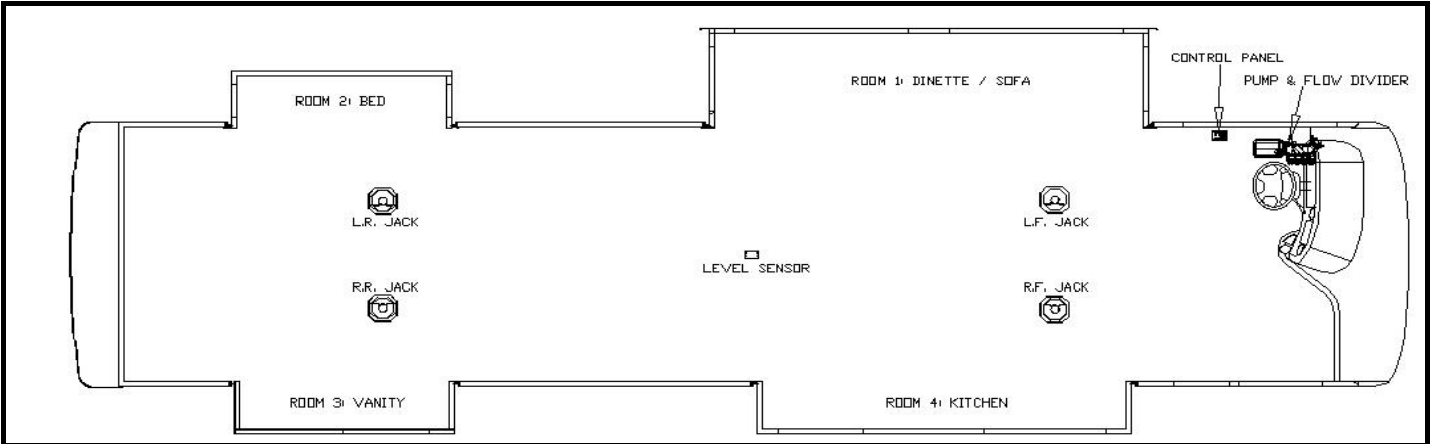

Notes:

- 1) Jacks mount to chassis brackets with the lowest holes of the jacks aligned with the lowest holes of the mounting brackets.
- 2) Level sensor attaches to bottom of structure; on lower hat section flanges or square tube.
- 3) Hydraulic hose terminations for room #1, #3, & #4 require 90 degree swivel elbows.
- 4) Reference FM-3991 for a better visual of Room 1 hydraulic connections.

Item, Length	Description / Location	Qty	Color	Vendor PN		
Kit	(Items listed below)	1		8278	Measuring from inside of firewall, this is the end location of the hydraulic hoses where they attach to the slide mechanism.	
Pump	8-Function, 4 Rooms & Jacks	1		7302		
Jack	17,000 lbs, 18" Stroke	4		7134		
Control Panel	Located to the left of the drivers seat	1		2057		
Level Sensor	Attached to bottom of structure	1		7196		
Sync Cylinder	Mounted	1		7351		
Hose, 126	Pump to Jack, Left Front	2	Brown	7246		
Hose, 364	Pump to Jack, Left Rear	2	Orange	7307		
Hose, 140	Pump to Jack, Right Front	2	White	7308		
Hose, 364	Pump to Jack, Right Rear	2	Yellow	7309		
Hose, 140	Pump to synchronizing manifold	2	Green	7311		
Hose w90, 170	Sync cylinder to front slide, Room 1	2	Green	2415		103 / Drivers side
Hose w90, 170	Sync cylinder to rear slide, Room 1	2	Green	2415		196 / Drivers side
	Pump to Room 1	N/A	Green			
Hose, 420	Pump to Room 2	2	Purple	7313	325 / Drivers Side	
Hose w90, 450	Pump to Room 3	2	Gray	7314	355 / Passenger Side	
Hose w90, 200	Pump to Room 4	2	Red	7315	146 / Passenger Side	
	Pump to Generator Slide	N/A			N/A	
Travel Clamp	(two per slide, except the bed slide)	6		HWH	N/A	

Options

Item, Length	Description / Location	Qty	Color	Vendor PN	

Revisions

1	ECN #3714, added the note on hose fittings for the 3" in floor slide (now 90 degree fittings)
2	ECN #3772, changed dinette slide hoses to mech 2, now 16" longer for routing
3	ECN #3845, flow divider is replaced by the synchronizing cylinder (all field units as well)

36A Valencia
EQUALIZER JACKS (FULLY AUTOMATIC)
STANDARD ON THIS UNIT

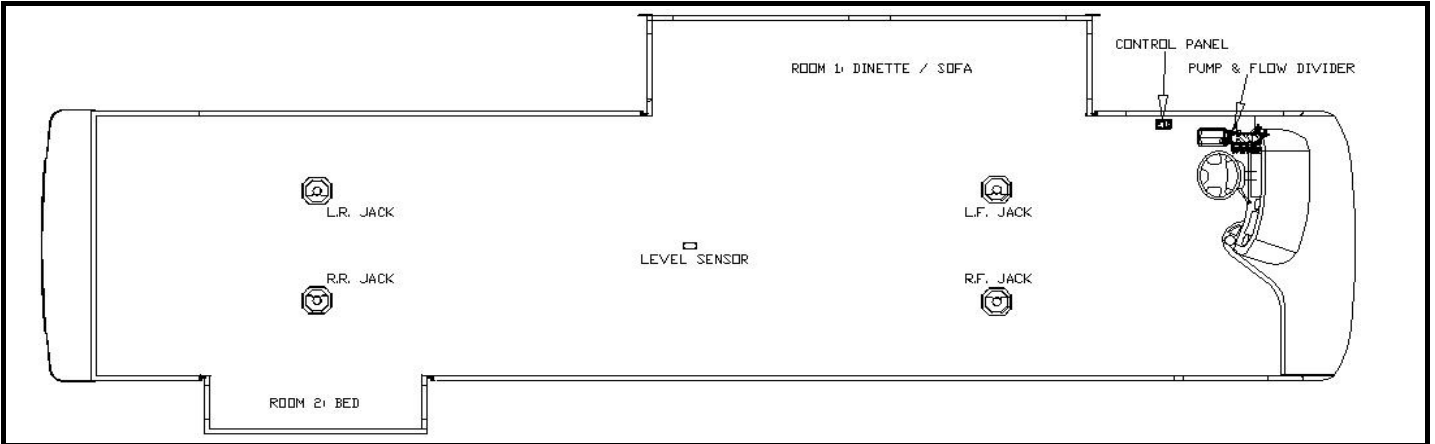

Notes:

- 1) Jacks mount to chassis brackets with the lowest holes of the jacks aligned with the lowest holes of the mounting brackets.
- 2) Level sensor attaches to bottom of structure; on lower hat section flanges or square tube.
- 3) Hydraulic hose terminations for room #1 require 90 degree swivel elbows.
- 4) Reference FM-3991 for a better visual of Room 1 hydraulic connections.

Item, Length	Description / Location	Qty	Color	Vendor PN	
Kit	(Items listed below)	1		8279	Measuring from inside of firewall, this is the end location of the hydraulic hoses where they attach to the slide mechanism.
Pump	6-Function, 2 Rooms & Jacks	1		7318	
Jack	17,000 lbs, 18" Stroke	4		7134	
Control Panel	Located to the left of the drivers seat	1		2057	
Level Sensor	Attached to bottom of structure	1		7196	
Sync Cylinder	Mounted	1		7351	
Hose, 126	Pump to Jack, Left Front	2	Brown	7246	
Hose, 364	Pump to Jack, Left Rear	2	Orange	7307	
Hose, 140	Pump to Jack, Right Front	2	White	7308	
Hose, 364	Pump to Jack, Right Rear	2	Yellow	7309	
Hose, 140	Pump to synchronizing manifold	2	Green	7311	Mounts to bracket on structure
Hose w90, 170	Sync cylinder to front slide, Room 1	2	Green	2415	103 / Drivers side
Hose w90, 170	Sync cylinder to rear slide, Room 1	2	Green	2415	196 / Drivers side
	Pump to Room 1	N/A	Green		
Hose, 450	Pump to Room 2	2	Purple	TBD	325 / Passenger Side
	Pump to Room 3		Gray		
	Pump to Room 4		Red		
	Pump to Generator Slide	N/A			N/A
Travel Clamp	(two per slide, except the bed slide)	2		HWH	N/A

Options

Item, Length	Description / Location	Qty	Color	Vendor PN	

Revisions

1	ECN #3714, added the note on hose fittings for the 3" in floor slide (now 90 degree fittings)
2	ECN #3772, changed dinette slide hoses to mech 2, now 16" longer for routing
3	ECN #3845, flow divider is replaced by the synchronizing cylinder (all field units as well)

36B Valencia
EQUALIZER JACKS (FULLY AUTOMATIC)
STANDARD ON THIS UNIT

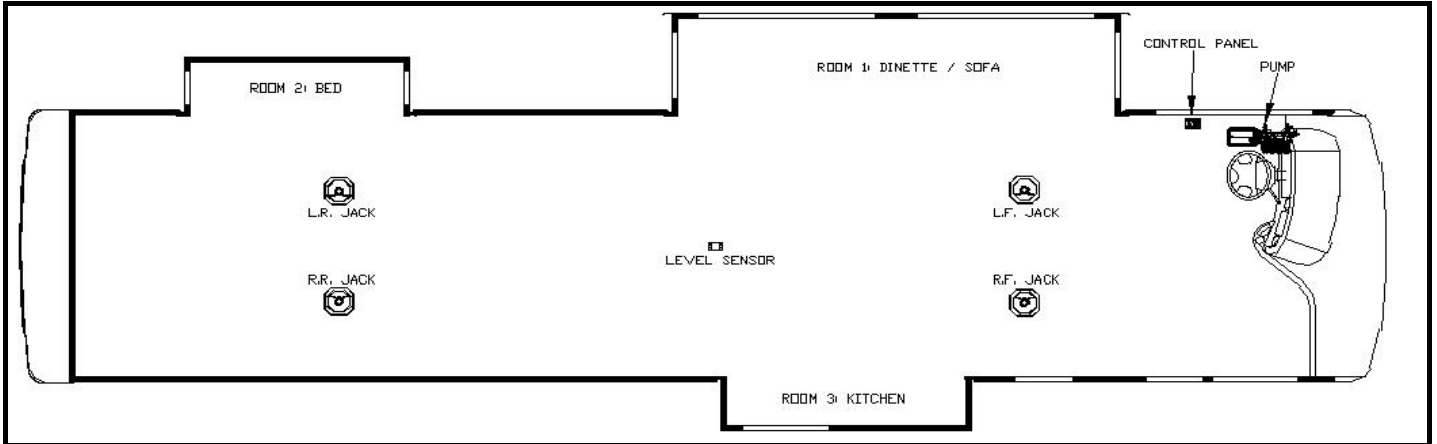

Notes:

- 1) Jacks mount to chassis brackets with the lowest holes of the jacks aligned with the lowest holes of the mounting brackets.
- 2) Level sensor attaches to bottom of structure; on lower hat section flanges or square tube.
- 3) Hydraulic hose terminations for room #1 & #3 require 90 degree swivel elbows.
- 4) Reference FM-3991 for a better visual of Room 1 hydraulic connections.

Item, Length	Description / Location	Qty	Color	Vendor PN		
Kit	(Items listed below)	1		8310	Measuring from inside of firewall, this is the end location of the hydraulic hoses where they attach to the slide mechanism.	
Pump	7-Function, 3 Rooms & Jacks	1		7319		
Jack	17,000 lbs, 18" Stroke	4		7134		
Control Panel	Located to the left of the drivers seat	1		2057		
Level Sensor	Attached to bottom of structure	1		7196		
Sync Cylinder	Mounted	1		7351		
Hose, 126	Pump to Jack, Left Front	2	Brown	7246		
Hose, 364	Pump to Jack, Left Rear	2	Orange	7307		
Hose, 140	Pump to Jack, Right Front	2	White	7308		
Hose, 364	Pump to Jack, Right Rear	2	Yellow	7309		
Hose, 140	Pump to synchronizing manifold	2	Green	7311		Mounts to bracket on structure
Hose w90, 170	Sync cylinder to front slide, Room 1	2	Green	2415		103 / Drivers side
Hose w90, 170	Sync cylinder to rear slide, Room 1	2	Green	2415		196 / Drivers side
	Pump to Room 1	N/A	Green			
Hose, 420	Pump to Room 2	2	Purple	7313	325 / Drivers Side	
Hose w90, 200	Pump to Room 3	2	Red	7315	146 / Passenger Side	
	Pump to Room 4	N/A				
	Pump to Generator Slide	N/A			N/A	
Travel Clamp	(two per slide, except the bed slide)	4		HWH	N/A	

Options

Revisions

37A Valencia
EQUALIZER JACKS (FULLY AUTOMATIC)
STANDARD ON THIS UNIT

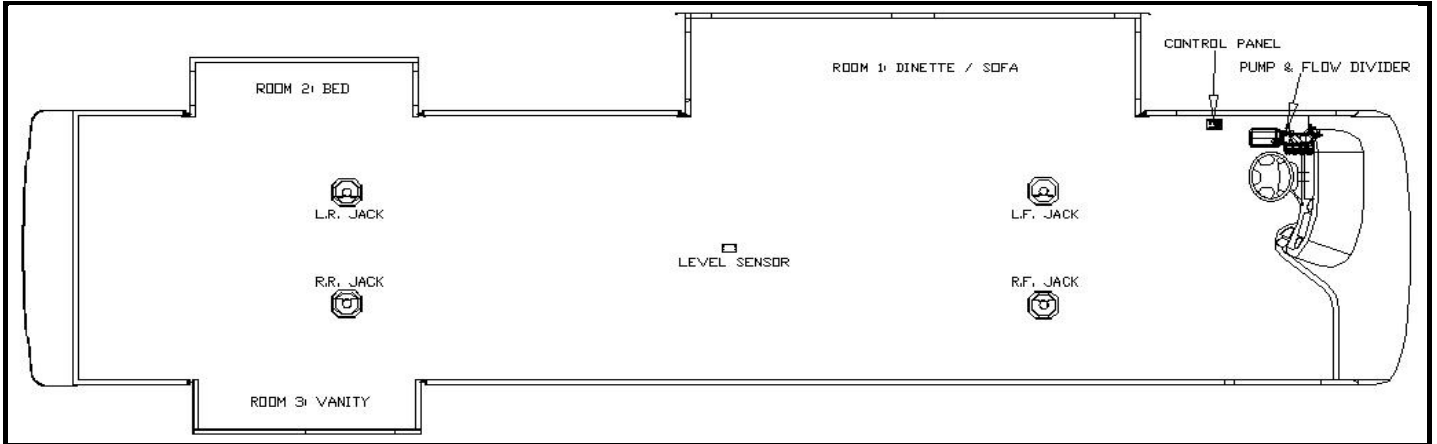

- Notes:**
- 1) Jacks mount to chassis brackets with the lowest holes of the jacks aligned with the lowest holes of the mounting brackets.
 - 2) Level sensor attaches to bottom of structure; on lower hat section flanges or square tube.
 - 3) Hydraulic hose terminations for room #1 & #3 require 90 degree swivel elbows.
 - 4) Reference FM-3991 for a better visual of Room 1 hydraulic connections.

Item, Length	Description / Location	Qty	Color	Vendor PN	
Kit	(Items listed below)	1		8280	
Pump	7-Function, 3 Rooms & Jacks	1		7319	
Jack	17,000 lbs, 18" Stroke	4		7134	
Control Panel	Located to the left of the drivers seat	1		2057	
Level Sensor	Attached to bottom of structure	1		7196	
Sync Cylinder	Mounted	1		7351	
Hose, 126	Pump to Jack, Left Front	2	Brown	7246	
Hose, 364	Pump to Jack, Left Rear	2	Orange	7307	
Hose, 140	Pump to Jack, Right Front	2	White	7308	
Hose, 364	Pump to Jack, Right Rear	2	Yellow	7309	
Hose, 140	Pump to synchronizing manifold	2	Green	7311	Mounts to bracket on structure
Hose w90, 170	Sync cylinder to front slide, Room 1	2	Green	2415	103 / Drivers side
Hose w90, 170	Sync cylinder to rear slide, Room 1	2	Green	2415	196 / Drivers side
	Pump to Room 1	N/A	Green		
Hose, 420	Pump to Room 2	2	Purple	7313	325 / Drivers Side
Hose w90, 450	Pump to Room 3	2	Gray	7314	355 / Passenger Side
	Pump to Room 4	N/A	Red		
	Pump to Generator Slide	N/A			
Travel Clamp	(two per slide, except the bed slide)	4		HWH	N/A

Measuring from inside of firewall, this is the end location of the hydraulic hoses where they attach to the slide mechanism.

Options

Revisions

1	ECN #3714, added the note on hose fittings for the 3" in floor slide (now 90 degree fittings)
2	ECN #3772, changed dinette slide hoses to mech 2, now 16" longer for routing
3	ECN #3845, flow divider is replaced by the synchronizing cylinder (all field units as well)

38C Valencia
EQUALIZER JACKS (FULLY AUTOMATIC)
STANDARD ON THIS UNIT

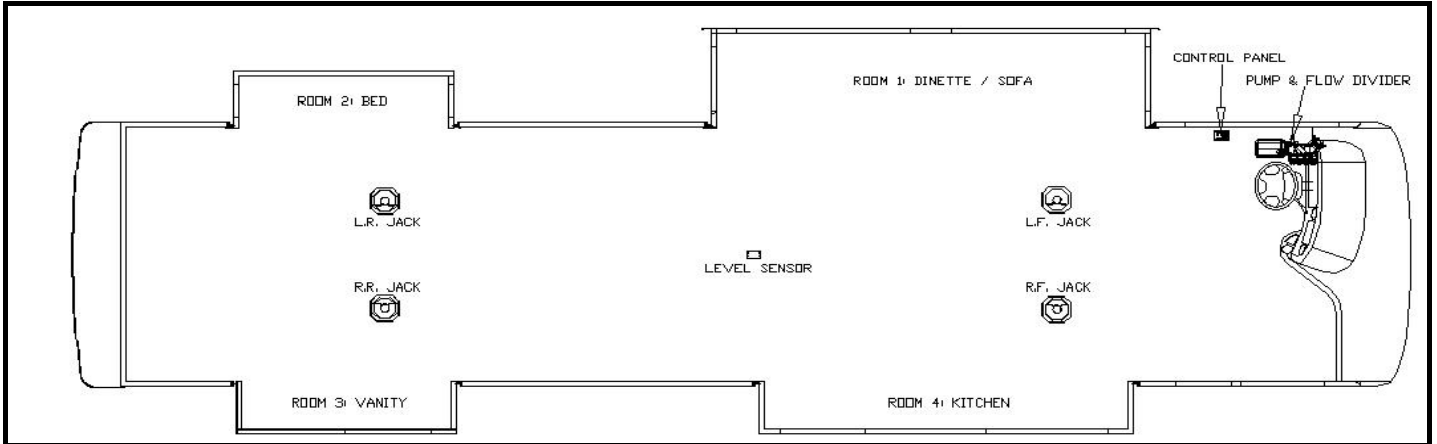

Notes:

- 1) Jacks mount to chassis brackets with the lowest holes of the jacks aligned with the lowest holes of the mounting brackets.
- 2) Level sensor attaches to bottom of structure; on lower hat section flanges or square tube.
- 3) Hydraulic hose terminations for room #1, #3, & #4 require 90 degree swivel elbows.
- 4) Reference FM-3991 for a better visual of Room 1 hydraulic connections.

Item, Length	Description / Location	Qty	Color	Vendor PN		
Kit	(Items listed below)	1		8278	Measuring from inside of firewall, this is the end location of the hydraulic hoses where they attach to the slide mechanism.	
Pump	8-Function, 4 Rooms & Jacks	1		7302		
Jack	17,000 lbs, 18" Stroke	4		7134		
Control Panel	Located to the left of the drivers seat	1		2057		
Level Sensor	Attached to bottom of structure	1		7196		
Sync Cylinder	Mounted	1		7351		
Hose, 126	Pump to Jack, Left Front	2	Brown	7246		
Hose, 364	Pump to Jack, Left Rear	2	Orange	7307		
Hose, 140	Pump to Jack, Right Front	2	White	7308		
Hose, 364	Pump to Jack, Right Rear	2	Yellow	7309		
Hose, 140	Pump to synchronizing manifold	2	Green	7311		Mounts to bracket on structure
Hose w90, 170	Sync cylinder to front slide, Room 1	2	Green	2415		103 / Drivers side
Hose w90, 170	Sync cylinder to rear slide, Room 1	2	Green	2415		196 / Drivers side
	Pump to Room 1	N/A	Green			
Hose, 420	Pump to Room 2	2	Purple	7313	325 / Drivers Side	
Hose w90, 450	Pump to Room 3	2	Gray	7314	355 / Passenger Side	
Hose w90, 200	Pump to Room 4	2	Red	7315	146 / Passenger Side	
	Pump to Generator Slide	N/A			N/A	
Travel Clamp	(two per slide, except the bed slide)	6		HWH	N/A	

Options

Item, Length	Description / Location	Qty	Color	Vendor PN	

Revisions

1	ECN #3714, added the note on hose fittings for the 3" in floor slide (now 90 degree fittings)
2	ECN #3772, changed dinette slide hoses to mech 2, now 16" longer for routing
3	ECN #3845, flow divider is replaced by the synchronizing cylinder (all field units as well)

**32B KODIAK (19.5) TIRES
EQUALIZER JACKS (FULLY AUTOMATIC)
OPTIONAL ON THIS UNIT**

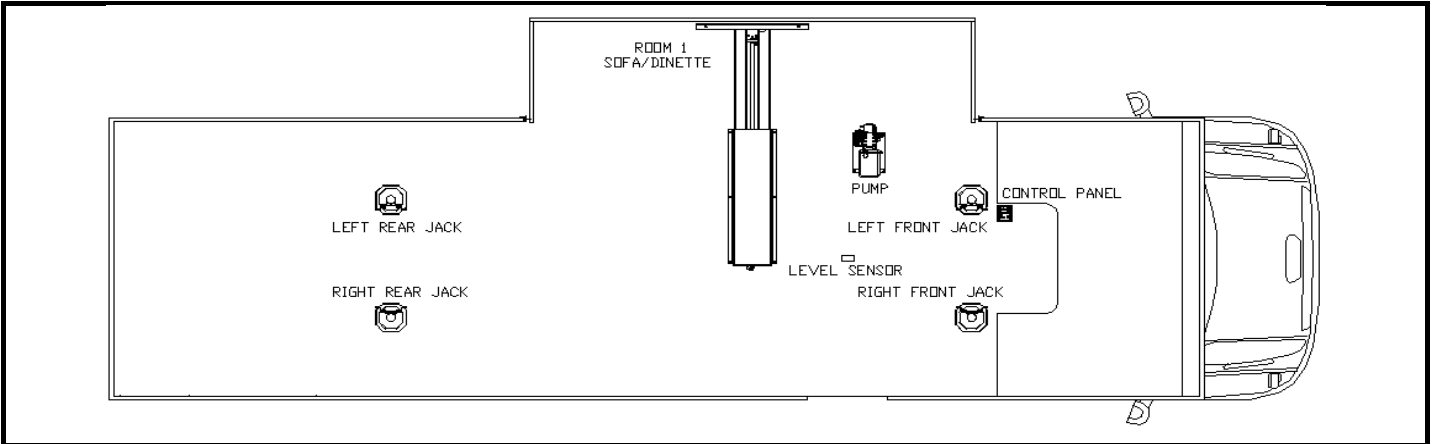

Notes:

1) Jacks mount 2nd hole from top to top mounting plate hole.

Item, Length	Description / Location	Qty	Color	Vendor PN	
Kit	(Items listed below)	1		8264	Measuring from back of cab floor, this is the end location of the hydraulic hoses where they attach to the slide mechanism.
Pump	5-Function, 1 Room, Jacks	1		7242	
Jack	12,000 lbs, 16" Stroke	4		7214	
Control Panel	Located to the right of the drivers seat	1		2057	
Level Sensor	Attached to bottom of structure	1		7196	
Flow Divider	Mounted inside pump compartment	N/A		N/A	
Hose, 84	Pump to Jack, Left Front	2	Brown	7287	
Hose, 256	Pump to Jack, Left Rear	2	Orange	7249	
Hose, 100	Pump to Jack, Right Front	2	White	7288	
Hose, 223	Pump to Jack, Right Rear	2	Yellow	7289	
Hose, N/A	Pump to Flow Divider	N/A	TBD	N/A	N/A
Hose, N/A	Flow divider to front slide, Room 1	N/A	TBD	N/A	N/A
Hose, N/A	Flow divider to rear slide, Room 1	N/A	TBD	N/A	N/A
Hose, 84	Pump to Room 1	2	Green	7254	80 / Drivers Side
Hose, N/A	Pump to Room 2	N/A	Purple	N/A	N/A
Hose, N/A	Pump to Room 3	N/A	Gray	N/A	N/A
Hose, N/A	Pump to Room 4	N/A	Red	N/A	N/A
Hose, N/A	Pump to Generator Slide	N/A	TBD	N/A	N/A
Travel Clamp	Two per Slide	N/A		HWH	N/A
Options					
Revisions	Description		By	Date	
1	Made Jack, Control Panel, Level Sensor & hoses standard		JB	11/17/2005	

**33K KODIAK (19.5) TIRES
EQUALIZER JACKS (FULLY AUTOMATIC)
OPTIONAL ON THIS UNIT**

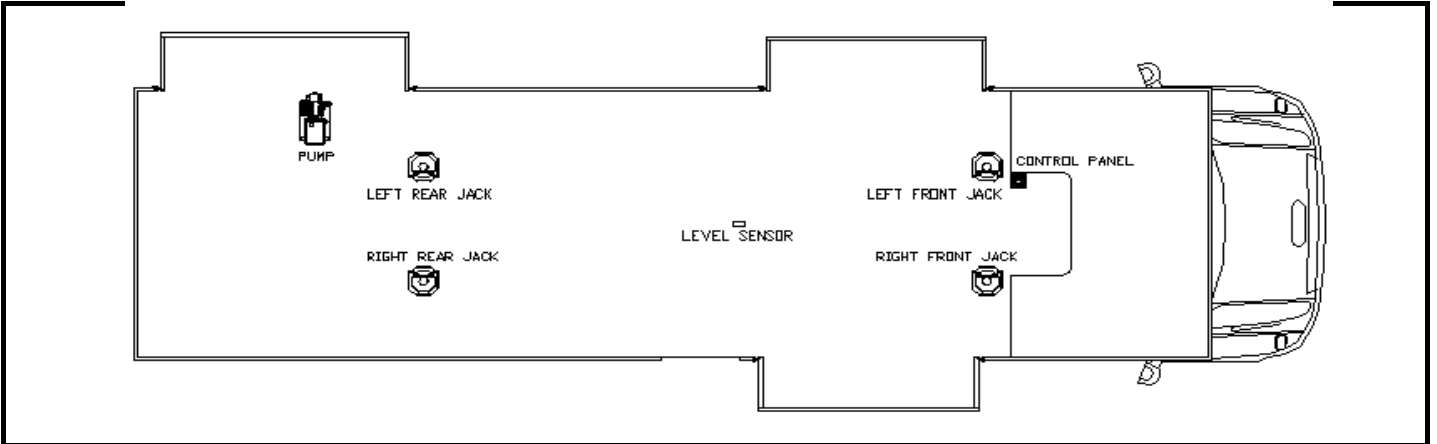

Notes:

1) Jacks mount 2nd hole from top to top mounting plate hole.

Item, Length	Description / Location	Qty	Color	Vendor PN	Measuring from back of cab floor, this is the end location of the hydraulic hoses where they attach to the slide mechanism.
Flow Divider	Mounted inside pump compartment	N/A		N/A	
Hose, N/A	Pump to Flow Divider	N/A	TBD	N/A	N/A
Hose, N/A	Flow divider to front slide, Room 1	N/A	TBD	N/A	N/A
Hose, N/A	Flow divider to rear slide, Room 1	N/A	TBD	N/A	N/A
Hose, N/A	Pump to Room 1	N/A	Green	N/A	N/A
Hose, N/A	Pump to Room 2	N/A	Purple	N/A	N/A
Hose, N/A	Pump to Room 3	N/A	Gray	N/A	N/A
Hose, N/A	Pump to Room 4	N/A	Red	N/A	N/A
Hose, N/A	Pump to Generator Slide	N/A	TBD	N/A	N/A
Travel Clamp	Two per Slide	N/A	N/A	HWH	N/A
Options					
Kit	(Items listed below)	1		8274	
Pump	4-Function, Jacks	1		7239	
Jack	12,000 lbs, 16" Stroke	4		7214	
Control Panel	Located to the right of the drivers seat	1		2057	
Level Sensor	Attached to bottom of structure	1		7196	
Hose, 300	Pump to Jack, Left Front	2	Brown	7247	
Hose, 100	Pump to Jack, Left Rear	2	Orange	7248	
Hose, 300	Pump to Jack, Right Front	2	White	7304	
Hose, 126	Pump to Jack, Right Rear	2	Yellow	7305	
Revisions					

**34G KODIAK (19.5) TIRES
EQUALIZER JACKS (FULLY AUTOMATIC)
OPTIONAL ON THIS UNIT**

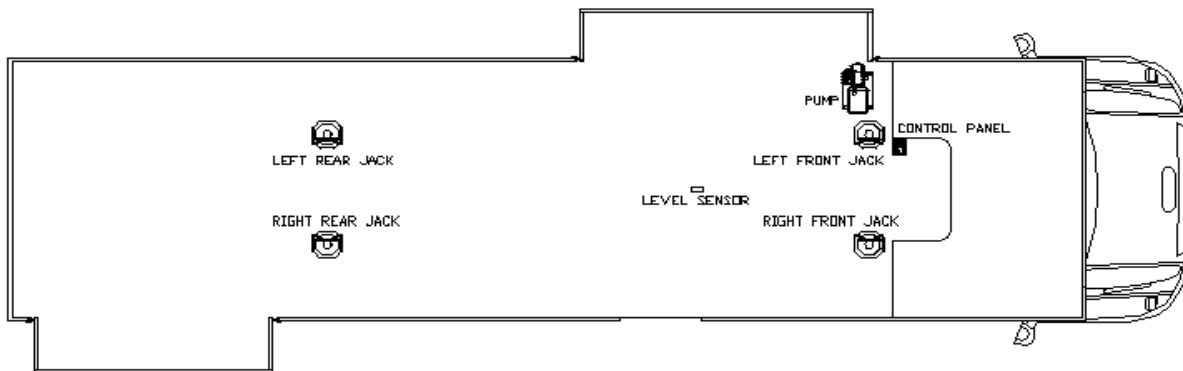

Notes:

1) Jacks mount 2nd hole from top to top mounting plate hole.

Item, Length	Description / Location	Qty	Color	Vendor PN	Measuring from back of cab floor, this is the end location of the hydraulic hoses where they attach to the slide mechanism.
Flow Divider	Mounted inside pump compartment	N/A		N/A	
Hose, N/A	Pump to Flow Divider	N/A	TBD	N/A	N/A
Hose, N/A	Flow divider to front slide, Room 1	N/A	TBD	N/A	N/A
Hose, N/A	Flow divider to rear slide, Room 1	N/A	TBD	N/A	N/A
Hose, N/A	Pump to Room 1	N/A	Green	N/A	N/A
Hose, N/A	Pump to Room 2	N/A	Purple	N/A	N/A
Hose, N/A	Pump to Room 3	N/A	Gray	N/A	N/A
Hose, N/A	Pump to Room 4	N/A	Red	N/A	N/A
Hose, N/A	Pump to Generator Slide	N/A	TBD	N/A	N/A
Travel Clamp	Two per Slide	N/A		HWH	N/A
Options					
Kit	(Items listed below)	1		8275	
Pump	4-Function, Jacks	1		7239	
Jack	12,000 lbs, 16" Stroke	4		7214	
Control Panel	Located to the right of the drivers seat	1		2057	
Level Sensor	Attached to bottom of structure	1		7196	
Hose, 84	Pump to Jack, Left Front	2	Brown	7287	
Hose, 256	Pump to Jack, Left Rear	2	Orange	7249	
Hose, 100	Pump to Jack, Right Front	2	White	7288	
Hose, 269	Pump to Jack, Right Rear	2	Yellow	7252	
Revisions					

**35B KODIAK (19.5) TIRES
EQUALIZER JACKS (FULLY AUTOMATIC)
OPTIONAL ON THIS UNIT**

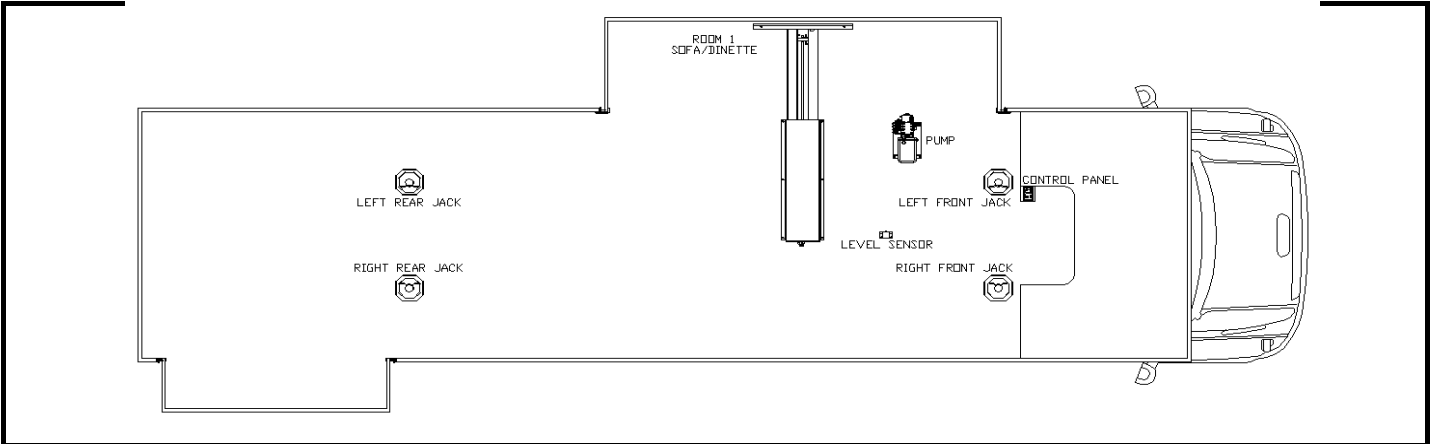

Notes:

1) Jacks mount 2nd hole from top to top mounting plate hole.

Item, Length	Description / Location	Qty	Color	Vendor PN	
Kit	(Items listed below)	1		8264	Measuring from back of cab floor, this is the end location of the hydraulic hoses where they attach to the slide mechanism.
Pump	5-Function, 1 Room, Jacks	1		7242	
Jack	12,000 lbs, 16" Stroke	4		7214	
Control Panel	Located to the right of the drivers seat	1		2057	
Level Sensor	Attached to bottom of structure	1		7196	
Flow Divider	Mounted inside pump compartment	N/A		N/A	
Hose, 84	Pump to Jack, Left Front	2	Brown	7287	
Hose, 240	Pump to Jack, Left Rear	2	Orange	7295	
Hose, 100	Pump to Jack, Right Front	2	White	7288	
Hose, 269	Pump to Jack, Right Rear	2	Yellow	7252	
Hose, N/A	Pump to Flow Divider	N/A	TBD	N/A	N/A
Hose, N/A	Flow divider to front slide, Room 1	N/A	TBD	N/A	N/A
Hose, N/A	Flow divider to rear slide, Room 1	N/A	TBD	N/A	N/A
Hose, 84	Pump to Room 1	2	Green	7254	80 / Drivers Side
Hose, N/A	Pump to Room 2	N/A	Purple	N/A	N/A
Hose, N/A	Pump to Room 3	N/A	Gray	N/A	N/A
Hose, N/A	Pump to Room 4	N/A	Red	N/A	N/A
Hose, N/A	Pump to Generator Slide	N/A	TBD	N/A	N/A
Travel Clamp	Two per Slide	N/A		HWH	N/A

Options

Revisions	Description	By	Date

**32B KODIAK (19.5) TIRES
EQUALIZER JACKS (FULLY AUTOMATIC)
OPTIONAL ON THIS UNIT**

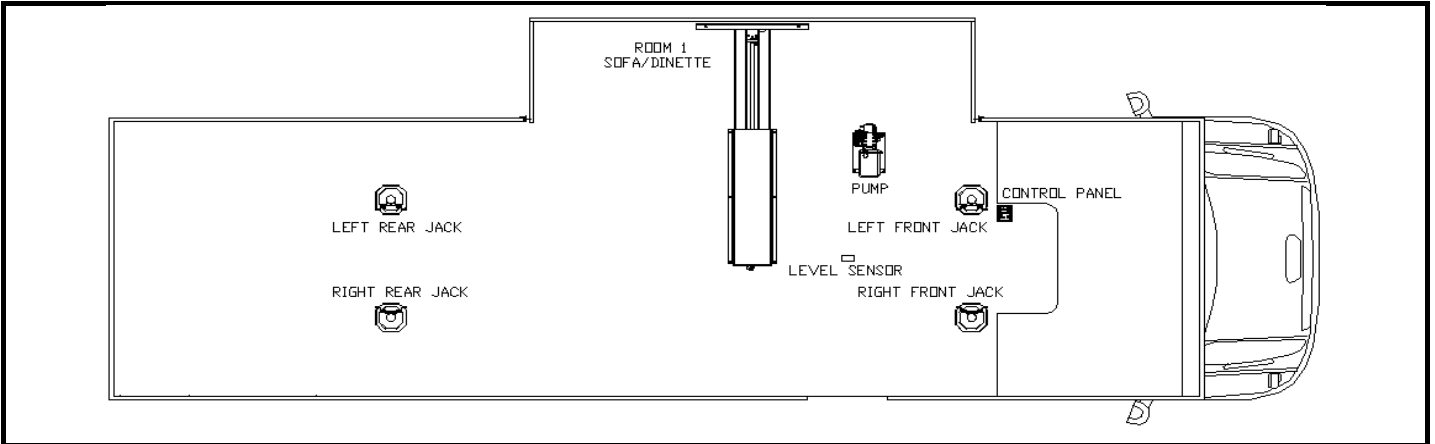

Notes:

1) Jacks mount 2nd hole from top to top mounting plate hole.

Item, Length	Description / Location	Qty	Color	Vendor PN	
Kit	(Items listed below)	1		8264	Measuring from back of cab floor, this is the end location of the hydraulic hoses where they attach to the slide mechanism.
Pump	5-Function, 1 Room, Jacks	1		7242	
Jack	12,000 lbs, 16" Stroke	4		7214	
Control Panel	Located to the right of the drivers seat	1		2057	
Level Sensor	Attached to bottom of structure	1		7196	
Flow Divider	Mounted inside pump compartment	N/A		N/A	
Hose, 84	Pump to Jack, Left Front	2	Brown	7287	
Hose, 223	Pump to Jack, Left Rear	2	Orange	7249	
Hose, 100	Pump to Jack, Right Front	2	White	7288	
Hose, 223	Pump to Jack, Right Rear	2	Yellow	7289	
Hose, N/A	Pump to Flow Divider	N/A	TBD	N/A	N/A
Hose, N/A	Flow divider to front slide, Room 1	N/A	TBD	N/A	N/A
Hose, N/A	Flow divider to rear slide, Room 1	N/A	TBD	N/A	N/A
Hose, 84	Pump to Room 1	2	Green	7254	80 / Drivers Side
Hose, N/A	Pump to Room 2	N/A	Purple	N/A	N/A
Hose, N/A	Pump to Room 3	N/A	Gray	N/A	N/A
Hose, N/A	Pump to Room 4	N/A	Red	N/A	N/A
Hose, N/A	Pump to Generator Slide	N/A	TBD	N/A	N/A
Travel Clamp	Two per Slide	N/A		HWH	N/A
Options					
Revisions					
	Description		By		Date
1	Made Jack, Control Panel, Level Sensor & hoses standard		JB		11/17/2005

**33K KODIAK (19.5) TIRES
EQUALIZER JACKS (FULLY AUTOMATIC)
OPTIONAL ON THIS UNIT**

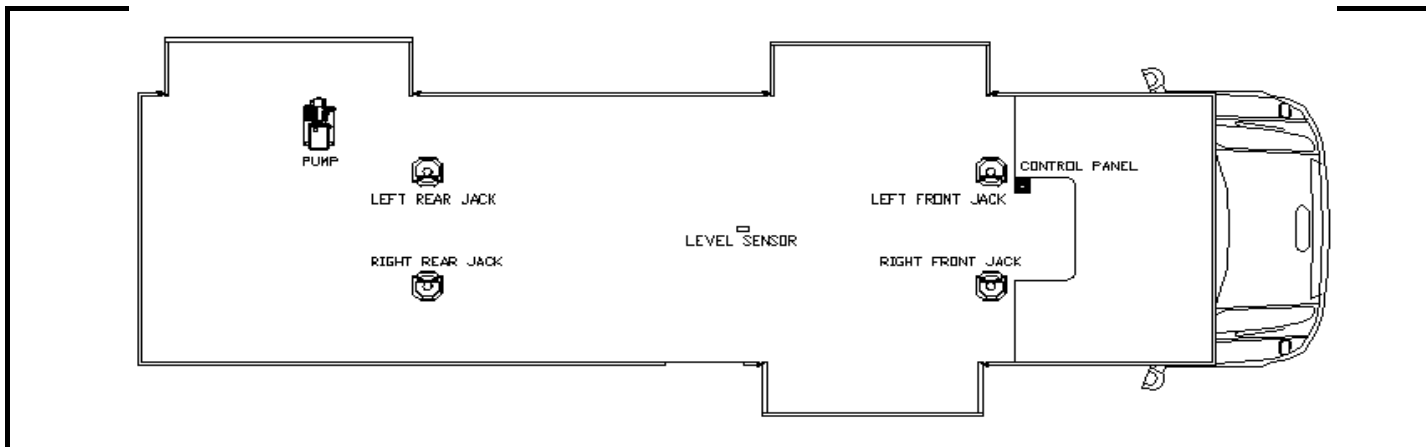

Notes:

1) Jacks mount 2nd hole from top to top mounting plate hole.

Item, Length	Description / Location	Qty	Color	Vendor PN	Measuring from back of cab floor, this is the end location of the hydraulic hoses where they attach to the slide mechanism.
Flow Divider	Mounted inside pump compartment	N/A		N/A	
Hose, N/A	Pump to Flow Divider	N/A	TBD	N/A	N/A
Hose, N/A	Flow divider to front slide, Room 1	N/A	TBD	N/A	N/A
Hose, N/A	Flow divider to rear slide, Room 1	N/A	TBD	N/A	N/A
Hose, N/A	Pump to Room 1	N/A	Green	N/A	N/A
Hose, N/A	Pump to Room 2	N/A	Purple	N/A	N/A
Hose, N/A	Pump to Room 3	N/A	Gray	N/A	N/A
Hose, N/A	Pump to Room 4	N/A	Red	N/A	N/A
Hose, N/A	Pump to Generator Slide	N/A	TBD	N/A	N/A
Travel Clamp	Two per Slide	N/A	N/A	HWH	N/A
Options					
Kit	(Items listed below)	1		8274	
Pump	4-Function, Jacks	1		7239	
Jack	12,000 lbs, 16" Stroke	4		7214	
Control Panel	Located to the right of the drivers seat	1		2057	
Level Sensor	Attached to bottom of structure	1		7196	
Hose, 300	Pump to Jack, Left Front	2	Brown	7247	
Hose, 100	Pump to Jack, Left Rear	2	Orange	7248	
Hose, 300	Pump to Jack, Right Front	2	White	7304	
Hose, 126	Pump to Jack, Right Rear	2	Yellow	7305	
Revisions					

**34G KODIAK (19.5) TIRES
EQUALIZER JACKS (FULLY AUTOMATIC)
OPTIONAL ON THIS UNIT**

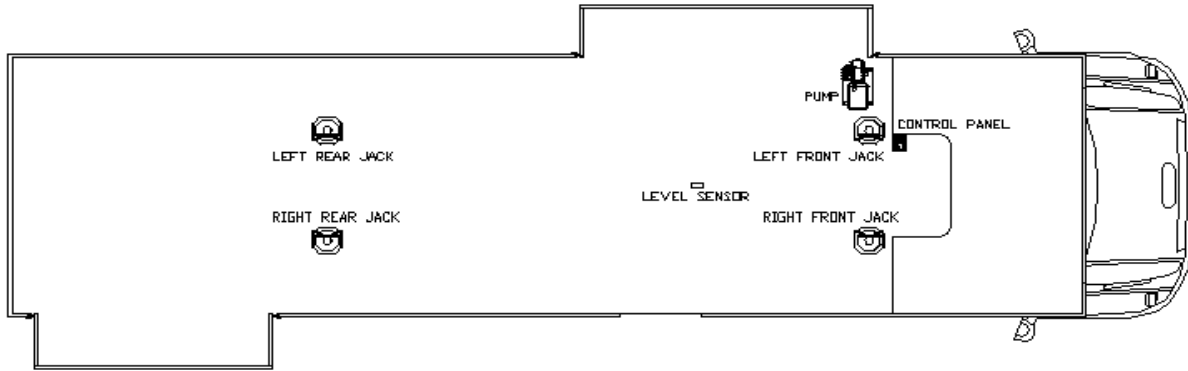

Notes:

1) Jacks mount 2nd hole from top to top mounting plate hole.

Item, Length	Description / Location	Qty	Color	Vendor PN	Measuring from back of cab floor, this is the end location of the hydraulic hoses where they attach to the slide mechanism.
Flow Divider	Mounted inside pump compartment	N/A		N/A	
Hose, N/A	Pump to Flow Divider	N/A	TBD	N/A	N/A
Hose, N/A	Flow divider to front slide, Room 1	N/A	TBD	N/A	N/A
Hose, N/A	Flow divider to rear slide, Room 1	N/A	TBD	N/A	N/A
Hose, N/A	Pump to Room 1	N/A	Green	N/A	N/A
Hose, N/A	Pump to Room 2	N/A	Purple	N/A	N/A
Hose, N/A	Pump to Room 3	N/A	Gray	N/A	N/A
Hose, N/A	Pump to Room 4	N/A	Red	N/A	N/A
Hose, N/A	Pump to Generator Slide	N/A	TBD	N/A	N/A
Travel Clamp	Two per Slide	N/A		HWH	N/A
Options					
Kit	(Items listed below)	1		8275	
Pump	4-Function, Jacks	1		7239	
Jack	12,000 lbs, 16" Stroke	4		7214	
Control Panel	Located to the right of the drivers seat	1		2057	
Level Sensor	Attached to bottom of structure	1		7196	
Hose, 84	Pump to Jack, Left Front	2	Brown	7287	
Hose, 223	Pump to Jack, Left Rear	2	Orange	7249	
Hose, 100	Pump to Jack, Right Front	2	White	7288	
Hose, 269	Pump to Jack, Right Rear	2	Yellow	7252	
Revisions					

**35B KODIAK (19.5) TIRES
EQUALIZER JACKS (FULLY AUTOMATIC)
OPTIONAL ON THIS UNIT**

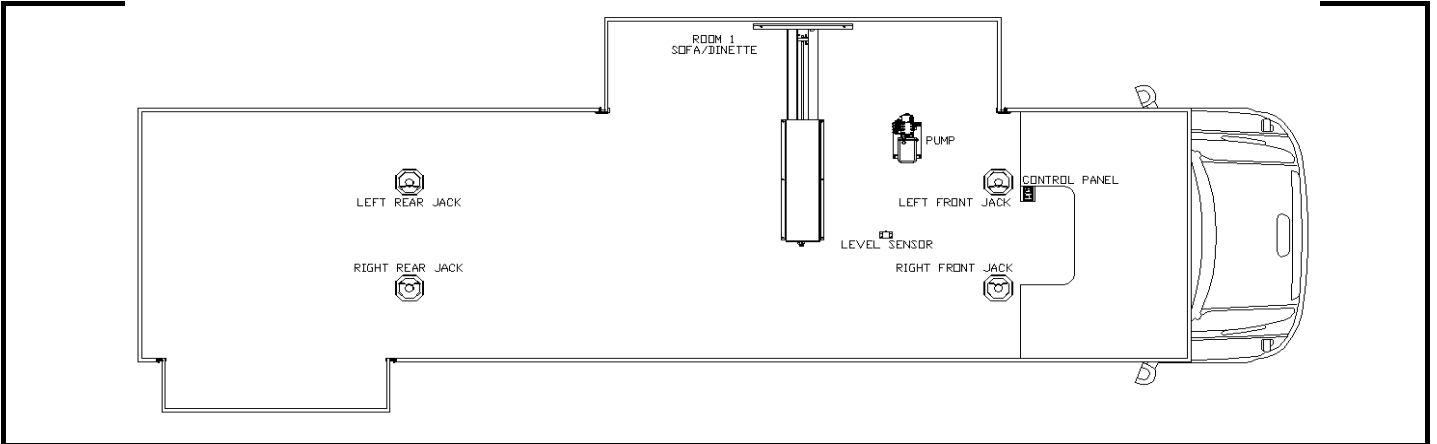

Notes:

1) Jacks mount 2nd hole from top to top mounting plate hole.

Item, Length	Description / Location	Qty	Color	Vendor PN	
Kit	(Items listed below)	1		8264	Measuring from back of cab floor, this is the end location of the hydraulic hoses where they attach to the slide mechanism.
Pump	5-Function, 1 Room, Jacks	1		7242	
Jack	12,000 lbs, 16" Stroke	4		7214	
Control Panel	Located to the right of the drivers seat	1		2057	
Level Sensor	Attached to bottom of structure	1		7196	
Flow Divider	Mounted inside pump compartment	N/A		N/A	
Hose, 84	Pump to Jack, Left Front	2	Brown	7287	
Hose, 240	Pump to Jack, Left Rear	2	Orange	7295	
Hose, 100	Pump to Jack, Right Front	2	White	7288	
Hose, 269	Pump to Jack, Right Rear	2	Yellow	7252	
Hose, N/A	Pump to Flow Divider	N/A	TBD	N/A	N/A
Hose, N/A	Flow divider to front slide, Room 1	N/A	TBD	N/A	N/A
Hose, N/A	Flow divider to rear slide, Room 1	N/A	TBD	N/A	N/A
Hose, 84	Pump to Room 1	2	Green	7254	80 / Drivers Side
Hose, N/A	Pump to Room 2	N/A	Purple	N/A	N/A
Hose, N/A	Pump to Room 3	N/A	Gray	N/A	N/A
Hose, N/A	Pump to Room 4	N/A	Red	N/A	N/A
Hose, N/A	Pump to Generator Slide	N/A	TBD	N/A	N/A
Travel Clamp	Two per Slide	N/A		HWH	N/A

Options

Revisions	Description	By	Date

**32R WINDSPORT (19.5) TIRES
EQUALIZER JACKS (FULLY AUTOMATIC)
STANDARD ON THIS UNIT**

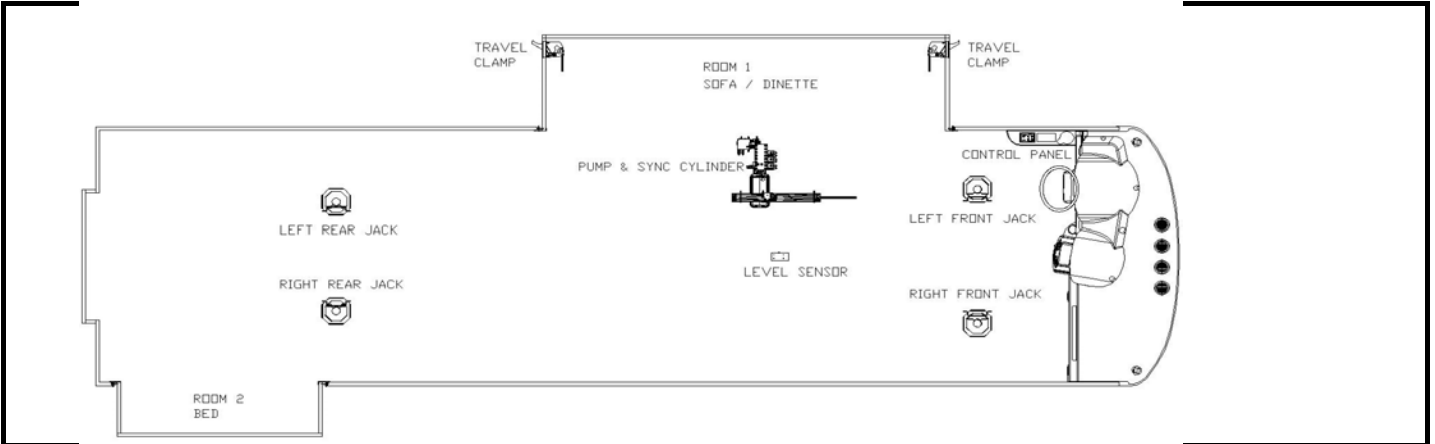

Notes:

- 1) Jacks mount in two different locations on bracket depending on tire size of chassis.
 - a) 19.5 Tires: Top hole in jack to top hole in bracket. Use 4 bolts in welded area of bracket.
 - b) 22.5 Tires: Top hole in jack to second hole in bracket. Use 6 bolts, 4 in welded area of bracket & 2 below welded area.

Item, Length	Description / Location	Qty	Color	Vendor PN		
Kit	(Items listed below)	1		8283	Measuring from inside of firewall, this is the end location of the hydraulic hoses where they attach to the slide mechanism.	
Pump	6-Function, 2 Rooms & Jacks	1		7243		
Jack	12,000 lbs, 16" Stroke	4		7214		
Control Panel	Located to the left of the drivers seat	1		2057		
Level Sensor	Attached to bottom of structure	1		7196		
Sync Cylinder	Mounted behind pump compartment	1		7351		
Hose, 140	Pump to Jack, Left Front	1	Brown	7294		
Hose, 240	Pump to Jack, Left Rear	1	Orange	7295		
Hose, 180	Pump to Jack, Right Front	1	White	7296		
Hose, 280	Pump to Jack, Right Rear	1	Yellow	7297		
Hose, 32	Pump to sync cylinder	2	Green	7298		Inside pump compartment
Hose w/90, 110	Sync cylinder to front slide, Room 1	2	Green	2392		95 / Drivers Side
Hose w/90, 110	Sync cylinder to rear slide, Room 1	2	Green	2392		166 / Drivers Side
Hose, N/A	Pump to Room 1	N/A	Green	N/A		N/A
Hose, 364	Pump to Room 2	1	Purple	7300		310 / Passenger Side
Hose, N/A	Pump to Room 3	N/A	Gray	N/A		N/A
Hose, N/A	Pump to Room 4	N/A	Red	N/A		N/A
Hose, N/A	Pump to Generator Slide	N/A	N/A	N/A		N/A
Travel Clamp	Two per Slide (except bed slide)	2		HWH		N/A

Options

Item, Length	Description / Location	Qty	Color	Vendor PN	

Revisions

Rev	Description
1	Flow divider replaces sync cylinder (addendum to original ECN 3706)

**34A WINDSPORT (19.5) TIRES
EQUALIZER JACKS (FULLY AUTOMATIC)
STANDARD ON THIS UNIT**

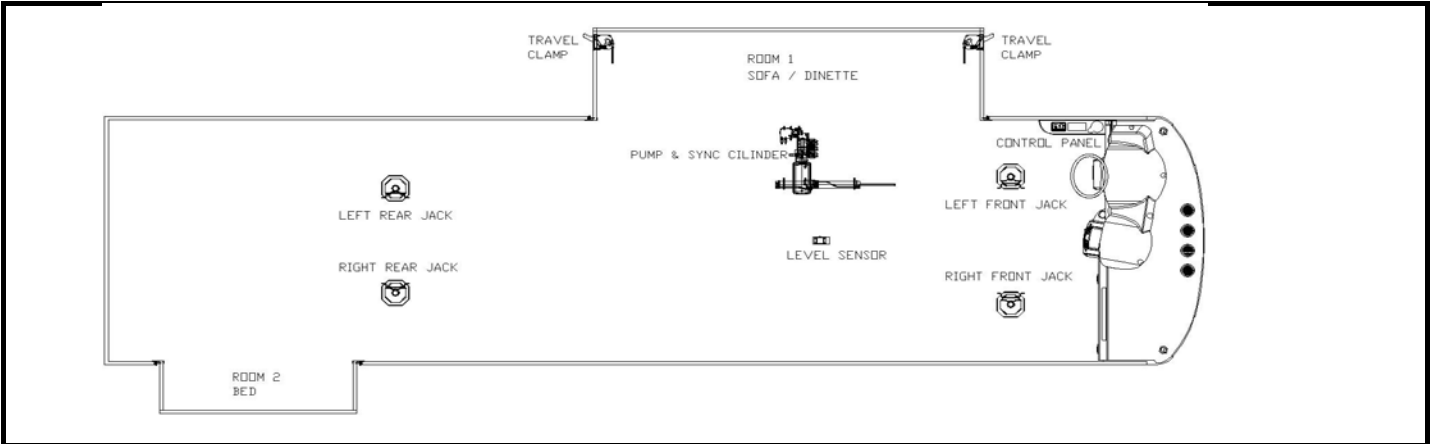

Notes:

1) Jacks mount in two different locations on bracket depending on tire size of chassis.

a) 19.5 Tires: Top hole in jack to top hole in bracket. Use 4 bolts in welded area of bracket.

b) 22.5 Tires: Top hole in jack to second hole in bracket. Use 6 bolts, 4 in welded area of bracket & 2 below welded area.

Item, Length	Description / Location	Qty	Color	Vendor PN		
Kit	(Items listed below)	1		8284		
Pump	6-Function, 2 Rooms & Jacks	1		7243		
Jack	12,000 lbs, 16" Stroke	4		7214		
Control Panel	Located to the left of the drivers seat	1		2057		
Level Sensor	Attached to bottom of structure	1		7196		
Sync Cylinder	Mounted behind pump compartment	1		7351		
Hose, 140	Pump to Jack, Left Front	1	Brown	7294	Measuring from inside of firewall, this is the end location of the hydraulic hoses where they attach to the slide mechanism.	
Hose, 240	Pump to Jack, Left Rear	1	Orange	7295		
Hose, 180	Pump to Jack, Right Front	1	White	7296		
Hose, 280	Pump to Jack, Right Rear	1	Yellow	7297		
Hose, 32	Pump to sync cylinder	2	Green	7298		Inside pump compartment
Hose w/90, 110	Sync cylinder to front slide, Room 1	2	Green	2392		95 / Drivers Side
Hose w/90, 110	Sync cylinder to rear slide, Room 1	2	Green	2392		166 / Drivers Side
Hose, N/A	Pump to Room 1	N/A	Green	N/A		N/A
Hose, 364	Pump to Room 2	1	Purple	7300		301 / Passenger Side
Hose, N/A	Pump to Room 3	N/A	Gray	N/A		N/A
Hose, N/A	Pump to Room 4	N/A	Red	N/A	N/A	
Hose, N/A	Pump to Generator Slide	N/A	N/A	N/A	N/A	
Travel Clamp	Two per Slide (except bed slide)	2		HWH	N/A	

Options

Revisions

1	Flow divider replaces sync cylinder (addendum to original ECN 3706)

**34N WINDSPORT (19.5) TIRES
34N MAGELLAN (22.5) TIRES
EQUALIZER JACKS (FULLY AUTOMATIC)
STANDARD ON THIS UNIT**

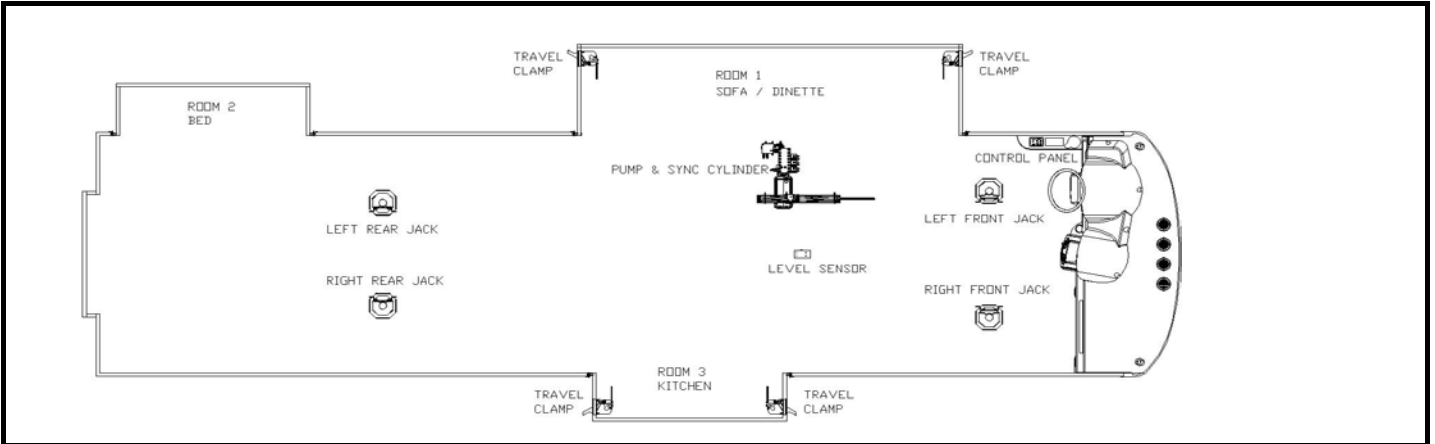

Notes:

1) Jacks mount in two different locations on bracket depending on tire size of chassis.

a) 19.5 Tires: Top hole in jack to top hole in bracket. Use 4 bolts in welded area of bracket.

b) 22.5 Tires: Top hole in jack to second hole in bracket. Use 6 bolts, 4 in welded area of bracket & 2 below welded area.

Item, Length	Description / Location	Qty	Color	Vendor PN		
Kit	(Items listed below)	1		8285		
Pump	7-Function, 3 Rooms & Jacks	1		7301		
Jack	12,000 lbs, 16" Stroke	4		7214		
Control Panel	Located to the left of the drivers seat	1		2057		
Level Sensor	Attached to bottom of structure	1		7196		
Sync Cylinder	Mounted behind pump compartment	1		7351		
Hose, 140	Pump to Jack, Left Front	1	Brown	7294	Measuring from inside of firewall, this is the end location of the hydraulic hoses where they attach to the slide mechanism.	
Hose, 240	Pump to Jack, Left Rear	1	Orange	7295		
Hose, 180	Pump to Jack, Right Front	1	White	7296		
Hose, 280	Pump to Jack, Right Rear	1	Yellow	7297		
Hose, 32	Pump to sync cylinder	2	Green	7298		Inside pump compartment
Hose w/90, 110	Sync cylinder to front slide, Room 1	2	Green	2392		95 / Drivers Side
Hose w/90, 110	Sync cylinder to rear slide, Room 1	2	Green	2392		166 / Drivers Side
Hose, N/A	Pump to Room 1	N/A	Green	N/A		N/A
Hose, 364	Pump to Room 2	1	Purple	7300		323 / Drivers Side
Hose w90, 110	Pump to Room 3	1	Gray	7299		160 / Passenger Side
Hose, N/A	Pump to Room 4	N/A	Red	N/A	N/A	
Hose, N/A	Pump to Generator Slide	N/A	N/A	N/A	N/A	
Travel Clamp	Two per Slide (except bed slide)	4		HWH	N/A	

Options

Item, Length	Description / Location	Qty	Color	Vendor PN	

Revisions

1	Flow divider replaces sync cylinder, add 90 fitting to "Pump to Room 3" (addendum to original ECN 3706)

**35W WINDSPORT (19.5) TIRES
EQUALIZER JACKS (FULLY AUTOMATIC)
STANDARD ON THIS UNIT**

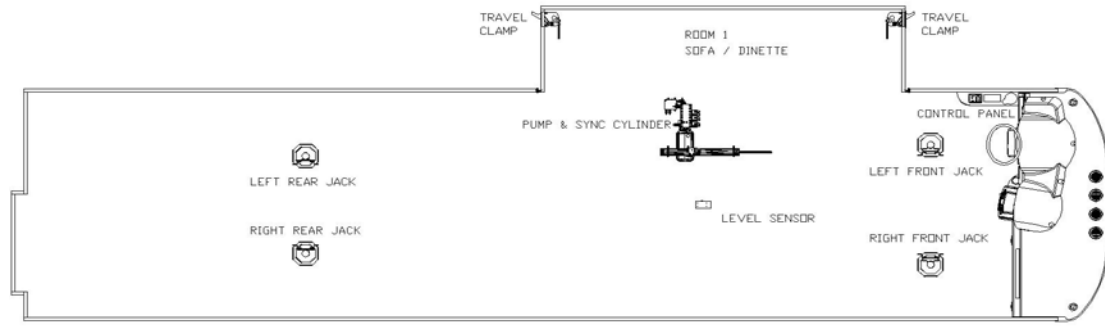

Notes:

1) Jacks mount in two different locations on bracket depending on tire size of chassis.

a) 19.5 Tires: Top hole in jack to top hole in bracket. Use 4 bolts in welded area of bracket.

b) 22.5 Tires: Top hole in jack to second hole in bracket. Use 6 bolts, 4 in welded area of bracket & 2 below welded area.

Item, Length	Description / Location	Qty	Color	Vendor PN		
Kit	(Items listed below)	1		8286		
Pump	5-Function, 1 Room & Jacks	1		7242		
Jack	12,000 lbs, 16" Stroke	4		7214		
Control Panel	Located to the left of the drivers seat	1		2057		
Level Sensor	Attached to bottom of structure	1		7196		
Sync Cylinder	Mounted behind pump compartment	1		7351		
Hose, 160	Pump to Jack, Left Front	1	Brown	7320	Measuring from inside of firewall, this is the end location of the hydraulic hoses where they attach to the slide mechanism.	
Hose, 240	Pump to Jack, Left Rear	1	Orange	7295		
Hose, 200	Pump to Jack, Right Front	1	White	7321		
Hose, 280	Pump to Jack, Right Rear	1	Yellow	7297		
Hose, 32	Pump to sync cylinder	2	Green	7298		Inside pump compartment
Hose w/90, 110	Sync cylinder to front slide, Room 1	2	Green	2392		95 / Drivers Side
Hose w/90, 110	Sync cylinder to rear slide, Room 1	2	Green	2392		166 / Drivers Side
Hose, N/A	Pump to Room 1	N/A	Green	N/A		N/A
Hose, N/A	Pump to Room 2	N/A	Purple	N/A		N/A
Hose, N/A	Pump to Room 3	N/A	Gray	N/A		N/A
Hose, N/A	Pump to Room 4	N/A	Red	N/A	N/A	
Hose, N/A	Pump to Generator Slide	N/A	N/A	N/A	N/A	
Travel Clamp	Two per Slide (except bed slide)	2		HWH	N/A	

Options

Revisions

1	Omit hoses erroneously entered for room 2.
2	Flow divider replaces sync cylinder (addendum to original ECN 3706)

**36A WINDSPORT (19.5) TIRES
36A MAGELLAN (22.5) TIRES
EQUALIZER JACKS (FULLY AUTOMATIC)
STANDARD ON THIS UNIT**

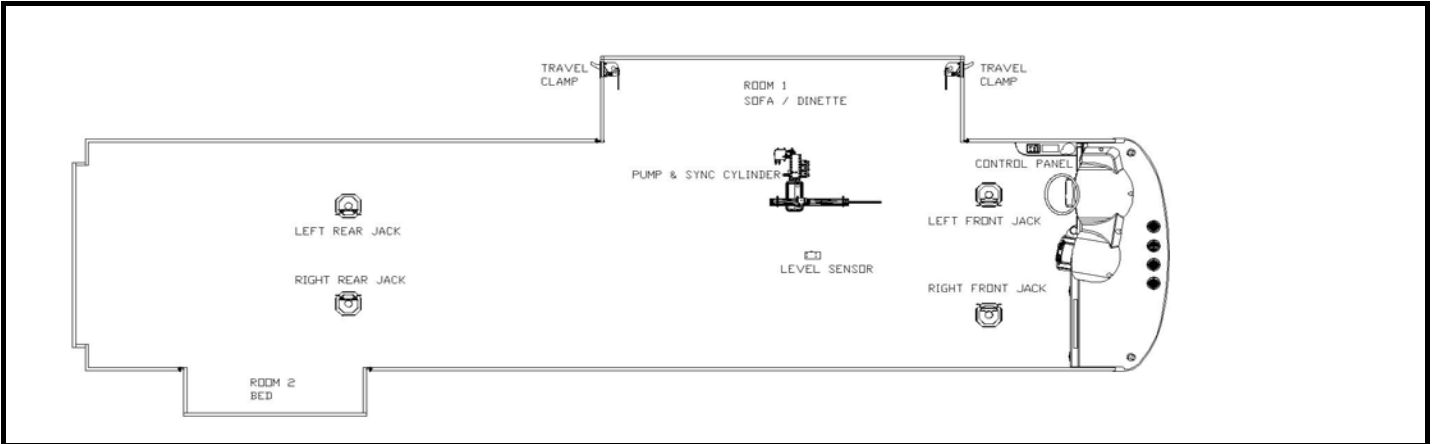

Notes:

1) Jacks mount in two different locations on bracket depending on tire size of chassis.

a) 19.5 Tires: Top hole in jack to top hole in bracket. Use 4 bolts in welded area of bracket.

b) 22.5 Tires: Top hole in jack to second hole in bracket. Use 6 bolts, 4 in welded area of bracket & 2 below welded area.

Item, Length	Description / Location	Qty	Color	Vendor PN		
Kit	(Items listed below)	1		8287		
Pump	6-Function, 2 Rooms & Jacks	1		7243		
Jack	12,000 lbs, 16" Stroke	4		7214		
Control Panel	Located to the left of the drivers seat	1		2057		
Level Sensor	Attached to bottom of structure	1		7196		
Sync Cylinder	Mounted behind pump compartment	1		7351		
Hose, 140	Pump to Jack, Left Front	1	Brown	7294	Measuring from inside of firewall, this is the end location of the hydraulic hoses where they attach to the slide mechanism.	
Hose, 264	Pump to Jack, Left Rear	1	Orange	7322		
Hose, 180	Pump to Jack, Right Front	1	White	7296		
Hose, 300	Pump to Jack, Right Rear	1	Yellow	7323		
Hose, 32	Pump to sync cylinder	2	Green	7298		Inside pump compartment
Hose w/90, 110	Sync cylinder to front slide, Room 1	2	Green	2392		95 / Drivers Side
Hose w/90, 110	Sync cylinder to rear slide, Room 1	2	Green	2392		166 / Drivers Side
Hose, N/A	Pump to Room 1	N/A	Green	N/A		N/A
Hose, 364	Pump to Room 2	1	Purple	7300		301 / Passenger Side
Hose, N/A	Pump to Room 3	N/A	Gray	N/A		N/A
Hose, N/A	Pump to Room 4	N/A	Red	N/A	N/A	
Hose, N/A	Pump to Generator Slide	N/A	N/A	N/A	N/A	
Travel Clamp	Two per Slide (except bed slide)	2		HWH	N/A	

Options

Item, Length	Description / Location	Qty	Color	Vendor PN	

Revisions

1	Flow divider replaces sync cylinder (addendum to original ECN 3706)

**36E WINDSPORT (19.5) TIRES
36E MAGELLAN (22.5) TIRES
EQUALIZER JACKS (FULLY AUTOMATIC)
STANDARD ON THIS UNIT**

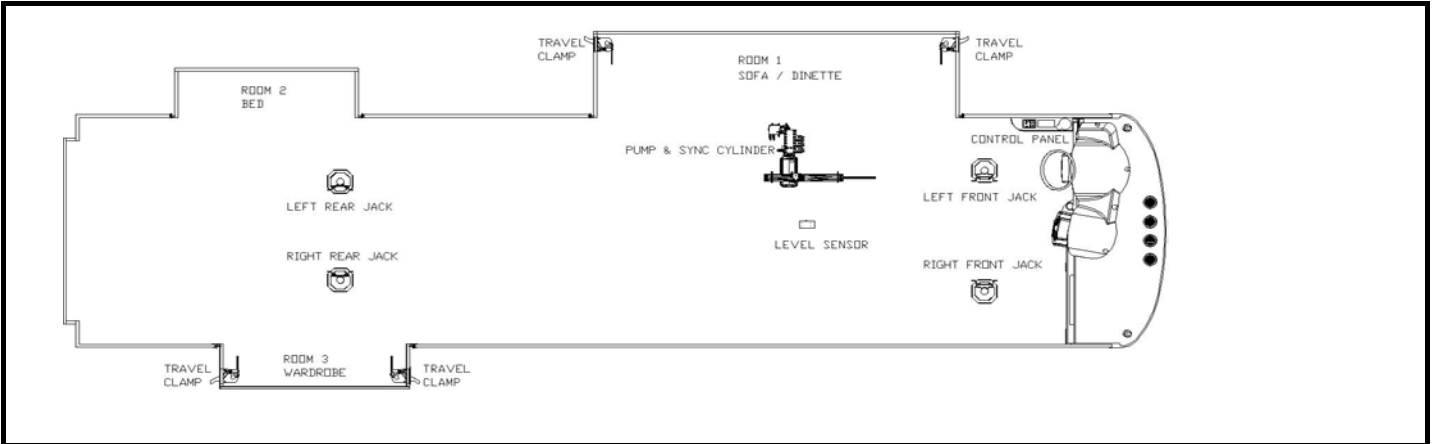

Notes:

- 1) Jacks mount in two different locations on bracket depending on tire size of chassis.
 - a) 19.5 Tires: Top hole in jack to top hole in bracket. Use 4 bolts in welded area of bracket.
 - b) 22.5 Tires: Top hole in jack to second hole in bracket. Use 6 bolts, 4 in welded area of bracket & 2 below welded area.

Item, Length	Description / Location	Qty	Color	Vendor PN		
Kit	(Items listed below)	1		8288	Measuring from inside of firewall, this is the end location of the hydraulic hoses where they attach to the slide mechanism.	
Pump	7-Function, 3 Rooms & Jacks	1		7301		
Jack	12,000 lbs, 16" Stroke	4		7214		
Control Panel	Located to the left of the drivers seat	1		2057		
Level Sensor	Attached to bottom of structure	1		7196		
Sync Cylinder	Mounted behind pump compartment	1		7351		
Hose, 140	Pump to Jack, Left Front	1	Brown	7294		
Hose, 264	Pump to Jack, Left Rear	1	Orange	7322		
Hose, 180	Pump to Jack, Right Front	1	White	7296		
Hose, 300	Pump to Jack, Right Rear	1	Yellow	7323		
Hose, 32	Pump to sync cylinder	2	Green	7298		Inside pump compartment
Hose w/90, 110	Sync cylinder to front slide, Room 1	2	Green	2392		95 / Drivers Side
Hose w/90, 110	Sync cylinder to rear slide, Room 1	2	Green	2392		166 / Drivers Side
Hose, N/A	Pump to Room 1	N/A	Green	N/A		N/A
Hose, 364	Pump to Room 2	1	Purple	7300		319 / Drivers Side
Hose w/90, 364	Pump to Room 3	1	Gray	7324	319 / Passenger Side	
Hose, N/A	Pump to Room 4	N/A	Red	N/A	N/A	
Hose, N/A	Pump to Generator Slide	N/A	N/A	N/A	N/A	
Travel Clamp	Two per Slide (except bed slide)	4		HWH	N/A	

Options

Revisions

1	Flow divider replaces sync cylinder, add 90 fitting to "Pump to Room 3" (addendum to original ECN 3706)

**36K WINDSPORT (19.5) TIRES
36K MAGELLAN (22.5) TIRES
EQUALIZER JACKS (FULLY AUTOMATIC)
STANDARD ON THIS UNIT**

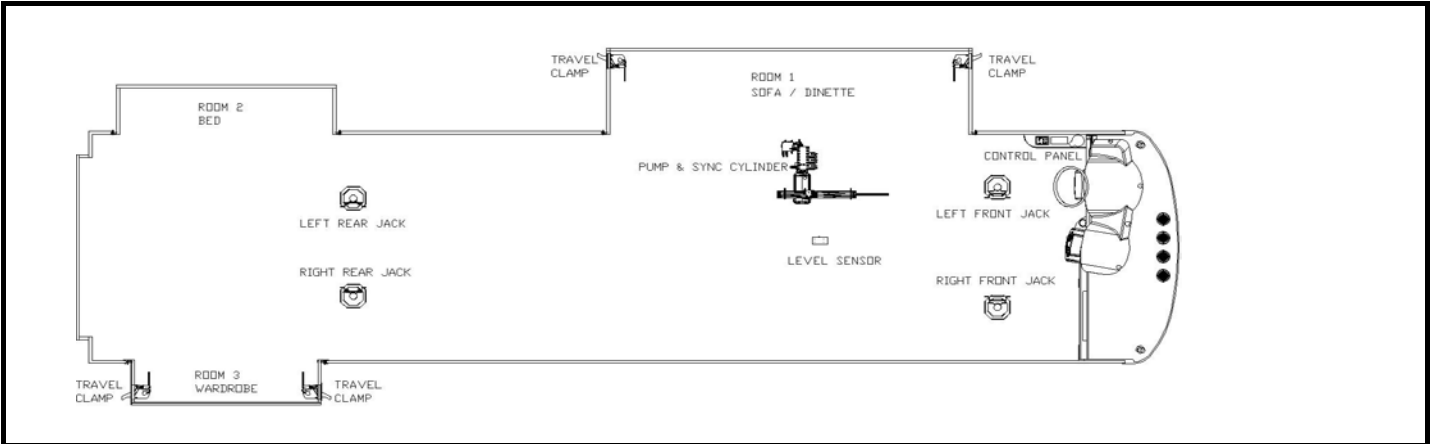

Notes:

- 1) Jacks mount in two different locations on bracket depending on tire size of chassis.
 - a) 19.5 Tires: Top hole in jack to top hole in bracket. Use 4 bolts in welded area of bracket.
 - b) 22.5 Tires: Top hole in jack to second hole in bracket. Use 6 bolts, 4 in welded area of bracket & 2 below welded area.

Item, Length	Description / Location	Qty	Color	Vendor PN		
Kit	(Items listed below)	1		8289		
Pump	7-Function, 3 Rooms & Jacks	1		7301		
Jack	12,000 lbs, 16" Stroke	4		7214		
Control Panel	Located to the left of the drivers seat	1		2057		
Level Sensor	Attached to bottom of structure	1		7196		
Sync Cylinder	Mounted behind pump compartment	1		7351		
Hose, 140	Pump to Jack, Left Front	1	Brown	7294	Measuring from inside of firewall, this is the end location of the hydraulic hoses where they attach to the slide mechanism.	
Hose, 264	Pump to Jack, Left Rear	1	Orange	7322		
Hose, 180	Pump to Jack, Right Front	1	White	7296		
Hose, 300	Pump to Jack, Right Rear	1	Yellow	7323		
Hose, 32	Pump to sync cylinder	2	Green	7298		Inside pump compartment
Hose w/90, 110	Sync cylinder to front slide, Room 1	2	Green	2392		95 / Drivers Side
Hose w/90, 110	Sync cylinder to rear slide, Room 1	2	Green	2392		166 / Drivers Side
Hose, N/A	Pump to Room 1	N/A	Green	N/A		N/A
Hose, 364	Pump to Room 2	1	Purple	7300		340 / Drivers Side
Hose w/90, 364	Pump to Room 3	1	Gray	7324		323 / Passenger Side
Hose, N/A	Pump to Room 4	N/A	Red	N/A	N/A	
Hose, N/A	Pump to Generator Slide	N/A	N/A	N/A	N/A	
Travel Clamp	Two per Slide (except bed slide)	4		HWH	N/A	

Options					

Revisions					
1	Flow divider replaces sync cylinder, add 90 fitting to "Pump to Room 3" (addendum to original ECN 3706)				

**36Z WINDSPORT (19.5) TIRES
36Z MAGELLAN (22.5) TIRES
EQUALIZER JACKS (FULLY AUTOMATIC)
STANDARD ON THIS UNIT**

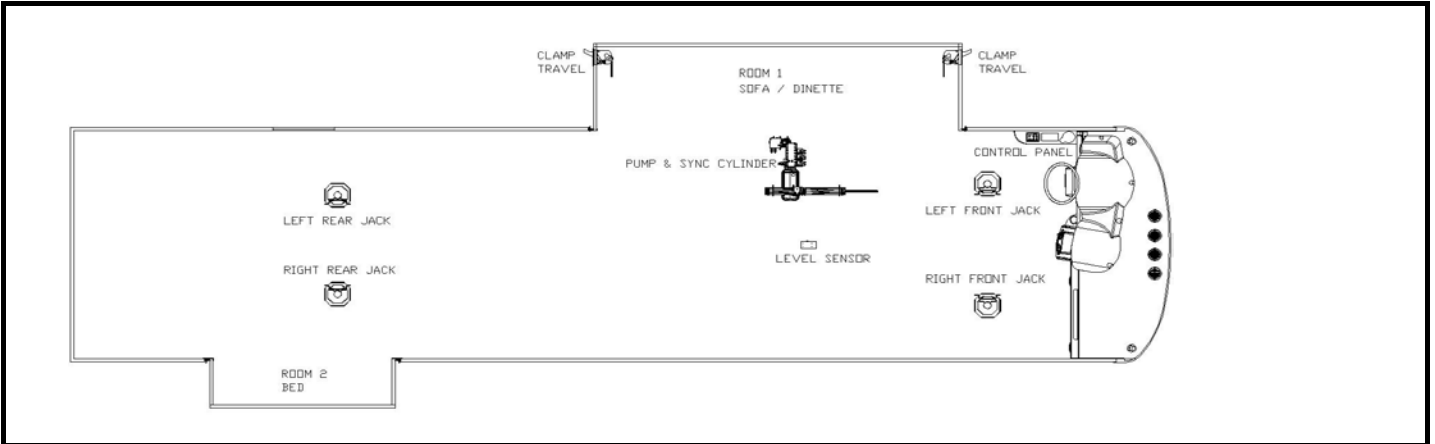

Notes:

- 1) Jacks mount in two different locations on bracket depending on tire size of chassis.
 - a) 19.5 Tires: Top hole in jack to top hole in bracket. Use 4 bolts in welded area of bracket.
 - b) 22.5 Tires: Top hole in jack to second hole in bracket. Use 6 bolts, 4 in welded area of bracket & 2 below welded area.

Item, Length	Description / Location	Qty	Color	Vendor PN		
Kit	(Items listed below)	1		8290	Measuring from inside of firewall, this is the end location of the hydraulic hoses where they attach to the slide mechanism.	
Pump	6-Function, 2 Rooms & Jacks	1		7243		
Jack	12,000 lbs, 16" Stroke	4		7214		
Control Panel	Located to the left of the drivers seat	1		2057		
Level Sensor	Attached to bottom of structure	1		7196		
Sync Cylinder	Mounted behind pump compartment	1		7351		
Hose, 140	Pump to Jack, Left Front	1	Brown	7294		
Hose, 264	Pump to Jack, Left Rear	1	Orange	7322		
Hose, 180	Pump to Jack, Right Front	1	White	7296		
Hose, 300	Pump to Jack, Right Rear	1	Yellow	7323		
Hose, 32	Pump to sync cylinder	2	Green	7298		Inside pump compartment
Hose w/90, 110	Sync cylinder to front slide, Room 1	2	Green	2392		95 / Drivers Side
Hose w/90, 110	Sync cylinder to rear slide, Room 1	2	Green	2392		166 / Drivers Side
Hose, N/A	Pump to Room 1	N/A	Green	N/A		N/A
Hose, 364	Pump to Room 2	1	Purple	7300		319 / Passenger Side
Hose, N/A	Pump to Room 3	N/A	Gray	N/A		N/A
Hose, N/A	Pump to Room 4	N/A	Red	N/A	N/A	
Hose, N/A	Pump to Generator Slide	N/A	N/A	N/A	N/A	
Travel Clamp	Two per Slide (except bed slide)	2		HWH	N/A	

Options

Item, Length	Description / Location	Qty	Color	Vendor PN	

Revisions

1	Flow divider replaces sync cylinder (addendum to original ECN 3706)

**38E MAGELLAN (22.5) TIRES
EQUALIZER JACKS (FULLY AUTOMATIC)
STANDARD ON THIS UNIT**

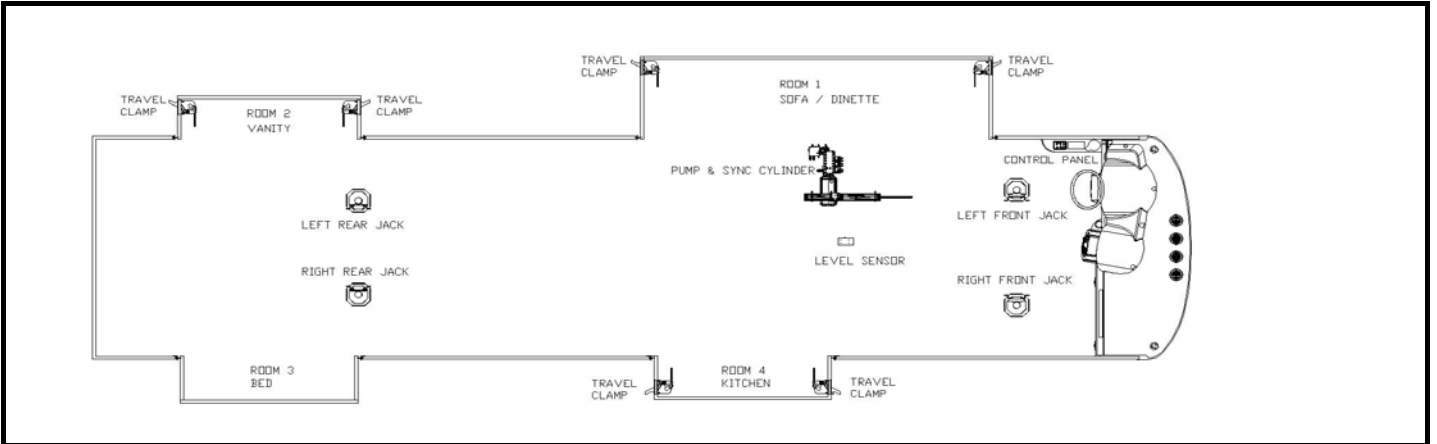

Notes:

- 1) Jacks mount in two different locations on bracket depending on tire size of chassis.
 - a) 19.5 Tires: Top hole in jack to top hole in bracket. Use 4 bolts in welded area of bracket.
 - b) 22.5 Tires: Top hole in jack to second hole in bracket. Use 6 bolts, 4 in welded area of bracket & 2 below welded area.

Item, Length	Description / Location	Qty	Color	Vendor PN		
Kit	(Items listed below)	1		8291	Measuring from inside of firewall, this is the end location of the hydraulic hoses where they attach to the slide mechanism.	
Pump	8-Function, 4 Rooms & Jacks	1		7302		
Jack	12,000 lbs, 16" Stroke	4		7214		
Control Panel	Located to the left of the drivers seat	1		2057		
Level Sensor	Attached to bottom of structure	1		7196		
Sync Cylinder	Mounted behind pump compartment	1		7351		
Hose, 140	Pump to Jack, Left Front	1	Brown	7294		
Hose, 282	Pump to Jack, Left Rear	1	Orange	7325		
Hose, 180	Pump to Jack, Right Front	1	White	7296		
Hose, 318	Pump to Jack, Right Rear	1	Yellow	7326		
Hose, 32	Pump to sync cylinder	2	Green	7298		Inside pump compartment
Hose w/90, 110	Sync cylinder to front slide, Room 1	2	Green	2392		95 / Drivers Side
Hose w/90, 110	Sync cylinder to rear slide, Room 1	2	Green	2392		166 / Drivers Side
Hose, N/A	Pump to Room 1	N/A	Green	N/A		N/A
Hose, 364	Pump to Room 2	1	Purple	7300		356 / Drivers Side
Hose, 396	Pump to Room 3	1	Gray	7327		344 / Passenger Side
Hose w/90, 110	Pump to Room 4	1	Red	7328	160 / Passenger Side	
Hose, N/A	Pump to Generator Slide	N/A	N/A	N/A	N/A	
Travel Clamp	Two per Slide (except bed slide)	6		HWH	N/A	

Options

Item, Length	Description / Location	Qty	Color	Vendor PN	

Revisions

Rev	Description
1	Flow divider replaces sync cylinder, add 90 fitting to "Pump to Room 4" (addendum to original ECN 3706)

**32R WINDSPORT (19.5) TIRES
EQUALIZER JACKS (FULLY AUTOMATIC)
STANDARD ON THIS UNIT**

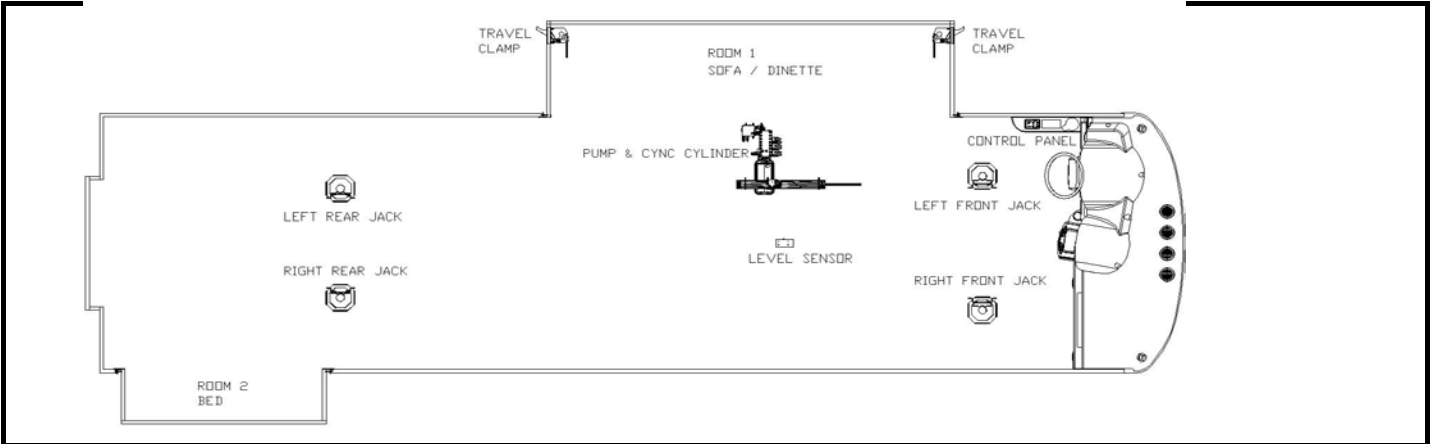

Notes:

1) Jacks mount in two different locations on bracket depending on tire size of chassis.

a) 19.5 Tires: Top hole in jack to top hole in bracket. Use 4 bolts in welded area of bracket.

b) 22.5 Tires: Top hole in jack to second hole in bracket. Use 6 bolts, 4 in welded area of bracket & 2 below welded area.

Item, Length	Description / Location	Qty	Color	Vendor PN		
Kit	(Items listed below)	1		8283		
Pump	6-Function, 2 Rooms & Jacks	1		7243		
Jack	12,000 lbs, 16" Stroke	4		7214		
Control Panel	Located to the left of the drivers seat	1		2057		
Level Sensor	Attached to bottom of structure	1		7196		
Sync Cylinder	Mounted behind pump compartment	1		7351		
Hose, 140	Pump to Jack, Left Front	1	Brown	7294	Measuring from inside of firewall, this is the end location of the hydraulic hoses where they attach to the slide mechanism.	
Hose, 240	Pump to Jack, Left Rear	1	Orange	7295		
Hose, 180	Pump to Jack, Right Front	1	White	7296		
Hose, 280	Pump to Jack, Right Rear	1	Yellow	7297		
Hose, 32	Pump to sync cylinder	2	Green	7298		Inside pump compartment
Hose, 110	Sync cylinder to front slide, Room 1	2	Green	2392		95 / Drivers Side
Hose, 110	Sync Cylinder to rear slide, Room 1	2	Green	2392		166 / Drivers Side
Hose, N/A	Pump to Room 1	N/A	Green	N/A		N/A
Hose, 364	Pump to Room 2	1	Purple	7300		310 / Passenger Side
Hose, N/A	Pump to Room 3	N/A	Gray	N/A		N/A
Hose, N/A	Pump to Room 4	N/A	Red	N/A	N/A	
Hose, N/A	Pump to Generator Slide	N/A		N/A	N/A	
Travel Clamp	Two per Slide (except bed slide)	2		HWH	N/A	

Options

Revisions

**34A WINDSPORT (19.5) TIRES
EQUALIZER JACKS (FULLY AUTOMATIC)
STANDARD ON THIS UNIT**

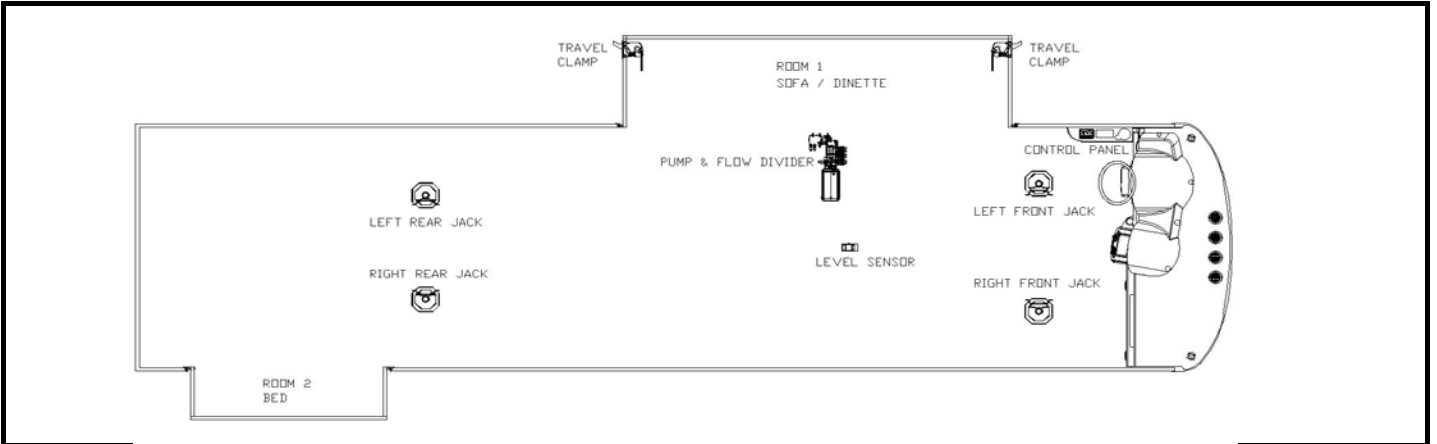

Notes:

- 1) Jacks mount in two different locations on bracket depending on tire size of chassis.
 - a) 19.5 Tires: Top hole in jack to top hole in bracket. Use 4 bolts in welded area of bracket.
 - b) 22.5 Tires: Top hole in jack to second hole in bracket. Use 6 bolts, 4 in welded area of bracket & 2 below welded area.

Item, Length	Description / Location	Qty	Color	Vendor PN		
Kit	(Items listed below)	1		8284	Measuring from inside of firewall, this is the end location of the hydraulic hoses where they attach to the slide mechanism.	
Pump	6-Function, 2 Rooms & Jacks	1		7243		
Jack	12,000 lbs, 16" Stroke	4		7214		
Control Panel	Located to the left of the drivers seat	1		2057		
Level Sensor	Attached to bottom of structure	1		7196		
Flow Divider	Mounted inside pump compartment	1		7316		
Hose, 140	Pump to Jack, Left Front	1	Brown	7294		
Hose, 240	Pump to Jack, Left Rear	1	Orange	7295		
Hose, 180	Pump to Jack, Right Front	1	White	7296		
Hose, 280	Pump to Jack, Right Rear	1	Yellow	7297		
Hose, 24	Pump to flow divider	1	Green	7310		Inside pump compartment
Hose w90, 140	Flow divider to front slide, Room 1	1	Green	7311		95 / Drivers Side
Hose w90, 140	Flow divider to rear slide, Room 1	1	Green	7311		166 / Drivers Side
Hose, N/A	Pump to Room 1	N/A	Green	N/A		N/A
Hose, 364	Pump to Room 2	1	Purple	7300	301 / Passenger Side	
Hose, N/A	Pump to Room 3	N/A	Gray	N/A	N/A	
Hose, N/A	Pump to Room 4	N/A	Red	N/A	N/A	
Hose, N/A	Pump to Generator Slide	N/A		N/A	N/A	
Travel Clamp	Two per Slide (except bed slide)	2		HWH	N/A	

Options

Revisions

**34N WINDSPORT (19.5) TIRES
34N MAGELLAN (22.5) TIRES
EQUALIZER JACKS (FULLY AUTOMATIC)
STANDARD ON THIS UNIT**

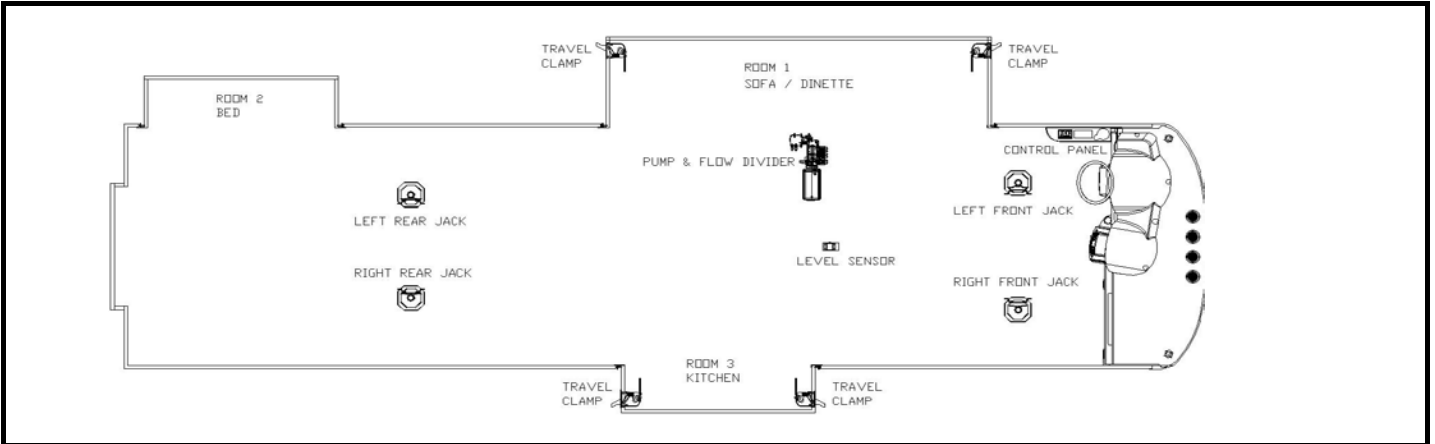

Notes:

- 1) Jacks mount in two different locations on bracket depending on tire size of chassis.
 - a) 19.5 Tires: Top hole in jack to top hole in bracket. Use 4 bolts in welded area of bracket.
 - b) 22.5 Tires: Top hole in jack to second hole in bracket. Use 6 bolts, 4 in welded area of bracket & 2 below welded area.

Item, Length	Description / Location	Qty	Color	Vendor PN	
Kit	(Items listed below)	1		8285	Measuring from inside of firewall, this is the end location of the hydraulic hoses where they attach to the slide mechanism.
Pump	7-Function, 3 Rooms & Jacks	1		7301	
Jack	12,000 lbs, 16" Stroke	4		7214	
Control Panel	Located to the left of the drivers seat	1		2057	
Level Sensor	Attached to bottom of structure	1		7196	
Flow Divider	Mounted inside pump compartment	1		7316	
Hose, 140	Pump to Jack, Left Front	1	Brown	7294	
Hose, 240	Pump to Jack, Left Rear	1	Orange	7295	
Hose, 180	Pump to Jack, Right Front	1	White	7296	
Hose, 280	Pump to Jack, Right Rear	1	Yellow	7297	
Hose, 24	Pump to flow divider	1	Green	7310	Inside pump compartment
Hose w90, 140	Flow divider to front slide, Room 1	1	Green	7311	95 / Drivers Side
Hose w90, 140	Flow divider to rear slide, Room 1	1	Green	7311	166 / Drivers Side
Hose, N/A	Pump to Room 1	N/A	Green	N/A	N/A
Hose, 364	Pump to Room 2	1	Purple	7300	323 / Drivers Side
Hose, 110	Pump to Room 3	1	Gray	7299	160 / Passenger Side
Hose, N/A	Pump to Room 4	N/A	Red	N/A	N/A
Hose, N/A	Pump to Generator Slide	N/A	N/A	N/A	N/A
Travel Clamp	Two per Slide (except bed slide)	4		HWH	N/A

Options

Revisions

**35W WINDSPORT (19.5) TIRES
EQUALIZER JACKS (FULLY AUTOMATIC)
STANDARD ON THIS UNIT**

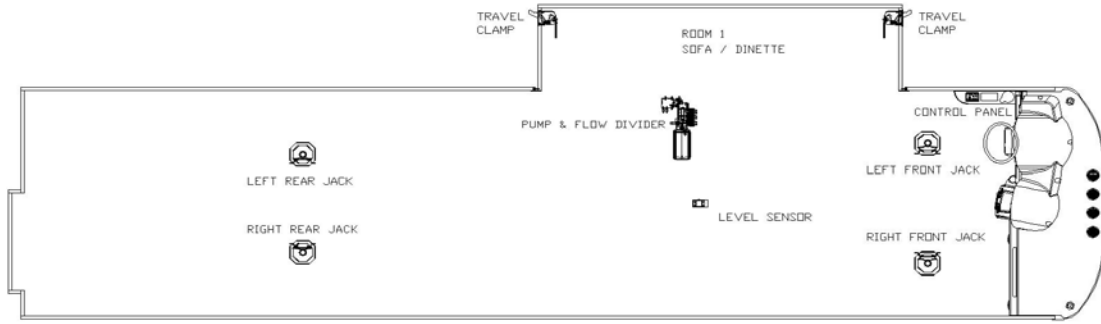

Notes:

1) Jacks mount in two different locations on bracket depending on tire size of chassis.

a) 19.5 Tires: Top hole in jack to top hole in bracket. Use 4 bolts in welded area of bracket.

b) 22.5 Tires: Top hole in jack to second hole in bracket. Use 6 bolts, 4 in welded area of bracket & 2 below welded area.

Item, Length	Description / Location	Qty	Color	Vendor PN		
Kit	(Items listed below)	1		8286	Measuring from inside of firewall, this is the end location of the hydraulic hoses where they attach to the slide mechanism.	
Pump	5-Function, 1 Room & Jacks	1		7242		
Jack	12,000 lbs, 16" Stroke	4		7214		
Control Panel	Located to the left of the drivers seat	1		2057		
Level Sensor	Attached to bottom of structure	1		7196		
Flow Divider	Mounted inside pump compartment	1		7316		
Hose, 160	Pump to Jack, Left Front	1	Brown	7320		
Hose, 240	Pump to Jack, Left Rear	1	Orange	7295		
Hose, 200	Pump to Jack, Right Front	1	White	7321		
Hose, 280	Pump to Jack, Right Rear	1	Yellow	7297		
Hose, 24	Pump to flow divider	1	Green	7310		Inside pump compartment
Hose w90, 140	Flow divider to front slide, Room 1	1	Green	7311		95 / Drivers Side
Hose w90, 140	Flow divider to rear slide, Room 1	1	Green	7311		166 / Drivers Side
Hose, N/A	Pump to Room 1	N/A	Green	N/A		N/A
Hose, N/A	Pump to Room 2	N/A	Purple	N/A	N/A	
Hose, N/A	Pump to Room 3	N/A	Gray	N/A	N/A	
Hose, N/A	Pump to Room 4	N/A	Red	N/A	N/A	
Hose, N/A	Pump to Generator Slide	N/A	N/A	N/A	N/A	
Travel Clamp	Two per Slide (except bed slide)	2		HWH	N/A	

Options

Revisions

1	Omit hoses erroneously entered for room 2.				

**36A WINDSPORT (19.5) TIRES
36A MAGELLAN (22.5) TIRES
EQUALIZER JACKS (FULLY AUTOMATIC)
STANDARD ON THIS UNIT**

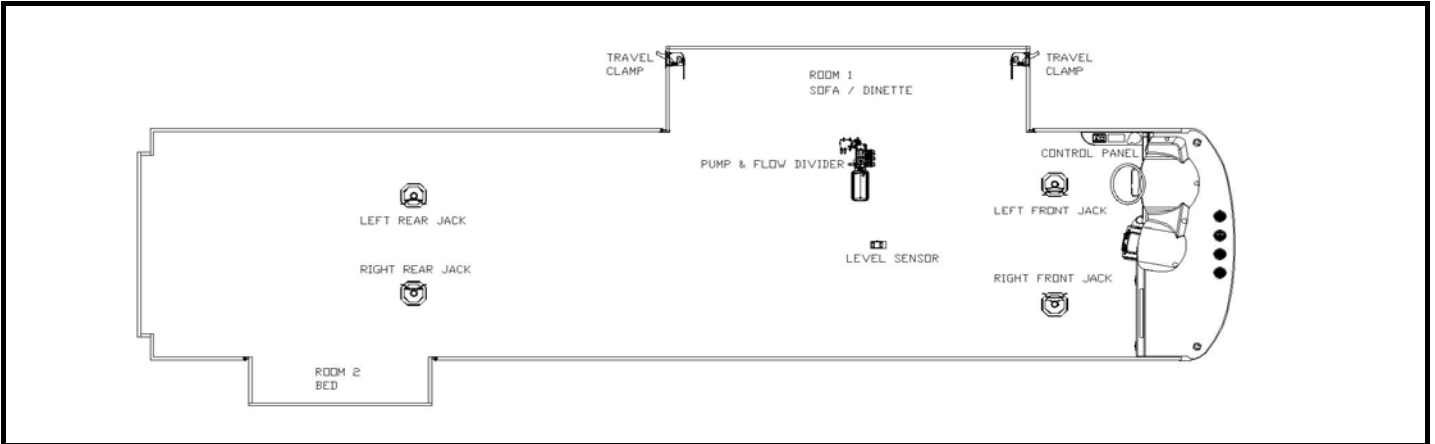

Notes:

- 1) Jacks mount in two different locations on bracket depending on tire size of chassis.
 - a) 19.5 Tires: Top hole in jack to top hole in bracket. Use 4 bolts in welded area of bracket.
 - b) 22.5 Tires: Top hole in jack to second hole in bracket. Use 6 bolts, 4 in welded area of bracket & 2 below welded area.

Item, Length	Description / Location	Qty	Color	Vendor PN		
Kit	(Items listed below)	1		8287	Measuring from inside of firewall, this is the end location of the hydraulic hoses where they attach to the slide mechanism.	
Pump	6-Function, 2 Rooms & Jacks	1		7243		
Jack	12,000 lbs, 16" Stroke	4		7214		
Control Panel	Located to the left of the drivers seat	1		2057		
Level Sensor	Attached to bottom of structure	1		7196		
Flow Divider	Mounted inside pump compartment	1		7316		
Hose, 140	Pump to Jack, Left Front	1	Brown	7294		
Hose, 264	Pump to Jack, Left Rear	1	Orange	7322		
Hose, 180	Pump to Jack, Right Front	1	White	7296		
Hose, 300	Pump to Jack, Right Rear	1	Yellow	7323		
Hose, 24	Pump to flow divider	1	Green	7310		Inside pump compartment
Hose w90, 140	Flow divider to front slide, Room 1	1	Green	7311		95 / Drivers Side
Hose w90, 140	Flow divider to rear slide, Room 1	1	Green	7311		166 / Drivers Side
Hose, N/A	Pump to Room 1	N/A	Green	N/A		N/A
Hose, 364	Pump to Room 2	1	Purple	7300	301 / Passenger Side	
Hose, N/A	Pump to Room 3	N/A	Gray	N/A	N/A	
Hose, N/A	Pump to Room 4	N/A	Red	N/A	N/A	
Hose, N/A	Pump to Generator Slide	N/A		N/A	N/A	
Travel Clamp	Two per Slide (except bed slide)	2		HWH	N/A	

Options

Revisions

**36E WINDSPORT (19.5) TIRES
36E MAGELLAN (22.5) TIRES
EQUALIZER JACKS (FULLY AUTOMATIC)
STANDARD ON THIS UNIT**

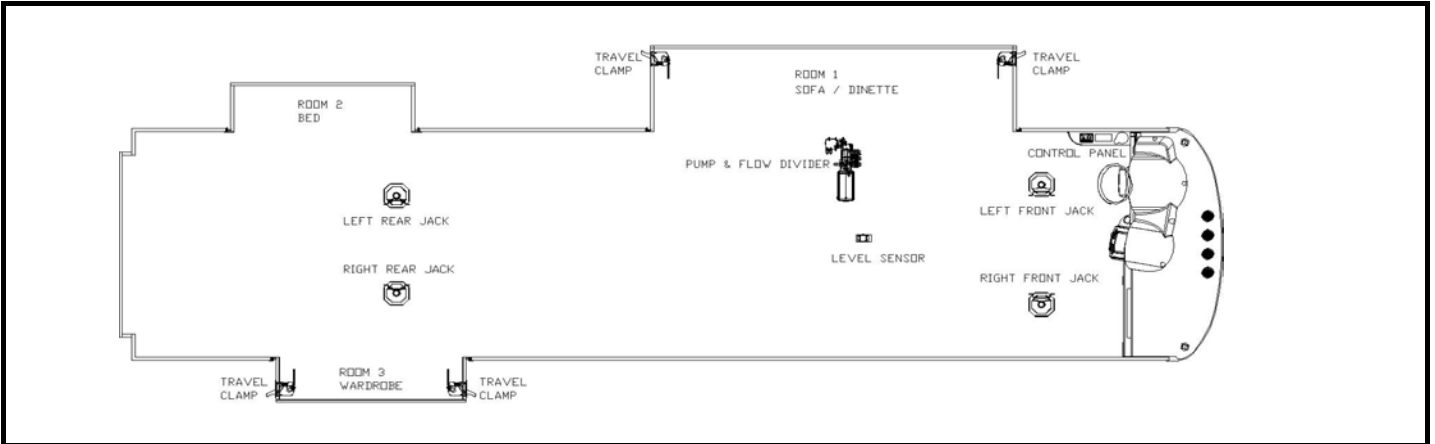

Notes:

- 1) Jacks mount in two different locations on bracket depending on tire size of chassis.
 - a) 19.5 Tires: Top hole in jack to top hole in bracket. Use 4 bolts in welded area of bracket.
 - b) 22.5 Tires: Top hole in jack to second hole in bracket. Use 6 bolts, 4 in welded area of bracket & 2 below welded area.

Item, Length	Description / Location	Qty	Color	Vendor PN		
Kit	(Items listed below)	1		8288	Measuring from inside of firewall, this is the end location of the hydraulic hoses where they attach to the slide mechanism.	
Pump	7-Function, 3 Rooms & Jacks	1		7301		
Jack	12,000 lbs, 16" Stroke	4		7214		
Control Panel	Located to the left of the drivers seat	1		2057		
Level Sensor	Attached to bottom of structure	1		7196		
Flow Divider	Mounted inside pump compartment	1		7316		
Hose, 140	Pump to Jack, Left Front	1	Brown	7294		
Hose, 264	Pump to Jack, Left Rear	1	Orange	7322		
Hose, 180	Pump to Jack, Right Front	1	White	7296		
Hose, 300	Pump to Jack, Right Rear	1	Yellow	7323		
Hose, 24	Pump to flow divider	1	Green	7310		Inside pump compartment
Hose w90, 140	Flow divider to front slide, Room 1	1	Green	7311		95 / Drivers Side
Hose w90, 140	Flow divider to rear slide, Room 1	1	Green	7311		166 / Drivers Side
Hose, N/A	Pump to Room 1	N/A	Green	N/A		N/A
Hose, 364	Pump to Room 2	1	Purple	7300	319 / Drivers Side	
Hose, 364	Pump to Room 3	1	Gray	7324	319 / Passenger Side	
Hose, N/A	Pump to Room 4	N/A	Red	N/A	N/A	
Hose, N/A	Pump to Generator Slide	N/A	N/A	N/A	N/A	
Travel Clamp	Two per Slide (except bed slide)	4		HWH	N/A	

Options

Item, Length	Description / Location	Qty	Color	Vendor PN	

Revisions

Rev	Description

**36K WINDSPORT (19.5) TIRES
36K MAGELLAN (22.5) TIRES
EQUALIZER JACKS (FULLY AUTOMATIC)
STANDARD ON THIS UNIT**

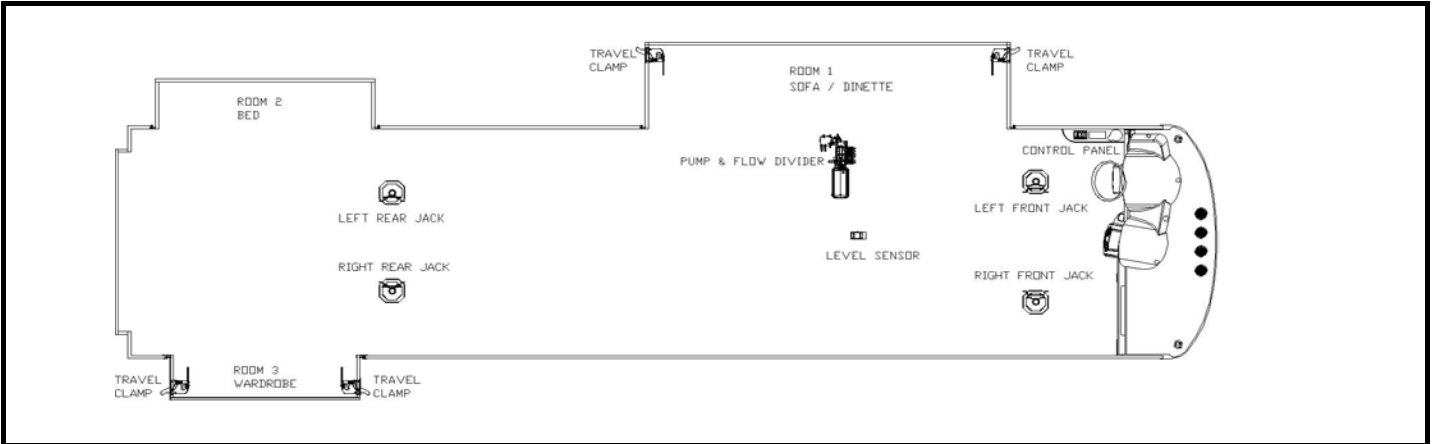

Notes:

- 1) Jacks mount in two different locations on bracket depending on tire size of chassis.
 - a) 19.5 Tires: Top hole in jack to top hole in bracket. Use 4 bolts in welded area of bracket.
 - b) 22.5 Tires: Top hole in jack to second hole in bracket. Use 6 bolts, 4 in welded area of bracket & 2 below welded area.

Item, Length	Description / Location	Qty	Color	Vendor PN		
Kit	(Items listed below)	1		8289	Measuring from inside of firewall, this is the end location of the hydraulic hoses where they attach to the slide mechanism.	
Pump	7-Function, 3 Rooms & Jacks	1		7301		
Jack	12,000 lbs, 16" Stroke	4		7214		
Control Panel	Located to the left of the drivers seat	1		2057		
Level Sensor	Attached to bottom of structure	1		7196		
Flow Divider	Mounted inside pump compartment	1		7316		
Hose, 140	Pump to Jack, Left Front	1	Brown	7294		
Hose, 264	Pump to Jack, Left Rear	1	Orange	7322		
Hose, 180	Pump to Jack, Right Front	1	White	7296		
Hose, 300	Pump to Jack, Right Rear	1	Yellow	7323		
Hose, 24	Pump to flow divider	1	Green	7310		Inside pump compartment
Hose w90, 140	Flow divider to front slide, Room 1	1	Green	7311		95 / Drivers Side
Hose w90, 140	Flow divider to rear slide, Room 1	1	Green	7311		166 / Drivers Side
Hose, N/A	Pump to Room 1	N/A	Green	N/A	N/A	
Hose, 364	Pump to Room 2	1	Purple	7300	340 / Drivers Side	
Hose, 364	Pump to Room 3	1	Gray	7324	323 / Passenger Side	
Hose, N/A	Pump to Room 4	N/A	Red	N/A	N/A	
Hose, N/A	Pump to Generator Slide	N/A	N/A	N/A	N/A	
Travel Clamp	Two per Slide (except bed slide)	4		HWH	N/A	

Options

Revisions

**36Z WINDSPORT (19.5) TIRES
36Z MAGELLAN (22.5) TIRES
EQUALIZER JACKS (FULLY AUTOMATIC)
STANDARD ON THIS UNIT**

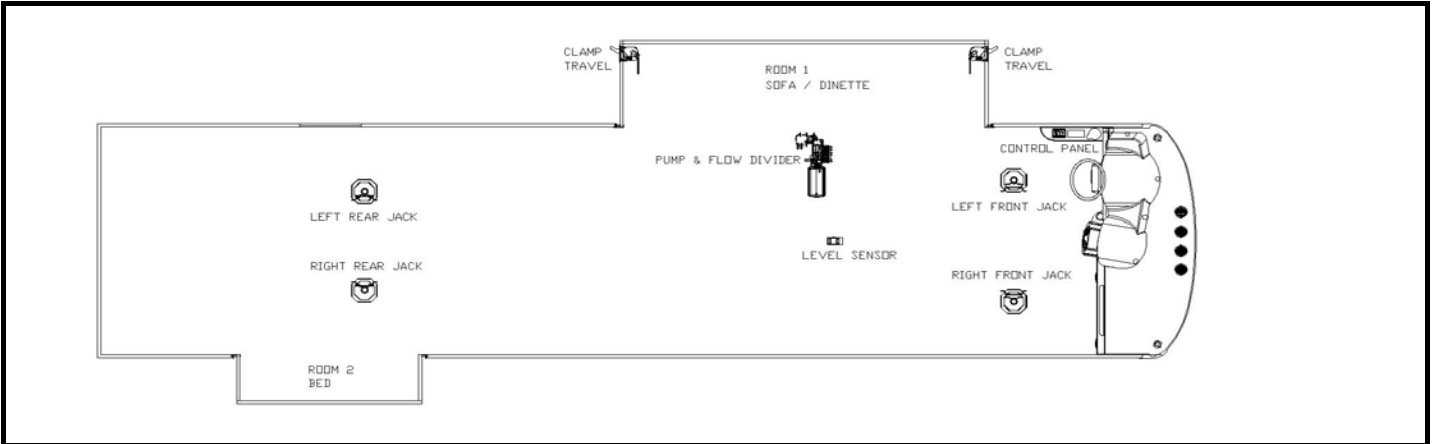

Notes:

- 1) Jacks mount in two different locations on bracket depending on tire size of chassis.
 - a) 19.5 Tires: Top hole in jack to top hole in bracket. Use 4 bolts in welded area of bracket.
 - b) 22.5 Tires: Top hole in jack to second hole in bracket. Use 6 bolts, 4 in welded area of bracket & 2 below welded area.

Item, Length	Description / Location	Qty	Color	Vendor PN		
Kit	(Items listed below)	1		8290	Measuring from inside of firewall, this is the end location of the hydraulic hoses where they attach to the slide mechanism.	
Pump	6-Function, 2 Rooms & Jacks	1		7243		
Jack	12,000 lbs, 16" Stroke	4		7214		
Control Panel	Located to the left of the drivers seat	1		2057		
Level Sensor	Attached to bottom of structure	1		7196		
Flow Divider	Mounted inside pump compartment	1		7316		
Hose, 140	Pump to Jack, Left Front	1	Brown	7294		
Hose, 264	Pump to Jack, Left Rear	1	Orange	7322		
Hose, 180	Pump to Jack, Right Front	1	White	7296		
Hose, 300	Pump to Jack, Right Rear	1	Yellow	7323		
Hose, 24	Pump to flow divider	1	Green	7310		Inside pump compartment
Hose w90, 140	Flow divider to front slide, Room 1	1	Green	7311		95 / Drivers Side
Hose w90, 140	Flow divider to rear slide, Room 1	1	Green	7311		166 / Drivers Side
Hose, N/A	Pump to Room 1	N/A	Green	N/A		N/A
Hose, 364	Pump to Room 2	1	Purple	7300	319 / Passenger Side	
Hose, N/A	Pump to Room 3	N/A	Gray	N/A	N/A	
Hose, N/A	Pump to Room 4	N/A	Red	N/A	N/A	
Hose, N/A	Pump to Generator Slide	N/A		N/A	N/A	
Travel Clamp	Two per Slide (except bed slide)	2		HWH	N/A	

Options

Revisions

**38E MAGELLAN (22.5) TIRES
EQUALIZER JACKS (FULLY AUTOMATIC)
STANDARD ON THIS UNIT**

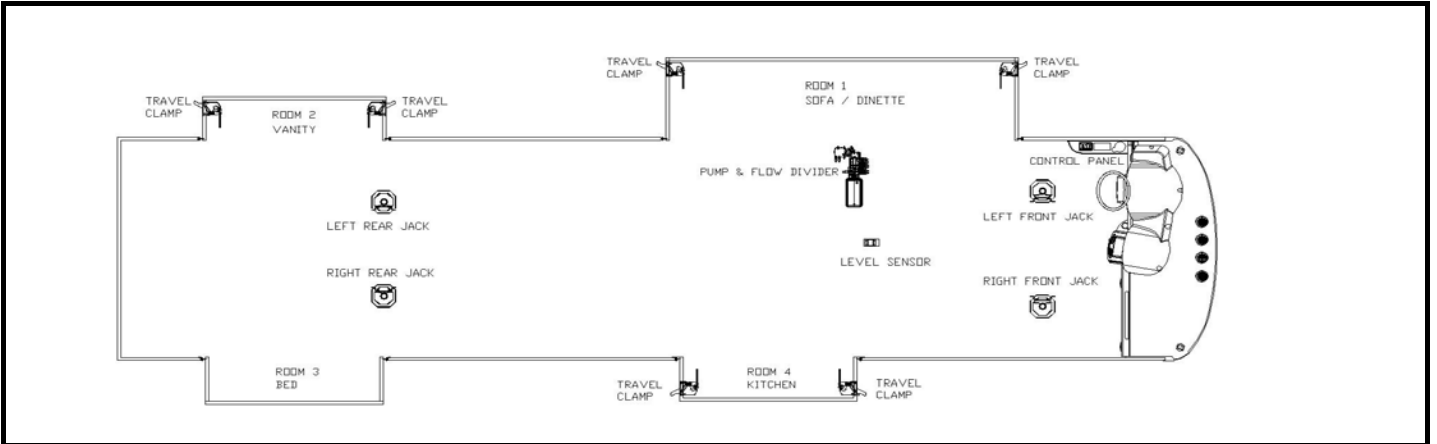

Notes:

- 1) Jacks mount in two different locations on bracket depending on tire size of chassis.
 - a) 19.5 Tires: Top hole in jack to top hole in bracket. Use 4 bolts in welded area of bracket.
 - b) 22.5 Tires: Top hole in jack to second hole in bracket. Use 6 bolts, 4 in welded area of bracket & 2 below welded area.

Item, Length	Description / Location	Qty	Color	Vendor PN		
Kit	(Items listed below)	1		8291	Measuring from inside of firewall, this is the end location of the hydraulic hoses where they attach to the slide mechanism.	
Pump	8-Function, 4 Rooms & Jacks	1		7302		
Jack	12,000 lbs, 16" Stroke	4		7214		
Control Panel	Located to the left of the drivers seat	1		2057		
Level Sensor	Attached to bottom of structure	1		7196		
Flow Divider	Mounted inside pump compartment	1		7316		
Hose, 140	Pump to Jack, Left Front	1	Brown	7294		
Hose, 282	Pump to Jack, Left Rear	1	Orange	7325		
Hose, 180	Pump to Jack, Right Front	1	White	7296		
Hose, 318	Pump to Jack, Right Rear	1	Yellow	7326		
Hose, 24	Pump to flow divider	1	Green	7310		Inside pump compartment
Hose w90, 140	Flow divider to front slide, Room 1	1	Green	7311		95 / Drivers Side
Hose w90, 140	Flow divider to rear slide, Room 1	1	Green	7311		166 / Drivers Side
Hose, N/A	Pump to Room 1	N/A	Green	N/A	N/A	
Hose, 364	Pump to Room 2	1	Purple	7300	356 / Drivers Side	
Hose, 396	Pump to Room 3	1	Gray	7327	344 / Passenger Side	
Hose, 110	Pump to Room 4	1	Red	7328	160 / Passenger Side	
Hose, N/A	Pump to Generator Slide	N/A		N/A	N/A	
Travel Clamp	Two per Slide (except bed slide)	6		HWH	N/A	

Options

Revisions

**39A Presidio
EQUALIZER JACKS (FULLY AUTOMATIC)
STANDARD ON THIS UNIT**

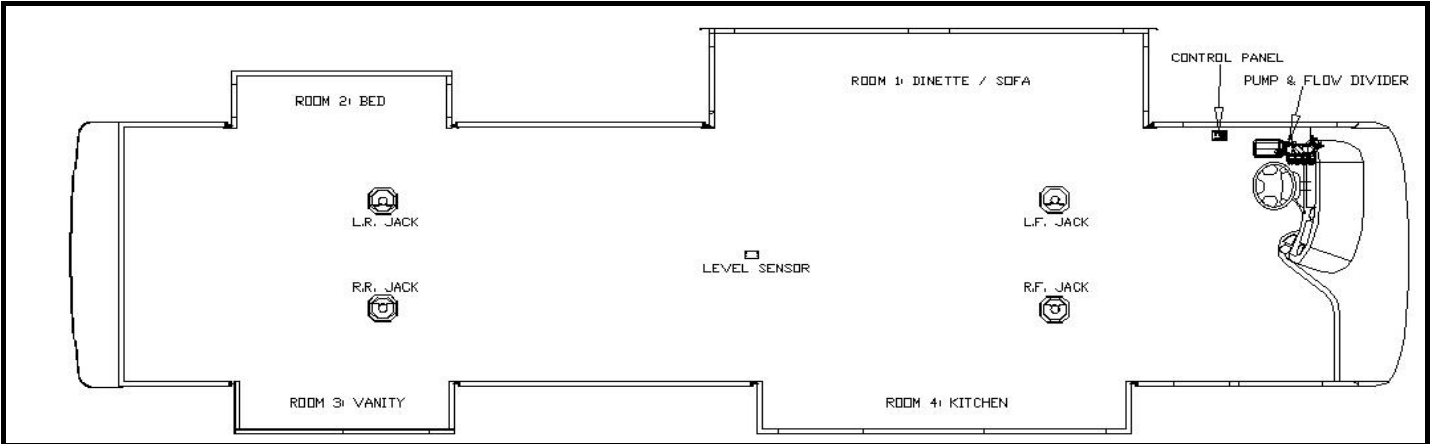

Notes:

- 1) Jacks mount to chassis brackets with the lowest holes of the jacks aligned with the lowest holes of the mounting brackets.
- 2) Level sensor attaches to bottom of structure; on the square tube the runs full length from axle to axle.
- 3) Hydraulic hose terminations for room #1, #3, & #4 require 90 degree swivel elbows.
- 4) Reference FM-3991 for a better visual of Room 1 hydraulic connections.

Item, Length	Description / Location	Qty	Color	Vendor PN		
Kit	(Items listed below)	1		8294	Measuring from inside of firewall, this is the end location of the hydraulic hoses where they attach to the slide mechanism.	
Pump	8-Function, 4 Rooms & Jacks	1		7302		
Jack	17,000 lbs, 18" Stroke	4		7134		
Control Panel	Located to the left of the drivers seat	1		2057		
Level Sensor	Attached to bottom of structure	1		7196		
Sync Cylinder	Mounted ?	1		7351		
Hose, 140	Pump to Jack, Left Front	2	Brown	7294		
Hose, 396	Pump to Jack, Left Rear	2	Orange	7342		
Hose, 140	Pump to Jack, Right Front	2	White	7308		
Hose, 396	Pump to Jack, Right Rear	2	Yellow	7341		
Hose, 140	Pump to synchronizing cylinder	2	Green	7311		Mounts to bracket on structure
Hose w90, 170	Sync cylinder to front slide, Room 1	2	Green	2415		103 / Drivers side
Hose w90, 170	Sync cylinder to rear slide, Room 1	2	Green	2415		196 / Drivers side
	Pump to Room 1	N/A	Green			
Hose, 475	Pump to Room 2	2	Purple	7338	340 / Drivers Side	
Hose w90, 425	Pump to Room 3	2	Gray	7337	365 / Passenger Side	
Hose w90, 220	Pump to Room 4	2	Red	7336	146 / Passenger Side	
	Pump to Generator Slide	N/A			N/A	
Travel Clamp	(two per slide, except the bed slide)	6		HWH	N/A	

Options

Item, Length	Description / Location	Qty	Color	Vendor PN	

Revisions

	Beginning with release of 1/23/06 and documented on ECN #3845

39B Presidio
EQUALIZER JACKS (FULLY AUTOMATIC)
STANDARD ON THIS UNIT

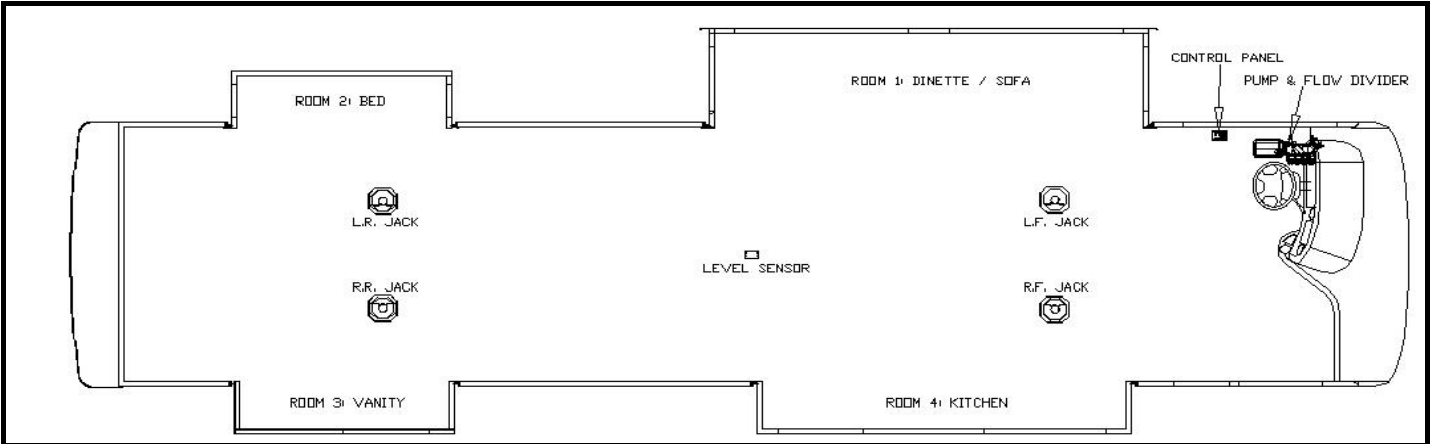

Notes:

- 1) Jacks mount to chassis brackets with the lowest holes of the jacks aligned with the lowest holes of the mounting brackets.
- 2) Level sensor attaches to bottom of structure; on the square tube the runs full length from axle to axle.
- 3) Hydraulic hose terminations for room #1, #3, & #4 require 90 degree swivel elbows.
- 4) Reference FM-3991 for a better visual of Room 1 hydraulic connections.

Item, Length	Description / Location	Qty	Color	Vendor PN	
Kit	(Items listed below)	1		8294	
Pump	8-Function, 4 Rooms & Jacks	1		7302	
Jack	17,000 lbs, 18" Stroke	4		7134	
Control Panel	Located to the left of the drivers seat	1		2057	
Level Sensor	Attached to bottom of structure	1		7196	
Sync Cylinder	Mounted ?	1		7351	
Hose, 140	Pump to Jack, Left Front	2	Brown	7294	
Hose, 396	Pump to Jack, Left Rear	2	Orange	7342	
Hose, 140	Pump to Jack, Right Front	2	White	7308	
Hose, 396	Pump to Jack, Right Rear	2	Yellow	7341	
Hose, 140	Pump to synchronizing cylinder	2	Green	7311	Mounts to bracket on structure
Hose w90, 170	Sync cylinder to front slide, Room 1	2	Green	2415	103 / Drivers side
Hose w90, 170	Sync cylinder to rear slide, Room 1	2	Green	2415	196 / Drivers side
	Pump to Room 1	N/A	Green		
Hose, 475	Pump to Room 2	2	Purple	7338	340 / Drivers Side
Hose w90, 425	Pump to Room 3	2	Gray	7337	365 / Passenger Side
Hose w90, 220	Pump to Room 4	2	Red	7336	155 / Passenger Side
	Pump to Generator Slide	N/A			N/A
Travel Clamp	(two per slide, except the bed slide)	6		HWH	N/A

Measuring from inside of firewall, this is the end location of the hydraulic hoses where they attach to the slide mechanism.

Options

Revisions

	Beginning with release of 1/23/06 and documented on ECN #3845

39C Presidio
EQUALIZER JACKS (FULLY AUTOMATIC)
STANDARD ON THIS UNIT

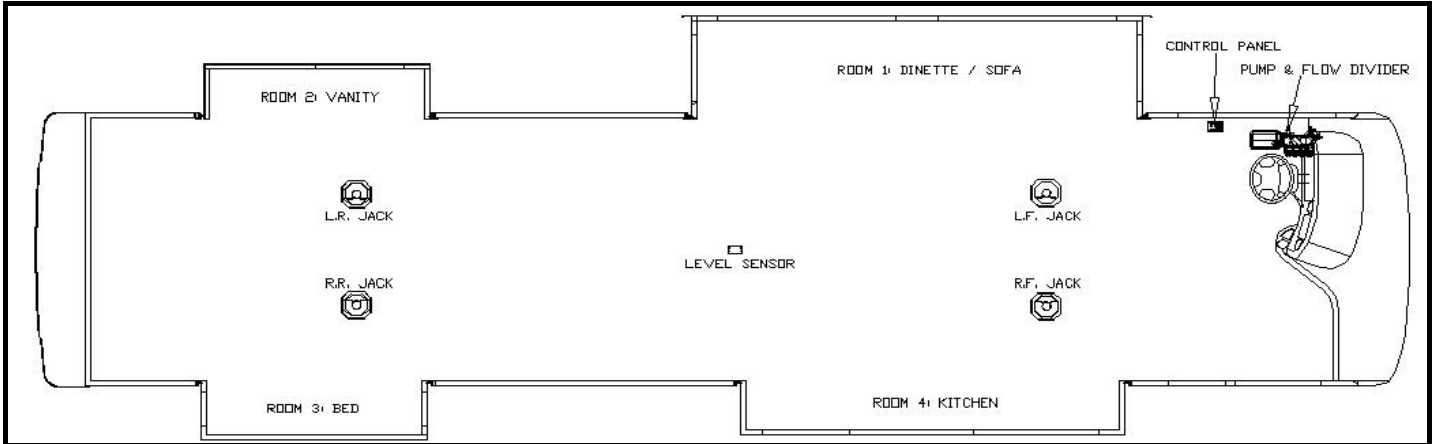

- Notes:**
- 1) Jacks mount to chassis brackets with the lowest holes of the jacks aligned with the lowest holes of the mounting brackets.
 - 2) Level sensor attaches to bottom of structure; on the square tube the runs full length from axle to axle.
 - 3) Hydraulic hose terminations for room #1, #2, & #4 require 90 degree swivel elbows.
 - 4) Reference FM-3991 for a better visual of Room 1 hydraulic connections.

Item, Length	Description / Location	Qty	Color	Vendor PN	
Kit	(Items listed below)	1		8293	
Pump	8-Function, 4 Rooms & Jacks	1		7302	
Jack	17,000 lbs, 18" Stroke	4		7134	
Control Panel	Located to the left of the drivers seat	1		2057	
Level Sensor	Attached to bottom of structure	1		7196	
Sync Cylinder	Mounted ?	1		7351	
Hose, 140	Pump to Jack, Left Front	2	Brown	7294	
Hose, 396	Pump to Jack, Left Rear	2	Orange	7342	
Hose, 140	Pump to Jack, Right Front	2	White	7308	
Hose, 396	Pump to Jack, Right Rear	2	Yellow	7341	
Hose, 140	Pump to synchronizing cylinder	2	Green	7311	Mounts to bracket on structure
Hose w90, 170	Sync cylinder to front slide, Room 1	2	Green	2415	103 / Drivers side
Hose w90, 170	Sync cylinder to rear slide, Room 1	2	Green	2415	196 / Drivers side
	Pump to Room 1	N/A	Green		
Hose w90, 425	Pump to Room 2	2	Purple	7335	350 / Drivers Side
Hose, 475	Pump to Room 3	2	Gray	7334	345 / Passenger Side
Hose w90, 220	Pump to Room 4	2	Red	7336	146 / Passenger Side
	Pump to Generator Slide	N/A			N/A
Travel Clamp	(two per slide, except the bed slide)	6		HWH	N/A

Measuring from inside of firewall, this is the end location of the hydraulic hoses where they attach to the slide mechanism.

Options

Revisions

	Beginning with release of 1/23/06 and documented on ECN #3845

**39D Presidio
EQUALIZER JACKS (FULLY AUTOMATIC)
STANDARD ON THIS UNIT**

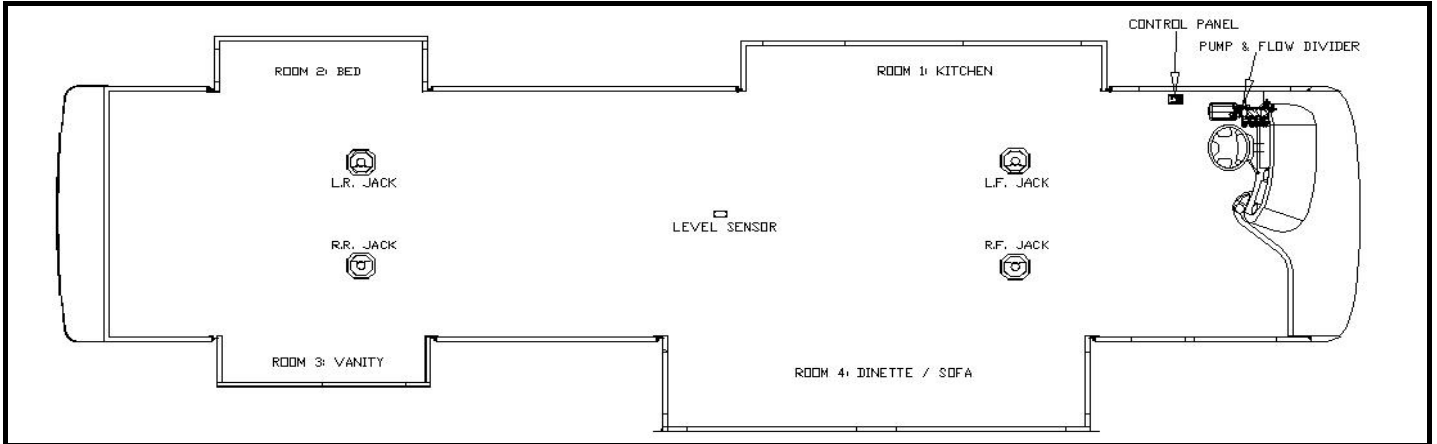

- Notes:**
- 1) Jacks mount to chassis brackets with the lowest holes of the jacks aligned with the lowest holes of the mounting brackets.
 - 2) Level sensor attaches to bottom of structure; on the square tube the runs full length from axle to axle.
 - 3) Hydraulic hose terminations for room #1, #3, & #4 require 90 degree swivel elbows.
 - 4) Reference FM-3991 for a better visual of Room 4 hydraulic connections.

Item, Length	Description / Location	Qty	Color	Vendor PN	
Kit	(Items listed below)	1		8292	
Pump	8-Function, 4 Rooms & Jacks	1		7302	
Jack	17,000 lbs, 18" Stroke	4		7134	
Control Panel	Located to the left of the drivers seat	1		2057	
Level Sensor	Attached to bottom of structure	1		7196	
Sync Cylinder	Mounted ?	1		7351	
Hose, 140	Pump to Jack, Left Front	2	Brown	7294	
Hose, 396	Pump to Jack, Left Rear	2	Orange	7342	
Hose, 140	Pump to Jack, Right Front	2	White	7308	
Hose, 396	Pump to Jack, Right Rear	2	Yellow	7341	
Hose, 140	Pump to synchronizing cylinder	2	Red	2426	Mounts to bracket on structure
Hose w90, 140	Pump to Room 1	2	Green	7311	149 / Drivers side
Hose, 475	Pump to Room 2	2	Purple	7338	325 / Drivers Side
Hose w90, 425	Pump to Room 3	2	Gray	7337	355 / Passenger Side
Hose w90, 170	Sync cylinder to front slide, Room 4	2	Red	2425	103 / Passenger side
Hose w90, 170	Sync cylinder to rear slide, Room 4	2	Red	2425	196 / Passenger side
	Pump to Generator Slide	N/A			N/A
Travel Clamp	(two per slide, except the bed slide)	6		HWH	N/A

Measuring from inside of firewall, this is the end location of the hydraulic hoses where they attach to the slide mechanism.

Options					

Revisions	
	Beginning with release of 1/23/06 and documented on ECN #3845

8251-LEVELING SYS-FULL AUTO(JACKS ONLY)

PART NO.	DESCRIPTION	QUAN
1124	#4 JIC X #4 O-RING MALE 90	4
1403	RESTRICTOR FITTING #6 X #4	4
2057	CONTROL PANEL AUTO LEVEL PS M894-02-60	1
6569	HARNESS, FOUR WINDS MOTOR HOME 35'	1
7196	AUTO LEVEL SENSOR ASSEMBLY	1
7214	MH 16 SL LEG	4
7239	PUMP & MAN 4 FUN. 3.7 MAN P.S.	1
7247	HOSE KIT-PUMP TO L/F JACK-300" FM-3676-B	1
7248	HOSE KIT-PUMP TO L/R JACK-100" FM-3676-C	1
7251	HOSE KIT-PUMP TO R/F JACK-269" FM-3676-F	1
7253	HOSE KIT-PUMP TO R/R JACK-60" FM-3676-H	1

8250-SLIDE SYSTEM (1 ROOM) FM-3677 (SUGGESTED-SINGLE SLIDE PUMP KIT)

PART NO.	DESCRIPTION	QUAN
6569	HARNESS, FOUR WINDS MOTOR HOME 35'	1
7242	PUMP & MAN 5 FUNC 3.7 MAN P.S.	1
7254	HOSE KIT-PUMP TO SLIDE-84" FM-3676-I	1

8253-LEVELING SYS-FULL AUTO (JACKS & 1 ROOM) FM-3680

PART NO.	DESCRIPTION	QUAN
1124	#4 JIC X #4 O-RING MALE 90	4
1403	RESTRICTOR FITTING #6 X #4	4
2057	CONTROL PANEL AUTO LEVEL PS M894-02-60	1
7196	AUTO LEVEL SENSOR ASSEMBLY	1
7214	MH 16 SL LEG	4
7246	HOSE KIT-PUMP TO L/F JACK-126" FM-3676-A	1
7249	HOSE KIT-PUMP TO L/R JACK-223" FM-3676-D	1
7250	HOSE KIT-PUMP TO R/F JACK-162" FM-3676-E	1
7252	HOSE KIT-PUMP TO R/R JACK-269" FM-3676-G	1

7164-SLIDE ASSEMBLY 36" FM-3655

	<u>FOUR WINDS #</u>	<u>EQUALIZER #</u>
LEVELING CONTROL TOUCH PANEL	SE-1315	2057
LEVEL CONTROL SENSOR MODULE	SE-1316	7196
HOSE KIT (PUMP TO JACKS)	FM-3659	2055
HOSE KIT (PUMP TO SLIDE)	FM-3661	2056
HARNESS (PUMP TO SWITCH)	SE-1312	6569
HARNESS (PUMP TO SLIDE MECHANISM)	SE-1313	6571
HARNESS (SENSOR MODULE TO SWITCH)	SE-1314	1616
18" SLIDE MECHANISM	FM-3653	7135
36" SLIDE MECHANISM	FM-3654	7164
SINGLE MANIFOLD PUMP (JACKS ONLY)	FM-3655	7239
DUAL MANIFOLD PUMP (JACKS & 1 ROOM)	FM-3656	7242
TRIPLE MANIFOLD PUMP (JACKS & 2 ROOMS)	FM-3657	7243
12,000 JACK (16" STROKE, 2.5" BORE)	FM-3658	7214

**33C FUNMOVER
EQUALIZER JACKS (FULLY AUTOMATIC)
OPTIONAL ON THIS UNIT**



Notes:

1) Jacks mount 2nd hole from top to top mounting plate hole.

Item, Length	Description / Location	Qty	Color	Vendor PN	
Kit	(Items listed below)	1		8251	Measuring from back of cab floor, this is the end location of the hydraulic hoses where they attach to the slide mechanism.
Pump	4-Function, Jacks Only	1		7239	
Jack	12,000 lbs, 16" Stroke	4		7214	
Touch Pad	Located to the right of the drivers seat	1		2318	
Control Box	Attached to bottom of structure	1		2319	
Flow Divider	Mounted inside pump compartment	N/A		N/A	
Hose, 300	Pump to Jack, Left Front	2	Brown	2479	
Hose, 108	Pump to Jack, Left Rear	2	Orange	2464	
Hose, 276	Pump to Jack, Right Front	2	White	2477	
Hose, 60	Pump to Jack, Right Rear	2	Yellow	2460	
Hose, N/A	Pump to Flow Divider	N/A	TBD	N/A	N/A
Hose, N/A	Flow divider to front slide, Room 1	N/A	TBD	N/A	N/A
Hose, N/A	Flow divider to rear slide, Room 1	N/A	TBD	N/A	N/A
Hose, N/A	Pump to Room 1	N/A	Green	N/A	N/A
Hose, N/A	Pump to Room 2	N/A	Purple	N/A	N/A
Hose, N/A	Pump to Room 3	N/A	Gray	N/A	N/A
Hose, N/A	Pump to Room 4	N/A	Red	N/A	N/A
Hose, N/A	Pump to Generator Slide	N/A	TBD	N/A	N/A
Travel Clamp	Two per Slide	N/A		HWH	N/A
Options					
Revisions	Description		By	Date	

**34C FUNMOVER
EQUALIZER JACKS (FULLY AUTOMATIC)
OPTIONAL ON THIS UNIT**

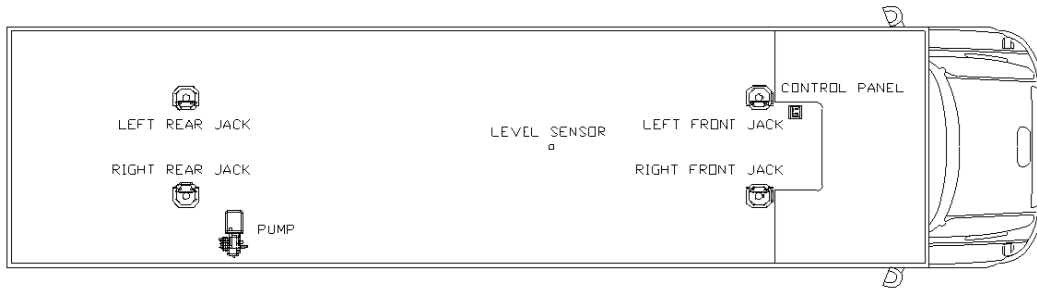

Notes:

1) Jacks mount 2nd hole from top to top mounting plate hole.

Item, Length	Description / Location	Qty	Color	Vendor PN	
Kit	(Items listed below)	1		8251	Measuring from back of cab floor, this is the end location of the hydraulic hoses where they attach to the slide mechanism.
Pump	4-Function, Jacks Only	1		7239	
Jack	12,000 lbs, 16" Stroke	4		7214	
Touch Pad	Located to the right of the drivers seat	1		2318	
Control Box	Attached to bottom of structure	1		2319	
Flow Divider	Mounted inside pump compartment	N/A		N/A	
Hose, 300	Pump to Jack, Left Front	2	Brown	2479	
Hose, 108	Pump to Jack, Left Rear	2	Orange	2464	
Hose, 276	Pump to Jack, Right Front	2	White	2477	
Hose, 60	Pump to Jack, Right Rear	2	Yellow	2460	
Hose, N/A	Pump to Flow Divider	N/A	TBD	N/A	N/A
Hose, N/A	Flow divider to front slide, Room 1	N/A	TBD	N/A	N/A
Hose, N/A	Flow divider to rear slide, Room 1	N/A	TBD	N/A	N/A
Hose, N/A	Pump to Room 1	N/A	Green	N/A	N/A
Hose, N/A	Pump to Room 2	N/A	Purple	N/A	N/A
Hose, N/A	Pump to Room 3	N/A	Gray	N/A	N/A
Hose, N/A	Pump to Room 4	N/A	Red	N/A	N/A
Hose, N/A	Pump to Generator Slide	N/A	TBD	N/A	N/A
Travel Clamp	Two per Slide	N/A		HWH	N/A
Options					
Revisions	Description			By	Date

39C FUN MOVER
EQUALIZER JACKS (FULLY AUTOMATIC)
OPTIONAL ON THIS UNIT

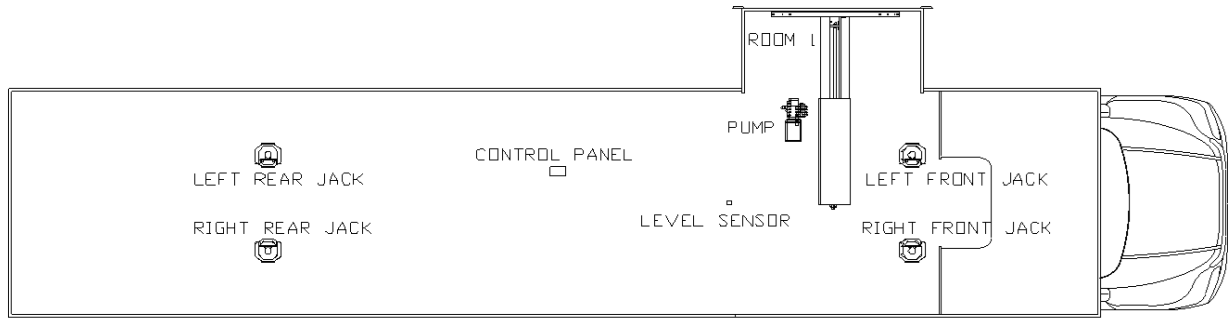

Notes:

1) Jacks mount top hole to 2nd from top mounting plate hole.

Item, Length	Description / Location	Qty	Color	Vendor PN	Measuring from back of cab floor, this is the end location of the hydraulic hoses where they attach to the slide mechanism.
Kit	(Items listed below)	1		8250	
Pump	5-Function, 1 Room, Jacks	1		7242	
Flow Divider	Mounted inside pump compartment	N/A		N/A	
Hose, N/A	Pump to Flow Divider	N/A	TBD	N/A	N/A
Hose, N/A	Flow divider to front slide, Room 1	N/A	TBD	N/A	N/A
Hose, N/A	Flow divider to rear slide, Room 1	N/A	TBD	N/A	N/A
Hose, 84	Pump to Room 1	2	Green	2462	42 / Drivers Side
Hose, N/A	Pump to Room 2	N/A	Purple	N/A	N/A
Hose, N/A	Pump to Room 3	N/A	Gray	N/A	N/A
Hose, N/A	Pump to Room 4	N/A	Red	N/A	N/A
Hose, N/A	Pump to Generator Slide	N/A	TBD	N/A	N/A
Travel Clamp	Two per Slide	N/A		HWH	N/A
Options					
Kit	(Items listed below)	1		8253	
Jack	12,000 lbs, 16" Stroke	4		7214	
Touch Pad	Located to the right of the drivers seat	1		2318	
Control Box	Attached to bottom of structure	1		2319	
Hose, 132	Pump to Jack, Left Front	2	Brown	2466	
Hose, 264	Pump to Jack, Left Rear	2	Orange	2476	
Hose, 168	Pump to Jack, Right Front	2	White	2469	
Hose, 276	Pump to Jack, Right Rear	2	Yellow	2477	
Revisions					

39D FUN MOVER
EQUALIZER JACKS (FULLY AUTOMATIC)
OPTIONAL ON THIS UNIT

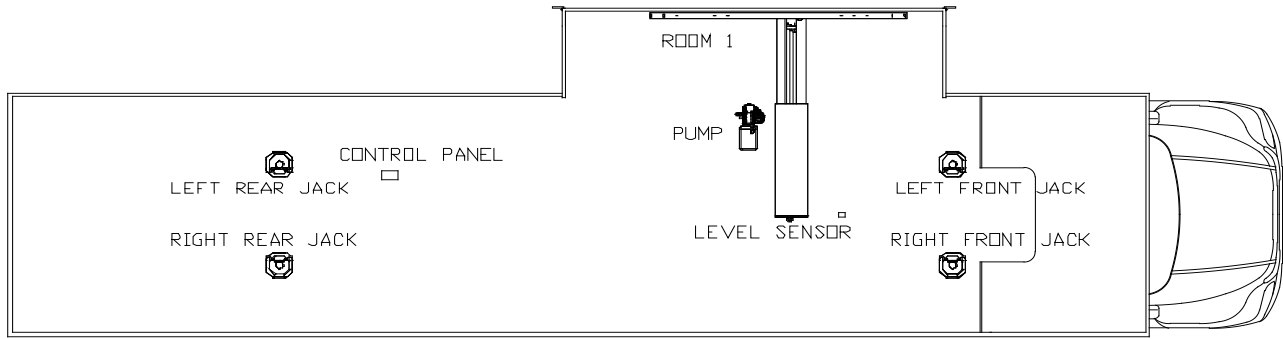

Notes:

1) Jacks mount 2nd hole from top to top mounting plate hole.

Item, Length	Description / Location	Qty	Color	Vendor PN	Measuring from back of cab floor, this is the end location of the hydraulic hoses where they attach to the slide mechanism.
Kit	(Items listed below)	1		8250	
Pump	5-Function, 1 Room, Jacks	1		7242	
Flow Divider	Mounted inside pump compartment	N/A		N/A	
Hose, N/A	Pump to Flow Divider	N/A	TBD	N/A	N/A
Hose, N/A	Flow divider to front slide, Room 1	N/A	TBD	N/A	N/A
Hose, N/A	Flow divider to rear slide, Room 1	N/A	TBD	N/A	N/A
Hose, 84	Pump to Room 1	2	Green	2462	73 / Drivers Side
Hose, N/A	Pump to Room 2	N/A	Purple	N/A	N/A
Hose, N/A	Pump to Room 3	N/A	Gray	N/A	N/A
Hose, N/A	Pump to Room 4	N/A	Red	N/A	N/A
Hose, N/A	Pump to Generator Slide	N/A	TBD	N/A	N/A
Travel Clamp	Two per Slide	N/A		HWH	N/A
Options					
Kit	(Items listed below)	1		8253	
Jack	12,000 lbs, 16" Stroke	4		7214	
Touch Pad	Located to the right of the drivers seat	1		2318	
Control Box	Attached to bottom of structure	1		2319	
Hose, 132	Pump to Jack, Left Front	2	Brown	2466	
Hose, 264	Pump to Jack, Left Rear	2	Orange	2476	
Hose, 168	Pump to Jack, Right Front	2	White	2469	
Hose, 276	Pump to Jack, Right Rear	2	Yellow	2477	
Revisions					

**34C FUNMOVER
EQUALIZER JACKS (FULLY AUTOMATIC)
OPTIONAL ON THIS UNIT**



Notes:

1) Jacks mount 2nd hole from top to top mounting plate hole.

Item, Length	Description / Location	Qty	Color	Vendor PN		
Kit	(Items listed below)	1		8251	Measuring from back of cab floor, this is the end location of the hydraulic hoses where they attach to the slide mechanism.	
Pump	4-Function, Jacks Only	1		7239		
Jack	12,000 lbs, 16" Stroke	4		7214		
Control Panel	Located to the right of the drivers seat	1		2057		
Level Sensor	Attached to bottom of structure	1		7196		
Flow Divider	Mounted inside pump compartment	N/A		N/A		
Hose, 300	Pump to Jack, Left Front	1	Brown	7247		
Hose, 100	Pump to Jack, Left Rear	1	Orange	7248		
Hose, 269	Pump to Jack, Right Front	1	White	7251		
Hose, 60	Pump to Jack, Right Rear	1	Yellow	7253		
Hose, N/A	Pump to Flow Divider	N/A	TBD	N/A		N/A
Hose, N/A	Flow divider to front slide, Room 1	N/A	TBD	N/A		N/A
Hose, N/A	Flow divider to rear slide, Room 1	N/A	TBD	N/A		N/A
Hose, N/A	Pump to Room 1	N/A	Green	N/A		N/A
Hose, N/A	Pump to Room 2	N/A	Purple	N/A		N/A
Hose, N/A	Pump to Room 3	N/A	Gray	N/A		N/A
Hose, N/A	Pump to Room 4	N/A	Red	N/A		N/A
Hose, N/A	Pump to Generator Slide	N/A	TBD	N/A		N/A
Travel Clamp	Two per Slide	N/A		HWH		N/A
Options						
Revisions	Description			By	Date	

39C FUN MOVER
EQUALIZER JACKS (FULLY AUTOMATIC)
OPTIONAL ON THIS UNIT

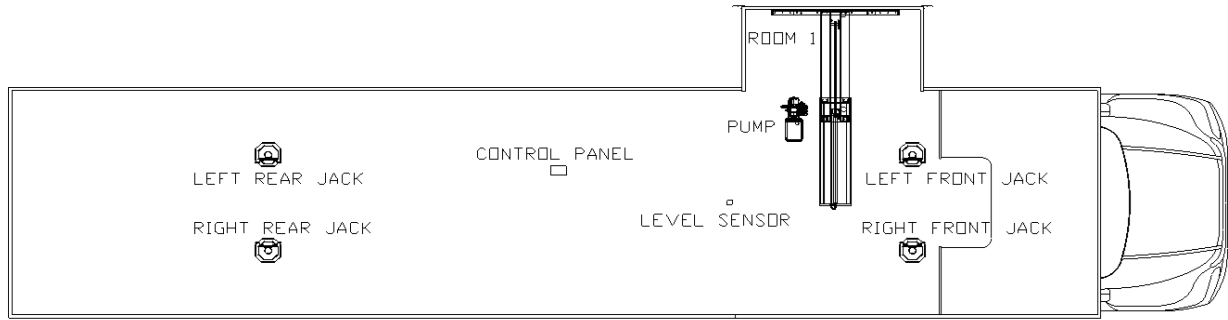

Notes:

1) Jacks mount top hole to 2nd from top mounting plate hole.

Item, Length	Description / Location	Qty	Color	Vendor PN	Measuring from back of cab floor, this is the end location of the hydraulic hoses where they attach to the slide mechanism.
Kit	(Items listed below)	1		8250	
Pump	5-Function, 1 Room, Jacks	1		7242	
Flow Divider	Mounted inside pump compartment	N/A		N/A	
Hose, N/A	Pump to Flow Divider	N/A	TBD	N/A	N/A
Hose, N/A	Flow divider to front slide, Room 1	N/A	TBD	N/A	N/A
Hose, N/A	Flow divider to rear slide, Room 1	N/A	TBD	N/A	N/A
Hose, 84	Pump to Room 1	1	Green	7254	42 / Drivers Side
Hose, N/A	Pump to Room 2	N/A	Purple	N/A	N/A
Hose, N/A	Pump to Room 3	N/A	Gray	N/A	N/A
Hose, N/A	Pump to Room 4	N/A	Red	N/A	N/A
Hose, N/A	Pump to Generator Slide	N/A	TBD	N/A	N/A
Travel Clamp	Two per Slide	N/A		HWH	N/A
Options					
Kit	(Items listed below)	1		8253	
Jack	12,000 lbs, 16" Stroke	4		7214	
Control Panel	Located to the right of the drivers seat	1		2057	
Level Sensor	Attached to bottom of structure	1		7196	
Hose, 126	Pump to Jack, Left Front	1	Brown	7246	
Hose, 256	Pump to Jack, Left Rear	1	Orange	7249	
Hose, 162	Pump to Jack, Right Front	1	White	7250	
Hose, 269	Pump to Jack, Right Rear	2	Yellow	7252	
Revisions					

39D FUN MOVER
EQUALIZER JACKS (FULLY AUTOMATIC)
OPTIONAL ON THIS UNIT

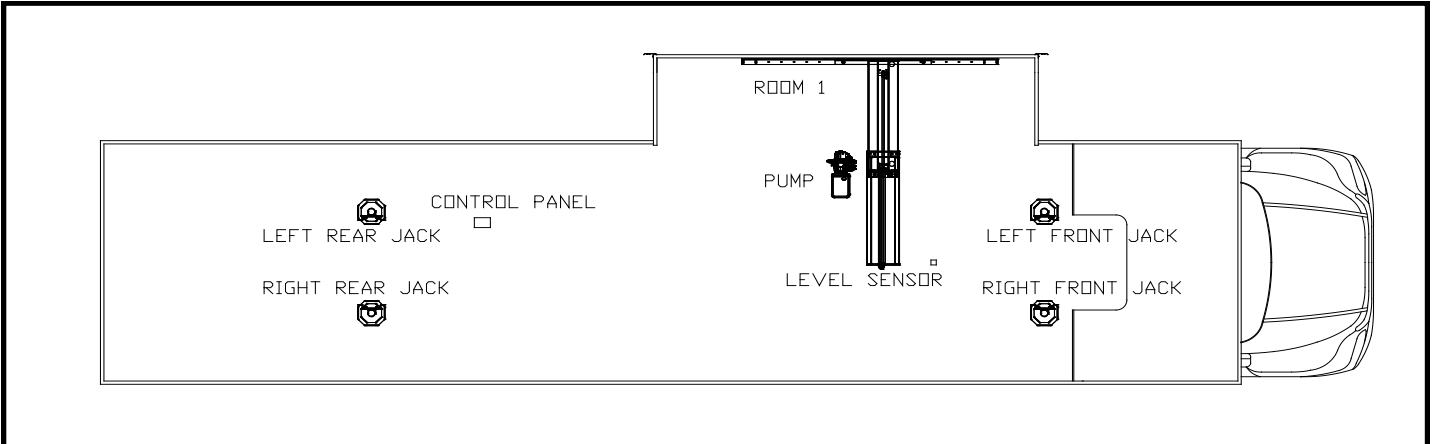

Notes:

1) Jacks mount 2nd hole from top to top mounting plate hole.

Item, Length	Description / Location	Qty	Color	Vendor PN	Measuring from back of cab floor, this is the end location of the hydraulic hoses where they attach to the slide mechanism.
Kit	(Items listed below)	1		8250	
Pump	5-Function, 1 Room, Jacks	1		7242	
Flow Divider	Mounted inside pump compartment	N/A		N/A	
Hose, N/A	Pump to Flow Divider	N/A	TBD	N/A	N/A
Hose, N/A	Flow divider to front slide, Room 1	N/A	TBD	N/A	N/A
Hose, N/A	Flow divider to rear slide, Room 1	N/A	TBD	N/A	N/A
Hose, 84	Pump to Room 1	1	Green	7254	73 / Drivers Side
Hose, N/A	Pump to Room 2	N/A	Purple	N/A	N/A
Hose, N/A	Pump to Room 3	N/A	Gray	N/A	N/A
Hose, N/A	Pump to Room 4	N/A	Red	N/A	N/A
Hose, N/A	Pump to Generator Slide	N/A	TBD	N/A	N/A
Travel Clamp	Two per Slide	N/A		HWH	N/A
Options					
Kit	(Items listed below)	1		8253	
Jack	12,000 lbs, 16" Stroke	4		7214	
Control Panel	Located to the right of the drivers seat	1		2057	
Level Sensor	Attached to bottom of structure	1		7196	
Hose, 126	Pump to Jack, Left Front	1	Brown	7246	
Hose, 256	Pump to Jack, Left Rear	1	Orange	7249	
Hose, 162	Pump to Jack, Right Front	1	White	7250	
Hose, 269	Pump to Jack, Right Rear	2	Yellow	7252	
Revisions					

8251-LEVELING SYS-FULL AUTO(JACKS ONLY)

PART NO.	DESCRIPTION	QUAN
1124	#4 JIC X #4 O-RING MALE 90	4
1403	RESTRICTOR FITTING #6 X #4	4
2057	CONTROL PANEL AUTO LEVEL PS M894-02-60	1
6569	HARNESS, FOUR WINDS MOTOR HOME 35'	1
7196	AUTO LEVEL SENSOR ASSEMBLY	1
7214	MH 16 SL LEG	4
7239	PUMP & MAN 4 FUN. 3.7 MAN P.S.	1
7247	HOSE KIT-PUMP TO L/F JACK-300" FM-3676-B	1
7248	HOSE KIT-PUMP TO L/R JACK-100" FM-3676-C	1
7251	HOSE KIT-PUMP TO R/F JACK-269" FM-3676-F	1
7253	HOSE KIT-PUMP TO R/R JACK-60" FM-3676-H	1

8250-SLIDE SYSTEM (1 ROOM) FM-3677 (SUGGESTED-SINGLE SLIDE PUMP KIT)

PART NO.	DESCRIPTION	QUAN
6569	HARNESS, FOUR WINDS MOTOR HOME 35'	1
7242	PUMP & MAN 5 FUNC 3.7 MAN P.S.	1
7254	HOSE KIT-PUMP TO SLIDE-84" FM-3676-I	1

8253-LEVELING SYS-FULL AUTO (JACKS & 1 ROOM) FM-3680

PART NO.	DESCRIPTION	QUAN
1124	#4 JIC X #4 O-RING MALE 90	4
1403	RESTRICTOR FITTING #6 X #4	4
2057	CONTROL PANEL AUTO LEVEL PS M894-02-60	1
7196	AUTO LEVEL SENSOR ASSEMBLY	1
7214	MH 16 SL LEG	4
7246	HOSE KIT-PUMP TO L/F JACK-126" FM-3676-A	1
7249	HOSE KIT-PUMP TO L/R JACK-223" FM-3676-D	1
7250	HOSE KIT-PUMP TO R/F JACK-162" FM-3676-E	1
7252	HOSE KIT-PUMP TO R/R JACK-269" FM-3676-G	1

7164-SLIDE ASSEMBLY 36" FM-3655

<u>7000</u>	<u>2000</u>	<u>LENGTH</u>	<u>FITTINGS</u>	<u>COLOR</u>	
7310	2289	024"	SXS	GREEN SOLID	?
	2290	024"	SXS	GREEN STRIPE	?
7331	2342	024"	SXS	RED SOLID	?
	2343	024"	SXS	RED STRIPE	?
7298	2241	032"	SXS	GREEN SOLID	
	2242	032"	SXS	GREEN STRIPE	
7306	2281	048"	SXS	GREEN SOLID	
	2282	048"	SXS	GREEN STRIPE	
7253	2189	060"	SXS	YELLOW SOLID	
	2190	060"	SXS	YELLOW STRIPE	
7254	2191	084"	SXS	GREEN SOLID	
	2192	084"	SXS	GREEN STRIPE	
7287	2221	084"	SXS	BROWN SOLID	
	2222	084"	SXS	BROWN STRIPE	
7248	2187	100"	SXS	ORANGE SOLID	
	2188	100"	SXS	ORANGE STRIPE	
7288	2223	100"	SXS	WHITE SOLID	
	2224	100"	SXS	WHITE STRIPE	
7299	2243	110"	SXS	GRAY SOLID	
	2244	110"	SXS	GRAY STRIPE	
7328	2338	110"	SX90	RED SOLID	
	2339	110"	SX90	RED STRIPE	
KIT	2392	110"	SX90	GREEN SOLID	
	2392	110"	SX90	GREEN STRIPE	
7246	2193	126"	SXS	BROWN SOLID	
	2194	126"	SXS	BROWN STRIPE	
7305	2263	126"	SXS	YELLOW SOLID	
	2264	126"	SXS	YELLOW STRIPE	
7308	2285	140"	SXS	WHITE SOLID	
	2286	140"	SXS	WHITE STRIPE	
7311	2291	140"	SX90	GREEN SOLID	
	2292	140"	SX90	GREEN STRIPE	
7294	2233	140"	SXS	BROWN SOLID	
	2234	140"	SXS	BROWN STRIPE	
KIT	2426	140"	SX90	RED SOLID	
	2426	140"	SX90	RED STRIPE	
7320	2322	160"	SXS	BROWN SOLID	
	2323	160"	SXS	BROWN STRIPE	
7250	2195	162"	SXS	WHITE SOLID	
	2196	162"	SXS	WHITE STRIPE	
KIT	2415	170"	SX90	GREEN SOLID	
	2415	170"	SX90	GREEN STRIPE	
KIT	2425	170"	SX90	RED SOLID	
	2425	170"	SX90	RED STRIPE	
7296	2237	180"	SXS	WHITE SOLID	
	2238	180"	SXS	WHITE STRIPE	
7333	2346	180"	SX90	RED SOLID	?
	2347	180"	SX90	RED STRIPE	?
7340	2361	180"	SX90	GREEN SOLID	?
	2362	180"	SX90	GREEN STRIPE	?
7315	2299	200"	SX90	RED SOLID	
	2300	200"	SX90	RED STRIPE	

<u>7000</u>	<u>2000</u>	<u>LENGTH</u>	<u>FITTINGS</u>	<u>COLOR</u>	
7321	2324	200"	SXS	WHITE SOLID	
	2325	200"	SXS	WHITE STRIPE	
7336	2353	220"	SX90	RED SOLID	
	2354	220"	SX90	RED STRIPE	
7289	2225	223"	SXS	YELLOW SOLID	
	2226	223"	SXS	YELLOW STRIPE	
7295	2235	240"	SXS	ORANGE SOLID	
	2236	240"	SXS	ORANGE STRIPE	
7312	2293	256"	SX90	GREEN SOLID	
	2294	256"	SX90	GREEN STRIPE	
7249	2197	256"	SXS	ORANGE SOLID	
	2198	256"	SXS	ORANGE STRIPE	
7322	2326	264"	SXS	ORANGE SOLID	
	2327	264"	SXS	ORANGE STRIPE	
7251	2185	269"	SXS	WHITE SOLID	
	2186	269"	SXS	WHITE STRIPE	
7252	2199	269"	SXS	YELLOW SOLID	
	2200	269"	SXS	YELLOW STRIPE	
7297	2239	280"	SXS	YELLOW SOLID	
	2240	280"	SXS	YELLOW STRIPE	
7332	2344	280"	SX90	RED SOLID	?
	2345	280"	SX90	RED STRIPE	?
7339	2359	280"	SX90	GREEN SOLID	?
	2360	280"	SX90	GREEN STRIPE	?
7325	2332	282"	SXS	ORANGE SOLID	
	2333	282"	SXS	ORANGE STRIPE	
7247	2183	300"	SXS	BROWN SOLID	
	2184	300"	SXS	BROWN STRIPE	
7304	2265	300"	SXS	WHITE SOLID	
	2266	300"	SXS	WHITE STRIPE	
7323	2328	300"	SXS	YELLOW SOLID	
	2329	300"	SXS	YELLOW STRIPE	
7326	2334	318"	SXS	YELLOW SOLID	
	2335	318"	SXS	YELLOW STRIPE	
7307	2283	364"	SXS	ORANGE SOLID	
	2284	364"	SXS	ORANGE STRIPE	
7309	2287	364"	SXS	YELLOW SOLID	
	2288	364"	SXS	YELLOW STRIPE	
7300	2245	364"	SXS	PURPLE SOLID	
	2246	364"	SXS	PURPLE STRIPE	
7324	2330	364"	SX90	GRAY SOLID	
	2331	364"	SX90	GRAY STRIPE	
7327	2336	396"	SX90	GRAY SOLID	
	2337	396"	SX90	GRAY STRIPE	
7341	2363	396"	SXS	YELLOW SOLID	
	2364	396"	SXS	YELLOW STRIPE	
7342	2365	396"	SXS	ORANGE SOLID	
	2366	396"	SXS	ORANGE STRIPE	
7313	2295	420"	SXS	PURPLE SOLID	
	2296	420"	SXS	PURPLE STRIPE	
7335	2350	425"	SX90	PURPLE SOLID	
	2351	425"	SX90	PURPLE STRIPE	

<u>7000</u>	<u>2000</u>	<u>LENGTH</u>	<u>FITTINGS</u>	<u>COLOR</u>	
7337	2355	425"	SX90	GRAY SOLID	
	2356	425"	SX90	GRAY STRIPE	
7314	2297	450"	SX90	GRAY SOLID	
	2298	450"	SX90	GRAY STRIPE	
7317	2309	450"	SXS	PURPLE SOLID	
	2310	450"	SXS	PURPLE STRIPE	
7334	2348	475"	SXS	GRAY SOLID	
	2349	475"	SXS	GRAY STRIPE	
7338	2357	475"	SXS	PURPLE SOLID	
	2358	475"	SXS	PURPLE STRIPE	