



# **AJ DUAL LEG**

## **Installation/Operation/Warranty Guide**

Effective October 2010

**EQ009R6**



(800) 846-9659  
EQSystems.us

## AJ SERIES

### Dual Leg Hydraulic Jacks: 15,000 lb.Capacity, 24” Stroke

## INSTALLATION

### Tools Required for Installation

- Ratchet, sockets and wrench set
- Wire cutters/crimpers
- Electric drill and bits
- Screw gun bit
- Welding equipment (if welding leg in place)

### Additional Parts Needed for Installation

- # 6 gauge power wire (to connect battery +12V to the pump)
- # 6 gauge ground wire (to connect battery – 12V ground to pump)
- # 6 gauge ring terminals
- Loom clips (to secure switch and harness to the trailer)
- Self tapping screws or pop rivets (to secure loom clips)
- Wire ties
- Automatic transmission fluid (multi purpose or Dexron) (aprox 6 qts)  
to fill the resivior and system

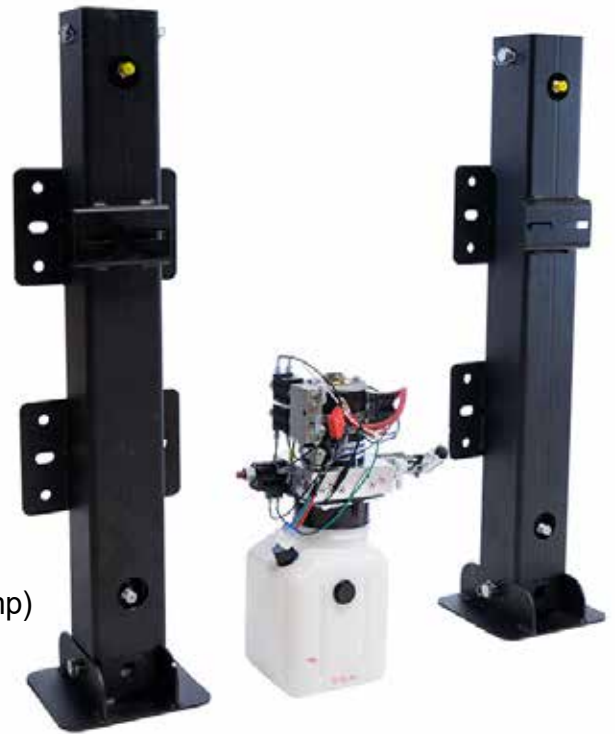

## JACK MOUNTING

The AJ style jacks are available in “bolt on” or “weld on” configurations (depending on the mounting option ordered for the system). Mounting provisions must be designed with adequate strength to sustain trailer weight and jack lifting capacity. If bolting the jack in place, ensure the use of appropriate size for the application ( $\frac{1}{2}$ ” or  $\frac{3}{8}$ ”) and quantity of mounting hardware. The use of Grade 8 bolts is recommended. Welding the jack in place requires sound welding practices.

The jacks should be mounted so that when the trailer is level (while mounted to the tow vehicle) there is a Minimum of 10 inches of Ground Clearance. This is usually achieved by mounting the jacks so that the foot is slightly below the bottom edge of trailer. The bottom of the footpads should not be lower than any other item mounted on the trailer.

## PUMP MOUNTING

The pump is mounted with threaded studs that are fitted to the pump body. Flange nuts are provided. The pump is designed to be mounted vertically only.

## SWITCH HARNESS AND HYDRAULIC LINES

The AJ jack has been shipped with all necessary switchgear, harnesses and hydraulic lines. These items are specifically engineered to operate your system and should not be altered in any manner. Modification of any factory-supplied item may result in the denial of all warranty claims.

## SWITCHGEAR

The unit may have been provided with a key switch in the switchgear box (depending on the option ordered). If unit is not supplied with a key switch, the +12v battery lead must be fed through a power disconnect switch to fully isolate the system during travel or inactivity. Minimum switch rating must be 80 ampere DC. Switchgear is plugged into the system harness through a weather resistant connector (shown in Fig.1)

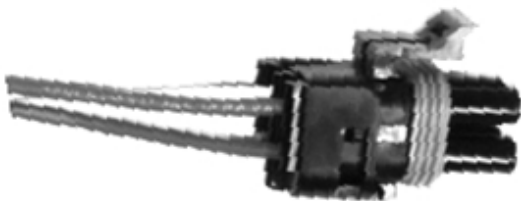

**Fig.1- Weather Resistant Connector**

# BATTERY CONNECTIONS

**Battery Lead (+12volts):** Attach a # 6-gauge (minimum) wire between the positive +12 volt terminal on the battery and the plus ( + ) terminal on the motor contactor; shown in Fig 2. There is a small red wire on this terminal.

If circuit protection is required, install an 80 amp (minimum) circuit breaker.

Fig. 2

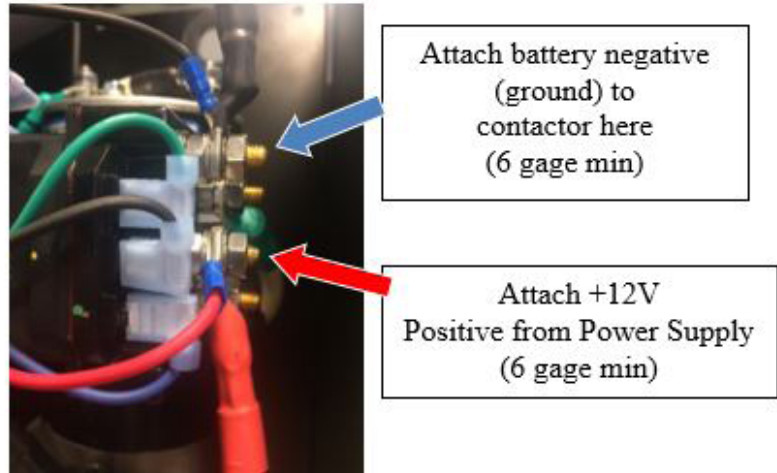

**Pump Ground** Attach a # 6 gauge (minimum) wire between the negative -12 volt terminal on the battery and the negative terminal on the contactor as shown in Fig.2. These units will not ground thru the mounting. The decribed ground/negative battery to contactor connection must be made.

## Reversing Contactor Wiring Pump 3041 and 3201

**Note:** on pump # 3201KS the Blue and green wires are reversed

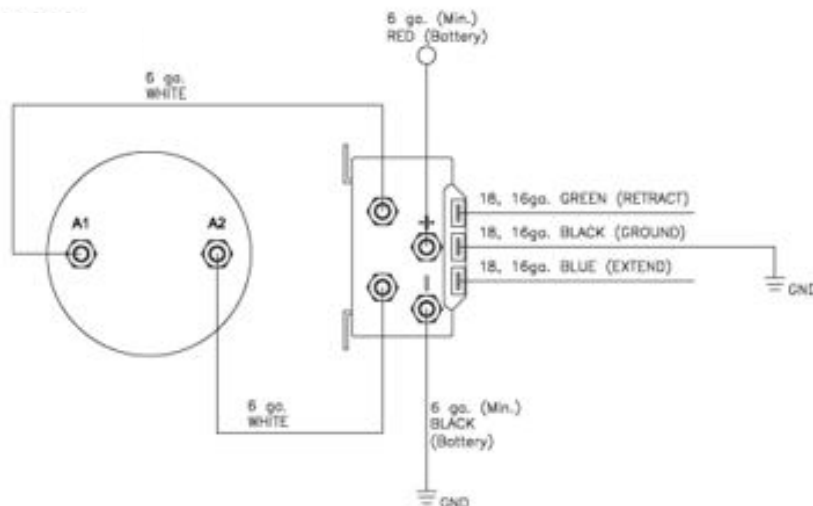



# HYDRAULIC HOSE CONNECTIONS

## **Connections to Top/ Extend Jack Port:**

If equipped with a manual selector valve:

The extend port on the pump is fitted with a manual selector valve extending from the manifold block. The Selector Valve has Twist Turn Knobs to select jack operation. The hoses are to be connected from the selector valve to the top fittings (cap or closed end) of each jack leg.

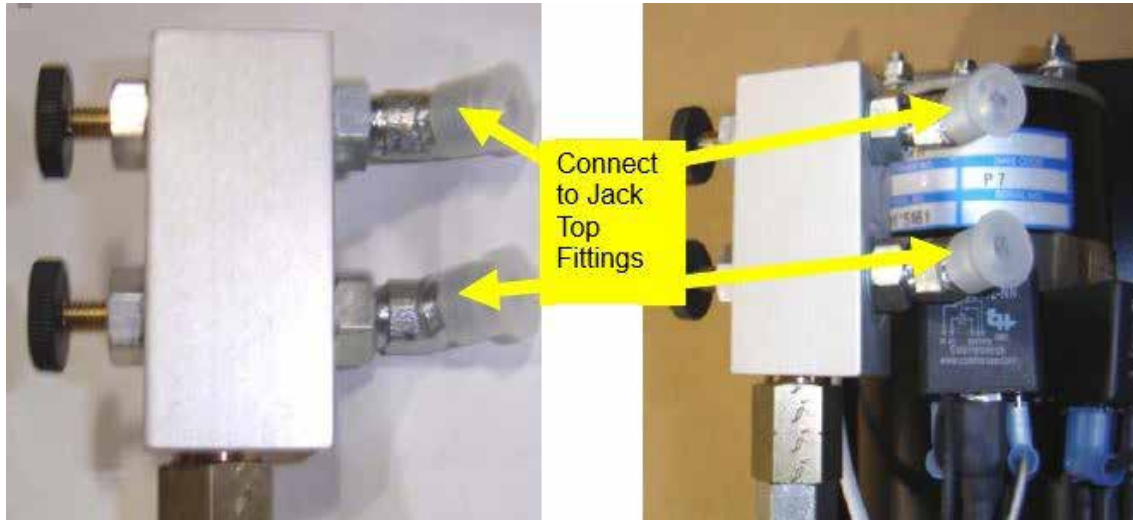

## **If not equipped with manual selector valve:**

The extend port on the pump is fitted dual connection assembly (see below). Hoses are routed from this assembly to the top fitting (cap or closed end) of each jackleg. The port is marked with a “T” or “A” near the reservoir.



## **Hose Connections Bottom/ Retract Jack Port:**

The pump retracts port is equipped with a TEE fitting. The port is marked with a “B” near the reservoir. This fitting is connected to the bottom fitting of each jack (rod end). It does not matter which one is left or right.

# SYSTEM PURGING

Following component installation, this procedure must be performed with the initial running of hydraulic system. All electrical and hose connections must be completed before the purging process.

- 1) Fill the reservoir with Dexron Automatic Transmission Fluid.
- 2) Make sure the manual selector valves (black trumpet valves), if equipped, are fully pushed in to the IN/OPEN position to allow proper fluid flow.
- 3) Remove the Bottom (Retract) hoses from the TEE fitting at the pump and place them into a clean container. Cap the ends of the TEE fitting on the pump to ensure that no air or debris can enter.
- 4) With the Bottom hoses placed in a container, run the pump to fully EXTEND the jacks(s). Maintain the fluid level in the reservoir approx  $\frac{1}{2}$  full. Do not allow reservoir to run empty. If jacks(s) will not fully extend, crack loose the upper hose(s) at the jack(s) and run pump to extend until all the air is expelled. Retighten the hoses and complete the extension of the jack(s).  
Continue to maintain the fluid level in reservoir at  $\frac{1}{2}$  full. Note: normally only air will be expelled from the disconnected bottom hoses, however, it is possible some residual oil will be expelled.
- 5) Reconnect the Bottom (Retract) hoses to the Tee fitting at the pump.
- 6) Run the pump to RETRACT the jack(s). Maintain the fluid level in reservoir at  $\frac{3}{4}$  full. Do not fill to full until after the legs are fully retracted.
- 7) If fluid in reservoir appears to be aerated (foaming), allow unit to sit until foam dissipates (approx 5- 10 minutes).
- 8) Fully extend and retract jack leg(s) a minimum of 3 times. Allow the air in the foamed oil to dissipate as needed. Maintain the fluid level in the reservoir as needed.

# RESERVOIR BREATHER CAP

Once the system is purged, install the fill/breather cap. Failure to do so will allow unwanted debris or water into the system.

**Fluid Level:** When the jack is fully retracted, the fluid level in the reservoir should be approximately one inch below the fill cap. If fluid needs to be added, use Dexron III automatic transmission fluid (the same as used for a GM automobile).

# OPERATION

To raise and lower the jacks, activate the keyed switch (if equipped), then push and hold the rocker switch in the up or down position. TRAILER UP to extend the jacks or TRAILER DOWN to retract. If the system is equipped with a manual selector valve:

1. Twisting the knob counter clockwise to opens the valve for the desired jack operation. By turning both knobs out (counter clockwise), the jacks will operate in tandem. To operate only one jack, close the valve (turn it fully clockwise) to the jack that is to remain stationary.
2. Operate the switch in the desired direction. Trailer up to extend jacks or trailer down to retract jacks.
3. Twist the valve knobs to the IN/Closed (clockwise) position for storage or travel.

When finished, remove the key or operate the manual disconnect to prepare the system for travel.

The jack will “hold” a position by releasing the switch at any time. There is no need to take the “weight” off the jack when storing the trailer. Positive check valves in the system will not allow the jack to “bleed down”.

**Warning: With any hydraulic application, holding any position on a cylinder must be done with safety in mind. Failure in the system may cause the leg to retract or extend on its own. When working under or near the trailer, always use jack stands of appropriate rating to support the weight of the trailer.**

The keyed switch must be in the off position and the key must be removed when the jack is not in use and/or when the trailer is in transit. If unit is not supplied with a keyed switch, the +12v battery lead must be fed through a power disconnect switch to fully isolate the system during inactivity or travel. The minimum disconnect switch rating must be 80 ampere DC.

# MANUAL OVERRIDE

The AJ series single jack has provisions for manual override. The following procedure gives systematic instructions on how to operate the manual override to either retract or extend the jacks.

## Required Items:

- Reversible Drill- capable of producing a minimum of 2000 r.p.m. for the pump to develop appropriate pressure output.
- 6mm (1/4") Hex Key (Allen wrench) bit or driver

The hydraulic power unit is equipped with a manual override output shaft. The override shaft is located on the top of the motor in the center under a foil seal.

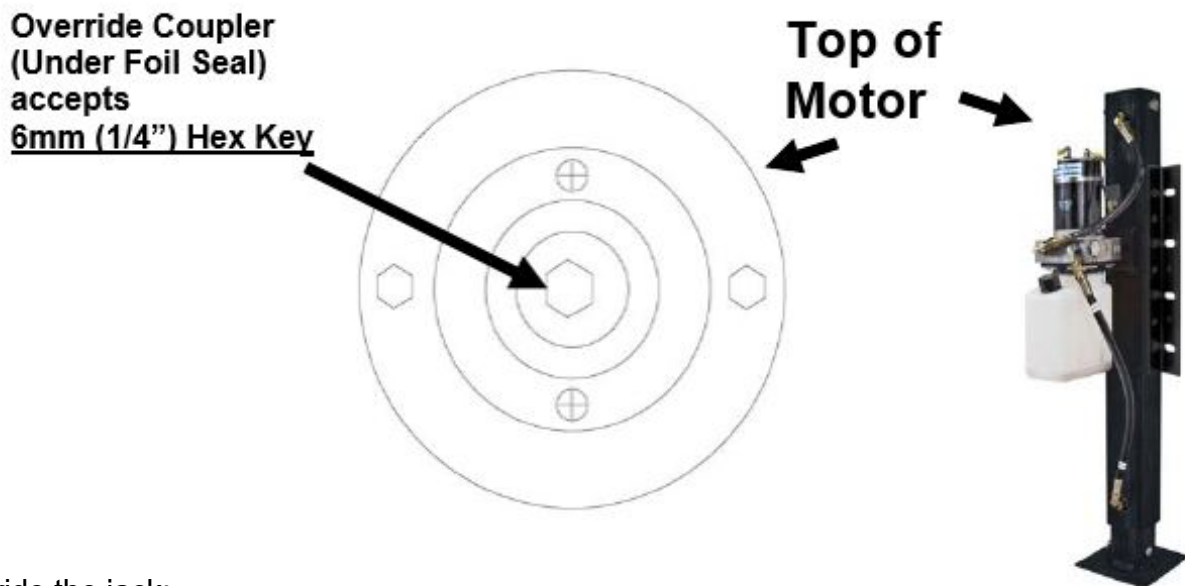

To override the jack:

Remove the foil seal from the top of the motor. Use a small flat head screwdriver if necessary.

Insert the 6mm (1/4") hex key (Allen) bit on the manual override shaft located at the top of the motor.

To Retract:

Run drill in the clockwise direction at 2000 r.p.m. (minimum). The jack will retract.

To Extend:

Run drill in the counterclockwise direction at 2000 r.p.m. (minimum). The jack will extend.



# PROBLEM SOLVING

**“The jack runs for a few seconds, then stops”** The battery is weak or battery capacity is diminished. Charge the battery fully. It may be necessary to “load test” the battery.

**“The jack only runs in one direction”** Verify appropriate battery voltage. Verify that all wires are attached appropriately. Verify proper function of the switchgear.

**“I push the switch and nothing happens”** Ensure both positive and negative -12V have adequate connection. Ensure full charge on your battery. The vast majority of calls to the EQ Systems Help Desk are related to low battery voltage. Ensure that the unit is properly grounded to the battery with a minimum # 6-gauge wire. Check all associated wiring.

**“The jack is jerky when retracting”** This may be caused by air in the system, low fluid level, or incorrect hose installation. To purge leg, add fluid as necessary and run the leg to full extension and retraction at least twice. If problem persists, call EQ Systems for assistance.

**Fluid Level:** When the jack is fully retracted, the fluid level in the reservoir should be approximately one inch below the fill cap. If fluid needs to be added, use Dexron III automatic transmission fluid (the same as used for a GM automobile).