



**EQ SMART-LEVEL  
FORD TRANSIT CHASSIS  
Installation/Operation/Warranty Guide**

Effective July 2024

EQ025



(800) 846-9659  
EQSystems.us

# EQ Smart-Level Ford Transit Chassis Installation/Operation/Warranty Guide

Effective July 2024

## **Contents**

<b><u>Required Tools &amp; Parts</u></b>	<b><u>Page 3</u></b>
<b><u>Jacks</u></b>	<b><u>Page 4</u></b>
<b><u>Foot Installation For SL 13 Jack Leg Assemblies</u></b>	<b><u>Page 5</u></b>
<b><u>Pump/Fittings/Hoses</u></b>	<b><u>Page 6</u></b>
<b><u>Wire Harness/Install Control Panel</u></b>	<b><u>Page 7</u></b>
<b><u>Chassis Interface Connection</u></b>	<b><u>Page 8</u></b>
<b><u>Power Connections/Purging</u></b>	<b><u>Page 9</u></b>
<b><u>Additional Info On Power Supply Connections</u></b>	<b><u>Page 10</u></b>
<b><u>Control Panel Programing</u></b>	<b><u>Page 11</u></b>
<b><u>Operation &amp; Setting the Null</u></b>	<b><u>Pages 12 - 14</u></b>
<b><u>EQ Smart-Level Bluetooth Operation</u></b>	<b><u>Page 14</u></b>
<b><u>Panel Indicators</u></b>	<b><u>Page 15</u></b>
<b><u>Manual Override</u></b>	<b><u>Page 16</u></b>
<b><u>Diagrams</u></b>	<b><u>Pages 17 - 24</u></b>
<b><u>Torque Specifications</u></b>	<b><u>Pages 25 - 26</u></b>
<b><u>Warranty</u></b>	<b><u>Page 27</u></b>

This manual is intended to be used by technicians installing EQ Smart-Level systems. It is assumed that the reader is familiar with hydraulic, mechanical, and electrical systems; in addition to workplace safety.

# REQUIRED TOOLS AND PARTS

## **Tools Required for Installation**

- Ratchet, sockets and wrench set
- Wire cutters/crimpers
- 2000 r.p.m. electric drill/screw gun and bits

---

## **Additional Items Required for Installation**

\*\*The following cables, connectors and breakers can be purchased from EQ Systems – Part # 70103

- #6 AWG power wire \*\*(to connect battery + 12V positive to the pump) \*
- #6 AWG ground wire \*\*(to connect battery - 12V ground to pump) \*
- #6 AWG ring terminals \*\*
- 100-amp resettable breaker (if required) \*\*
- Loom clips (to secure harness and hydraulic hoses to the coach)
- Self-drilling screws or pop rivets
- Wire ties
- 8 – 10 quarts Automatic Transmission Fluid (Dexron or multi-purpose)

**\*Note:** These items must be #4 AWG or larger if cable run is greater than 12 ft

**Note: Modification of any factory supplied item may result in the denial of all warranty claims.  
Call EQSystems Technical Support prior to any modifications**

**With any hydraulic application, holding position on a cylinder must be done with safety in mind. Failure in the system may cause the jacks to retract or extend suddenly. When working under or near the coach, always use jack stands of appropriate rating to support the weight of the coach.**

# JACKS

Determine where the jacks will be mounted. The jacks must be mounted to the chassis frame, as close as possible to the front and rear axles.

Secure the jack brackets in place according to the bracket mounting drawings. Bolt the jack to the bracket using the supplied nuts and washers. The jacks must be installed with a minimum of 6 inches of ground clearance. See Installation chart below. In any case, the bottom of the footpad should be no lower than any other item mounted on the coach. Pay particular attention to the angle of departure for the chassis when mounting the rear jacks – and the angle of approach when mounting the front jacks.

## Reference Chart for Installing Jacks

The foot/pad must be mounted with-in the range suggested (see chart below) for proper operation of the system. Retract the jack fully (jack up). Ground clearance is determined by measuring from the bottom of the jack foot to the ground (jack retracted fully). When in doubt call EQ Systems 800-846-9659 ext. 3391

**6 to 7 inches of ground clearance required**

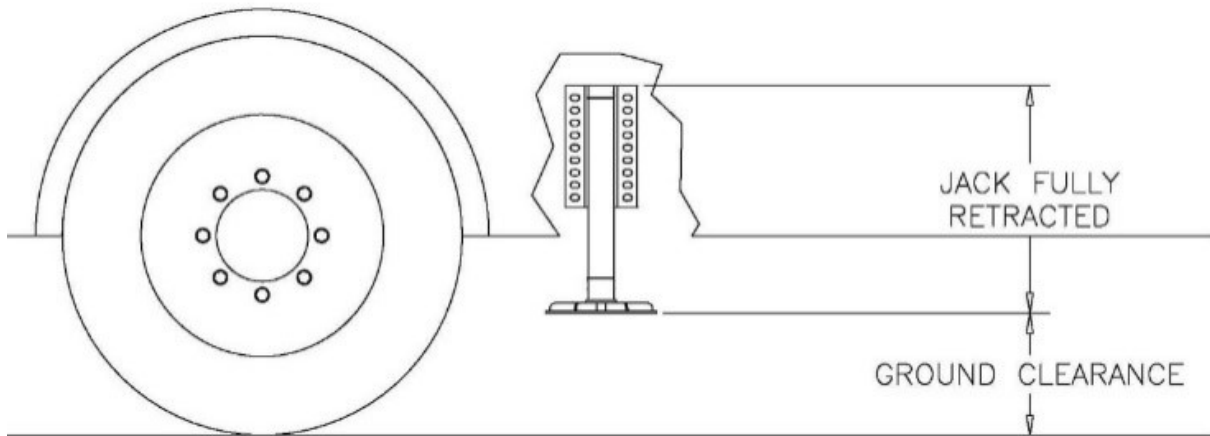

**If there are any questions, please call EQ Systems (800) 846-9659.**

# FOOT INSTALLATION FOR SL 13 JACK LEG ASSEMBLIES

## SL 13 Leg Assembly

This assembly uses the 3/4"-16 nylock jam nut.

Required for installation:

- 1/2" drive Impact wrench/gun
- 1/2" drive X 1 1/16" socket (6 point preferred)

## Process

1. Check/verify that the threads on the end of the cylinder rod are clean and not damaged. Use the nylock nut to check that it will thread (start) on the end of the rod. Do not fully install or tighten at this time. Remove the nut.
2. Position the hole in the middle of the foot pad over the threaded end of the rod. Start the nylock nut onto the threads by hand.
3. Using the impact wrench/gun and the 1 1/16" socket, tighten the nut onto the rod. Note that the rod may rotate as you are doing this. Tighten the nut until between 1 and 3 threads are visible past the end of the nylock nut.

## Notes

- When properly installed, if the cylinder is extended slightly, the foot should pivot slightly and will be free to rotate.

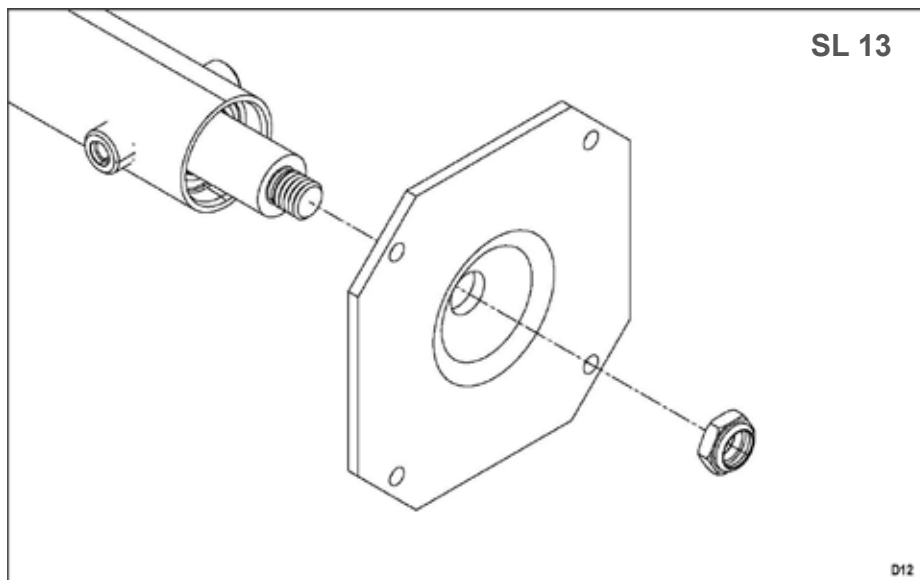

# PUMP

Install the pump kit on the coach. The pump must be mounted in a location that is reasonable to route all of the hydraulic hoses to the manifold. It must be accessible for filling the reservoir and monitoring the fill level. The cartridge valves and the end of the motor must be accessible to manual override the system (see instructions for manual override).

---

# FITTINGS

Install the hydraulic adaptor fittings in the top and bottom of each jack and install the fittings into the manifold. The straight thread O-ring side always goes to the cylinder or manifold. The tapered side will get the hose attached to it. When installing straight fittings into the leg or manifold, tighten to 15 lbs.-ft. When using 90-degree fittings, turn until finger tight, position correctly, then tighten the jam nut to 15 lbs.-ft.

---

# HOSE

Install the hydraulic hoses according to the chart.

- Route the hoses clear of all hot exhaust components and pinch points in the suspension/chassis system. (moving objects, sharp edges and high heat sources)
- Attach the hoses to the manifold and jack fittings.
- Tighten to 15 lbs.-ft. Secure the hydraulic hoses with wire ties or loom clamps to the chassis.
- Care should be taken to not kink or twist hoses.
- The min. bend radius is 6 inches.

## **Installation of Hoses to the Manifold**

### **Jack Leg**

### **Manifold Connection**

Left Front - Top

Brown Solid (T-1)

Left Front - Bottom

Brown Stripe (B-1)

Right Front - Top

White Solid (T-2)

Right Front - Bottom

White Stripe (B-2)

Left Rear - Top

Orange Solid (T-3)

Left Rear - Bottom

Orange Stripe (B-3)

Right Rear - Top

Yellow Solid (T-4)

Right Rear - Bottom

Yellow Stripe (B-4)

## WIRE HARNESS

Route the wire harness from the pump assembly to the area where the control panel is to be mounted.

- The harness needs to be routed away from moving objects, sharp edges, and high heat sources.
- Use wire ties and/or loom clamps to secure in place.
- The end with the 9-pin and 2-pin connector goes to the pump assembly. (See the drawing for the layout.)
- Connect the harness connectors to the matching connectors at the pump assembly.

## EQ SMART-LEVEL CONTROL PANEL

Fasten control panel (vertically or horizontally) in desired location.

- It may not function well right at 45 degrees. The most accurate will be right at horizontal (0 degrees) or vertical (90 degrees).
- It may be mounted on any surface regardless of its orientation to the front of the vehicle  
*Examples:* on the center console, vertical wall, cabinet wall or other firm structure.

- 
- The control panel is not waterproof therefore it must be in an interior location or compartment protected from the elements and spill areas.
  - Attach the supplied wire harness between the Control Panel and the location of the pump assembly.
  - There are two connectors, one is a 12-pin double row and the other is a 3-pin, which is the power and ground feed for the control panel.
  - There may be additional optional connectors that are not used for most installations. There may be additional wires breaking out of this harness, they are discussed on page 10 in chassis interface.
  - The control panel must be firmly mounted to a surface that 'reacts' with the coach during leveling. The Auto Level function requires this as the leveling sensors are located inside of the control panel. Also, a set up process known as Orientation Program followed by setting the null (described later) must be performed. If these steps are not properly completed the Auto Level function will not operate properly. See orientation setting and null setting for these processes.

# CHASSIS INTERFACE CONNECTIONS

Please note that Step 1 and 2 are required on motorized units.  
Step 3 is optional.

## Step 1 - Keypad Ignition Disable Circuit

- Note the “break-outs” near the end of the keypad harness. The Pink wire must receive a +12 VDC Input when the ignition key is in the “on” position.
- Connect this wire to the ignition positive. This will make the wire “hot” and will prevent jack extension when the vehicle ignition key is in the on (engine run) position. This also provides for a “jacks down” warning in the event of a jack drifting from the stowed position during travel. This connection is required.
- Failure to make this connection may create an unsafe condition and may void the warranty (on motorized units).

## Step 2 - The Black/Yellow Wire Must Receive a Ground Input

- This black/yellow wire must be connected to a chassis ground.
- If this wire is not connected to ground, the Engage Park Brake light will be on and Auto Level may be Denied.

## Step 3 - Optional Park Brake Connection for Black/Yellow Wire

Contact your chassis manufacturer to verify park brake chassis connection and location. This connection must be done by a technician qualified for chassis electrical systems.

- Most chassis manufacturers are now doing this through the Dash Module. Attempts to connect this improperly could lead to dash feedback or other issues.
- This connection to a park brake signal is optional. If this input is not connected to the park brake signal or to ground, Auto Level may be denied.
- Also, the engage park brake light will be on if the panel is powered up or the key is in the on (engine run position).

\*Note on items 1 and 2: If Black/Yellow is connected to a park brake signal (as in step 2) and the pink is connected (required) as in Step 1, an automatic “all retract” will be initiated if the key is turned on (engine run position) and the park brake is released.



# BI-ROTATIONAL MOTOR PUMP #3195 AND #3195KS

## Power Connections

Attach a # 6 gauge wire (# 4 gauge if the run is over 12ft.) from the **positive** +12V terminal on the battery to the + terminal on the motor solenoid. There will be a yellow fused wire on this terminal.

- This supply may be fused at the source with 100-amp circuit breaker.
- This +12v supply must be a dedicated and isolated circuit (not shared with other devices), and must be constant, non-switched +12vdc.

Attach a # 6 gauge wire (# 4 gauge if the run is over 12ft.) between the **negative** -12v terminal on the battery and the ground stud on the pump.

- This is the preferred method of grounding. If grounding the pump to the chassis, the connection must be sound, free of paint and not susceptible to corrosion.
- The battery must be connected to the frame with # 4 gauge or larger wire. It is not acceptable to allow the pump mounting bolts to be the sole grounding connection.

## PURGING/FILLING WITH FLUID

### **PURGING BI-ROTATIONAL PUMP #S 3195KS AND 2542KS**

**You must follow this procedure strictly. Any deviation from the process will cause the purging process to become difficult and time consuming.**

1. Fill pump reservoir to full approx. 1 to 1 ½ inch from top with automatic transmission fluid, the multipurpose or any of the Dexron/Mercon fluids will work.
2. Using the manual switch for the front jacks extend the front jacks until they make ground contact. Do not lift the vehicle. If the vehicle is on a lift the jacks may be fully extended.  
Note: extend is the arrow pointing down.
3. Press all retract switch. After the front jacks have fully retracted and the pump shuts off check the reservoir fluid. Refill to full approx. 1 to 1 ½ inch from top.
4. If the fluid in the reservoir is aerated or foamed up, allow time for foam/air to dissipate before continuing. Allow 10 minutes for foam and air to dissipate.
5. Using the manual switch for the rear jacks extend the rear jacks until they make ground contact. Do not lift the vehicle. If the vehicle is on a lift the jacks may be fully extended.
6. Press all retract switch. After the rear jacks have fully retracted and the pump shuts off check the reservoir fluid. Refill to full approx. 1 to 1 ½ inch from top.
7. If the fluid in the reservoir is aerated or foamed up, allow time for foam/air to dissipate before continuing. Allow 10 minutes for foam and air to dissipate.
8. Using manual switches extend to full extension of front and rear jacks. At this point jacks may be allowed to lift the vehicle. Allow 10 minutes for foam and air to dissipate.
9. Press all retract switch. After the jacks have fully retracted and the pump shuts off check the reservoir fluid. Refill to full approx. 1 to 1 ½ inch from top. Allow 10 minutes for foam and air to dissipate
10. Check fluid level. Fill to full 1 to 1 ½ inch from top.
11. Repeat steps 7 through 10.

**The above purging process is for dealers and retail installation. High volume OEM installers may have special procedures utilizing special equipment. Call EQ Systems for assistance.**

Note: All wire gauge sizes and breaker ratings noted are the recommended size. Larger gauge wiring and higher breaker rating may be used. There may be variances on specific systems supplied to OEM customers due to the exact makeup of the system.

## Additional information on Power Supply connections

The below is just general information to be used as a guide.

Pump #'s	Recommended Min Wire Gauge Size	Circuit Breaker	Normal Pump Amperage
3195KS, 3195, 3043	4 or 6 Gauge	100	40 - 100
2542KS, 2532, 2542	2 or 4 Gauge	150	60 - 140
3218	2 or 4 Gauge	150	60 - 140
1551	2 or 4 Gauge	150	60 - 150

## Battery Size Considerations

Generally, the greater the size of the battery or bank the better. A group 24 RV deep cycle marine battery should be considered the minimum.

Multiple batteries connected in parallel is common. The battery or bank should have some sort of charging system in place to keep the battery or bank at peak charge for proper operation.

## Circuit Breakers

The breaker should be of the manual reset type that is typical of the RV/Marine industries usage. This should be of the “slow blow or trip type” to avoid nuisance tripping due to current surges common to the hydraulic pump motor start up. These surges may be many times the normal pump amperage generally lasting only milliseconds.

**Note:** if a fuse is used in lieu of a breaker, a “slow blow” type of higher amperage rating is recommended to prevent nuisance “blowing” of the fuse.

The purpose of the breaker is to provide protection against shorting to ground of the positive feed to the pump assembly. It is not needed for system overload protection which is provided by the hydraulic systems relief circuit.

## Battery Type and Size

A minimum group 24 RV/marine type battery is recommended. Battery rating should be a minimum 100 RC (Reserve capacity) with a 500 CCA (Cold Cranking Amperage). The higher these numbers the better. Common types are flooded lead acid, Gel and AGM (Absorbed Glass Mat).

**Note:** Some lithium batteries are not suited for this application. As they cannot provide the high running amperage and surges. Check with the battery supplier/manufacture for info on this.

## Additional Notes on Wiring

There may be additional wiring at the pump or near the control panel for specific OEM requirements. Check with EQ Systems on the usage of these if present.

# EQ SMART-LEVEL CONTROL PANEL PROGRAMING

After the system is fully installed the control panel must be programed for operation. Failure to do this will result in a failed or improper Auto Level. There are two program settings that must be programed in the following order - 1) Orientation and 2) Null.

## Step 1 - Orientation Setting

- This process cannot be completed until after the system has been connected to power and the control panel has been mounted and all electrical harness connections have been completed.
- This process teaches the control panel where the front of the coach is and how the control panel is mounted (vertical or horizontal). If this process is not performed correctly the processor will not know where the front of the coach is.
- It is possible that without doing this process it may work on a level floor/shop environment however when at sites where the system needs to operate specific legs for leveling it very likely will operate the improper legs.
- Once this process is properly completed the setting will be “retained” in the control panel and should not ever need to be performed again unless the control panel is replaced or moved to a different location.
- With the control panel off, press and hold the ALL RETRACT button, then while holding it press the POWER button, then release both buttons. The power light will start blinking and you will hear a rhythm beeping, and the 4 jacks down indicator lights will be on.
- Next the orientation is selected by pressing one of the manual control arrows. The exact specific one is determined by how the panel is mounted (see examples below). You will select an up arrow if the panel is mounted vertically and down arrow if it is mounted horizontal. The specific one is the one that most relates to the front of the coach.

## Examples

- If the panel is mounted vertically in the dash so that you are looking at it when sitting in the driver’s seat. You would push the up arrow for the front jacks.
- If the panel is mounted horizontal and in a side surface next to the drivers left arm, then you would push the down arrow for the right-side jacks.
- If the panel is mounted vertically in a cabinet wall so that when you are looking at it, you are facing the rear of the coach then you would press the up arrow for the rear jacks.

**Note: if you are not clear on this process check our web site for video and/or call EQ Systems for assistance.**

## Step 2 - Setting the Null

Null is the term used to indicate the levelness of the coach. A Null setting should have been performed by the installer. If the coach is not level following an attempt to Auto Level, you will need to level the coach and reset the null.

Use a bubble level on a flat surface in the center of the coach as a reference. You do not need to have the jacks deployed to set the null.

- To set the null, first press the POWER button on the keypad to activate the unit. The LED light next to the POWER button should be lit RED when the power is on.
- Level the coach by deploying jacks manually, or by simply parking the coach on a level site. Once the coach is level, turn the POWER off at the panel.
- While holding down the AUTO LEVEL button, press and release the POWER button. This should cause the keypad to make a series of beeps.
- After the Keypad has beeped 5 to 6 times, release the AUTO LEVEL button and you will get a confirmation beep. (The Keypad will continue to beep if the Auto Level button is held) The new null has been set and the panel will store/remember this setting.
- Press and release the ALL RETRACT button to retract the jacks to the stowed position.

## EQ SMART-LEVEL OPERATION

### Power On:

Push and release the POWER button to engage power.

- The LED light next to the power button should be lit RED when power is on. You will need to have the ignition key in the off position to extend the jacks (most applications).
- If you attempt to manually extend jacks or all jacks with the AUTO LEVEL button, you will hear a deny tone from the keypad if the ignition key is in the on (engine run) position (most applications).
- Also depending on if the park brake disable is connected and the park brake is released you may not be able to extend jacks.

### Auto Level:

- Press the AUTO LEVEL button and release. The system will send out a continuous series of beeps and the “Operating” LED will be on to let you know Auto Level is in operation and will automatically level the coach.
- Do not move around or exit the coach during this operation, doing so will fault out the operation or result in an incomplete leveling/stabilization operation.
- When completed, the Keypad will signal the successful completion with a dual-stage tone. The Keypad may be left on once level has been achieved. The Keypad will enter “sleep mode” after five minutes of inactivity.

**Note:** Auto Level will be denied if the jack indicator lights are on. To clear this press ALL RETRACT, then perform Auto Level.

## Retracting Jacks:

- Use the ALL RETRACT button to retract the jacks prior to travel. This system does provide the ability to retract the jacks using the UP buttons for each pair of jacks. However, these buttons are not intended to be used for retracting the jacks to their stowed position prior to travel. The UP arrows are to be used only for retracting the jacks to help level the coach. The ALL RETRACT button must be pressed to insure the system is ready/safe for travel. All jacks should automatically retract and return to stowed position when the ALL RETRACT button is pressed and released. The pump will run in retract for approximately 5 seconds after the last jack has been fully retracted- or until a time limit of 90 seconds has been reached.

**It is always the responsibility of the coach operator to visually confirm that the jacks are fully retracted and safe for travel.**

## Helpful Hints

- Do not allow motion in the coach during the Auto Level operation (don't move around in the coach). This could cause the system to fault out or level/stabilize improperly.
- The Auto Level is a microprocessor-controlled system. Proper and adequate battery voltage and permanent chassis ground are essential.
- Your system is equipped with override ability. Refer to the procedure for proper use of this. It is usually better to review this procedure prior to its actual use, rather than having to learn a new procedure in difficult environments and or situations. This is designed to get the jacks retracted in the event that there has been a power/control failure.
- If the system has not been used (with the jacks stowed) for over 24 hours, it is recommended that you engage the ALL RETRACT button prior to travel in order to re-pressurize the system.
- A lubricant, like WD40, may be used to clean and lubricate the cylinder shafts.

## Manual Operation

- Push and release the POWER Keypad button to engage power. All lights will come on then most will go out. The LED light next to the POWER button should be lit RED when power is on. You will need to have the ignition key switch in the off position to extend the jacks. If you attempt to extend individual jacks by pressing the DOWN Keypad buttons or all the jacks with the AUTO LEVEL button, you will hear a "deny" tone from the keypad if the ignition key is in the improper position. Also depending on if the park brake disable is connected and the park brake is released you may not be able to extend jacks. (See step 9 on page 5).
- Using the DOWN Keypad button, extend the jacks until they contact the ground (this is referred to as "planting" the jacks). As you extend the jacks, an LED light on the Keypad will indicate the jack(s) is out of the "stowed" position. Jacks may only be operated in pairs using the manual keypad buttons.
- Use a bubble level on a flat surface in the center of the coach. Level the vehicle by using the DOWN or UP Keypad buttons until the vehicle is level. Jacks may be operated only in pairs. The Keypad may be left on or powered off once level has been achieved. The Keypad will enter "sleep mode" after five minutes of inactivity.

- Use the ALL RETRACT button to retract the jacks prior to travel. This system does provide the ability to retract the jacks using the UP buttons for each pair of jacks. However, these buttons are not intended to be used for retracting the jacks to their stowed position prior to travel. The UP arrows are to be used only for retracting the jacks to help level the coach. The ALL RETRACT button must be pressed to insure the system is ready/safe for travel. All jacks should automatically retract and return to stowed position when the ALL RETRACT button is pressed and released. The pump will run in retract for approximately 5 seconds after the last jack has been fully retracted, or until a time limit of 90 seconds has been reached.
- Check/test the following: If you have properly installed the ignition disable circuit, the jacks will not extend if the ignition key is in the on (engine run position). And the ignition on LED should come on. When you turn the key off the LED should go out and allow extension. This is a required connection step. Failure to properly connect this could create an unsafe condition and may void the warranty.

**It is always the responsibility of the coach operator to visually confirm that the jacks are fully retracted and safe for travel.**

## EQ Smart-Level Bluetooth Operation

- If the face of your keypad indicates that your controller is compatible with a Bluetooth device, download EQ Smart-Level in the Android or Apple App Store. When downloading the app, make sure your Bluetooth setting is turned on or the app will not connect to your coach. Once the app is downloaded please follow the instructions to level your coach.
- If your keypad does not indicate compatibility, your Bluetooth connectivity may be through your multiplex system.
- The operation of the system from a smart phone is the same as from the control panel with the exception that you cannot perform the orientation setting or null programing from the Bluetooth.

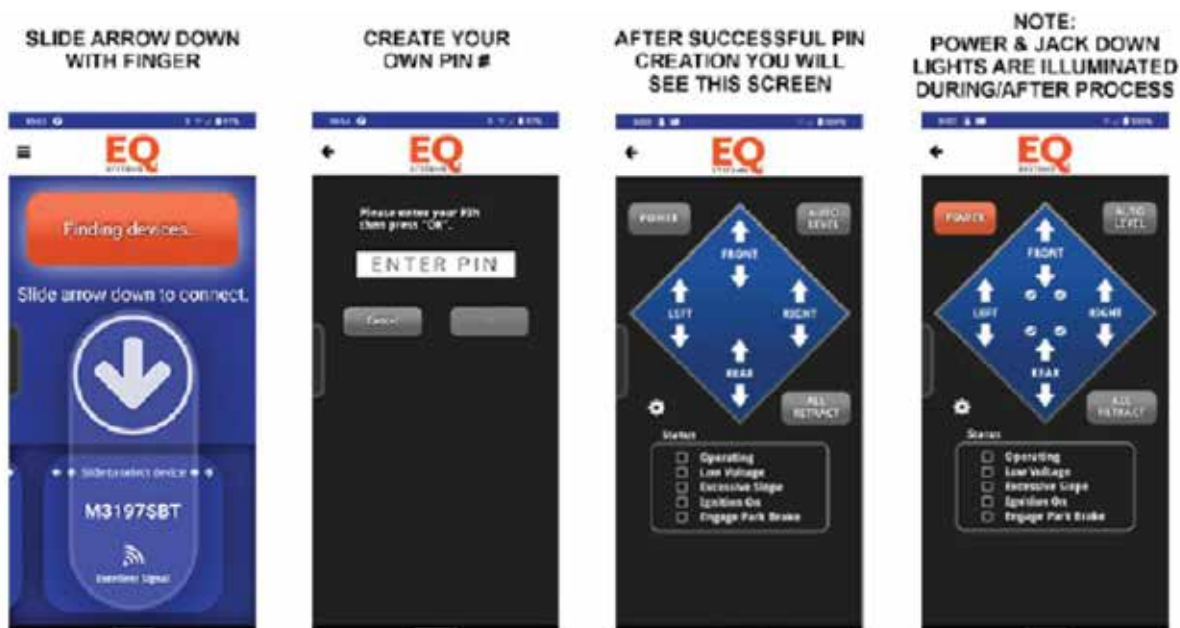

# PANEL INDICATOR LED'S

During typical operation, the LED's on the bottom left hand corner of the keypad should NOT be illuminated. The only LED that should light is the OPERATING LED, which should flash during operation.

<b>Power LED</b>	<b>ON</b> Red when Power is ON <b>OFF</b> when power is OFF <b>SLEEP MODE</b> Flashes every 1 second
<b>Jack LED</b>	<b>ON</b> Red when Jack(s) are deployed <b>OFF</b> when Jack(s) are stowed
<b>Operating LED</b>	<b>ON</b> Red w/Auto Level or All Retract <b>OFF</b> when keypad is idle or sleeping
<b>Low Volatage LED</b>	<b>ON</b> Red when voltage is below 10.5 VDC <b>OFF</b> when voltage is above 10.5 VDC
<b>Engage Park Brake LED</b>	<b>ON</b> Red when park brake is not set <b>OFF</b> when park brake is set
<b>Ignition On LED</b>	<b>ON</b> Red when ignition is in the ON position <b>OFF</b> when igation is off
<b>Excess Slope LED</b>	<b>ON</b> Red following an Auto Level attempt if system cannot overcome slope <b>OFF</b> when slope is not excessive

If the LOW VOLTAGE, or EXCESS SLOPE LED's illuminate, you have an error condition that must be corrected prior to operating the jacks.

**Note: After an Auto-Level process the operation light should turn off and the Excess Slope light should be off. This indicates that the system has finished leveling and is within the .5-degree (approx. 7/16 inch over 4 feet) front to rear and side to side leveling specification.**

**If the Excess Slope light is on, then the system was not able to complete the process within the .5-degree specification. There are several possibilities to include but not limited to Low Voltage, jack(s) running out of travel or system/component failure.**



# MANUAL OVERRIDE OPERATION

- The individual cartridge valves are clustered together on the side of the pump manifold. They are labeled 1 thru 4 (there is one for each jack). Locate the screws recessed in the end of the stem on the appropriate cartridge valve(s). Using a 1/8" Allen wrench, turn the screw(s) clockwise until seated in.
- The pump may or may not have a DV2 valve on the opposite side of the manifold. If it does, use a 1/8 inch Allen wrench, turn the Allen screw clockwise until seated in.
- Remove the foil sticker from the end of the motor. Place the drill with the 1/4 inch Allen driver bit on the manual override shaft located at the end of the motor.
- To retract: Run the drill in the counter-clockwise direction at 2000 r.p.m. (minimum).
- To extend: Run the drill in the clockwise direction at 2000 r.p.m. (minimum).

**Following manual override operation, failure to return all valves to normal position may result in one or more jacks drifting/traveling down from their retracted (stowed) position. For cartridge valves, rotate the center screw fully counter-clockwise.**



## 70201 CROSS TIE ASSEMBLY SPRINTER AND FORD TRANSIT CHASSIS

THIS CROSS TIE ASSEMBLY MAY BE USED ON THE FRONT AND OR REAR JACKS DEPENDING ON THE SYSTEM. BEFORE STARTING INSTALLATION OF THE CROSS TIE, MAKE SURE THAT THE JACK MOUNTING BOLTS ARE SLIGHTLY LOOSE. SLIDE THE TWO HALVES OF THE CROSS TIE TOGETHER (3726 & 3727) AND USING THE CYLINDER CLAMPS (3888) ATTACH THE BRACKETS TO THE JACKS JUST BELOW THE LOWER FITTING. MAKE SURE THAT THE JACKS ARE VERTICAL AND THEN EITHER DRILL A  $\frac{9}{32}$ " HOLE THROUGH BOTH TUBES AND BOLT TOGETHER, OR IF A WELDER IS AVAILABLE YOU MAY WELD THE TWO TUBES TOGETHER INSTEAD OF DRILLING AND BOLTING. AFTER THE CROSS TIE IS SECURE, TIGHTEN THE JACK MOUNTING BOLTS.

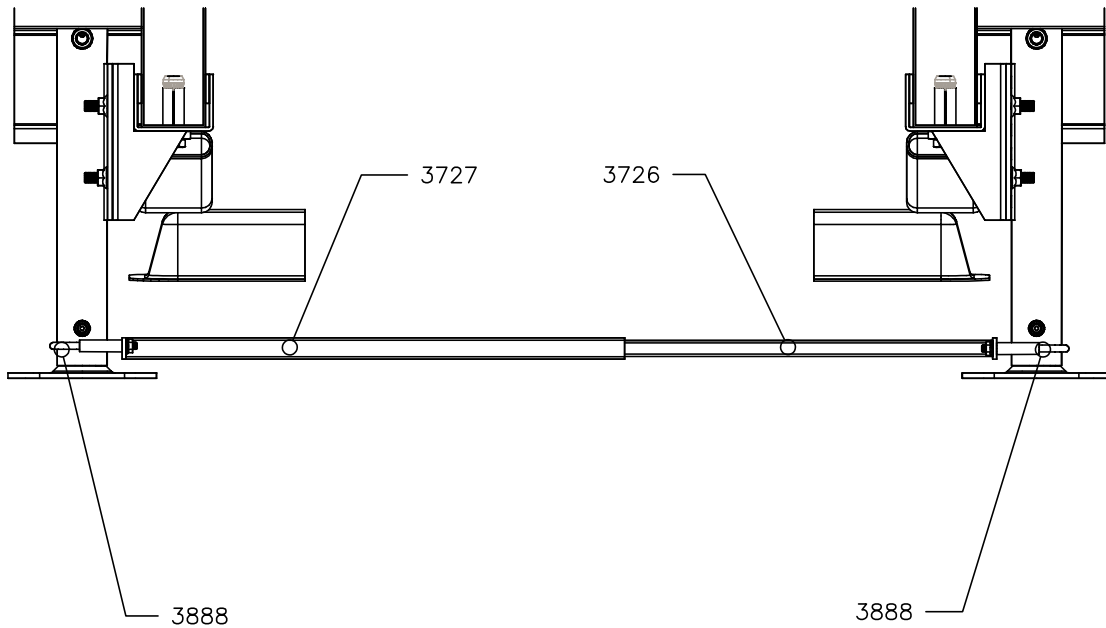

NOTE;  
Torque specification for  
3888 is 18 lb. ft.

- 3888 CLAMP-2  $\frac{1}{4}$ " CYLINDER
- 3726 BRACKET-PS CROSS TIE
- 3727 BRACKET-DS CROSS TIE

# 70309EQ/70310EQ REAR JACK MOUNT INSTALLATION FORD TRANSIT CHASSIS

JACKS CAN BE MOUNTED TO INSIDE OF FRAME (AS SHOWN) OR OUTSIDE OF FRAME. PLEASE NOTE THAT THE SMALL ANGLE BOLTED TO THE JACK BRACKET SHOULD BE UNDER THE FRAME THROUGH EXISTING SLEEVED HOLES IN THE FRAME. LIGHTLY TIGHTEN BOLTS UNTIL THE CROSS TIE HAS BEEN INSTALLED AND THE JACKS ARE STRAIGHT UP AND DOWN. AFTER COMPLETION OF CROSS TIE INSTALLATION (70210) THEN FINISH TIGHTENING THE JACK BOLTS.

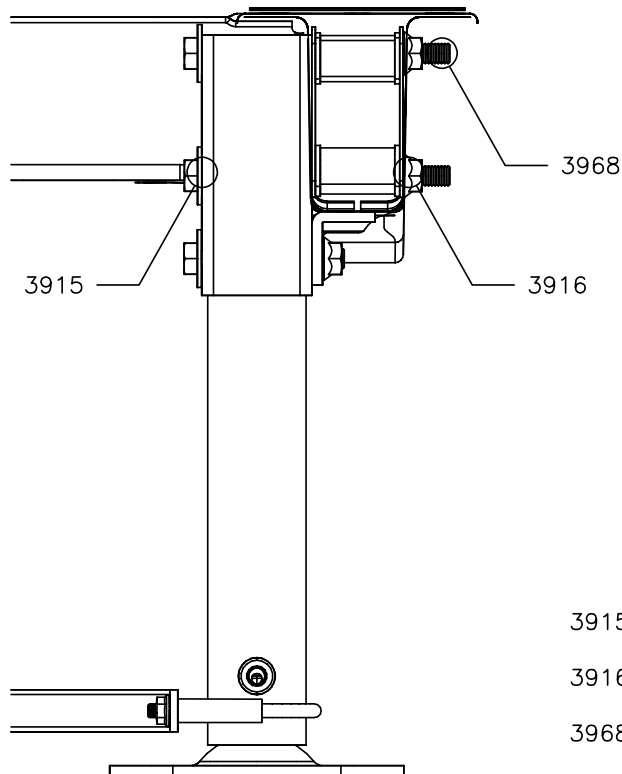
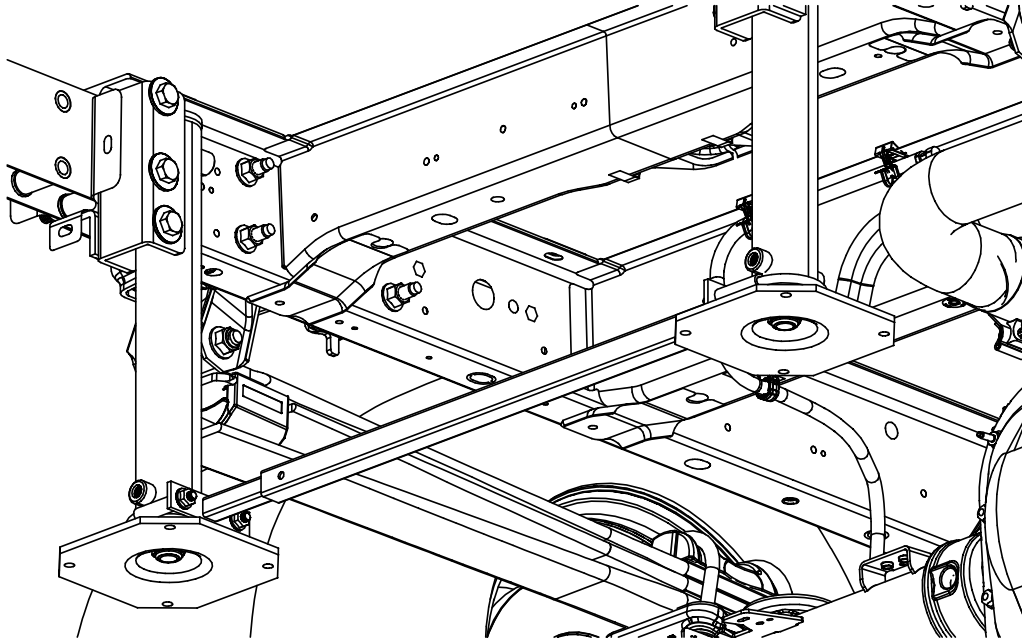

NOTE;  
Torque specification for  
3968 is 75 lb. ft.

3915 1/2" Grade 8 flat washer

3916 1/2" Serrated Flange Nut Grade8

3968 Bolt-1/2"-13 x 6" Grade 8

## 70311 REAR PUMP MOUNT INSTALLATION FORD TRANSIT CHASSIS

LOCATE THE 1 1/8" DIAMETER HOLES IN THE FRAME THAT ARE BETWEEN THE REAR TWO FRAME CROSS MEMBERS. PUT THE PUMP MOUNT BRACKET BETWEEN THESE HOLES. NOTE THAT ONE SIDE HAS A BEND TO GO AROUND THE EXHAUST HANGER. ON THE OUTSIDES OF THE FRAME RAILS, INSERT THE TWO BOLT SLEEVES AND THEN USE THE 3967 BOLTS AND 1200 NUTS TO ATTACH THE BRACKET. TIGHTEN BOLTS TO 80 LB FT.

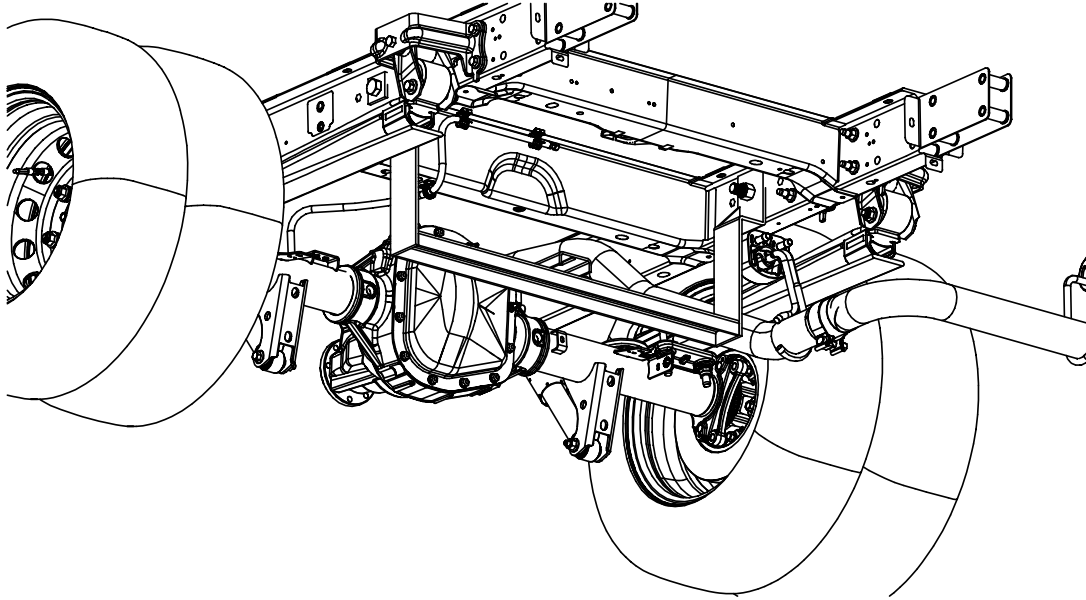

1200 3/4" NC HEX NYLOCK

3967 BOLT-3/4-10 X 4 1/2" HHCS GR 5

3965 BRACKET-PUMP MOUNT-FORD TRANSIT

3966 BRACKET-FRAME SLEEVE-FORD TRANSIT

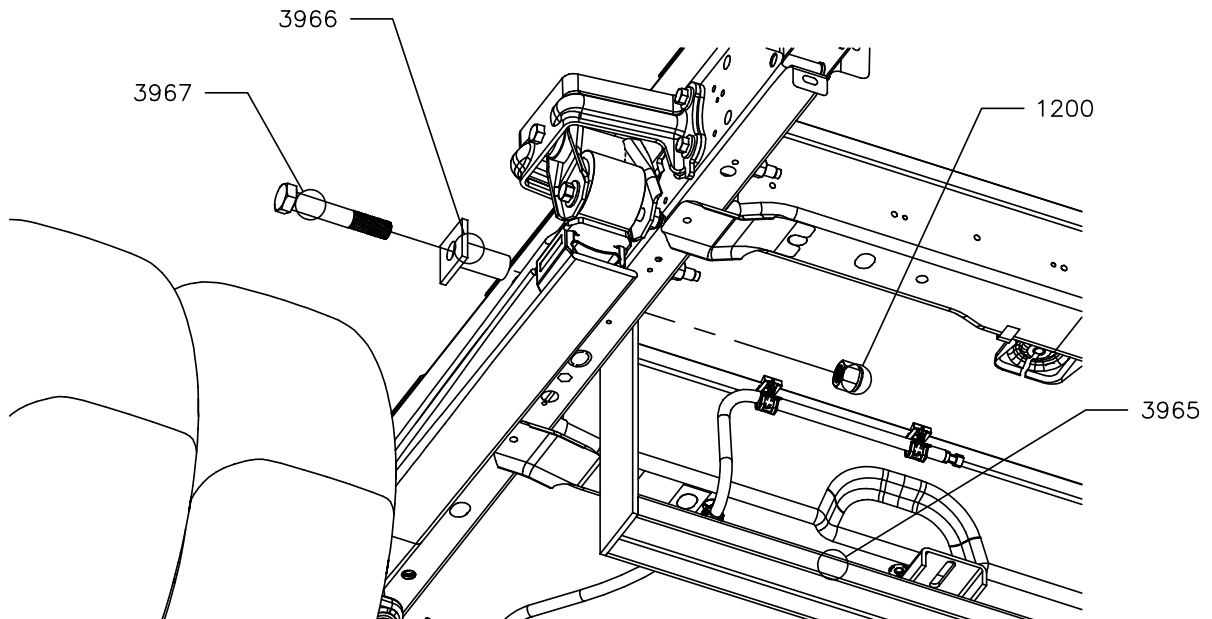

2

DRAWING NUMBER	PART NAME	QTY.
70381L	SL 13 TRF-TRANSIT UNDER CAB-DS	1
70381R	SL 13 TRF-TRANSIT UNDER CAB-PS	1
70201	FRONT CROSS TIE ASSBLY-2019 SPRINTER	1

1

Locate the components highlighted Gold and Red here. There will be a hole approximately 1.3mm (0.51") in diameter a few inches in front of these members. This is where our jacks will be mounted using the box bolts. Insert the sleeve and tighten to 40ft-lbs.

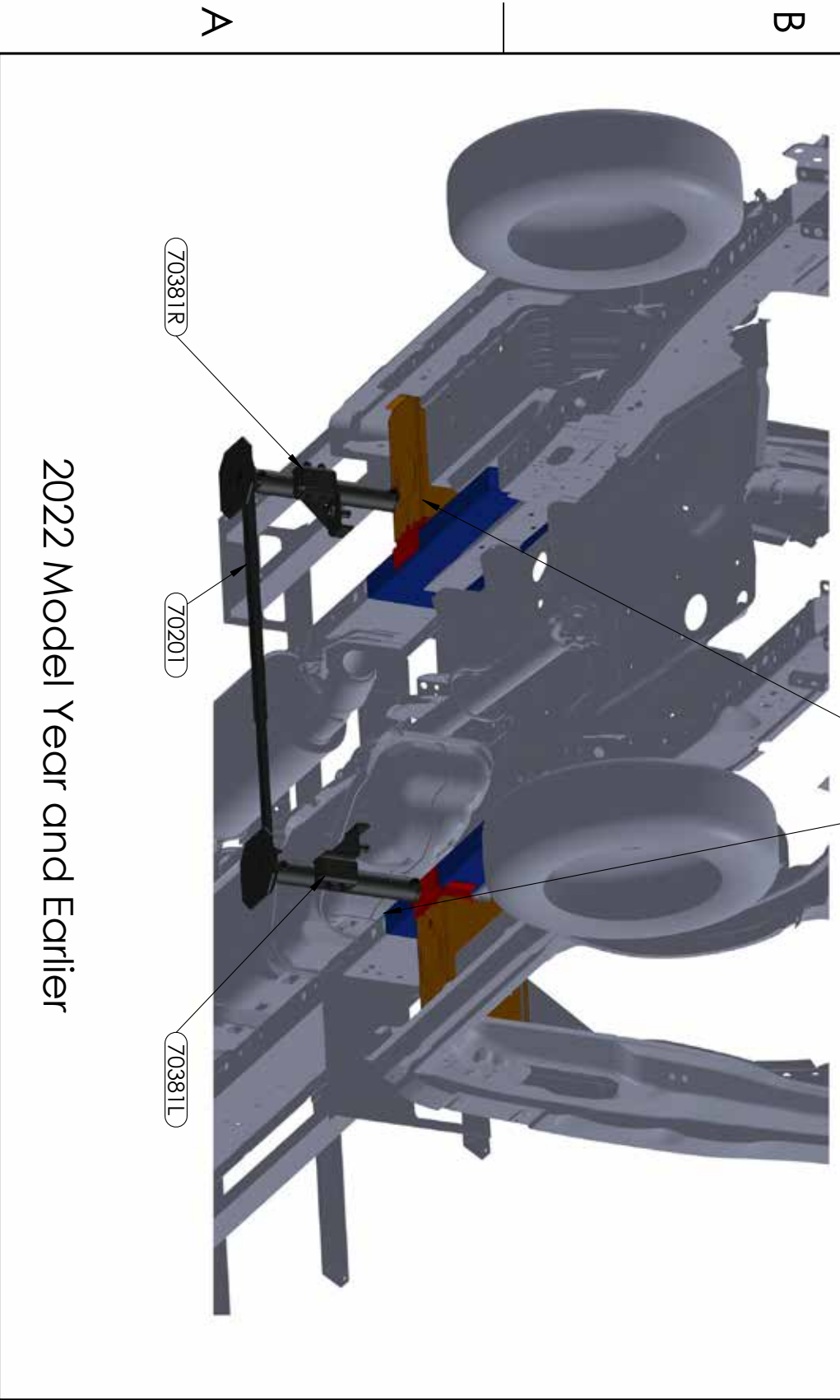

A

B

A

B

2022 Model Year and Earlier

2

1

2

DRAWING NUMBER	PART NAME	QTY.
70201	FRONT CROSS TIE ASSBLY-2019 SPRINTER	1
70446L	SL 13 TRF- 2023 TRANSIT UNDER CAB-DS	1
70446R	SL 13 TRF- 2023 TRANSIT UNDER CAB-PS	1
4411	BOLT-1.42 X 40mm HHCS	4
4412	WASHER-14mm LOCK	4

1

Locate the components highlighted Gold and Red here. There will be two holes approximately 14mm(0.55") in diameter a few inches in front of these members. This is where our jacks will be mounted using the supplied bolts and lock washers. There are threaded inserts in these holes start threading the supplied M14 bolts by hand and tighten to 55 ft.-lbs.

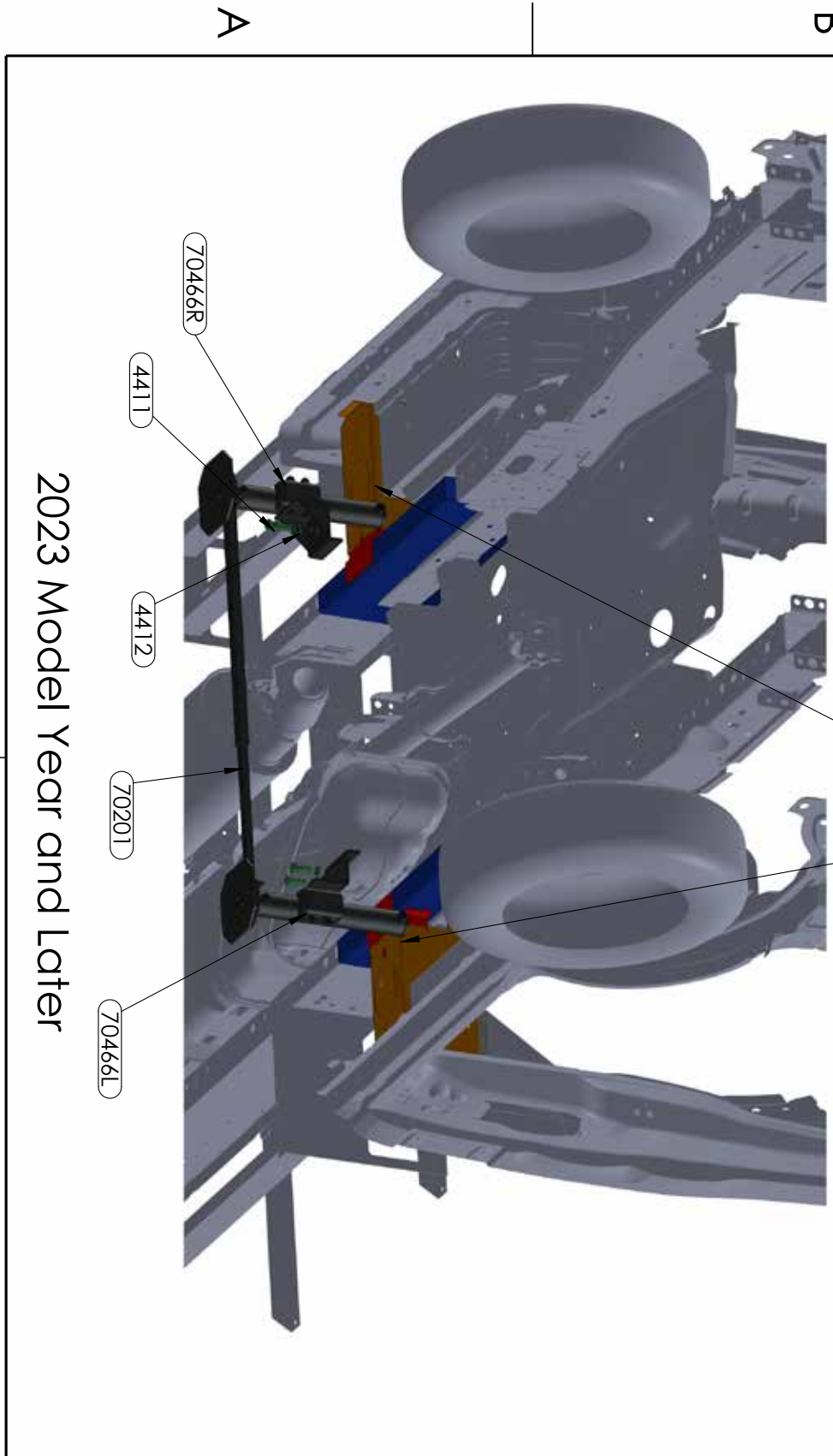

A

B

A

B

2

1

2023 Model Year and Later

# HYDRAULIC HOSE CONNECTIONS 7982KS PUMP

- B = RETRACT FUNCTION
- B1 = LEFT FRONT JACK (BROWN/BLACK)
- B2 = RIGHT FRONT JACK (WHITE/BLACK)
- B4 = RIGHT REAR JACK (YELLOW/BLACK)

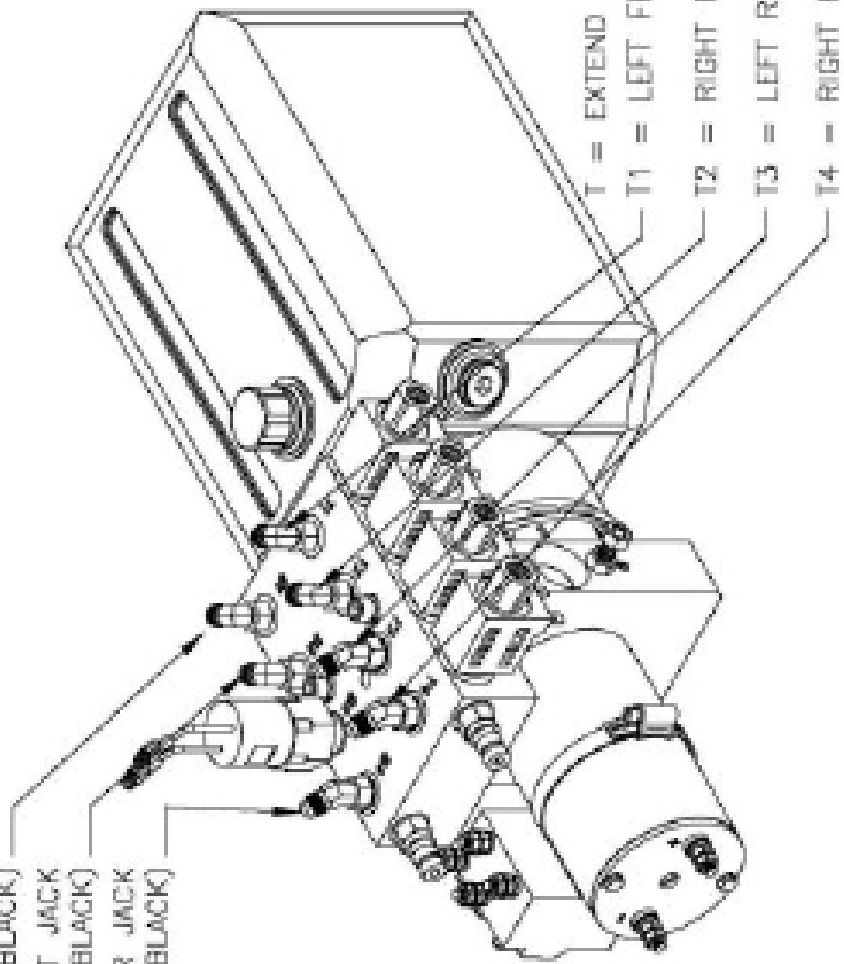

- T = EXTEND FUNCTION
- T1 = LEFT FRONT JACK (BROWN)
- T2 = RIGHT FRONT JACK (WHITE)
- T3 = LEFT REAR JACK (ORANGE)
- T4 = RIGHT REAR JACK (YELLOW)

# 7982KS PUMP WIRING

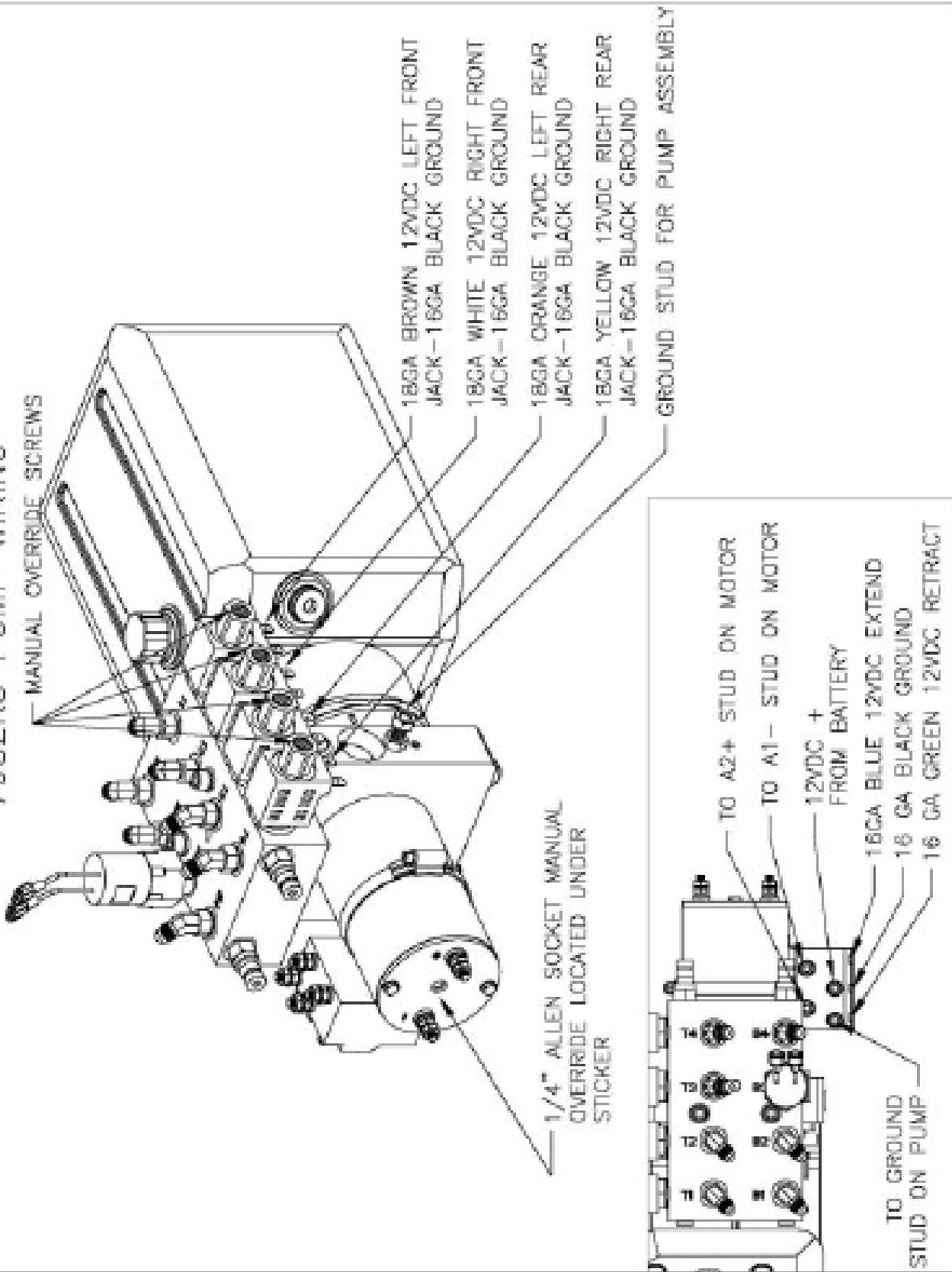

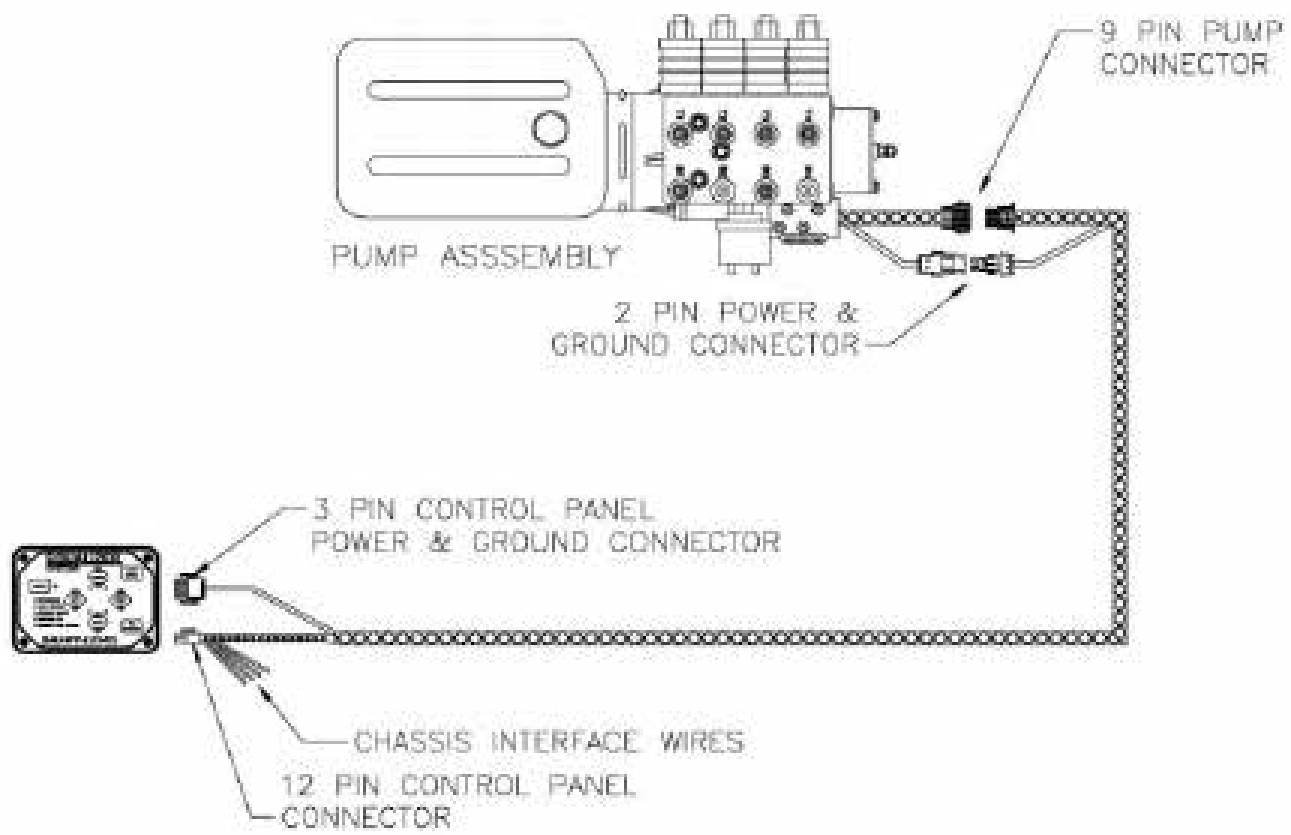

**EQ Smart-Level Control Panel with harness and pump Layout**





(800) 846-9659

## **EQ SYSTEMS TORQUE SPECIFICATIONS**

July 2024

The following list are items that the installer would encounter during the normal installation. The values listed are for EQ supplied fasteners and components. For other fasteners not listed follow EQ Systems specific installation manual instructions and or fastener industry/supplier specifications for fastener size, thread and grade. Generally, EQ systems use GR 5 specifications.

### **Adaptor Fittings At Manifold And Jack Cylinders**

See installation instructions for proper installation/tightening of 90-degree fittings.  
**15-18 LB. FT.**

### **Hose Fittings To Adaptor Fittings At Manifold And Cylinders**

**12 – 15 LB. FT.**

### **Jack Cylinder To Bracket**

**75 LB. FT.**

### **Box Bolt (front Jack mount sprinter chassis)**

**140 LB. FT**

### **Jack Mount Clamp Bracket Bolts**

**50 LB. Ft.**

### **Cross Tie U-Bolts**

**18 LB. FT**

### **Cross Tie Joint Bolt & Nut**

**7 LB. FT.**

### **Pump Mount Stud/Bolt 3/8-16 Stud With Hex Nut (9/16-inch wrench)**

**20 LB. FT.**

### **Electrical Connections**

**Motor Solenoid (contactor, reversing polarity type) Wire Terminals/Battery Positive Connection 6 MM Brass Stud (10 MM wrench)**

**32 to 34 LB. IN.**

### **Motor Solenoid, Uni Directional Type**

**Battery Connection Terminal Stud. Battery Positive Connection.**

**5/16-18 Brass Stud (1/2 or 9/16 wrench) or M8-1.25 (13 mm wrench)**

**6-7 LB. FT.**

**Pump Ground Stud 5/16-18 Stud With Hex Nut (1/2-inch wrench)**

**15-18 LB. FT.**

**Pump/Manifold Replacement Parts**

**Manifold To Lower Assembly Studs/Nuts 5/16-18 (1/2-inch wrench/socket)**

**12 to 20 LB. FT.**

**Manifold Adaptor Fittings And Plugs, Including Purge Coupler Nipples**

**15-18 lb. FT.**

**Pressure Switch**

**12 - 15 LB. Ft.**

**Manifold Valve**

**12 - 15 LB. FT.**

**Manifold Valve Coil Nut**

**4-6 LB. FT.**

**Reservoir Screws 5 mm (8 mm wrench)**

**4.5 LB. FT.**

## **ELECTRICAL**

**Motor Solenoid/Contactors #2994**

**Motor Solenoid (contactor, reversing polarity type) Wire Terminals/Battery**

**Positive And Ground Connection And Contactor To Motor Lead Studs**

**6 MM Brass Stud (10 MM wrench)**

**32 to 34 LB. IN.**

**Motor Solenoid, Uni Directional Type. # 1444 and # 4252**

**Battery Connection Terminal Stud. Battery Positive Connection.**

**5/16-18 Brass Stud (1/2 or 9/16 wrench) or M8-1.25 (13 mm wrench)**

**6-7 LB. FT.**

**Primary Stud Terminal SS # 10-32 (3/8-inch wrench)**

**25-30 LB. In.**

**Motor Attachment Screws 5 mm (8 mm wrench)**

**4.5 LB. FT.**

**Motor Terminal Stud/Nut (10 MM wrench)**

**32 -34 LB. IN.**



## MOTORHOME & FIFTH WHEEL WARRANTY

### **EQ Systems (Equalizer Systems) Limited Warranty Policy May 2022**

1. EQ Systems (Equalizer Systems) warrants slide out and leveling system components for a period of **one year** from the date of original sale of the vehicle. This warranty covers defects in material and workmanship only. EQ Systems (Equalizer Systems) is not liable for any damage due to abuse, neglect, misuse, negligence, misapplication, error of operation, accidental or purposeful damage or damage due to an "act of God" such as, wind or rain damage, flood, lightning, or other natural occurrence of the like. EQ Systems (Equalizer Systems) limited warranty is applicable to the EQ Systems (Equalizer Systems) components only and does not apply to the vehicle, apparatus, or property to which it is attached. Warranty parts will be shipped at no charge if the repair is authorized by an EQ Systems (Equalizer Systems) representative. Purchased components used in authorized warranty repairs will be reimbursed at the original purchase price.
2. Labor and freight expenses due to warrantable parts defects or workmanship will be reimbursed for a period of **one year** from the date of original sale of the vehicle. Freight expenses will either be prepaid by EQ Systems (Equalizer Systems) or reimbursed at the UPS Ground rate only. Any additional shipping charges or requirements are the obligation of the vehicle owner or service center performing the warranty repair. The owner or service center's obligation may include overseas shipping charges, border fees, brokerage fees and any other additional fee of the like.
3. Warranty labor will be reimbursed only for claims that have prior written or verbal authorization from an EQ Systems (Equalizer Systems) representative. Warranty labor compensation is required to correspond with the "OEM Warranty & Procedure Manual" published by EQ Systems (Equalizer Systems). Any warranty repair not listed on this guideline will require prior authorization from an EQ Systems (Equalizer Systems) representative. A reasonable time allowance will be determined by the EQ Systems (Equalizer Systems) representative. Any warranty repair that is not listed on this guideline that is performed without prior authorization will be denied without exception. Time associated with learning about the repair or excessive diagnostic and installation time will not be reimbursed. Warranty labor will be reimbursed at the authorized service center's published shop rate if the rate is reasonable for that region. Overtime labor will not be reimbursed without exception.
4. Labor, parts, and freight credit (if applicable) will be sent when the parts are tested, and the warranty claim is validated. Returned parts that are found to be in normal operating condition are not warrantable and will be charged to the owner or service center. EQ Systems (Equalizer Systems) reserves the right to charge back the service center for labor claim payments previously submitted if the installation of the warranted part is found to be inadequate at a later date.
5. Claims will be denied if the date submitted is greater than 120 days from the repair date.
6. Prior authorization is required before parts may be sent back to EQ Systems (Equalizer Systems). A Return Authorization Number is required for items to be accepted.
7. Complete systems are not warranted unless authorized by an EQ Systems (Equalizer Systems) representative. There are absolutely no exceptions to this clause.
8. Warranty coverage for parts or systems sold by non-authorized resellers (such as live or internet auctions) will be at the discretion of EQ Systems (Equalizer Systems).
9. EQ Systems (Equalizer Systems) is not liable for loss of time, manufacturing costs, labor, material, loss of profits, direct or indirect damages incurred by the vehicle manufacturer.
10. Excessive warranty labor resulting from inadequate access to the EQ Systems (Equalizer Systems) product will not be reimbursed.
11. EQ Systems (Equalizer Systems) will not pay a markup on warranty parts unless required by law.
12. Travel expenses, hotel, telephone, fuel, or any other expenses of the like are not covered under warranty.

#### **Replacement Parts:**

1. Replacement parts are warranted under the same guidelines listed above for the remainder of the original warranty or 90 days, whichever is longer. Proof of warranty repair date and original vehicle purchase date are required. No additional warranties, expressed or implied, are authorized by EQ Systems (Equalizer Systems)

This warranty voids all previous issues.

**Questions concerning this warranty should be directed to:  
EQ Systems (Equalizer Systems) | 19300 Grange Street, Cassopolis, MI, 49031  
574-264-3437 | (800) 846-9659**

**To activate your warranty, please visit our website at [www.eqsystems.us/activate-warranty/](http://www.eqsystems.us/activate-warranty/)**