



EQ SMART-LEVEL 5TH WHEEL VERSION

Installation/Operation/Warranty Guide

Effective February 2021

EQ023R7



(800) 846-9659
EQSystems.us

EQ Smart-Level 5th Wheel Version Installation/Operation/Warranty Guide

Effective February 2021

Contents

<u>Required Tools & Parts</u>	<u>Page 3</u>
<u>Installation</u>	<u>Pages 3 - 15</u>
<u>Jacks</u>	<u>Page 4</u>
<u>Foot Installation For SL Jack Leg Assemblies</u>	<u>Pages 5 - 6</u>
<u>Pump/Fittings/Hoses</u>	<u>Pages 7 - 8</u>
<u>Wire Harness/Install Control Panel/Pump</u>	<u>Pages 9, 11 - 12</u>
<u>Chassis Interface Connection</u>	<u>Page 10</u>
<u>Purging</u>	<u>Pages 13</u>
<u>Control Panel Programing</u>	<u>Page 14</u>
<u>Operation & Setting the Null</u>	<u>Pages 15 - 18</u>
<u>Panel Indicators</u>	<u>Page 19</u>
<u>Manual Override</u>	<u>Pages 20 - 21</u>
<u>Torque Specifications</u>	<u>Pages 22 - 23</u>
<u>Warranty</u>	<u>Pages 24</u>
<u>Diagrams</u>	<u>Page 25</u>

REQUIRED TOOLS AND PARTS

Tools Required for Installation

- Ratchet, sockets and wrench set
 - Wire cutters/crimpers
 - Electric drill/screw gun and bits
 - Welding equipment (if welding leg or bracket in place)
-

Additional Items Required for Installation

- Fasteners for mounting jacks to frame, minimum 1/2" diameter grade 5
- # 4 AWG power wire **(to connect battery +12V positive to the pump) *
- # 4 AWG ground wire **(to connect battery -12V ground to pump) *
- # 4 AWG ring terminals **
- Circuit breaker 100 or 150 amp manual reset type. For additional information please see page 14.
- Loom clips (to secure harness and hydraulic hoses to the coach)
- Self-drilling screws or pop rivets or other to secure harness and hoses.
- Wire ties
- 10 – 16 quarts, could be more depending on system, Automatic Transmission Fluid (Dexron or multi-purpose ATF)

***Note:** These items must be # 2 AWG or larger if cable run is greater than 12 ft

**Note: Modification of any factory supplied item may result in the denial of all warranty claims.
Call EQ Systems Technical Support prior to any modifications.**

With any hydraulic application, holding position on a cylinder must be done with safety in mind. Failure in the system may cause the jacks to retract or extend suddenly. When working under or near the coach, always use jack stands of appropriate rating to support the weight of the coach.

JACKS

- The jacks will have to be bolted to the brackets using 1/2" diameter fasteners, min. grade 5.
- The jacks must be mounted to the chassis frame as close as allowable to the front and rear axles.
- The jacks must have a minimum of 6 inches from the ground with the foot pads no lower than anything on the coach. Retract the jack fully, and determine the ground clearance by measuring to the bottom of the jack foot.
- Make sure that the foot pads on the rear jacks are inside the angle of departure.
- The foot/pad must be mounted within range suggested (see chart below) for proper operation of the system.

Due to variables with the different vehicles and jacks involved, the placement and process (Bracket welding, Square Tube Welding) of the jack brackets likely will be on a case by case basis.

- For some they can be directly bolted to the existing mounting brackets or structure.
- For some the brackets may need to be welded to the frame, to which the jacks can be bolted.
- For some square tube jacks they may need to be welded directly to the frame or structure.

Reference Chart for Installing Jacks

SL (round tube jacks)		AJ/AM/CT/SM (square tube jacks)	
		Jack Travel (Stroke)	Rec. Ground Clearance
SL-15	8-10 inches		
SL-16	8-10 inches		
SL-18	10-12 inches	16 inch	8-10 inches
SL-24	14-16 inches	20 inch	12-14 inches
		24 inch	14-16 inches
		30 inch	16-18 inches
		36 inch	18-20 inches

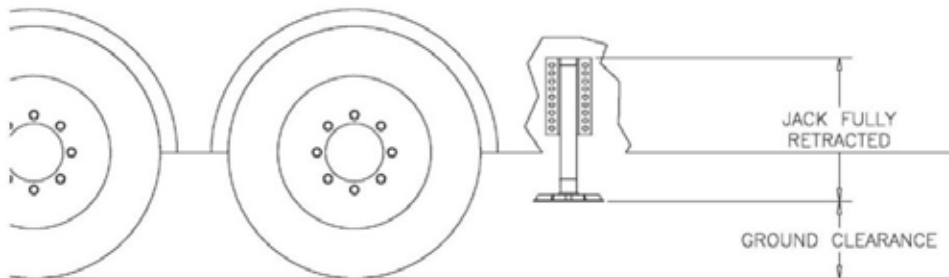

If there are any questions, please call EQ Systems (800) 846-9659.

FOOT INSTALLATION FOR SL STYLE JACK LEG ASSEMBLIES

SL 18, SL 16 and SL 15 Leg Assemblies

This assembly utilizes the 3/4" Flat Head Allen Bolt, 3/4" X 1 1/4" FHSCS - EQ part # 1383.

Required for installation:

- 1/2" drive impact gun
- 1/2" drive X 1/2" Allen Hex socket
- Compressed air source and air blow gun

Process

1. Hold foot pad in place at end of cylinder rod with the cupped end to the cylinder rod.
2. Insert the bolt (part # 1383) through the hole in the center of the foot pad into the threaded end of the rod. Turn clockwise by hand to start (you may use the 1/2" Allen bit to help). Be sure that the bolt starts in straight and is not cross threaded.
3. Using the 1/2" Allen drive bit and 1/2" impact wrench/gun, tighten the bolt into the rod. Allow the impact wrench to impact/drive the bolt totally to full depth. Note that the cylinder rod will/may rotate as you do this.

Notes

- When completed the foot is not intended to be tight. It is designed to pivot slightly and will be free to rotate when the cylinder is slightly extended.
- There is a "foam" cushion or damping ring that is attached to the bottom of the cylinder body with adhesive. Its only purpose is to keep the foot from rattling when fully retracted. If it comes loose/falls it may be glued back up to the bottom of the cylinder or it may even be removed. Replacement part number for this ring on SL 15 and SL 16 is part # 1800. Replacement part number for the ring on SL 18 is part # 1799.
- Some cylinder rods may have a rubber ring around them that may stick to the rod as it is extended. This is a protection ring that is used in production to keep paint from the rod and lower seal area. It may be ignored or removed; it has no other use. Its presence or lack of is not a defective component.

See drawing on next page.

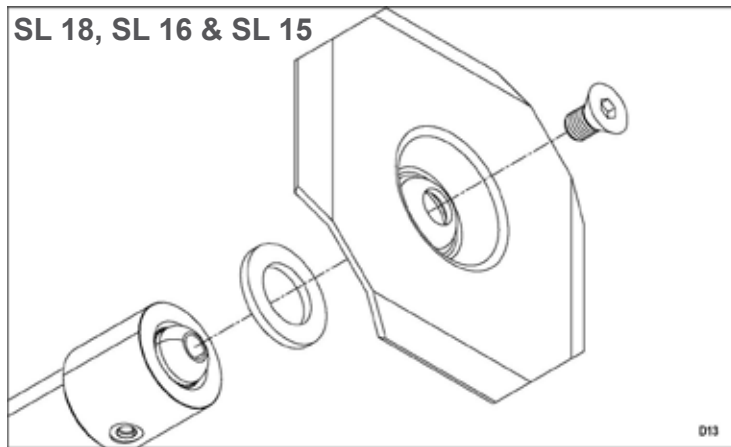

SL 13 Leg Assembly

This assembly uses the 3/4"-16 nylock jam nut.

Required for installation:

- 1/2" drive Impact wrench/gun
- 1/2" drive X 1 1/16" socket (6 point preferred)

Process

1. Check/verify that the threads on the end of the cylinder rod are clean and not damaged. Use the nylock nut to check that it will thread (start) on the end of the rod. Do not fully install or tighten at this time. Remove the nut.
2. Position the hole in the middle of the foot pad over the threaded end of the rod. Start the nylock nut onto the threads by hand.
3. Using the impact wrench/gun and the 1 1/16" socket, tighten the nut onto the rod. Note that the rod may rotate as you are doing this. Tighten the nut until between 1 and 3 threads are visible past the end of the nylock nut.

Notes

- When properly installed, if the cylinder is extended slightly, the foot should pivot slightly and will be free to rotate.

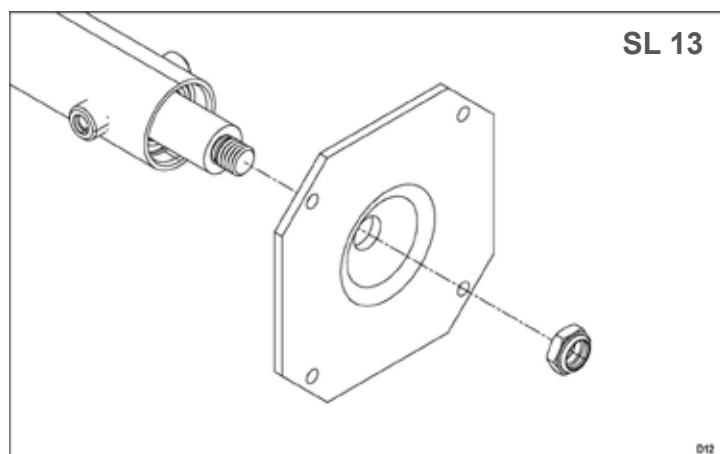

PUMP

Use the 3/8-16 threaded holes in the base of the pump assembly for mounting.

When installing the pump on the coach the location should provide access to:

- Route the hydraulic hoses to the manifold.
- Fill the reservoir and monitor the fill level.
- The cartridge valves and the end of the motor in case manual override of the system is required.

FITTINGS

Install the hydraulic adaptor fittings in the top and bottom of each jack and install the fittings into the manifold.

- The straight thread O-ring side always goes to the cylinder or manifold.
- The tapered side will get the hose attached to it.
- When installing straight fittings into the leg or manifold, tighten to 15 lbs-ft. When using 90-degree fittings, turn until finger tight, position correctly, then tighten the jam nut to 15 lbs-ft.

HOSE

Install the hydraulic hoses according to the chart.

- Route the hoses clear of all hot exhaust components and pinch points in the suspension/chassis system. (moving objects, sharp edges and high heat sources)
- Attach the hoses to the manifold and jack fittings.
- Tighten to 15 lbs-ft. Secure the hydraulic hoses with wire ties or loom clamps to the chassis.
- Care should be taken to not kink or twist hoses.
- The min. bend radius is 6 inches.

Installation of Hoses to the Manifold

Jack Leg

Manifold Connection

Left Front - Top	Brown Solid (T-1)
Left Front - Bottom	Brown Stripe (B-1)
Right Front - Top	White Solid (T-2)
Right Front - Bottom	White Stripe (B-2)
Left Rear - Top	Orange Solid (T-3)
Left Rear - Bottom	Orange Stripe (B-3)
Right Rear - Top	Yellow Solid (T-4)
Right Rear - Bottom	Yellow Stripe (B-4)

See drawings on next page.

Note: Some trailers have 6 jacks. When this is the case, the rear jacks, 2 left and 2 right, are connected in pairs - left pair and right pair. See the drawing for this on page 24.

HOSE CONNECTIONS

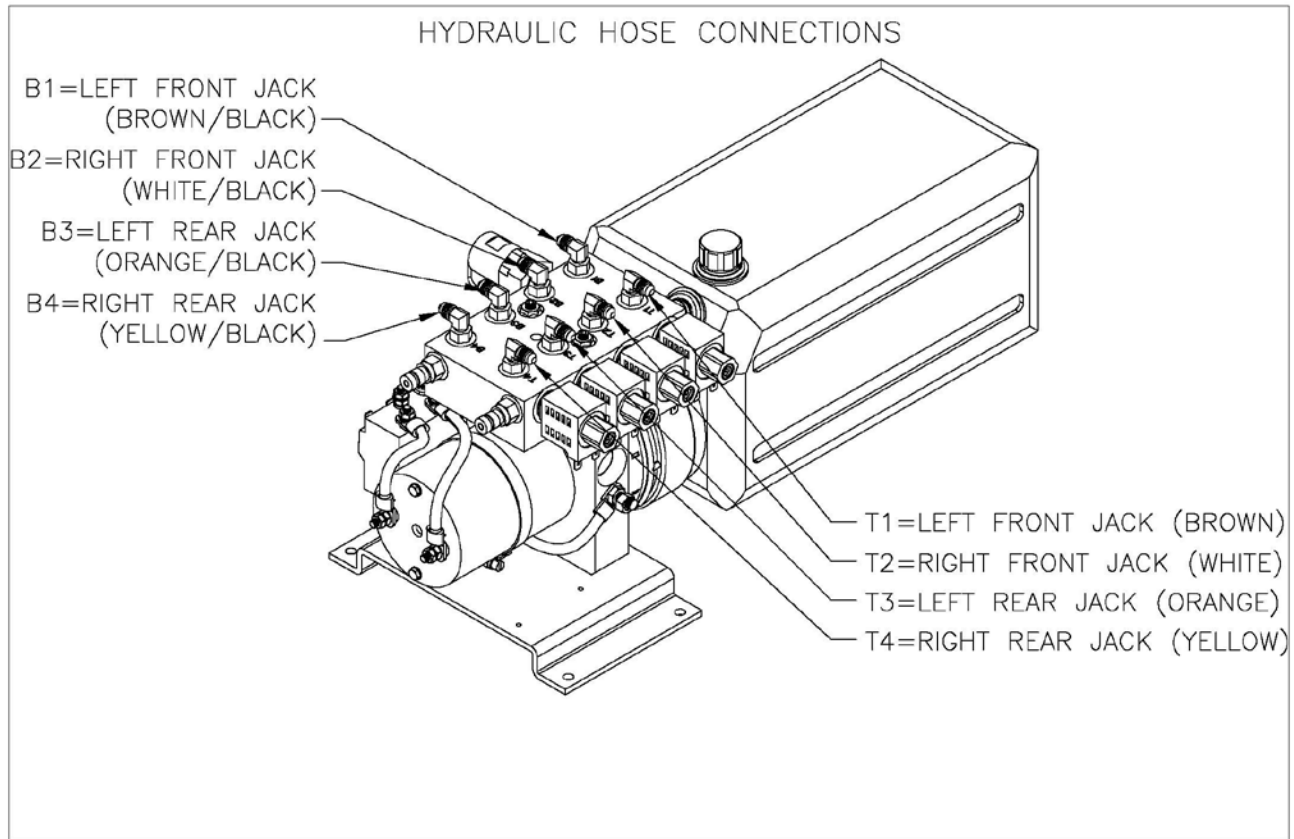

WIRE HARNESS

Route the wire harness from the pump assembly to the area where the control panel is to be mounted.

- The harness needs to be routed away from moving objects, sharp edges, and high heat sources.
- Use wire ties and/or loom clamps to secure in place.
- The end with the 9-pin and 2-pin connector goes to the pump assembly. (See the drawing for the layout.)
- Connect the harness connectors to the matching connectors at the pump assembly.

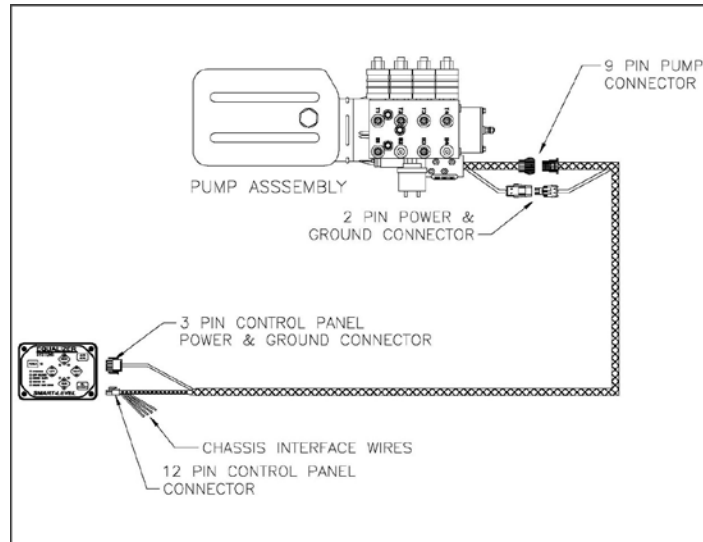

EQ SMART-LEVEL CONTROL PANEL

Fasten control panel (vertically or horizontally) in desired location.

- It may not function well right at 45 degrees. The most accurate will be right at horizontal (0 degrees) or vertical (90 degrees).
- It may be mounted on any surface regardless of its orientation to the front of the vehicle
Examples: on the center console, vertical wall, cabinet wall or other firm structure.

- The control panel is not waterproof therefore it must be in an interior location or compartment protected from the elements and spill areas.
- Attach the supplied wire harness between the Control Panel and the location of the pump assembly.
- There are two connectors, one is a 12-pin double row and the other is a 3-pin, which is the power and ground feed for the control panel.
- There may be additional optional connectors that are not used for most installations. There may be additional wires breaking out of this harness, they are discussed on page 10 in chassis interface.
- The control panel must be firmly mounted to a surface that 'reacts' with the coach during leveling. The Auto Level function requires this as the leveling sensors are located inside of the control panel.

A set up process known as Orientation Program followed by setting the Null (described later) must be performed. If these steps are not completed the Auto Level function will not operate properly. See orientation and null settings for these processes.

CHASSIS INTERFACE CONNECTIONS

The below items are designed primarily for motorized vehicles. When installing on a trailer the Ignition disable is not required and the wiring may not be present in the supplied harness.

- If the pink wire is present, just tape it back.
- If the black/yellow wire breakout is present it will need to be connected to a ground source (this is pre-connected to ground inside of many harnesses designed for trailers).

It is possible to use these disables on a trailer as an interlock that will prevent extension operation, but this is not required for most installations. The use of these “interlocks” is at the discretion of the trailer/vehicle manufacturer. Call EQ Systems for further information.

**Please note that Step 1 and 2 are required on motorized units.
Step 3 is optional and generally is only used on motorized units**

Step 1 - Keypad Ignition Disable Circuit

- Note the “break-outs” near the end of the keypad harness. The Pink wire must receive a +12 VDC input when the ignition key is in the “on” position.
- Connect this wire to the ignition positive. This will make the wire “hot” and will prevent jack extension when the vehicle ignition key is in the on (engine run) position. This also provides for a “jacks down” warning in the event of a jack drifting from the stowed position during travel. This connection is required on motorized vehicles.
- Failure to make this connection may create an unsafe condition and may void the warranty (on motorized units).

Step 2 - The Black/Yellow Wire Must Receive a Ground Input

- This black/yellow wire must be connected to a chassis ground.
- If this wire is not connected to ground, the Engage Park Brake light will be on and Auto Level will be Denied.

Step 3 - Optional Park Brake Connection for Black/Yellow Wire

Contact your chassis manufacturer to verify park brake chassis connection and location. This connection must be done by a technician qualified for chassis electrical systems.

- Most chassis manufacturers are now doing this through the Dash Module. Attempts to connect this improperly could lead to dash feedback or other issues.
- This connection to a park brake signal is optional. If this input is not connected to the park brake signal or to ground, Auto Level will be continuously denied.
- Also, the engage park brake light will be on if the panel is powered up or the key is in the on (engine run position).

WIRING

Power Connections for Pump # 2542KS

Attach a # 4 gauge wire (# 2 gauge if the run is over 12ft.) from the **positive** +12V terminal on the battery to the + terminal on the motor solenoid. There will be a yellow fused wire on this terminal.

- This supply may be fused at the source with a 150-amp circuit breaker.
- This +12v supply must be a dedicated and isolated circuit (not shared with other devices), and must be constant, non-switched +12vdc.

Attach a # 4 gauge wire (# 2 gauge if the run is over 12ft.) between the **negative** -12v terminal on the battery and the ground stud on the pump.

- This is the preferred method of grounding. If grounding the pump to the chassis, the connection must be sound, free of paint and not susceptible to corrosion.
- The battery must be connected to the frame with # 4 gauge or larger wire.

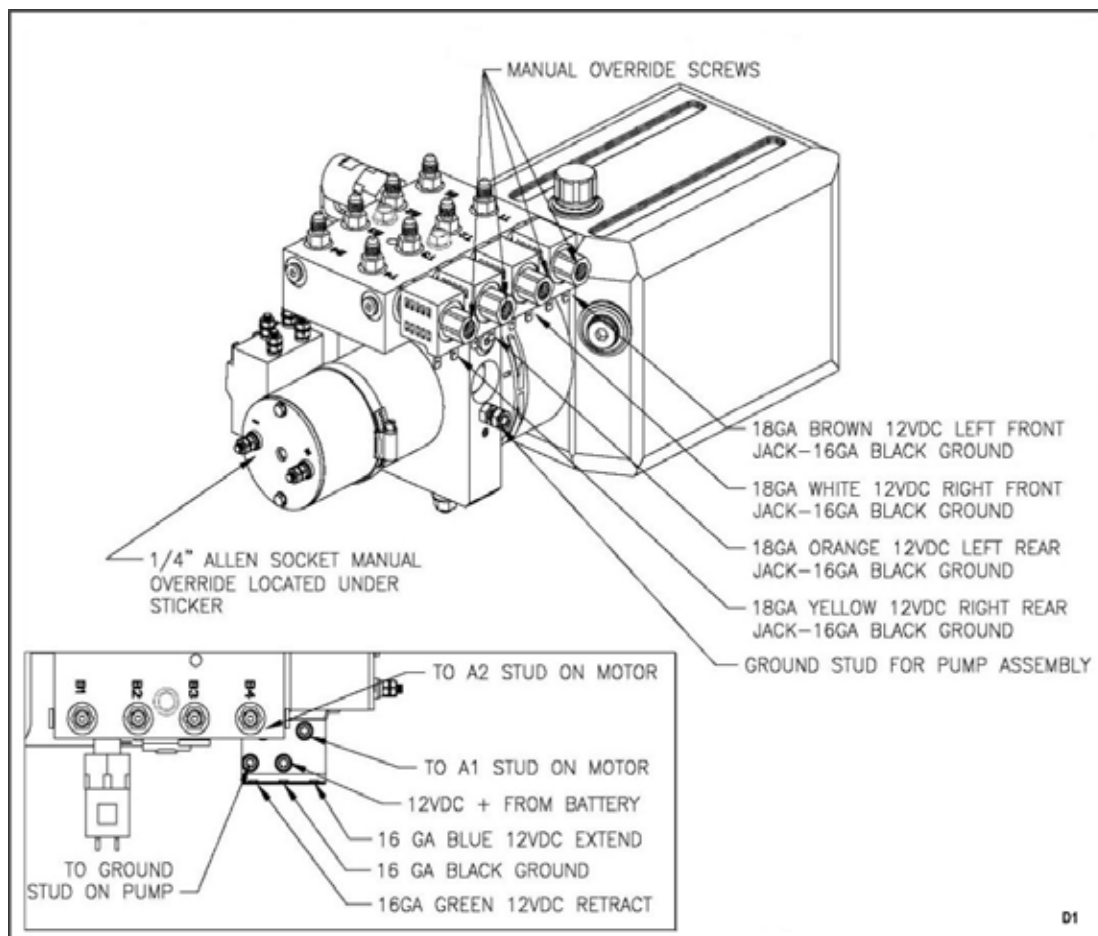

Note: All wire gauge sizes and breaker ratings noted are the recommended size. Larger gauge wiring and higher breaker rating may be used. There may be variances on specific systems supplied to OEM customers due to the exact makeup of the system.

Additional information on Power Supply connections

The below is just general information to be used as a guide.

Pump #'s	Recommended Min Wire Gauge Size	Circuit Breaker	Normal Pump Amperage
3195KS, 3195, 3043	4 or 6 Gauge	100	40 - 100
2542KS, 2532, 2542	2 or 4 Gauge	150	60 - 140
3218	2 or 4 Gauge	150	60 - 140
1551	2 or 4 Gauge	150	60 - 150

Battery Size Considerations

Generally, the greater the size of the battery or bank the better. A group 24 RV deep cycle marine battery should be considered the minimum.

Multiple batteries connected in parallel is common. The battery or bank should have some sort of charging system in place to keep the battery or bank at peak charge for proper operation.

Circuit Breakers

The breaker should be of the manual reset type that is typical of the RV/Marine industries usage. This should be of the “slow blow or trip type” to avoid nuisance tripping due to current surges common to the hydraulic pump motor start up. These surges may be many times the normal pump amperage generally lasting only milliseconds.

Note: if a fuse is used in lieu of a breaker, a “slow blow” type of higher amperage rating is recommended to prevent nuisance “blowing” of the fuse.

The purpose of the breaker is to provide protection against shorting to ground of the positive feed to the pump assembly. It is not needed for system overload protection which is provided by the hydraulic systems relief circuit.

Battery Type and Size

A minimum group 24 RV/marine type battery is recommended. Battery rating should be a minimum 100 RC (Reserve capacity) with a 500 CCA (Cold Cranking Amperage). The higher these numbers the better. Common types are flooded lead acid, Gel and AGM (Absorbed Glass Mat).

Note: Some lithium batteries are not suited for this application. As they cannot provide the high running amperage and surges. Check with the battery supplier/manufacture for info on this.

Additional Notes on Wiring

There may be additional wiring at the pump or near the control panel for specific OEM requirements. Check with EQ Systems on the usage of these if present.

PURGING/FILLING WITH FLUID

Purging Bi-Rotational Pump #s 3195KS and 2542KS

You must follow this procedure strictly. Any deviation from the process will cause the purging process to become difficult and time consuming.

1. Fill pump reservoir to full approx. 1 to 1 ½ inch from top with automatic transmission fluid, the multipurpose or any of the Dexron/Mercon fluids will work.
2. Using the manual switch for the front jacks extend the front jacks until they make ground contact. Do not lift the vehicle. If the vehicle is on a lift the jacks may be fully extended.
Note: extend is the arrow pointing up.
3. Press all retract switch. After the front jacks have fully retracted and the pump shuts off check the reservoir fluid. Refill to full approx. 1 to 1 ½ inch from top.
4. If the fluid in the reservoir is aerated or foamed up, allow time for foam/air to dissipate before continuing. Allow 10 minutes for foam and air to dissipate.
5. Using the manual switch for the rear jacks extend the rear jacks until they make ground contact. Do not lift the vehicle. If the vehicle is on a lift the jacks may be fully extended.
6. Press all retract switch. After the rear jacks have fully retracted and the pump shuts off check the reservoir fluid. Refill to full approx. 1 to 1 ½ inch from top.
7. If the fluid in the reservoir is aerated or foamed up, allow time for foam/air to dissipate before continuing. Allow 10 minutes for foam and air to dissipate.
8. Using manual switches extend to full extension of front and rear jacks. At this point jacks may be allowed to lift the vehicle. Allow 10 minutes for foam and air to dissipate.
9. Press all retract switch. After the jacks have fully retracted and the pump shuts off check the reservoir fluid. Refill to full approx. 1 to 1 ½ inch from top. Allow 10 minutes for foam and air to dissipate
10. Check fluid level. Fill to full 1 to 1 ½ inch from top.
11. Repeat steps 7 through 10.

The above purging process is for dealers and retail installation. High volume OEM installers may have special procedures utilizing special equipment. Call EQ Systems for assistance.

EQ SMART-LEVEL CONTROL PANEL PROGRAMING

After the system is fully installed the control panel must be programed for operation. Failure to do this will result in a failed or improper Auto Level. There are two program settings that must be programed in the following order - 1) Orientation and 2) Null.

Step 1 - Orientation Setting

- This process cannot be completed until after the system has been connected to power and the control panel has been mounted and all electrical harness connections have been completed.
- This process teaches the control panel where the front of the vehicle is and how the control panel is mounted (vertical or horizontal). If this process is not performed correctly the processor will not know where the front of the vehicle is.
- It is possible that without doing this process it may work on a level floor/shop environment however when at sites where the system needs to operate specific legs for leveling it very likely will operate the improper legs.
- Once this process is properly completed the setting will be “retained” in the control panel and should not ever need to be performed again unless the control panel is replaced or moved to a different location.
- With the control panel off, press and hold the ALL RETRACT button, then while holding it press the POWER button, then release both buttons. The power light will start blinking and you will hear a rhythm beeping, and the 4 jacks down indicator lights will be on.
- Next the orientation is selected by pressing one of the manual control arrows. The exact specific one is determined by how the panel is mounted (see examples below). You will select an up arrow if the panel is mounted vertically and down arrow if it is mounted horizontal. The specific one is the one that most relates to the front of the coach.

Examples

- If the panel is mounted vertically inside the vehicle so that when you are looking at it, you are also looking at the inside of the front of the vehicle. You would push the UP ARROW for the front jacks.
- If the panel is mounted vertically inside the vehicle so that when you are looking at it, you are also looking at the inside of the rear of the vehicle then you would press the UP ARROW for the rear jacks.
- If the panel is mounted vertically on the vehicle so that when you are looking at it, you are also looking at the side of the vehicle then you would press the UP ARROW for the left or right jacks depending on which is the closest to the front of the vehicle.

Step 2 - Setting the Null

Null is the term used to indicate the levelness of the coach. A Null setting should have been performed by the installer. If the coach is not level following an attempt to Auto Level, you will need to level the coach and reset the null.

Use a bubble level on a flat surface in the center of the coach as a reference. You do not need to have the jacks deployed to set the null.

- To set the null, first press the POWER button on the keypad to activate the unit. The LED light next to the Power button should be lit RED when the power is on.
- Level the coach by deploying jacks manually, or by simply parking the coach on a level site. Once the coach is level, turn the POWER off at the panel.
- While holding down the AUTO LEVEL button, press and release the POWER button. This should cause the keypad to make a series of beeps.
- After the Keypad has beeped 5 to 6 times, release the AUTO LEVEL button and you will get a confirmation beep. (The Keypad will continue to beep if the Auto Level button is held) The new null has been set and the panel will store/remember this setting.
- Press and release the ALL RETRACT button to retract the jacks to the stowed position.

Note: if you are not clear on this process please check our website for videos and/or call EQ Systems for assistance.

EQ SMART-LEVEL OPERATION

Power On:

Push and release the Power Keypad button to engage power.

- All lights should come on, then most will go out. The LED light next to the Power button should be lit RED when power is on. Other lights should go out, if they do not, refer to the Keypad LED section.
- If the rear jacks down lights are on, they must be cleared by pressing the all retract button prior to performing Auto Level.

Front Jacks:

On a trailer version, Auto Level it is required that tow vehicle be disconnected from the trailer prior to leveling with Auto Level.

- Use the UP Arrow(s) on the control panel (or use the dual leg switch, if equipped) to extend the front jacks to support the trailer and lift the trailer from the tow vehicle.

Auto Level:

Press the Auto Level button and release. The system will send out a continuous series of beeps and the “Operating” LED will flash RED to let you know Auto Level is operating.

- The front may/will lower then the rear legs will be deployed and planted.
- Next the system will use the front and the rear legs to automatically level the coach. When completed, the Keypad will signal the successful completion with a dual-stage tone.
- The Keypad may be left on once level has been achieved. The Keypad will enter “sleep mode” after five minutes of inactivity. If the unit is not level after the process is complete see the section on setting the Null.

Note: During the auto level process no movement in or of the vehicle can be allowed as the system is motion sensitive.

Retracting the Jacks:

Use the ALL RETRACT button to retract the jacks prior to travel.

The EQ System does provide the ability to retract the jacks using the Down Arrows for jacks. However, these buttons are not intended to be used for retracting the jacks to their stowed position prior to travel. The Down arrows are to be used only for retracting the jacks to help level the coach.

- The ALL RETRACT button must be pressed to insure the system is ready/safe for travel.
- Jacks (rear only) will automatically retract and return to stowed position when the ALL RETRACT button is pressed and released.
- On a trailer version system, the front jacks will need to be retracted using the Down arrow to retract the jacks to the stowed position after coupling to the tow vehicle.
- When ALL RETRACT is pressed, the pump will run in retract for approximately 5 seconds after the last jack (rear jack on a trailer version) has been fully retracted or until a time limit has been reached.

Helpful Hints

- Do not allow movement/motion in the coach during the Auto Level operation. This could cause the system to fault out or level/stabilize improperly.
- The Auto Level is a microprocessor-controlled system. Proper and adequate battery voltage and permanent chassis ground are essential.
- Your system is equipped with override ability. Refer to the procedure for proper use of this. It is usually better to review this procedure prior to its actual use, rather than having to learn a new procedure in difficult environments and/or situations. This is designed to get the jacks retracted if there has been a power/control failure.
- If the system has not been used (with the jacks stowed) for over 24 hours, it is recommended that you engage the ALL RETRACT button prior to travel in order to re-pressurize the system. The jacks down status lights may come on regardless of the position of the jacks if the unit has been sitting for a while. Also, if power to the system is interrupted, the status lights may be on requiring an ALL RETRACT performed to clear.

For safety reasons keep people and pets away from jacks and the trailer during jack operation.

Manual Operation

- Push and release the Power Keypad button to engage power. All lights will come on, then most will go out.
- Using the Up Arrow, extend the jacks until they contact the ground (this is referred to as “planting” the jacks). As you extend the jacks, an LED light on the Keypad will indicate the jack(s) is out of the “stowed” position. Jacks may only be operated in pairs using the manual keypad Arrows.
- Jacks should always be used in the following order. Fronts first to support and disconnect the unit free of the tow vehicle. Press the up arrow for the front jacks to extend and lift. Then the rears, extend by pressing the up arrow for the rear jacks until they contact the ground and lift/stabilize the rear.
- Manual leveling should always be done front to rear first then side to side adjustments can be made.
- The left and right-side manual control Arrows will not function until after the unit has sensed that the rear jacks have been planted. If not done properly, a “deny tone” will be given. In the event of this, use the up Arrow for the rear jacks to further extend the rear jacks and lift the unit.
- Use a bubble level on a flat surface in the center of the coach. Level the vehicle by using the Down or Up Arrows until the vehicle is level. Jacks may be operated only in pairs. The Keypad may be left on or powered off once level has been achieved. The Keypad will enter “sleep mode” after five minutes of inactivity.

It is always the responsibility of the coach operator to visually confirm that the jacks are fully retracted and safe for travel.

Retracting Jacks

Use the All Retract button to retract the jacks prior to travel.

- This system does provide the ability to retract the jacks using the Down Arrows for the jacks. However, these buttons are not intended to be used for retracting the jacks to their stowed position prior to travel. The Down Arrows are to be used only for retracting the jacks to help level the coach.
- The All Retract button must be pressed to insure the system is ready/safe for travel. The rear jacks should automatically retract and return to stowed position when the ALL RETRACT button is pressed and released.
- The pump will run in retract for approximately 5 seconds after the last jack has been fully retracted- or until a time limit of 90 seconds has been reached.
- The front jacks will need to be retracted fully using the down arrow for the front.

EQ Smart-Level Bluetooth Operation

- If the face of your keypad indicates that your controller is compatible with a Bluetooth device, download EQ Smart-Level in the Android or Apple App Store. When downloading the app, make sure your Bluetooth setting is turned on or the app will not connect to your coach. Once the app is downloaded please follow the instructions to level your coach.
- If your keypad does not indicate compatibility, your Bluetooth connectivity may be through your multiplex system.
- The operation of the system from a smart phone is the same as from the control panel with the exception that you cannot perform the orientation setting or null programming from the Bluetooth.



Note: The All Retract button will only retract the rear (and center jacks on a 6 point) on a trailer system. Use the manual arrow for the front jacks once the trailer is connected to the tow vehicle.

PANEL INDICATOR LED'S

During typical operation, the LED's on the bottom left hand corner of the keypad should NOT be illuminated. The only LED that should light is the OPERATING LED, which should flash during operation.

Power LED	ON Red when Power is ON OFF when power is OFF SLEEP MODE Flashes every 1 second
Jack LED	ON Red when Jack(s) are deployed OFF when Jack(s) are stowed
Operating LED	ON Red w/Auto Level or All Retract OFF when keypad is idle or sleeping
Low Volatage LED	ON Red when voltage is below 10.5 VDC OFF when voltage is above 10.5 VDC
Engage Park Brake LED	ON Red when park brake is not set OFF when park brake is set
Ignition On LED	ON Red when ignition is in the ON position OFF when igation is off
Excess Slope LED	ON Red following an Auto Level attempt if system cannot overcome slope OFF when slope is not excessive

If the LOW VOLTAGE, or EXCESS SLOPE LED's illuminate, you have an error condition that must be corrected prior to operating the jacks.

Note: After an Auto Level process the operation light should turn off and the Excess Slope light should be off. This indicates that the system has finished leveling and is within the .5-degree (approx. 7/16 inch over 4 feet) front to rear and side to side leveling specification.

If the Excess Slope light is on, then the system was not able to complete the process within the .5-degree specification. There are several possibilities to include but not limited to Low Voltage, jack(s) running out of travel or system/component failure.

MANUAL OVERRIDE OPERATION

The leveling system is equipped with the ability to override in the event of system failure. This will allow the jacks to be retracted so that the vehicle can be taken to a service/repair facility. The most common cause of system failure is weak/dead batteries, so it is best that the batteries be charged so that the jacks can be retracted in the normal manner.

- If the below described override procedure (there are different procedures for different pump assemblies) is needed on a trailer, it is recommended that the rear jacks be fully retracted first.
- When the tow vehicle is properly placed for coupling the front jacks can be lowered. This is performed by identifying which valves are for the rear and which ones are for the front. See the drawing for this.
- Then using the described 1/8" Allen wrench to open/operate the rear jacks then the front.

**Note: The two valves closest to the reservoir are for the front jacks.
For further help call EQ Systems for assistance.**

Manual Override for Bi-Rotational Pump # 2542KS

Your hydraulic pump is equipped with a bi-rotational motor.

- You will use a 2000 r.p.m. drill and a 7/16" socket or 1/4" Allen Driver.
- Care must be taken to ensure neither the drill nor the socket contact any wires or hydraulic hoses while in use.

To Operate Your Jack(s) Using the Manual Override (with Bi-Rotational Motor)

- The individual cartridge valves are clustered together on the side of the pump manifold. They are labeled 1 thru 4. Locate the screws on the appropriate cartridge valve(s). Using a 1/8" Allen wrench, turn the screw(s) clockwise until seated in.
- The pump may or may not have a DV-2 valve on the opposite side of the manifold. If it does turn the 1/8" Allen screw clockwise until seated in.

There are 2 motor types.

- Some motors have a black plastic plug in the end of the motor. Remove this plug by prying with a small screwdriver.
 - Some motors have a foil sticker on the end, remove this sticker.
-
- Place the drill with the 7/16" socket or 1/4" Allen on the manual override shaft located at the end of the motor.
 - To retract your jack(s) run the drill in the counter-clockwise direction. To extend your jack(s), run the drill in the clockwise direction.

See drawings on next page.

Following manual override operation, failure to return all valves to normal position may result in one or more jacks drifting/traveling down from their retracted (stowed) position. For cartridge valves, rotate the center screw fully counter-clockwise.

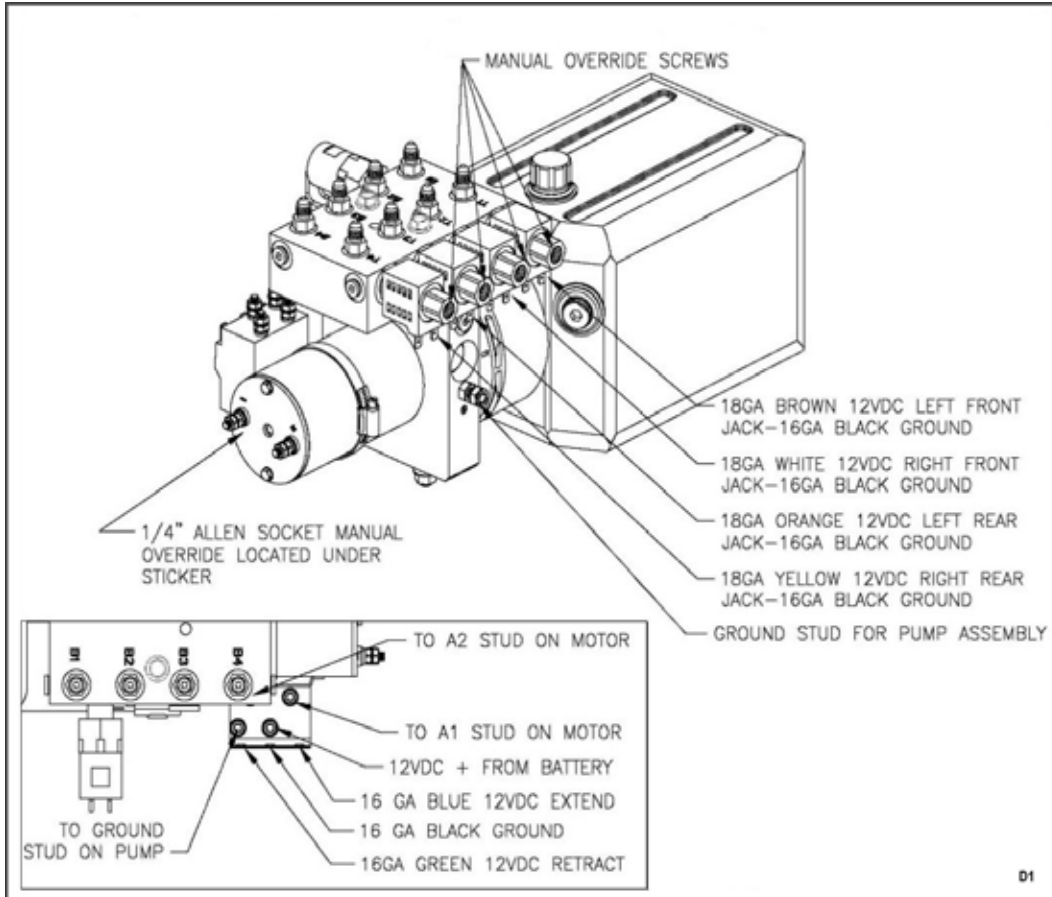



(800) 846-9659

EQ SYSTEMS TORQUE SPECIFICATIONS

July 2024

The following list are items that the installer would encounter during the normal installation. The values listed are for EQ supplied fasteners and components. For other fasteners not listed follow EQ Systems specific installation manual instructions and or fastener industry/supplier specifications for fastener size, thread and grade. Generally, EQ systems use GR 5 specifications.

Adaptor Fittings At Manifold And Jack Cylinders

See installation instructions for proper installation/tightening of 90-degree fittings.

15-18 LB. FT.

Hose Fittings To Adaptor Fittings At Manifold And Cylinders

12 – 15 LB. FT.

Jack Cylinder To Bracket

75 LB. FT.

Box Bolt (front Jack mount sprinter chassis)

140 LB. FT

Jack Mount Clamp Bracket Bolts

50 LB. Ft.

Cross Tie U-Bolts

18 LB. FT

Cross Tie Joint Bolt & Nut

7 LB. FT.

Pump Mount Stud/Bolt 3/8-16 Stud With Hex Nut (9/16-inch wrench)

20 LB. FT.

Electrical Connections

Motor Solenoid (contactor, reversing polarity type) Wire Terminals/Battery Positive Connection 6 MM Brass Stud (10 MM wrench)

32 to 34 LB. IN.

Motor Solenoid, Uni Directional Type

Battery Connection Terminal Stud. Battery Positive Connection.

5/16-18 Brass Stud (1/2 or 9/16 wrench) or M8-1.25 (13 mm wrench)

6-7 LB. FT.

Pump Ground Stud 5/16-18 Stud With Hex Nut (1/2-inch wrench)
15-18 LB. FT.

Pump/Manifold Replacement Parts
Manifold To Lower Assembly Studs/Nuts 5/16-18 (1/2-inch wrench/socket)
12 to 20 LB. FT.

Manifold Adaptor Fittings And Plugs, Including Purge Coupler Nipples
15-18 lb. FT.

Pressure Switch
12 - 15 LB. Ft.

Manifold Valve
12 - 15 LB. FT.

Manifold Valve Coil Nut
4-6 LB. FT.

Reservoir Screws 5 mm (8 mm wrench)
4.5 LB. FT.

ELECTRICAL

Motor Solenoid/Contactors #2994
Motor Solenoid (contactor, reversing polarity type) Wire Terminals/Battery
Positive And Ground Connection And Contactor To Motor Lead Studs
6 MM Brass Stud (10 MM wrench)
32 to 34 LB. IN.

Motor Solenoid, Uni Directional Type. # 1444 and # 4252
Battery Connection Terminal Stud. Battery Positive Connection.
5/16-18 Brass Stud (1/2 or 9/16 wrench) or M8-1.25 (13 mm wrench)
6-7 LB. FT.

Primary Stud Terminal SS # 10-32 (3/8-inch wrench)
25-30 LB. In.

Motor Attachment Screws 5 mm (8 mm wrench)
4.5 LB. FT.

Motor Terminal Stud/Nut (10 MM wrench)
32 -34 LB. IN.



MOTORHOME & FIFTH WHEEL WARRANTY

EQ Systems (Equalizer Systems) Limited Warranty Policy May 2022

1. EQ Systems (Equalizer Systems) warrants slide out and leveling system components for a period of **one year** from the date of original sale of the vehicle. This warranty covers defects in material and workmanship only. EQ Systems (Equalizer Systems) is not liable for any damage due to abuse, neglect, misuse, negligence, misapplication, error of operation, accidental or purposeful damage or damage due to an "act of God" such as, wind or rain damage, flood, lightning, or other natural occurrence of the like. EQ Systems (Equalizer Systems) limited warranty is applicable to the EQ Systems (Equalizer Systems) components only and does not apply to the vehicle, apparatus, or property to which it is attached. Warranty parts will be shipped at no charge if the repair is authorized by an EQ Systems (Equalizer Systems) representative. Purchased components used in authorized warranty repairs will be reimbursed at the original purchase price.
2. Labor and freight expenses due to warrantable parts defects or workmanship will be reimbursed for a period of **one year** from the date of original sale of the vehicle. Freight expenses will either be prepaid by EQ Systems (Equalizer Systems) or reimbursed at the UPS Ground rate only. Any additional shipping charges or requirements are the obligation of the vehicle owner or service center performing the warranty repair. The owner or service center's obligation may include overseas shipping charges, border fees, brokerage fees and any other additional fee of the like.
3. Warranty labor will be reimbursed only for claims that have prior written or verbal authorization from an EQ Systems (Equalizer Systems) representative. Warranty labor compensation is required to correspond with the "OEM Warranty & Procedure Manual" published by EQ Systems (Equalizer Systems). Any warranty repair not listed on this guideline will require prior authorization from an EQ Systems (Equalizer Systems) representative. A reasonable time allowance will be determined by the EQ Systems (Equalizer Systems) representative. Any warranty repair that is not listed on this guideline that is performed without prior authorization will be denied without exception. Time associated with learning about the repair or excessive diagnostic and installation time will not be reimbursed. Warranty labor will be reimbursed at the authorized service center's published shop rate if the rate is reasonable for that region. Overtime labor will not be reimbursed without exception.
4. Labor, parts, and freight credit (if applicable) will be sent when the parts are tested, and the warranty claim is validated. Returned parts that are found to be in normal operating condition are not warrantable and will be charged to the owner or service center. EQ Systems (Equalizer Systems) reserves the right to charge back the service center for labor claim payments previously submitted if the installation of the warranted part is found to be inadequate at a later date.
5. Claims will be denied if the date submitted is greater than 120 days from the repair date.
6. Prior authorization is required before parts may be sent back to EQ Systems (Equalizer Systems). A Return Authorization Number is required for items to be accepted.
7. Complete systems are not warranted unless authorized by an EQ Systems (Equalizer Systems) representative. There are absolutely no exceptions to this clause.
8. Warranty coverage for parts or systems sold by non-authorized resellers (such as live or internet auctions) will be at the discretion of EQ Systems (Equalizer Systems).
9. EQ Systems (Equalizer Systems) is not liable for loss of time, manufacturing costs, labor, material, loss of profits, direct or indirect damages incurred by the vehicle manufacturer.
10. Excessive warranty labor resulting from inadequate access to the EQ Systems (Equalizer Systems) product will not be reimbursed.
11. EQ Systems (Equalizer Systems) will not pay a markup on warranty parts unless required by law.
12. Travel expenses, hotel, telephone, fuel, or any other expenses of the like are not covered under warranty.

Replacement Parts:

1. Replacement parts are warranted under the same guidelines listed above for the remainder of the original warranty or 90 days, whichever is longer. Proof of warranty repair date and original vehicle purchase date are required. No additional warranties, expressed or implied, are authorized by EQ Systems (Equalizer Systems)

This warranty voids all previous issues.

**Questions concerning this warranty should be directed to:
EQ Systems (Equalizer Systems) | 19300 Grange Street, Cassopolis, MI, 49031
574-264-3437 | (800) 846-9659**

To activate your warranty, please visit our website at www.eqsystems.us/activate-warranty/

Hose and fitting connections for 6 leg trailer leveling systems

PARTS LIST					
ITEM	PART#	DESCRIPTION	QUAN	COLOR CODE	LOCATION
1	1262	FITTING-UNION TEE	4	-	BETWEEN REAR JACKS
2		HOSE-	1	BROWN SOLID	PUMP PORT T1 TO TOP OF LF JACK
3		HOSE-	1	BROWN STRIPE	PUMP PORT B1 TO BOTTOM OF LF JACK
4		HOSE-	1	YELLOW SOLID (2 STICKERS)	TOP OF RM JACK TO TEE
5		HOSE-	1	YELLOW SOLID (2 STICKERS)	TOP OF RR JACK TO TEE
6		HOSE-	1	YELLOW STRIPE (2 STICKERS)	BOTTOM OF RM JACK TO TEE
7		HOSE-	1	YELLOW STRIPE (2 STICKERS)	BOTTOM OF RR JACK TO TEE
8		HOSE-	1	ORANGE SOLID (2 STICKERS)	TOP OF LM JACK TO TEE
9		HOSE-	1	ORANGE SOLID (2 STICKERS)	TOP OF LR JACK TO TEE
10		HOSE-	1	ORANGE STRIPE (2 STICKERS)	BOTTOM OF LM JACK TO TEE
11		HOSE-	1	ORANGE STRIPE (2 STICKERS)	BOTTOM OF RR JACK TO TEE
12		HOSE-	1	WHITE SOLID	PUMP PORT T2 TO TOP OF RF JACK
13		HOSE-	1	WHITE STRIPE	PUMP PORT B2 TO BOTTOM OF RF JACK
14		HOSE-	1	ORANGE SOLID	PUMP PORT T3 TO TEE
15		HOSE-	1	ORANGE STRIPE	PUMP PORT B3 TO TEE
16		HOSE-	1	YELLOW STRIPE	PUMP PORT B4 TO TEE
17		HOSE-	1	YELLOW SOLID	PUMP PORT T4 TO TEE

