



# **EL-PAC 1 & 2**

## **Installation/Operation/Warranty Guide**

Effective January 2011

**EQ008R5**

**WARNING: READ ENTIRE INSTRUCTIONS AND ALL PRECAUTIONS PRIOR TO INSTALLING, USING OR TROUBLESHOOTING THIS EQUIPMENT.**

**CONTENTS**

**General Notes for EI Pac 1 & 2 ..... 3**

**Installation of EI Pac 1 on Single Speed Bulldog, Fulton, and Ram Jacks ..... 4**

**Installation of EI Pac 1 on Single Speed Fulton Jacks ..... 5**

**Installation of EI Pac1 on Two Speed Bulldog Jacks with 4” x 4” Gear Reduction Box ..... 6 & 7**

**Installation of EI Pac 2 on Binkley Two Speed Jacks Driver’s Side..... 8 & 9**

**Installation of EI Pac 2 on Binkley Two Speed Jacks Passenger’s Side..... 10**

**Power Supply and Switchgear Connections for EI Pac 1 & 2 .....11 & 12**

**Basic Troubleshooting ..... 13**

**Parts List..... 13**

# GENERAL NOTES FOR EL PAC 1 AND EL PAC 2

## ELECTRIC LIFTING SYSTEMS

The recommended maximum floor lengths are guidelines. However, the installer must use judgment based on each individual trailer. Items to consider: aluminum or steel construction; width of trailer; length of living quarter; materials used in the living quarter (hardwood floors, solid surface countertops, etc.); water and holding tanks; tool boxes; tack; etc. If the trailer is on the edge of our length recommendation below, please weigh the trailer. The tongue weight of the trailer must be less than the maximum lift capacity of the product.

Questions? Call EQ Systems at (800) 846 9659 for technical assistance.

The **EI Pac 1** gearbox has a specific gear ratio and a maximum lifting capacity of 5,000 lbs. It is recommended that the length of the trailer should be not greater than 28 feet of floor length.

The **EI Pac 1** must be installed on a Bulldog (Cequent) Single Speed jackleg, Fulton Single Speed jackleg (this leg should have a stamp or decal that says “gear driven adaptable”), Ram Single Speed jackleg, or 2-Speed Bulldog jacklegs. The EI Pac1 is not compatible with any other jackleg.

---

The **EI Pac 2** gearbox has a specific gear ratio and a maximum lifting capacity of 6,500 lbs. It is recommended that the length of the trailer should be no greater than 32 feet of floor length.

The **EI Pac 2** must be installed on Binkley 2-speed jacklegs. **The EI Pac 2 is not approved for use with any other jackleg.**

### **AVOID HEADACHES**

**You must determine the manufacturer of the jackleg installed on your trailer prior to installing the EI Pac to ensure it is the correct model for your application. Please note that decals or stickers alone are often insufficient to determine the OEM of your jacklegs(s).**

# INSTALLATION OF EL PAC 1

## (SINGLE SPEED BULLDOG, FULTON, AND RAM JACKS)

The El Pac 1 must be installed on the Bulldog Single Speed jackleg, Fulton Single Speed jackleg, or the Ram Single Speed jackleg (the Fulton and Ram legs should have a stamp or decal that says “gear driven adaptable”). Any other single speed jackleg is NOT compatible with the El Pac 1.

Once again, the El Pac 1 is designed to mount on either side of the jack leg; however, the preferred mounting would be on the passenger side of the jack leg if space permits. This enables you to leave the factory crank rod in place as a manual back-up. When using the manual crank as a back up, it is recommended to remove the wires from the gear box prior to hand cranking. This will allow easier cranking of the jack. If mounting on the driver’s side of the trailer, the factory crank and handle attaches to the El Pac 1 override output shaft. When attaching your factory crank shaft to the override output shaft, use the supplied nylon bushing (part # 1961E). When properly mounted on the passenger side of the jack leg, this unit has a maximum lifting capacity of 5000 lbs of jack weight.

**Warning: Remove the factory crank handle from the end of the crank rod. Damage may occur to the trailer or persons if the handle is left in place.**

## INSTALLATION OF EL PAC 1 ON BULLDOG AND RAM

1. Decide which side of the jack leg the El Pac 1 will mount. This unit requires 7” of width clearance from the jack leg.
2. Cut off the jack shaft so that 1 1/8” of the shaft remains on the jack leg. Measure this from the outer edge of the bushing/boss.
3. Attach the El Pac 1 to the bracket using the (4) supplied 1/4” X 3/4” bolts and lock washer. Slide the El Pac 1 over jack shaft.
4. Ensuring that the gear box is straight and level with the jack shaft, securely weld the El Pac 1 bracket in place on the front of the jackleg (as shown in picture on page 3).
5. Drill a hole through the jack shaft using the output shaft of the El Pac 1 as a guide. Use the supplied 5/16” x 2” bolt and nylock nut to secure the output shaft to the jack shaft.
6. Mount the switchgear in desired location.
7. Refer to the Power Supply and Switchgear installation instructions.

## INSTALLATION OF EL PAC 1 ON FULTON

Installation of the El Pac 1 on a Fulton jack is done the same way as the Bulldog and Ram jacks with one exception. The Fulton jack has a smaller shaft than the Bulldog and Ram jacks. To take care of this, you use the supplied nylon bushing (part # 1961E) around the shaft prior to sliding the El Pac 1 in place.

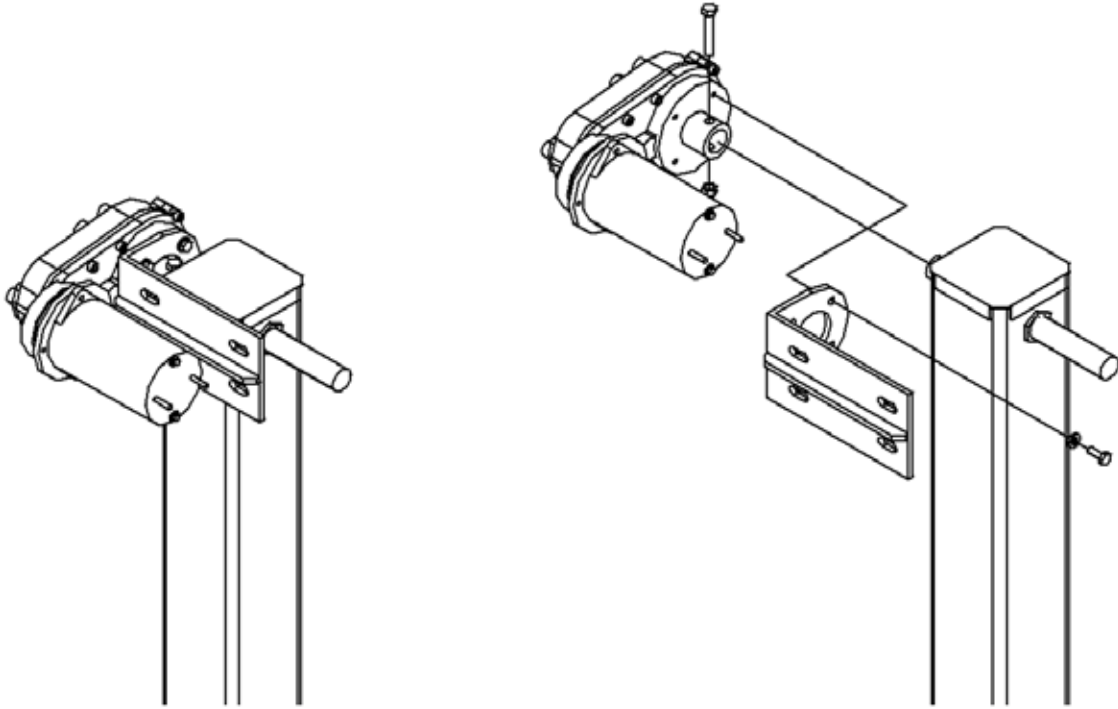

**Dual Leg Application-** The El Pac 1 must be installed on the passenger side of the passenger side jack leg in a dual leg application. When properly mounted, this unit has a maximum lifting capacity of 5000 lbs. of combined jack weight. Due to the additional linkage required to add a second jack, and the possible misalignment of the jacks, you could experience a loss of lifting capacity in the 10% range.

# INSTALLATION OF EL PAC 1

## (TWO SPEED BULLDOG JACKS WITH 4" X 4" GEAR REDUCTION BOX)

**Single Leg Application-**The El Pac 1 must be installed on the passenger side of a single Bulldog two-speed jack with the 4" x 4" gear reduction box. This enables utilization of the existing crank shaft and handle as a manual override. When using the manual crank as a back up, it is recommended to remove the wires from the gear box prior to hand cranking. This will allow easier cranking of the jack. The Bulldog two-speed jack leg must be in the high (hard to turn) gear prior to installation of the El Pac 1. When properly mounted, this unit has maximum lifting capacity of 5000 lbs. of jack weight.

**Dual Leg Application-**The El Pac 1 must be installed on the passenger side of the passenger side jack leg with Bulldog two-speed jacks with the 4" x 4" gear reduction box in a dual leg application. When properly mounted, this unit has a maximum lifting capacity of 5000 lbs. of combined jack weight. Due to the additional linkage required to add a second jack, and the possible misalignment of the jacks, you could experience a loss of lifting capacity in the 10% range.

**Warning: Remove the factory crank handle from the end of the crank rod. Damage may occur to the trailer or persons if the handle is left in place.**

**Failure to follow the above directives will void your warranty.**

## INSTALLATION

**Again, you must leave the jack leg in the high (hard to turn) gear. Do not utilize the first speed. Failure to have the jack leg in the high gear will void warranty.**

1. The El Pac 1 must be installed on the passenger side of the Bulldog two-speed jack with the 4" x 4" gear reduction box. See the drawings on page 5. This unit requires 6" of width clearance from the jack leg.
2. Cut jack shaft (if needed) so that 1 1/8" of the shaft remains from the end of the shaft to the jack body.
3. Attach the El Pac 1 to the bracket using the (4) supplied 1/4" x 3/4" bolts and lock washers.
4. Slide the El Pac 1 gearbox over the shaft. Align the bracket correctly (square to the jackleg and centered on the shaft).
5. Securely weld the bracket onto the front of the jack to hold the bracket in place.
6. Drill a hole through the jack shaft using the output shaft of the El Pac 1 as a guide. Use the supplied 5/16" x 2" bolt and nylock nut to secure the output shaft to the jack shaft.
7. Mount switchgear in the desired location.
8. Refer to the Power Supply and Switchgear installation instructions.

**Two-Speed Bulldog Jacks with 4" x 4" Gear Reduction Box**

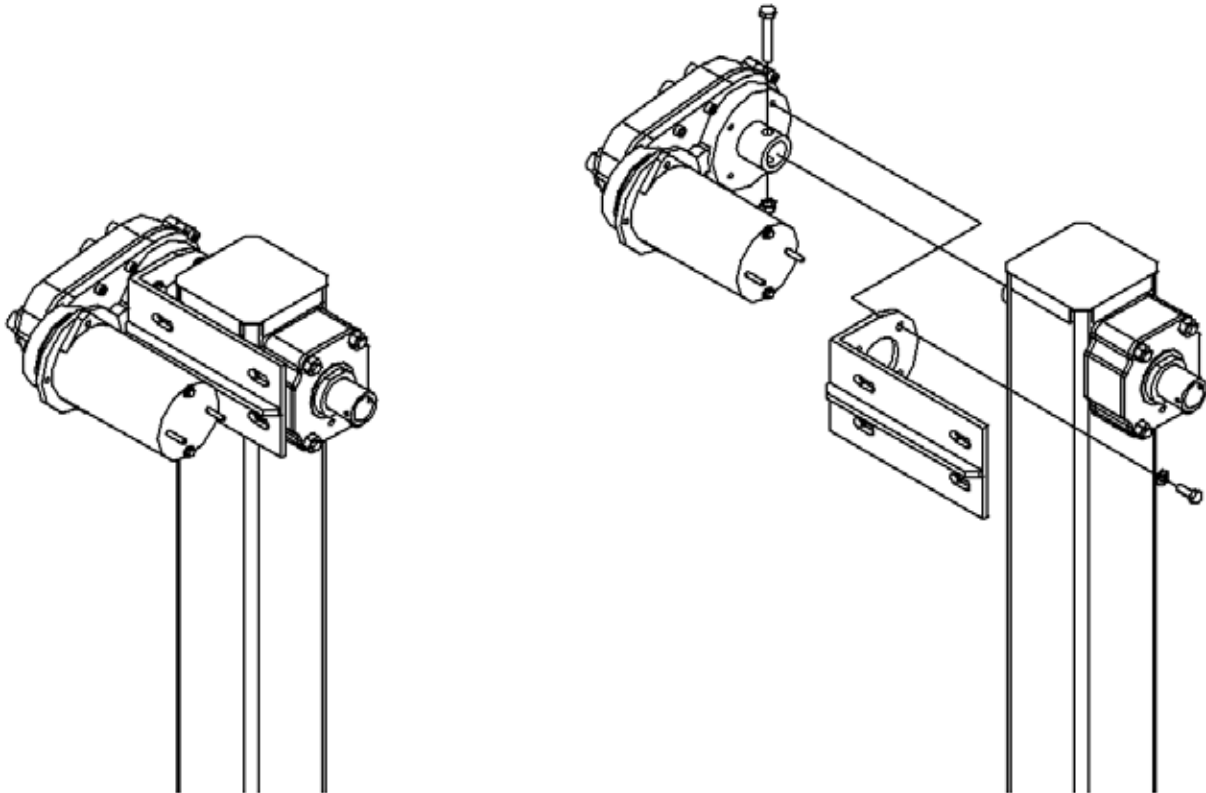



## INSTALLATION OF EL PAC 2 (BINKLEY TWO-SPEED JACKS)

The El Pac 2 is designed to mount on either side of the Binkley 2-speed jack leg. The suggested mounting style is on the driver's side of the existing jack leg. This will allow the factory crank and handle to attach to the El Pac 2 override output shaft. When using the manual crank as a back up, it is recommended to remove the wires from the gear box prior to hand cranking. This will allow easier cranking of the jack. When attaching your factory crank shaft to the override out put shaft, use the supplied bushing (part # 1961E). The El Pac 2 has a maximum lifting capacity of 6,500 lbs. of front jack weight. In 2011 the Binkley jack gear box was changed by the manufacturer. The older jacks are identified by a 1 ½" diameter x 1" long collar on the gear box around the input shaft. The newer version does not have this collar. The installation is slightly different between the two versions. Please look at the illustrations for each version to determine which you have.

**Warning: Remove the factory crank handle from the end of the crank rod. Damage may occur to the trailer or persons if the handle is left in place.**

## INSTALLATION ON DRIVER'S SIDE OF JACK LEG (OLDER STYLE BINKLEY)

1. Decide which side of the jack leg the El Pac 2 will mount. This unit requires 7" of width clearance from the Binkley gearbox for mounting.
2. Pull jack input shaft out into low (easy to turn) gear. Cut jack input shaft (if needed) so that 1 1/8" of the shaft remains.
3. Slide the mounting bracket over the shaft boss and tap into place. Secure the setscrews. It may be necessary to tack weld the bracket in place to keep the bracket from rotating on the Binkley gear box during operation.
4. Slide the El Pac 2 gearbox onto the shaft.
5. Attach the El Pac 2 to the bracket using the (4) supplied ¼" x ¾" bolts and lock washers.
6. Drill a hole through the jack shaft using the output shaft of the El Pac 2 as a guide. Use the supplied 5/16" x 2" bolt and nylock nut to secure the output shaft to the jack shaft.
7. Mount Switchgear in desired location.
8. Refer to the Power Supply and Switchgear installation instructions.



**Older Binkley Two-Speed Jacks-Driver's side installation**

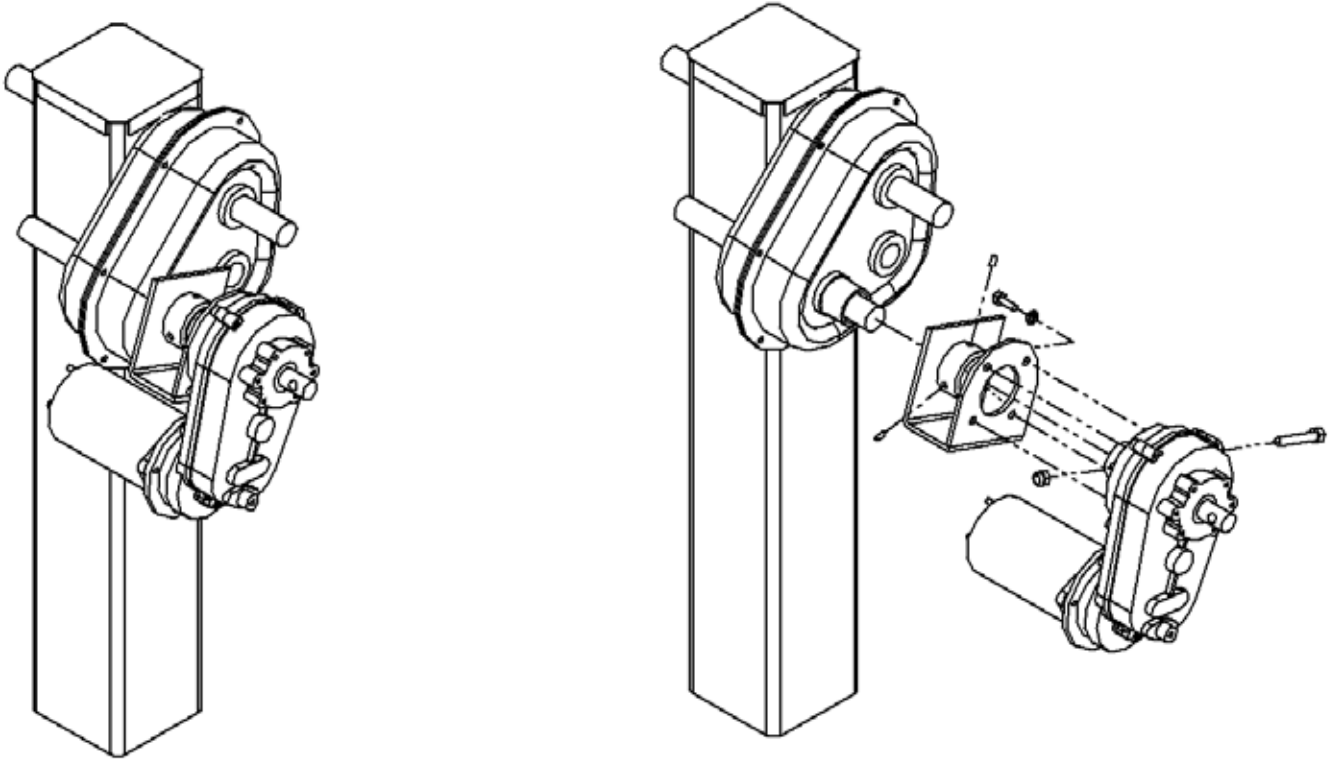

# INSTALLATION ON PASSENGER'S SIDE OF JACK LEG

## (BINKLEY TWO-SPEED JACKS)

1. Again, the suggested (and preferred) mounting style is on the driver's side of the existing jack leg. However, it may be necessary to mount your El Pac 2 on the passenger side of your jack leg due to the space limitations. There must be 2" of shaft extending past the jack leg.
2. Pull crank rod out into low (easy to turn) gear. Attach the El Pac 2 to the bracket using the (4) supplied  $\frac{1}{4}$ " X  $\frac{3}{4}$ " bolts and lock washers...
3. Slide the El Pac 2 gearbox onto the shaft with the mounting bracket and slide the bracket flush against the Binkley jack leg.
4. Ensure the gearbox and bracket are straight. Securely weld the bracket to the leg.
5. Drill a hole through the jack shaft using the output shaft of the El Pac 2 as a guide. Use the supplied  $\frac{5}{16}$ " x 2" bolt and nylock nut to secure the output shaft to the jack shaft.

### **Binkley Two-Speed Jacks-Passenger side installation**

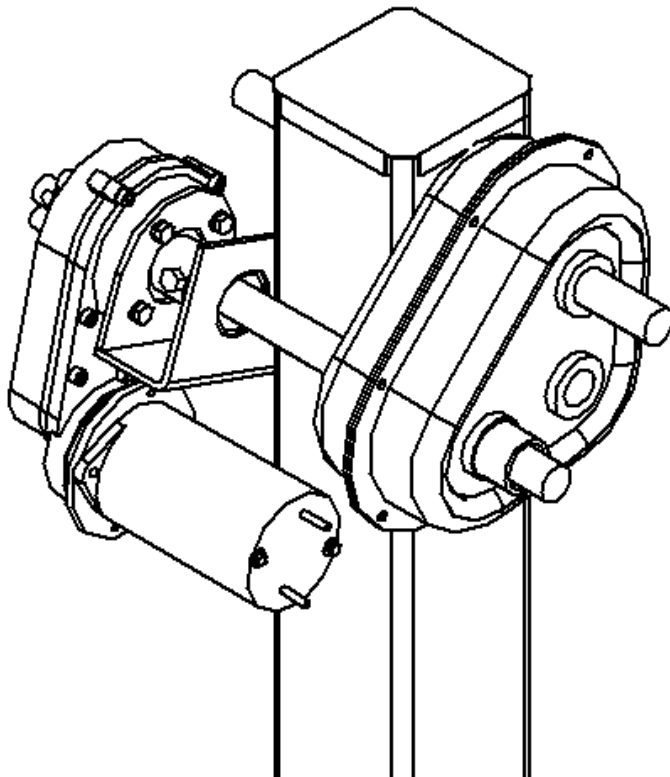

# POWER SUPPLY AND SWITCHGEAR

## CONNECTIONS FOR EL PAC 1 & 2

**Make the connection of the 12V negative cable to the battery the very last connection. Check all other connections and have the switchgear mounted and connected to the El Pac prior to applying power.**

The El Pac 2 is designed to mount on either side of the Binkley 2-speed jack leg. The suggested mounting style is on the driver's side of the existing jack leg. This will allow the factory crank and handle to attach to the El Pac 2 override output shaft. When using the manual crank as a back up, it is recommended to remove the wires from the gear box prior to hand cranking. This will allow easier cranking of the jack. When attaching your factory crank shaft to the override out put shaft, use the supplied bushing (part # 1961E). The El Pac 2 has a maximum lifting capacity of 6,500 lbs. of front jack weight. In 2011 the Binkley jack gear box was changed by the manufacturer. The older jacks are identified by a 1 ½" diameter x 1" long collar on the gear box around the input shaft. The newer version does not have this collar. The installation is slightly different between the two versions. Please look at the illustrations for each version to determine which you have.

**Warning: Remove the factory crank handle from the end of the crank rod. Damage may occur to the trailer or persons if the handle is left in place.**

**Your El Pac system comes with an 80-ampere auto-reset circuit breaker (2 ea. 40 ampere breakers in parallel configuration). Do not install other fuses or circuit breakers.**

1. Mount the switchgear in the desired location, being aware of the provided cable lengths. Mount the switch gear in a location that provides some protection from the elements. The switchgear box is weather-resistant, not weather-proof.
2. Route the two White #6 AWG wires from the switchgear to the El Pac gearbox motor. Use the supplied plastic split loom to protect the wires. Cut both wires to length and install the supplied crimp ring terminal.
3. Attach one White #6 AWG wire to the A2+ and the other to the A1- posts on the motor. Note: The switch may appear to operate backwards, depending on which side of the OEM jack leg your El Pac is mounted and which way the two white wires are connected to the motor. If this is the case, then reverse the two white wires at the motor.

4. Route the Red and Black #6 AWG wire from the switchgear to the battery box. Use the supplied plastic split loom to protect the wires. Note: If the battery is located beyond the front bulkhead of the trailer, #4 AWG wires may be required to provide enough current for your EI Pac to operate properly. Cut the black wire (and loom) to length and install the supplied crimp ring terminal. Do not connect to the battery at this time.
5. Attach the Red #6 AWG wire from the switchgear to the 'AUX' post on the breaker assembly using the supplied crimp ring terminal. This 'AUX' post will have two nuts present and is diagonal from the +12 volt battery pigtail. Install the crimp ring and use first nut as a jamb nut to hold the wire securely to the assembly.
6. Affix the 80-ampere breaker assembly to the battery box or other suitable location. Secure all wire looms to the trailer. Be aware of heat and pinch points.
7. Attach the Red #6 AWG pigtail from the 'BAT' post on the breaker assembly to the +12 volt terminal on the battery.
8. Finally Attach the Black #6 AWG wire to the -12 volt terminal on the battery.

### Rotary Switch Wiring for EI Pac

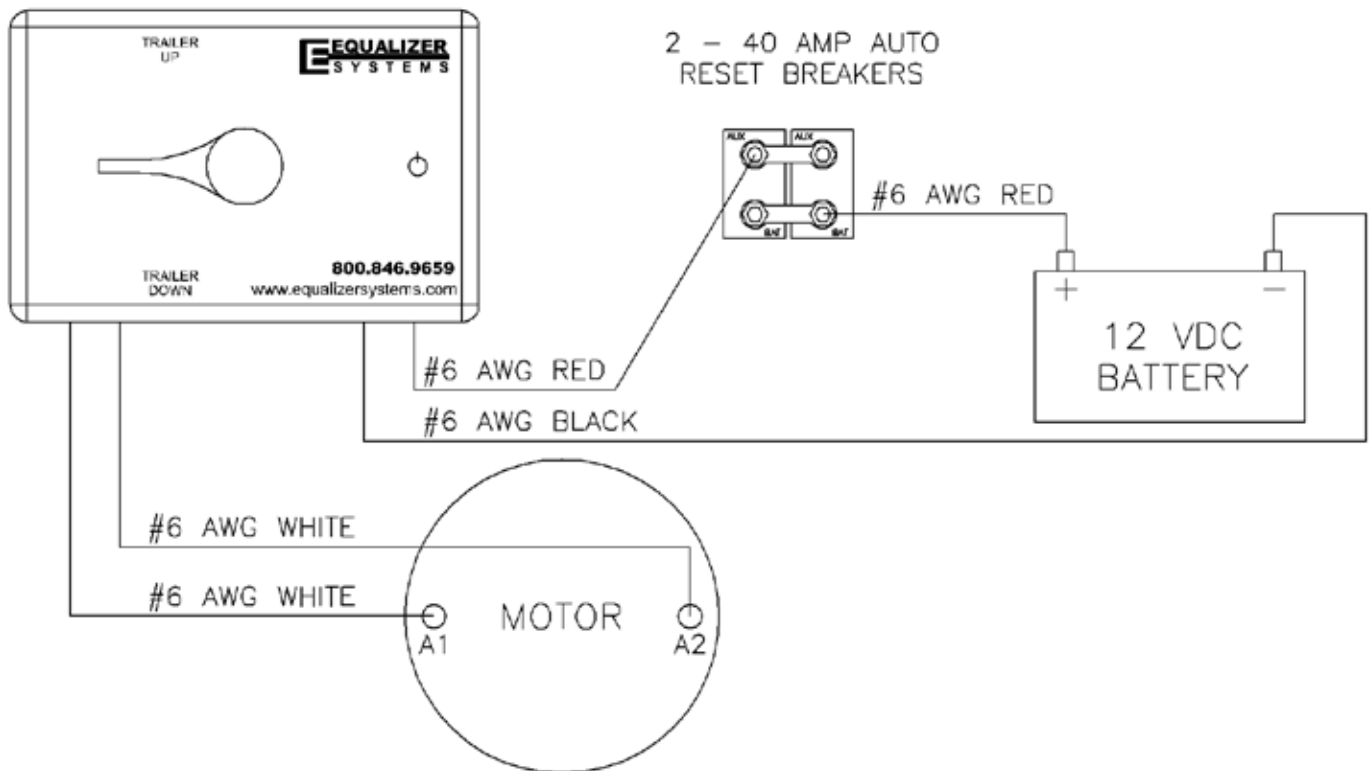

# TROUBLESHOOTING

## **“When I run the motor, it stops or cuts out”**

- Low battery voltage. Charge your batteries.
- System may be over capacity and/or tripping the circuit breaker connected to switchgear.

## **“The motor stalls, or runs but is not moving the jack”**

- The unit is overloaded. The load may exceed the maximum lifting capacity. Check the weight of the trailer on the jack(s).
- Two speed jack in improper gear.
- The clutch in the El Pac 1 may be set too low. Call EQ at (800) 846-9659 for assistance.

# PARTS LIST

8148B	El Pac 1-Complete System
8165B	El Pac 2-Complete System
6677	El Pac Switch and Harness Assembly-Complete Assembly
6585	Breaker Supply Harness
2708	El Pac 1 Motor/Gearbox
2550	El Pac 2 Motor/Gearbox

### **Part #6677 Includes:**

2544	Switch Gear Box-Housing Only
7779	Rotary Switch

### **Other El Pac 1 & 2 Parts:**

2125	40 Amp Thermal Circuit Breaker
2372	El Pac 2B Bracket
2530	El Pac 1B Bracket
1961E	Nylon Override Output Shaft Bushing