



TJ SERIES

Installation/Operation/Warranty Guide

Effective January 2012

EQ006R6



(800) 846-9659
EQSystems.us

TJ SERIES

Hydraulic Trailer Tongue Jack System - 8065M

INSTALLATION

Tools Required for Installation

- Ratchet, sockets and wrench set
- ½ inch Allen wrench (hex key)
- Wire cutters/crimpers
- Electric drill and bits
- Screw gun bit

Additional Parts Needed for Installation

- #6 gauge power wire (to connect battery +12V to the pump motor contactor)
- #6 gauge ground wire (to connect battery ground to pump motor contactor)
- #6 gauge ring terminals
- Wire ties
- Loctite® #242 or equivalent
- Dexron® Automatic Transmission Fluid



SYSTEM MOUNTING

Jack Leg

Remove the existing manual jack from the trailer frame. Be sure to support the trailer weight with appropriate size jack stands.

The TJ style jack is shipped without the foot attached. Slide the jackleg cylinder through the A-frame mounting flange. Secure using the supplied 3/8 inch bolts, flats washers, and locking nuts. If alternate bolts are used, the bolts must be grade 5 minimum.

Jack Foot

Locate the jack foot (part #1389) and the $\frac{3}{4}$ -10 X 1 $\frac{1}{4}$ screw (part #1383).

Attach the foot to the jack legs using the $\frac{3}{4}$ -10 X 1 $\frac{1}{4}$ screw. Use Loctite® #242 or equivalent and tighten securely.

SWITCH HARNESS AND HYDRAULIC LINES

The TJ series jack has been shipped with all necessary switchgear, harnesses and hydraulic lines. These items are specifically engineered to operate your system and should not be altered in any manner. Modification of any factory-supplied item may result in the denial of all warranty claims.

BATTERY CONNECTIONS

(Also see photo and schematic)

Battery Lead (+12volts): Attach a # 6-gauge (minimum) wire between the positive +12 volt terminal on the battery and the plus (+) terminal on the motor contactor; shown in Fig 2. There is a small red wire on this terminal. If circuit protection is required, install an 80 amp (minimum) circuit breaker.

Pump Ground (-12volts): Attach a #6 gauge (minimum) wire between the negative -12 volt terminal on the battery and the negative terminal on the contactor. There is a small black wire on this terminal.

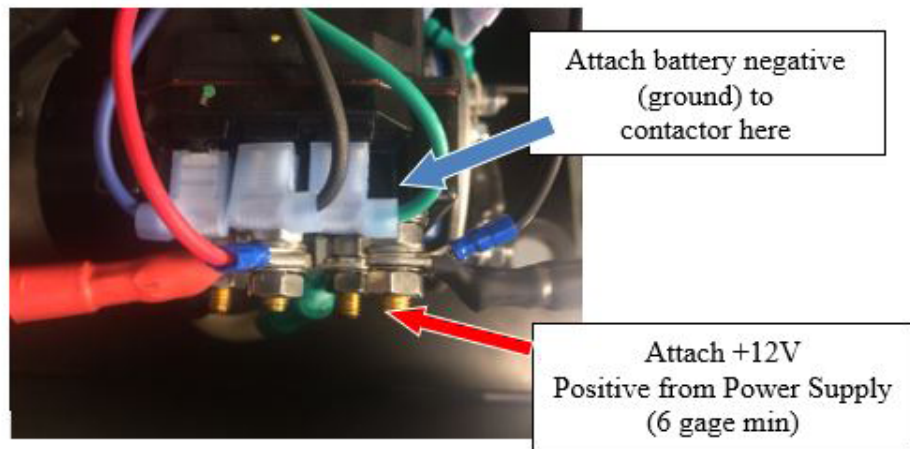

Reversing Contactor Wiring

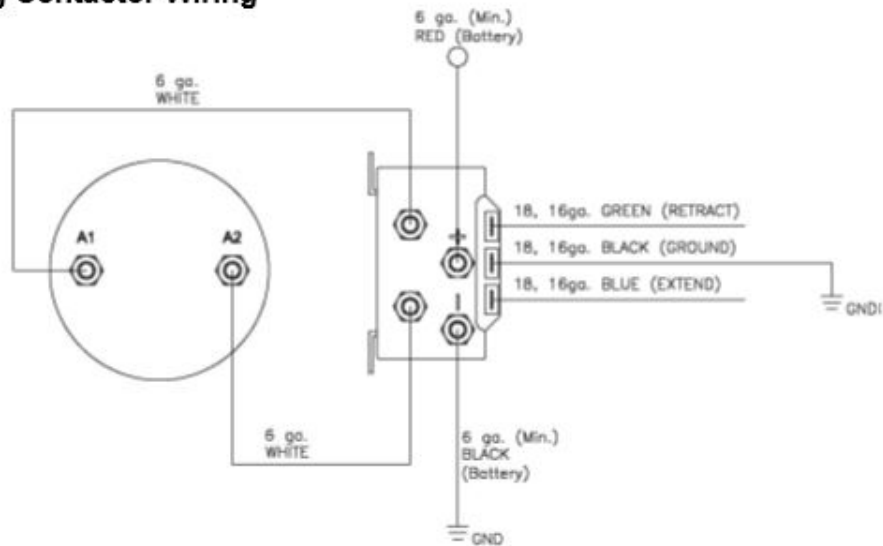

RESERVOIR BREATHER CAP

Remove the shipping plug from the reservoir fill port and discard. Install the supplied breather cap. Failure to install the breather cap will result in erratic jack operation.

RESERVOIR FLUID LEVEL

When the jack is fully retracted, the fluid level in the reservoir should be approximately one inch below the fill cap. If fluid needs to be added, use Dexron automatic transmission fluid (the same as used for a GM automobile).

OPERATION

To raise and lower the jack, simply push and hold the rocker switch in the up or down position. The jack will hold a position by releasing the switch at any time. There is no need to take the weight off the jack when storing the trailer, as the positive check valves in the system will not allow the jack to bleed down.

Warning: With any hydraulic application, holding any position on a cylinder must be done with safety in mind. Failure in the system may cause the leg to retract or extend on its own. When working under or near the trailer, always use jack stands of appropriate rating to support the weight of the trailer.

The keyed switch must be in the off position and the key must be removed when the jack is not in use and/or when the trailer is in transit. If unit is not supplied with a keyed switch, the +12v battery lead must be fed through a power disconnect switch to fully isolate the system during inactivity or travel. The minimum switch rating must be 80 ampere DC.

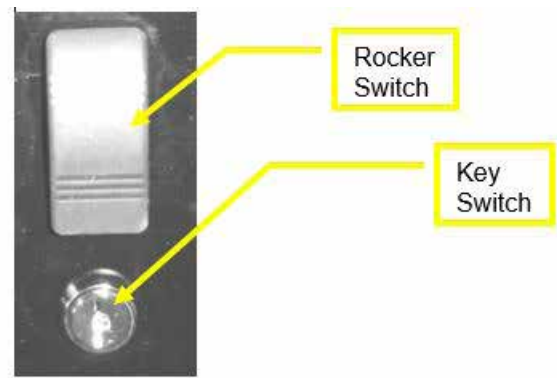

MANUAL OVERRIDE

The TJ series pump has provisions for manual override.

Before you begin this procedure, please read and understand these instructions.

Required Items:

- Reversible Drill- capable of producing a minimum of 2000 r.p.m.
- 6mm(1/4") Hex Key (Allen Wrench) bit or driver.

To override the jack:

Remove the foil seal from the top of the motor. Use a small flat head screwdriver if necessary.

Insert the 6mm (1/4") hex key (Allen) bit on the manual override shaft located at the top of the motor.

To Retract:

Run drill in the **clockwise** direction at 2000 r.p.m. (minimum). The jack will retract.

To Extend:

Run drill in the **counterclockwise** direction at 2000 r.p.m. (minimum). The jack will extend.

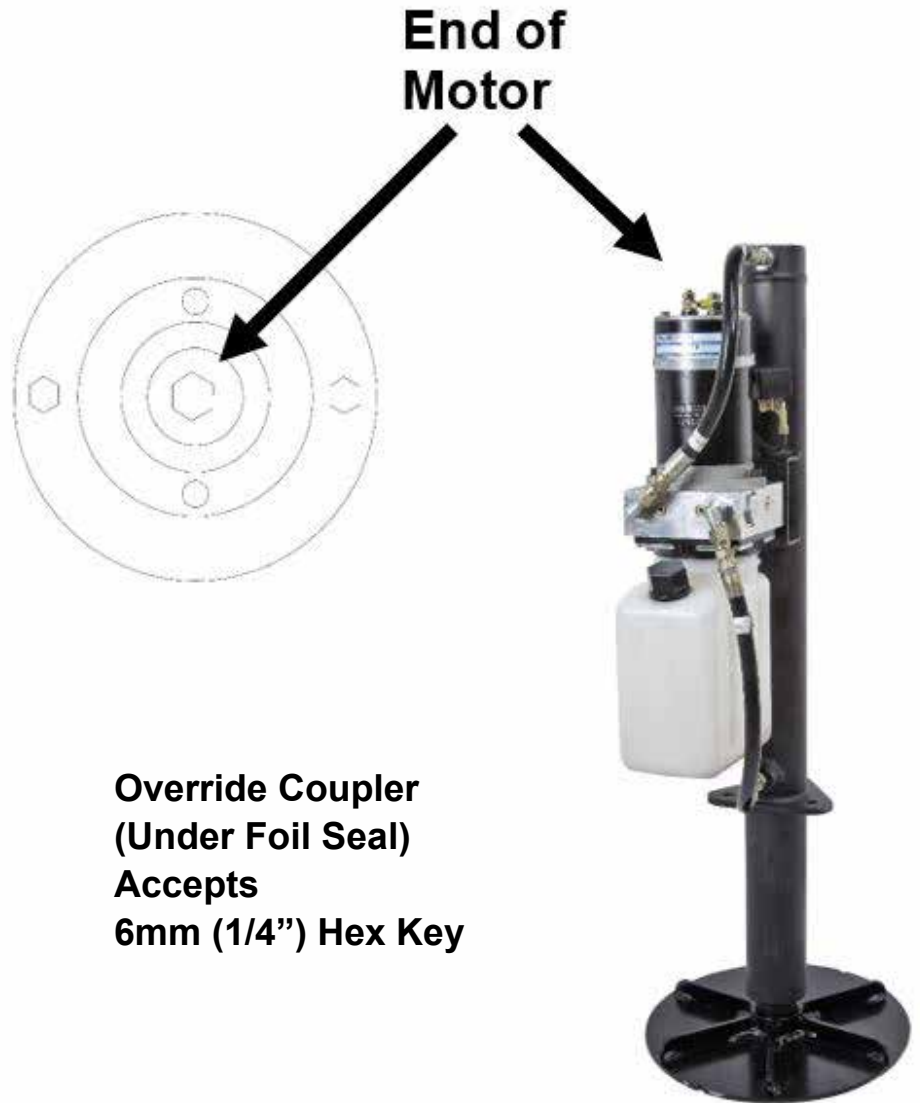

PROBLEM SOLVING

“The jack runs for a few seconds, then stops” The battery is weak or battery capacity is diminished. Charge the battery fully. It may be necessary to “load test” the battery.

“The jack only runs in one direction” Verify appropriate battery voltage. Verify that all wires are attached appropriately. Verify proper function of the switchgear.

“I push the switch and nothing happens” Ensure both positive and negative -12V have adequate connection. Ensure full charge on your battery. The vast majority of calls to the EQ Systems Help Desk are related to low battery voltage. Ensure that the unit is properly grounded to the battery with a minimum # 6-gauge wire. Check all associated wiring.

“The jack is jerky when retracting” This may be caused by air in the system, low fluid level, or incorrect hose installation. To purge leg, add fluid as necessary and run the leg to full extension and retraction at least twice. If problem persists, call EQ Systems for assistance.

Fluid Level: When the jack is fully retracted, the fluid level in the reservoir should be approximately one inch below the fill cap. If fluid needs to be added, use Dexron III automatic transmission fluid (the same as used for a GM automobile).



TRAILER WARRANTY

EQ Systems (Equalizer Systems) Limited Warranty Policy May 2022

1. EQ Systems (Equalizer Systems) warrants slide out and hydraulic jack components for a period of **two year** from the date of original sale of the vehicle. This warranty covers defects in material and workmanship only. EQ Systems (Equalizer Systems) is not liable for any damage due to abuse, neglect, misuse, negligence, misapplication, error of operation, accidental or purposeful damage or damage due to an "act of God" such as, wind or rain damage, flood, lightning, or other natural occurrence of the like. EQ Systems (Equalizer Systems) limited warranty is applicable to the EQ Systems (Equalizer Systems) components only and does not apply to the vehicle, apparatus, or property to which it is attached. Warranty parts will be shipped at no charge if the repair is authorized by an EQ Systems (Equalizer Systems) representative. Purchased components used in authorized warranty repairs will be reimbursed at the original purchase price.
2. Labor and freight expenses due to warrantable parts defects or workmanship will be reimbursed for a period of **one year** from the date of original sale of the vehicle. Freight expenses will either be prepaid by EQ Systems (Equalizer Systems) or reimbursed at the UPS Ground rate only. Any additional shipping charges or requirements are the obligation of the vehicle owner or service center performing the warranty repair. The owner or service center's obligation may include overseas shipping charges, border fees, brokerage fees and any other additional fee of the like.
3. Warranty labor will be reimbursed only for claims that have prior written or verbal authorization from an EQ Systems (Equalizer Systems) representative. Warranty labor compensation is required to correspond with the "OEM Warranty & Procedure Manual" published by EQ Systems (Equalizer Systems). Any warranty repair not listed on this guideline will require prior authorization from an EQ Systems (Equalizer Systems) representative. A reasonable time allowance will be determined by the EQ Systems (Equalizer Systems) representative. Any warranty repair that is not listed on this guideline that is performed without prior authorization will be denied without exception. Time associated with learning about the repair or excessive diagnostic and installation time will not be reimbursed. Warranty labor will be reimbursed at the authorized service center's published shop rate if the rate is reasonable for that region. Overtime labor will not be reimbursed without exception.
4. Labor, parts, and freight credit (if applicable) will be sent when the parts are tested, and the warranty claim is validated. Returned parts that are found to be in normal operating condition are not warrantable and will be charged to the owner or service center. EQ Systems (Equalizer Systems) reserves the right to charge back the service center for labor claim payments previously submitted if the installation of the warranted part is found to be inadequate at a later date.
5. Claims will be denied if the date submitted is greater than 120 days from the repair date.
6. Prior authorization is required before parts may be sent back to EQ Systems (Equalizer Systems). A Return Authorization Number is required for items to be accepted.
7. Complete systems are not warranted unless authorized by an EQ Systems (Equalizer Systems) representative. There are absolutely no exceptions to this clause.
8. Warranty coverage for parts or systems sold by non-authorized resellers (such as live or internet auctions) will be at the discretion of EQ Systems (Equalizer Systems).
9. EQ Systems (Equalizer Systems) is not liable for loss of time, manufacturing costs, labor, material, loss of profits, direct or indirect damages incurred by the vehicle manufacturer.
10. Excessive warranty labor resulting from inadequate access to the EQ Systems (Equalizer Systems) product will not be reimbursed.
11. EQ Systems (Equalizer Systems) will not pay a markup on warranty parts unless required by law.
12. Travel expenses, hotel, telephone, fuel, or any other expenses of the like are not covered under warranty.

Replacement Parts:

1. Replacement parts are warranted under the same guidelines listed above for the remainder of the original warranty or 90 days, whichever is longer. Proof of warranty repair date and original vehicle purchase date are required. No additional warranties, expressed or implied, are authorized by EQ Systems (Equalizer Systems)

This warranty voids all previous issues.

**Questions concerning this warranty should be directed to:
EQ Systems (Equalizer Systems) | 19300 Grange Street, Cassopolis, MI, 49031
574-264-3437 | (800) 846-9659**

To activate your warranty, please visit our website at www.eqsystems.us/activate-warranty/